



Pelicanator

1/2 HP Continuous Feed
Garbage Disposal

Features

- Space Saving Compact Design
- Torque Master Grinding System
- Factory Installed Power Cord with Plug
- Removable Splash Guard
- Well and Septic Safe
- Lifetime Warranty Against Corrosion

Technical Information

- HP: 1/2
- Feed: Continuous
- Volts: 110 Volts
- Frequency: 50/60Hz
- Wattage: 375W
- Amperage: 3.25A
- Motor Speed: 3200 RPM
- Hopper Capacity: 29oz
- Balance Level: G 0.4
- Turntable/Grind Rings: Stainless Steel
- Sink Flange/Stopper: Stainless Steel
- Drain Elbow: ABS
- Bearings: Permanently Lubricated, Sleeve Type
- Manual Reset Protector: Protection for Overload and Temp
- Shipping Weight: 9.4lb



Air Switch Available Separately

6140 Ulmerton Road Clearwater, FL 33760

Phone: (727) 388-9895

Fax: (727) 362-1281

For the most current Specification Sheet, go to www.pelicansinks.com





Pelicanator

1/2 HP Continuous Feed
Garbage Disposal

Technical Drawing

All product dimensions are nominal

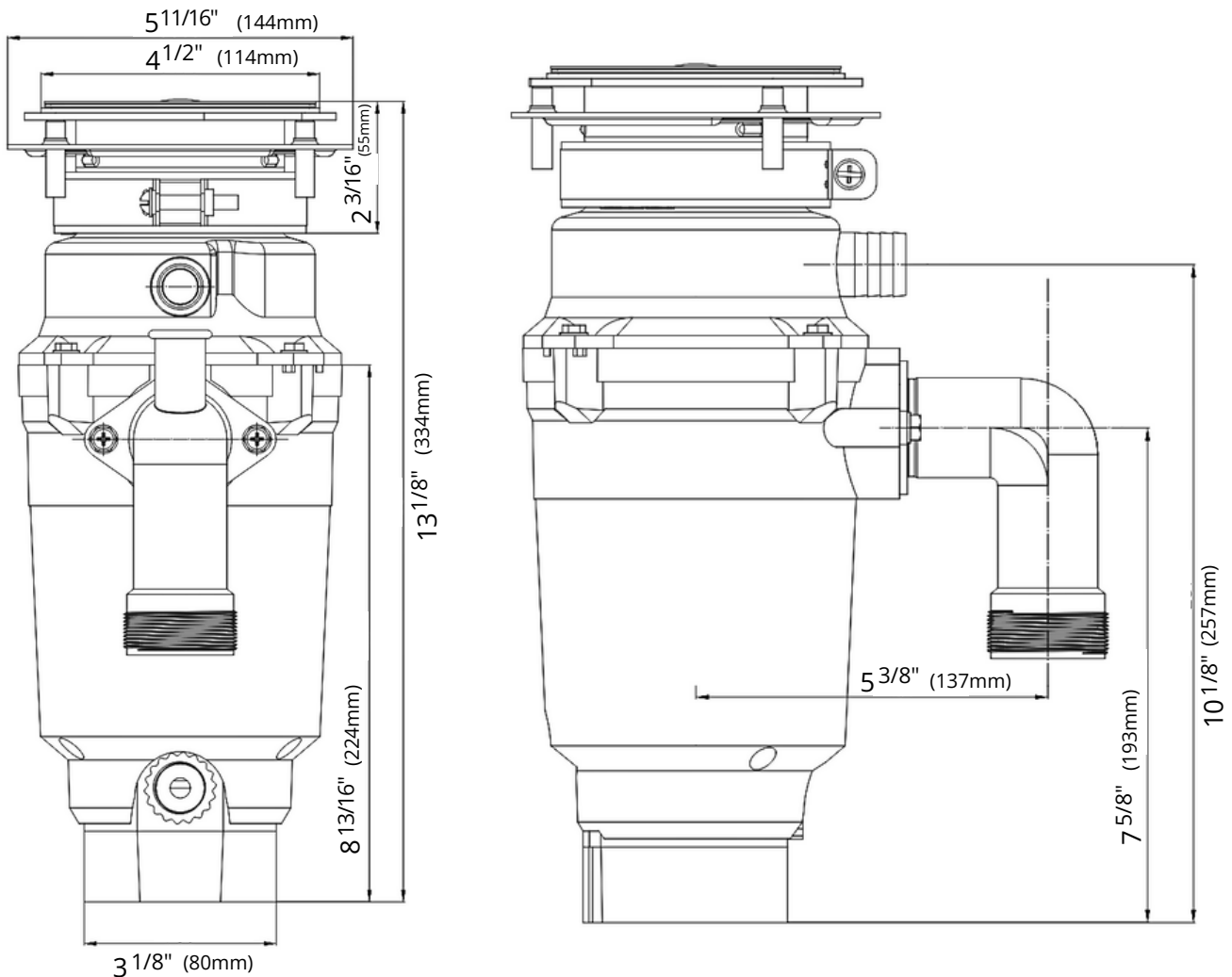

Installation Information

Install this product according to the installation instructions.

Limited Lifetime Warranty

See website for detailed warranty information.

In addition to the above, the Pelicanator Garbage Disposal comes with a 5-year replacement warranty against any mechanical or material defect.

6140 Ulmerton Road Clearwater, FL 33760

Phone: (727) 388-9895

Fax: (727) 362-1281

For the most current Specification Sheet, go to www.pelicansinks.com

