



**PL-1011**  
**8" Spread**  
*Pearl Series*  
Porcelain Sink

**Features**

- ADA Compliant
- Three Pre-Drilled Faucet Holes
- 8" Spread Between Holes
- Overflow Drain
- Nonporous - Hygienic



**Material**

- Vitreous China

**Installation**

- Self-Rimming

**Available Color/Finishes**

Intended for reference only

Color	Description
<input type="checkbox"/>	White

**Codes/Standards**

- ADA Compliant

---

6140 Ulmerton Road Clearwater, FL 33760

Phone: (727) 388-9895

Fax: (727) 362-1281

*For the most current Specification Sheet, go to [www.pelicansinks.com](http://www.pelicansinks.com)*





# PL-1011 8" Spread Pearl Series Porcelain Sink

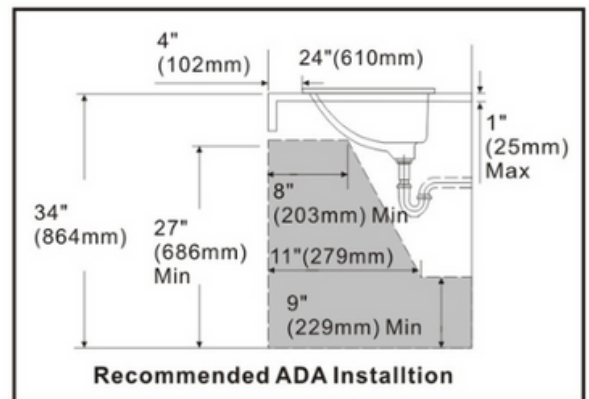
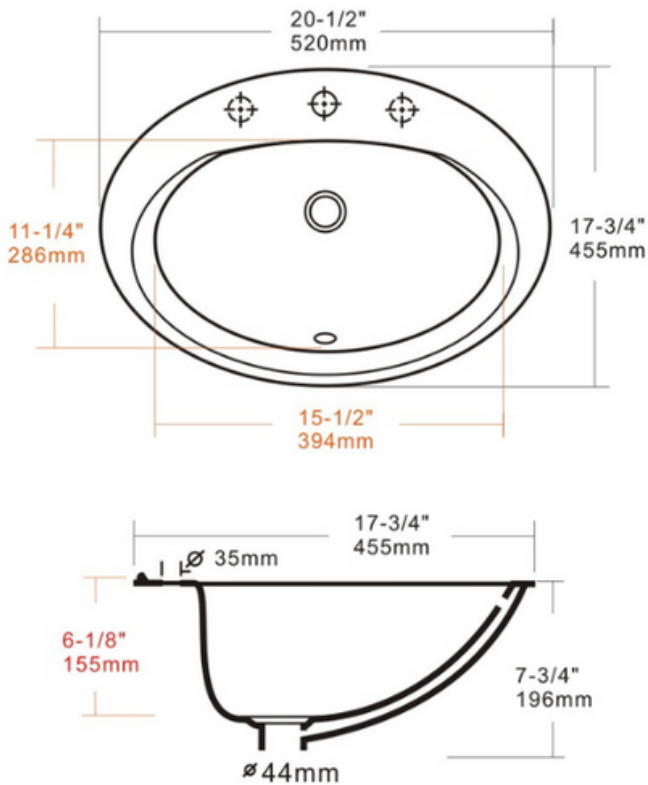

## Technical Information

All product dimensions are nominal

Exterior Measurements: 20 1/2" x 17 3/4" x 7 3/4"

Interior Measurements: 15 1/2" x 11 1/4" x 6 1/8"

Bowl Configuration: Single

Finish: Vitreous China

## Installation Information

Install this product according to the installation instructions.

## Limited Lifetime Warranty

See website for detailed warranty information.

6140 Ulmerton Road Clearwater, FL 33760

Phone: (727) 388-9895

Fax: (727) 362-1281

For the most current Specification Sheet, go to [www.pelicansinks.com](http://www.pelicansinks.com)

