



PL-300

Crystallite Series
Granite Composite Sinks

Features

- Single Bowl
- Available in 4 Colors
- Apron Front Design
- Stain / Scratch / Fade Resistant
- Made in Germany



Color Pictured: Chroma
*Pictured with Matching Chroma Strainer

Material





- Pure Quartz Sand with High Grade Acrylic Binders

Installation

- Apron Front, Undermount

Available Color/Finishes

Intended for reference only

Color	Description
	Alpina
	Chroma
	Concrete
	Onyx

6140 Ulmerton Road Clearwater, FL 33760
Phone: (727) 388-9895
Fax: (727) 362-1281

For the most current Specification Sheet, go to www.pelicansinks.com





PL-300

Crystallite Series
Granite Composite Sinks

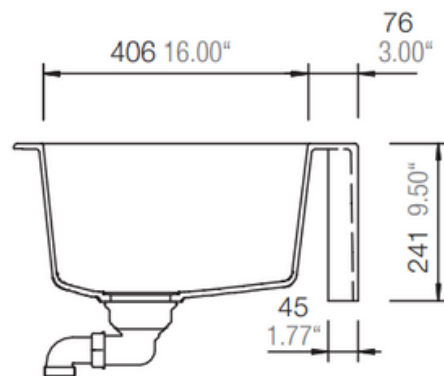
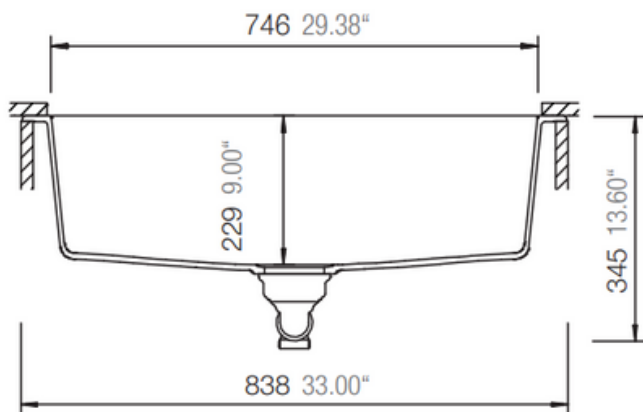
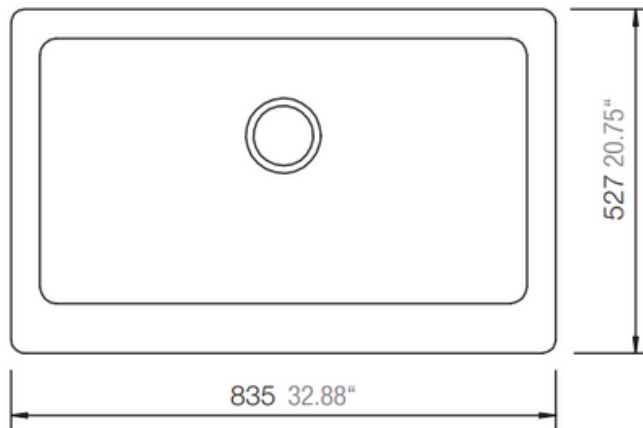

Technical Information

All product dimensions are nominal

Exterior Measurements: 32.88" x 20.75" x 9.50"

Interior Measurements: 29.38" x 16.00" x 9.50"

Bowl Configuration: Single

Installation Information

Install this product according to the installation instructions.

Limited Lifetime Warranty

See website for detailed warranty information.

6140 Ulmerton Road Clearwater, FL 33760

Phone: (727) 388-9895

Fax: (727) 362-1281

For the most current Specification Sheet, go to www.pelicansinks.com

