



# PL-8213

Fountain Series  
Kitchen Faucet

## Features

- Single Lever Handle Allows for Both On/Off Activation
- Ceramic Disc Valves Exceed Industry Longevity Standards for a Lifetime of Durable Performance
- 1.8 gal/min (6.84 l/min) Maximum Flow Rate [Max at 60 psi (4.1 bar)]
- Hot/Cold Indexing on Handle
- Flexible Supplies for Simplified Installation
- Backflow Protection
- Pull Out Sprayer



## Material

- Ceramic Cartridge
- Premium Metal Construction
- Finishing Resists Corrosion and Tarnishing

## Available Color/Finishes

Intended for reference only

Color	Description
	Brushed Nickel

## Installation

- Single Hole

## Codes/Standards

- ADA Compliant

---

6140 Ulmerton Road Clearwater, FL 33760

Phone: (727) 388-9895

Fax: (727) 362-1281

For the most current Specification Sheet, go to [www.pelicansinks.com](http://www.pelicansinks.com)





# PL-8213

Fountain Series  
Kitchen Faucet

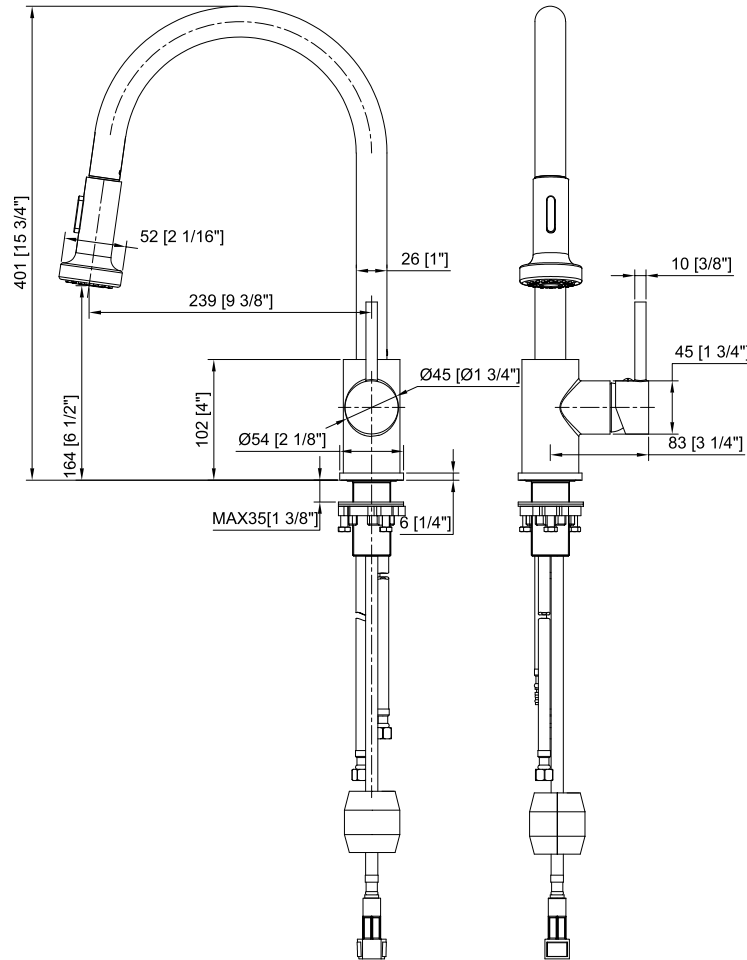

## Technical Information

All product dimensions are nominal

Spout Length: 9 3/8"

Spout Height: 6 1/2"

Overall Height: 15 3/4"

Flow Rate: 1.8 gal/min (6.84 l/min)

Pressure: 60 psi (4.1 bar)

Valve Body: Lead Free Brass

Drain Included: No

## Installation Information

Install this product according to the installation instructions.

## Limited Lifetime Warranty

See website for detailed warranty information.

6140 Ulmerton Road Clearwater, FL 33760

Phone: (727) 388-9895

Fax: (727) 362-1281

For the most current Specification Sheet, go to [www.pelicansinks.com](http://www.pelicansinks.com)

