



PL-8217

Fountain Series
Kitchen Faucet

Features

- Single Lever Handle Allows for Both On/Off Activation
- Ceramic Disc Valves Exceed Industry Longevity Standards for a Lifetime of Durable Performance
- 1.8 gal/min (6.84 l/min) Maximum Flow Rate [Max at 60 psi (4.1 bar)]
- Hot/Cold Indexing on Handle
- Flexible Supplies for Simplified Installation
- Backflow Protection
- Pull Out Sprayer



Material

- Ceramic Cartridge
- Premium Metal Construction
- Finishing Resists Corrosion and Tarnishing

Available Color/Finishes

Intended for reference only

Color

Description



Brushed Nickel



Oil Rubbed Bronze

Installation

- Single Hole

Codes/Standards

- ADA Compliant

6140 Ulmerton Road Clearwater, FL 33760

Phone: (727) 388-9895

Fax: (727) 362-1281

For the most current Specification Sheet, go to www.pelicansinks.com





PL-8217

Fountain Series
Kitchen Faucet

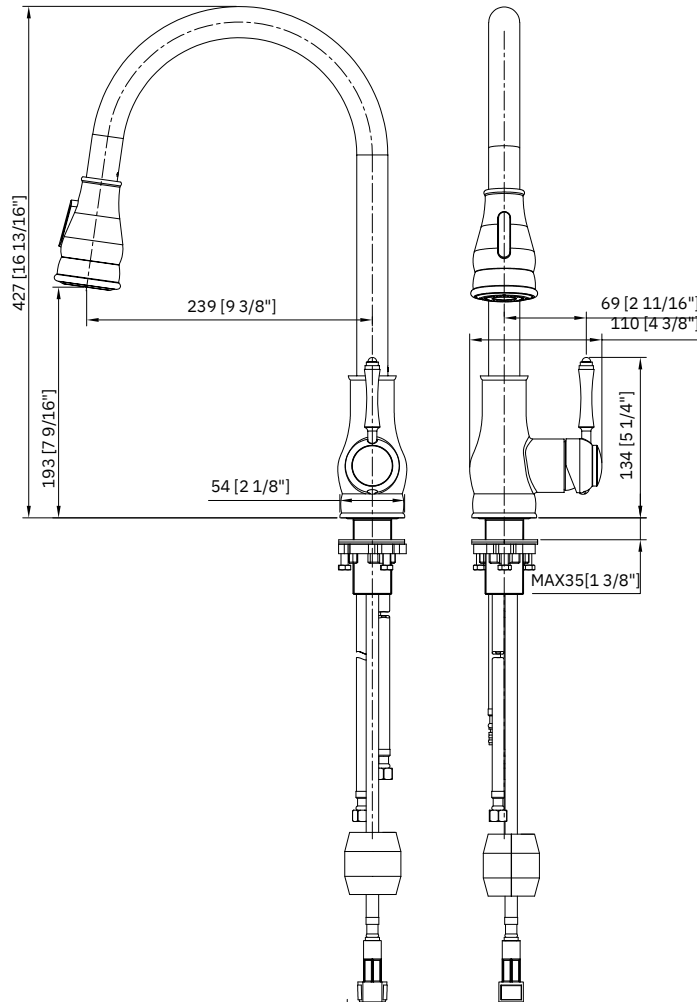

Technical Information

All product dimensions are nominal

Spout Length: 9 3/8"

Spout Height: 7 9/16"

Overall Height: 16 13/16"

Flow Rate: 1.8 gal/min (6.84 l/min)

Pressure: 60 psi (4.1 bar)

Valve Body: Lead Free Brass

Drain Included: No

Installation Information

Install this product according to the installation instructions.

Limited Lifetime Warranty

See website for detailed warranty information.

6140 Ulmerton Road Clearwater, FL 33760

Phone: (727) 388-9895

Fax: (727) 362-1281

For the most current Specification Sheet, go to www.pelicansinks.com

