



PL-HA108 ADA R15 18g

ADA Compliant Series
Stainless Steel Sink

Features

- Single Bowl
- ADA Compliant
- Handcrafted 15° Radius Corners
- Fitted Sound Deadening Pads
- ADA Compliant Bowl Depth

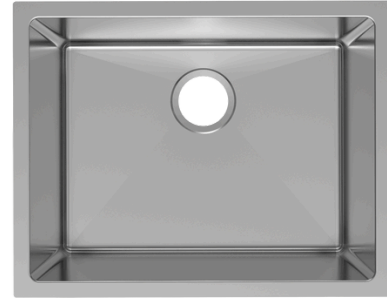

Material

- 18-Gauge Stainless Steel

Installation

- Undermount



Codes/Standards

- ADA Compliant

6140 Ulmerton Road Clearwater, FL 33760

Phone: (727) 388-9895

Fax: (727) 362-1281

For the most current Specification Sheet, go to www.buildpelican.com





PL-HA108 ADA R15 18g

ADA Compliant Series
Stainless Steel Sink

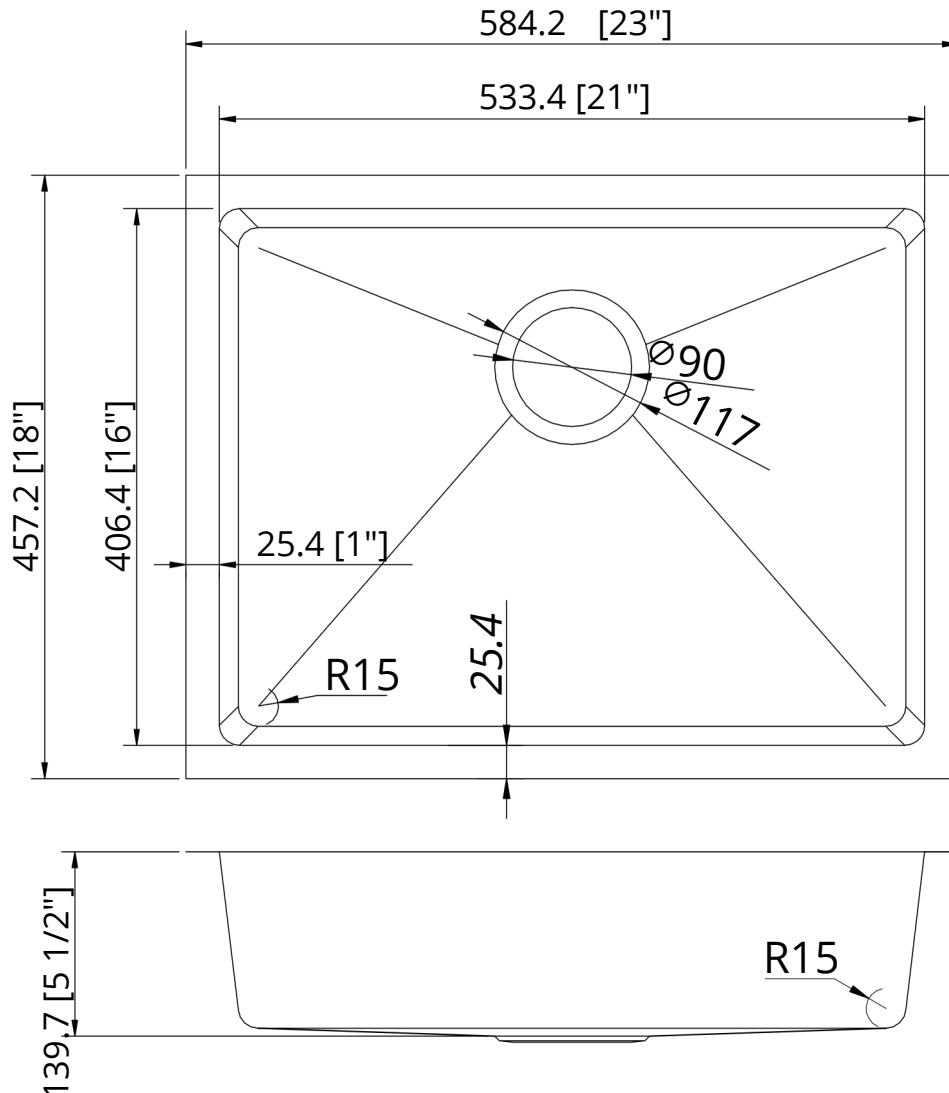

Technical Information

All product dimensions are nominal

Exterior Measurements: 23" x 18" x 5 1/2"

Interior Measurements: 21" x 16" x 5 1/2"

Bowl Configuration: Single

Installation Information

Install this product according to the installation instructions.

Limited Lifetime Warranty

See website for detailed warranty information.

6140 Ulmerton Road Clearwater, FL 33760

Phone: (727) 388-9895

Fax: (727) 362-1281

For the most current Specification Sheet, go to www.buildpelican.com

