



PL-HA117 ADA R0 18g

ADA Compliant Series
Stainless Steel Sink

Features

- Double Bowl
- ADA Compliant
- Handcrafted 0° Radius Corners
- Fitted Sound Deadening Pads
- ADA Compliant Bowl Depth

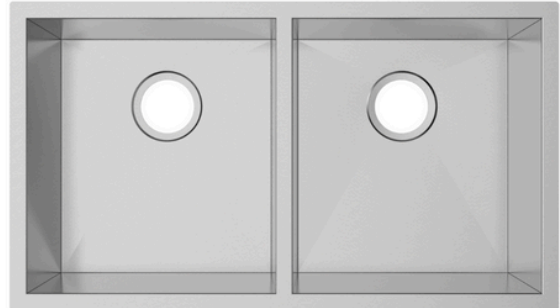

Material

- 18-Gauge Stainless Steel

Installation

- Undermount



Codes/Standards

- ADA COMPLIANT

6140 Ulmerton Road Clearwater, FL 33760

Phone: (727) 388-9895

Fax: (727) 362-1281

For the most current Specification Sheet, go to www.buildpelican.com





PL-HA117 ADA R0 18g

ADA Compliant Series
Stainless Steel Sink

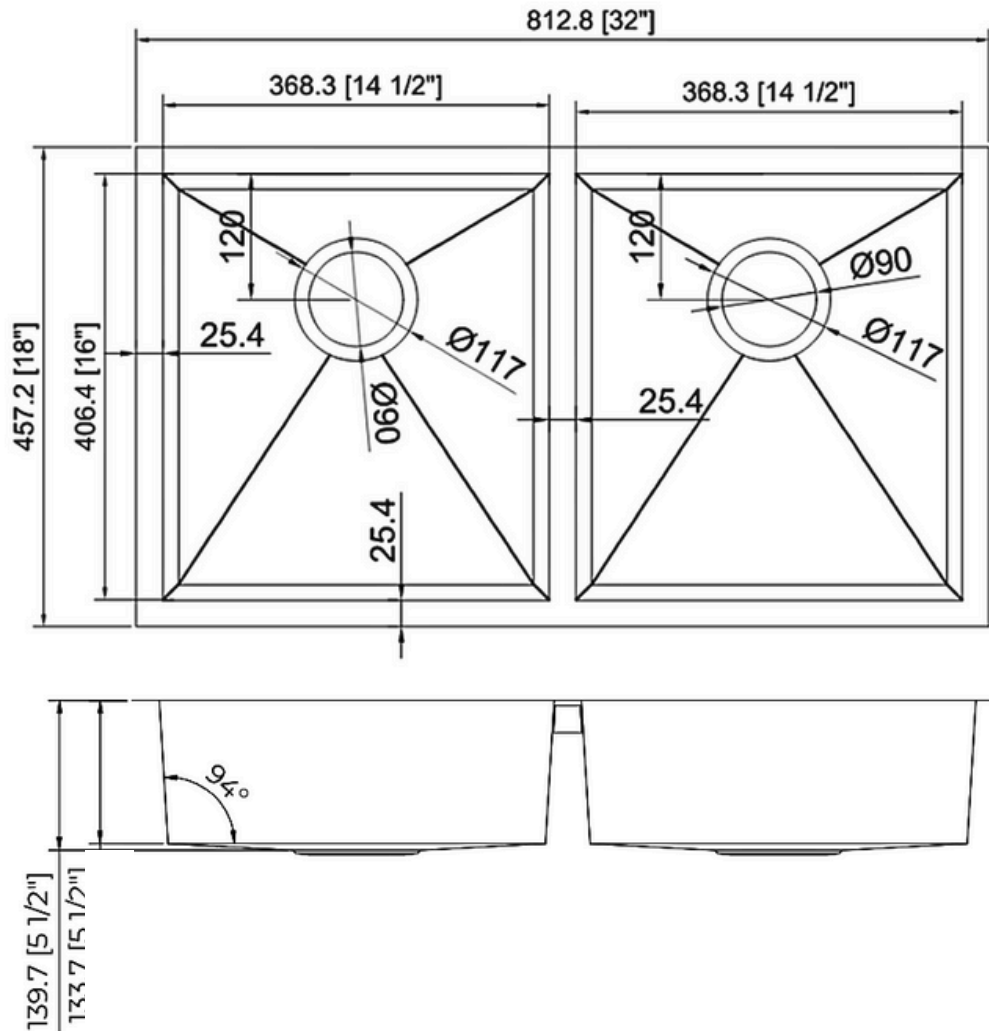

Technical Information

All product dimensions are nominal

Exterior Measurements: 32" x 18" x 5 1/2"

Bowl Measurements: 14 1/2" x 16" x 5 1/2"

Bowl Configuration: Double

Installation Information

Install this product according to the installation instructions.

Limited Lifetime Warranty

See website for detailed warranty information.

6140 Ulmerton Road Clearwater, FL 33760

Phone: (727) 388-9895

Fax: (727) 362-1281

For the most current Specification Sheet, go to www.buildpelican.com

