



PL-WS500

Crystallite Series
Granite Composite Sinks

Features

- Double Bowl
- Available in 4 Colors
- Stain / Scratch / Fade Resistant
- Graduated Ledge for Accessory Placement
- Includes a Wood Cutting Board, Roll-Out Drying Rack, and Bottom Grid
- Made in Germany



Color Pictured: Concrete
*Pictured with Matching Concrete Strainer

Material





- Pure Quartz Sand with High Grade Acrylic Binders

Installation

- Dualmount

Available Color/Finishes

Intended for reference only

Color	Description
	Alpina
	Chroma
	Concrete
	Onyx

6140 Ulmerton Road Clearwater, FL 33760
Phone: (727) 388-9895
Fax: (727) 362-1281

For the most current Specification Sheet, go to www.pelicansinks.com





PL-WS500
Crystallite Series
 Granite Composite Sinks

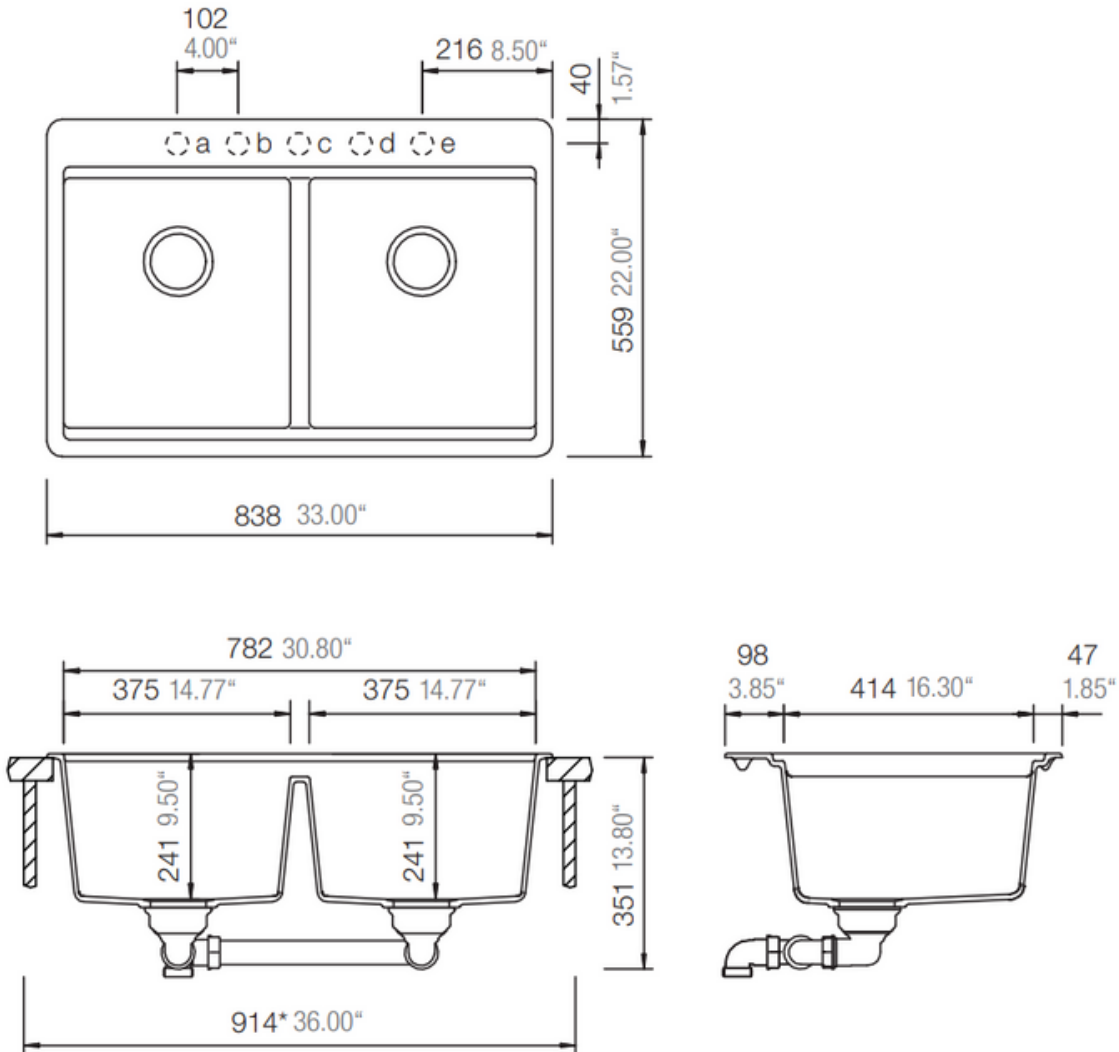

Technical Information

All product dimensions are nominal

Exterior Measurements: 33" x 22" x 9.50"

Bowl Measurements: 14.77" x 16.30" x 9.50"

Bowl Configuration: Double

Installation Information

Install this product according to the installation instructions.

Limited Lifetime Warranty

See website for detailed warranty information.

6140 Ulmerton Road Clearwater, FL 33760

Phone: (727) 388-9895

Fax: (727) 362-1281

For the most current Specification Sheet, go to www.pelicansinks.com

