

CU 300

GB Installation and operating instructions

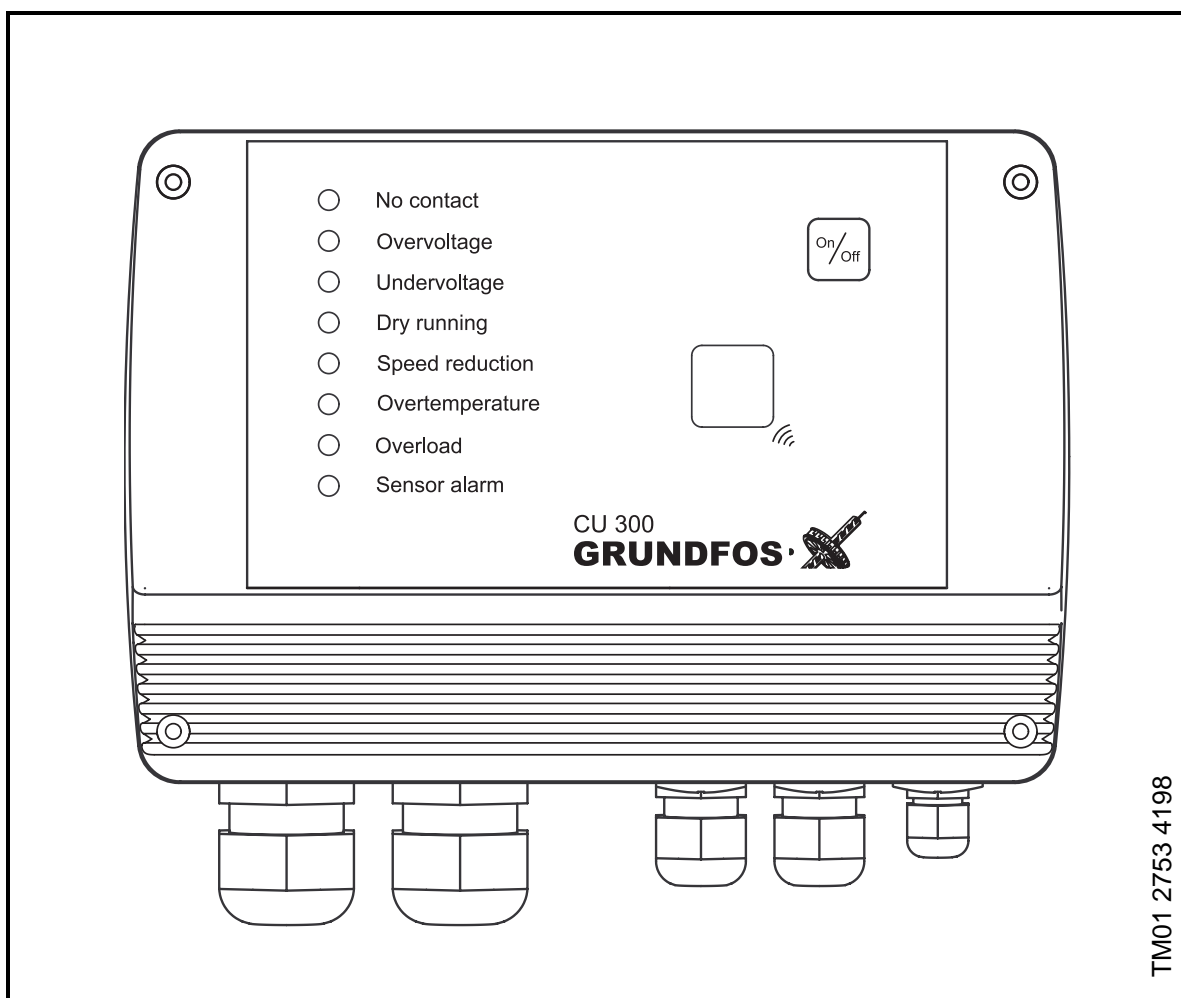

Declaration of Conformity

We **GRUNDFOS** declare under our sole responsibility that the product **CU 300**, to which this declaration relates, is in conformity with the Council Directives on the approximation of the laws of the EEC Member States relating to

- Electromagnetic compatibility (89/336/EEC).
Standards used: EN 55 014 and EN 55 014-2.
- Electrical equipment designed for use within certain voltage limits (73/23/EEC).
Standard used: EN 60 335-1.

Bjerringbro, 1st August 2000



Kenth Hvid Nielsen
Technical Manager

CONTENTS

	Page		
1. General	5	5. CU 300 with constant pressure control - two-pump operation	19
1.1 Expansion possibilities	5	5.1 Description	19
1.2 On/Off button	5	5.2 Function	19
2. CU 300 as an alarm unit	6	5.3 Positioning the pressure sensor	20
2.1 Description	6	5.4 System sizing	20
2.2 Installation	6	5.5 Installation	20
2.3 Location	6	5.6 Location	20
2.4 Mounting the CU 300	6	5.7 Mounting the CU 300	20
2.5 Electrical connection	7	5.8 Electrical connection	21
2.5.1 Mains supply	7	5.8.1 Auxiliary relay	21
2.5.2 Pump supply	7	5.8.2 Mains supply	21
2.5.3 Alarm signal relay	7	5.8.3 Pump supply	22
2.5.4 Digital input	7	5.8.4 Alarm signal relay	22
2.6 Description of dry-running protection	8	5.8.5 Flow switch and pressure sensor	22
2.6.1 Function	8	5.9 Settings	22
2.7 Settings	8	5.9.1 Required R100 settings	22
2.7.1 Required R100 settings	8	5.10 Start-up	22
2.8 Description of the dewatering function	8	6. CU 300 with sensors	23
2.8.1 Applications	8	6.1 General	23
2.8.2 Function	9	6.2 Sensor functioning	23
2.9 Settings	9	6.2.1 Alarm limits	23
2.9.1 Required R100 settings	9	6.2.2 Warning limits	23
2.9.2 Run/stop times	9	6.2.3 Start/stop limits	23
3. CU 300 with constant pressure control - 0 to 6 bar	10	6.3 Installation	24
3.1 Description	10	6.4 Location	24
3.2 Function	10	6.5 Mounting the CU 300	24
3.3 Positioning the pressure sensor	11	6.6 Electrical connection	25
3.4 System sizing	12	6.6.1 Mains supply	25
3.5 Installation	12	6.6.2 Pump supply	26
3.6 Location	12	6.6.3 Alarm signal relay	26
3.7 Mounting the CU 300	12	6.6.4 Sensors	26
3.8 Electrical connection	13	6.7 Settings	26
3.8.1 Mains supply	13	6.7.1 Required R100 settings	26
3.8.2 Pump supply	14	7. CU 300 connected to potentiometer	27
3.8.3 Alarm signal relay	14	7.1 Description	27
3.9 Settings	14	7.2 Installation	27
3.9.1 Required R100 settings	14	7.3 Location	27
3.10 Start-up	14	7.4 Mounting the CU 300	27
4. CU 300 with constant pressure control - 0 to 10 bar	15	7.5 Electrical connection	28
4.1 Description	15	7.5.1 Mains supply	28
4.2 Function	15	7.5.2 Pump supply	29
4.3 Positioning the pressure sensor	15	7.5.3 Alarm signal relay	29
4.4 System sizing	16	7.5.4 Potentiometer SPP 1	29
4.5 Installation	16	7.6 Settings	29
4.6 Location	16	7.6.1 Required R100 settings	29
4.7 Mounting the CU 300	16		
4.8 Electrical connection	17		
4.8.1 Mains supply	17		
4.8.2 Pump supply	18		
4.8.3 Alarm signal relay	18		
4.9 Settings	18		
4.9.1 Required R100 settings	18		
4.10 Start-up	18		

8. CU 300 connected to water meter	30	12. CU 300 with R100	43
8.1 Description	30	12.1 Menu OPERATION	47
8.2 Installation	30	12.1.1 Setpoint	47
8.3 Location	30	12.1.2 Operating mode	47
8.4 Mounting the CU 300	30	12.1.3 Alarm	47
8.5 Electrical connection	31	12.2 Menu STATUS	48
8.5.1 Mains supply	31	12.2.1 Operating mode	48
8.5.2 Pump supply	31	12.2.2 Actual setpoint and external setpoint	48
8.5.3 Alarm signal relay	31	12.2.3 Temperature	49
8.5.4 Water meter (pulse flow meter)	32	12.2.4 Speed	49
8.6 Settings	32	12.2.5 Power input and power consumption	49
8.6.1 Required R100 settings	32	12.2.6 Operating hours and number of starts	49
9. Constant water level	33	12.2.7 Sensor 1 and sensor 2	49
9.1 Description	33	12.2.8 Digital input	49
9.2 Function	33	12.2.9 Accumulated flow and energy per m ³	50
9.3 Installation	33	12.3 Menu LIMITS	50
9.4 Location	33	12.3.1 Sensor 1	50
9.5 Mounting the CU 300	33	12.3.2 Stop, sensor 1	50
9.6 Electrical connection	34	12.3.3 Warning, sensor 1	50
9.6.1 Mains supply	34	12.3.4 Alarm, sensor 1	50
9.6.2 Pump supply	35	12.3.5 Sensor 2	51
9.6.3 Alarm signal relay	35	12.3.6 Stop, sensor 2	51
9.6.4 Level sensor	35	12.3.7 Warning, sensor 2	51
9.7 Settings	35	12.3.8 Alarm, sensor 2	51
9.7.1 Required R100 settings	35	12.3.9 Stop type	51
10. CU 300 connected to RS-232, RS-485	36	12.3.10 Digital input	52
10.1 Description	36	12.3.11 Accumulated flow	52
10.2 CU 300 connected to a PC directly	36	12.3.12 Warning, temperature	52
10.3 Installation	37	12.4 Menu INSTALLATION	52
10.4 Location	37	12.4.1 Controller	52
10.5 Mounting the CU 300	37	12.4.2 External setpoint	53
10.6 Electrical connection	38	12.4.3 Automatic restart	53
10.6.1 Mains supply	38	12.4.4 Start delay	54
10.6.2 Pump supply	38	12.4.5 Run/Stop	54
10.6.3 Alarm signal relay	39	12.4.6 Dry-running stop	54
10.6.4 RS-485 input	39	12.4.7 Dry-running protection	54
10.6.5 RS-232 input	39	12.4.8 Maximum speed	54
10.6.6 Modem	39	12.4.9 Button on CU 300	55
10.6.7 PC Tool CU 300	39	12.4.10 Number	55
11. Alarm functions	40	13. Technical data	56
11.1 No contact	40	14. Disposal	57
11.2 Overvoltage	40		
11.3 Undervoltage	40		
11.4 Dry running	41		
11.5 Speed reduction	41		
11.6 Overtemperature	41		
11.7 Overload	42		
11.8 Sensor alarm	42		



Before beginning installation procedures, these installation and operating instructions should be studied carefully. The installation and operation should also be in accordance with local regulations and accepted codes of good practice.

1. General

The control unit CU 300 is developed for the SQE submersible pumps.

The CU 300 covers the voltage range:
1 x 100-240 V, +6%/–10%, 50/60 Hz, PE.

The CU 300 enables:

- control of the pump on the basis of sensor signals,
- setting of operating parameters, and
- monitoring of operation and alarm indication, if any.

The CU 300 indicates the following alarms:

- No contact,
- Overvoltage,
- Undervoltage,
- Dry running,
- Speed reduction,
- Overtemperature,
- Overload,
- Sensor alarm.

The individual alarms are described in detail in section 11. *Alarm functions.*

The CU 300 receives alarm signals from the motor for the following parameters:

- Dry running.
- Incipient pump/motor defect.
- Too high temperature in motor electronics.
- Supply failure.

As standard, the CU 300 incorporates an alarm signal relay.

1.1 Expansion possibilities

The CU 300 enables the use of:

- **Remote control R100:**
Wireless infra-red remote control by means of the R100 enables change of factory settings and monitoring of the installation by calling up actual operating data, e.g. speed, operating hours and power consumption.
- **External sensors:**
Reception of data from external sensors and control according to the data received, e.g. flow rate, pressure, water level and conductivity.
- **External potentiometer SPP 1:**
Manual speed control.

1.2 On/Off button

By means of the On/Off button on the CU 300, it is possible to

- start/stop the pump and
- reset possible alarms.

Fig. 1

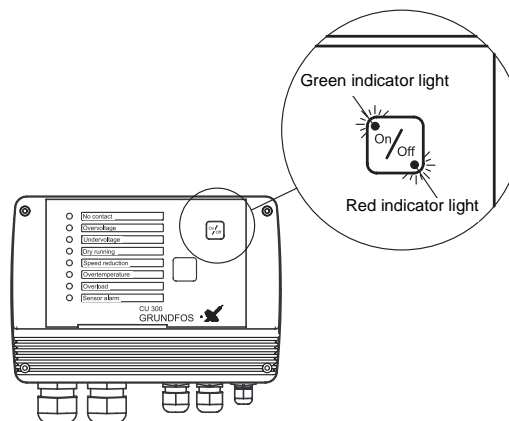

TM01 2829 2498

The green and red indicator lights in the On/Off button indicate pump operating condition as follows:

Indication	Description
Green indicator light permanently on.	Pump is operating.
Green indicator light flashing.	Pump has been stopped by either: <ul style="list-style-type: none"> • a sensor, • an external on/off switch or • a stop command from the R100.
Red indicator light permanently on.	Pump has been stopped by means of the On/Off button.*
Red indicator light flashing.	The CU 300 is communicating with the R100.

* If the On/Off button has been used to stop the pump, this button must also be used for restarting. If the On/Off button is pressed for minimum 5 seconds, the pump is started, irrespective of any active fault/alarm indications. When the On/Off button is released, the pump will stop.

2. CU 300 as an alarm unit

2.1 Description

When the CU 300 is connected to an SQE pump, any alarm will be indicated by one of the eight red indicator lights on the CU 300.

The indications are based on signals from the motor and from sensors, if installed. The individual alarms are described in detail in section 11. *Alarm functions*.

It is possible to connect an external alarm signal transmitter and an external on/off switch, see section 2.5 *Electrical connection* concerning connection, etc.

Fig. 2 shows an example of an installation with the CU 300 as an alarm unit.

Fig. 2

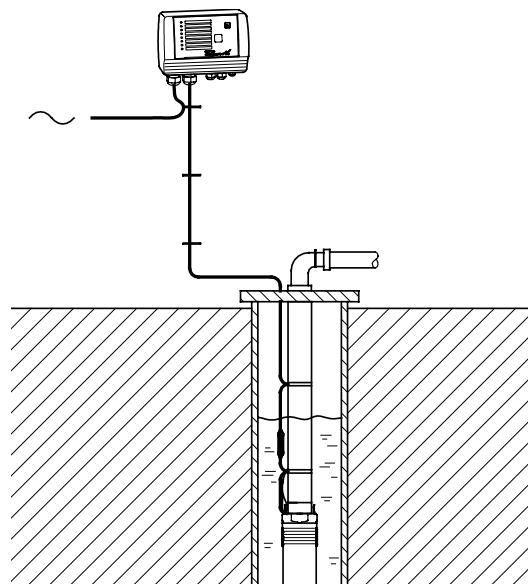

The CU 300 functions as an alarm unit for the pump. Furthermore, it is possible to communicate with the pump via the remote control R100, see also section 12. *CU 300 with R100*.

2.2 Installation



Before starting any work on the CU 300, make sure that the electricity supply has been switched off and that it cannot be accidentally switched on.

2.3 Location

The CU 300 can be placed both indoors and outdoors. It must not be exposed to direct sunlight.

2.4 Mounting the CU 300

The CU 300 is designed for wall mounting.

The box has six mounting holes ($\varnothing 4$), see fig. 3 (dimensions stated in mm).

The CU 300 must be mounted:

- horizontally (see fig. 3) to allow condensed water, if any, to escape.
- on a plane surface to avoid deformation of the box.

Fig. 3

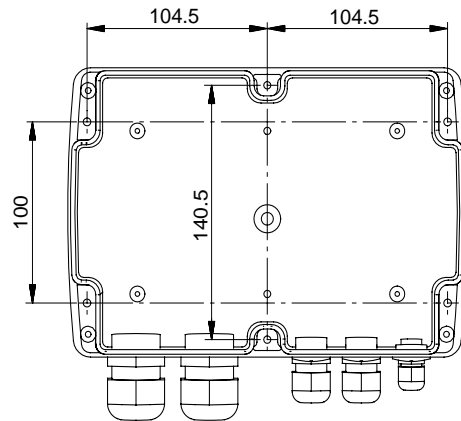

The CU 300 is supplied with a set of gaskets for the Pg screwed connections.

The gaskets are to be used for the connection of cables/wires to ensure tight connections (IP 55) and cable relief.

2.5 Electrical connection



Never make any connections in the CU 300 unit unless the electricity supply has been switched off. The CU 300 must be connected in accordance with the rules and standards in force for the application in question.

The supply voltage and frequency are marked on the nameplate. Make sure that the CU 300 is suitable for the electricity supply on which it will be used.

Fig. 4

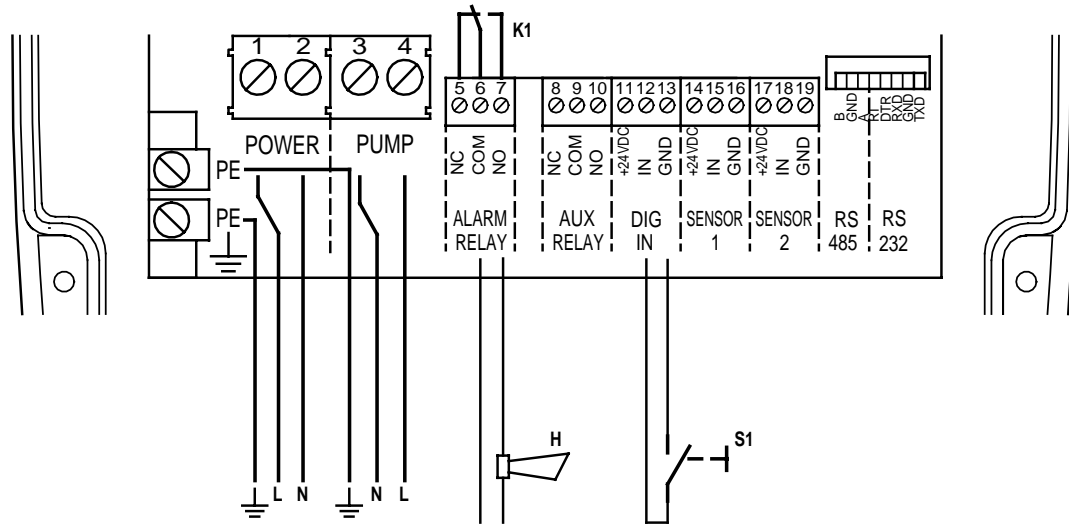

Legend:

Pos.	Description
S1	On/off switch for start/stop of pump.
H	Alarm signal transmitter (optional).
K1	Internal alarm signal relay. Relay data: 250 VAC, 8 A, AC1.

2.5.1 Mains supply

POWER, terminals 1, 2 and PE:

Connect terminals 1 and 2 to the phase and neutral leads of the mains supply. Each terminal can be connected to any of the two leads.

Connect the PE terminal to the green/yellow earth lead. Each PE terminal must be connected to an earth lead of its own.

Maximum cross-section of the leads to be connected is 6 mm².

Back-up fuse: Maximum 16 A.

Note: The leads of the mains supply must not be connected to terminals 3 and 4 (PUMP).

2.5.2 Pump supply

PUMP, terminals 3, 4 and PE:

Connect terminals 3 and 4 to the phase and neutral leads of the pump. Each terminal can be connected to any of the two leads.

Connect the PE terminal to the green/yellow earth lead. Each PE terminal must be connected to an earth lead of its own.

Maximum cross-section of the leads to be connected is 6 mm².

2.5.3 Alarm signal relay

ALARM RELAY, terminals 5, 6 and 7:

Connect terminals 5, 6 and 7 to the internal alarm signal relay as follows:

- Terminal 5 NC (normally closed).
- Terminal 6 COM (common).
- Terminal 7 NO (normally open).

The relay is activated when the alarm and warning limits are exceeded.

Manual or automatic restarting can be selected in the R100 display *12.4.3 Automatic restart*.

Manual restarting is carried out by means of the On/Off button on the CU 300.

2.5.4 Digital input

DIG IN, terminals 11, 12 and 13:

In fig. 4, the digital input is used to start and stop the pump.

The function of the digital input can be selected by means of the R100 in display *12.3.10 Digital input*.

TM01 3067 3398

2.6 Description of dry-running protection

When the pump sucks air, the pump power input decreases.

If the pump power input falls below the dry-running power limit set in the R100 display 12.4.6 *Dry-running stop*, the pump will stop and the CU 300 will indicate the dry-running alarm.

2.6.1 Function

The dry-running protection applies only if the motor speed lies within the "maximum speed" range (i.e. maximum speed less $1,000 \text{ min}^{-1}$), see fig. 5.

Normally, "maximum speed" is $10,700 \text{ min}^{-1}$. However, it can be reduced in the R100 display 12.4.8 *Maximum speed*. The dry-running power limit set in display 12.4.6 *Dry-running stop* must match the speed.

Changing the setpoint:

If the setpoint is changed by means of the R100 display 12.1.1 *Setpoint* or 12.4.2 *External setpoint*, the pump can be forced to run at a reduced speed in relation to the "maximum speed". The dry-running protection will not protect the pump if the reduced speed lies outside the "maximum speed" range (i.e. maximum speed less $1,000 \text{ min}^{-1}$), see fig. 5.

Constant pressure control:

In constant pressure control mode, the dry-running protection is active, as the motor will operate at "maximum speed" in connection with dry running.

Pump power input curve:

The curve shows the pump power input in relation to the pump speed.

Fig. 5

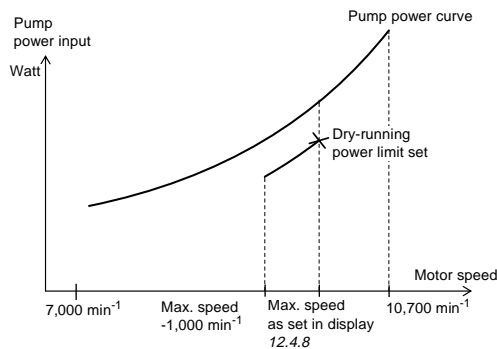

TM01 2689 2598

2.7 Settings

In the following section, the relevant R100 displays and settings are shown and described.

For a detailed description of the R100 displays, see section 12. *CU 300 with R100*. Each individual display has a number which refers to the section in which it is described in detail.

2.7.1 Required R100 settings

If the maximum speed of the pump has been reduced by more than $1,000 \text{ min}^{-1}$, the dry-running stop value must be changed. In order to change the dry-running protection function, the following R100 settings must be made:

Display	R100 setting
<p>12.4.7 <i>Dry-running protection</i></p>	<p>Set "Dry-running protection" to "Active".</p> <p>Note: In certain installations, it may be necessary to disable the dry-running protection. This is done in this display. The disabling applies to the dry-running power limit set in display 12.4.6 <i>Dry-running stop</i>. See fig. 5.</p>
<p>12.4.6 <i>Dry-running stop</i></p>	<p>Set the dry-running power limit, i.e. dry-running stop. See "Setting of dry-running power limit (dry-running stop)" below and section 13. <i>Technical data</i>.</p>

Setting of dry-running power limit (dry-running stop):

1. Start the pump against a closed discharge pipe.
2. Read the input power (P_1) in the R100 display 12.2.5 *Power input and power consumption*.
3. Calculate the dry-running power limit, $P_1 \times 0.9$ [W].
4. Set this value in the R100 display 12.4.6 *Dry-running stop*.

Note: If the pump is worn, a new setting of the dry-running power limit may be required.

2.8 Description of the dewatering function

When the pump sucks air, the pump power input decreases.

If the pump power input falls below the dry-running power limit set in the R100 display 12.4.6 *Dry-running stop*, the pump will stop.

During dewatering, the green indicator light in the On/Off button on the CU 300 is flashing to indicate that the pump has stopped.

2.8.1 Applications

The dewatering function can be used in applications where the pump often runs dry, e.g.:

- in boreholes with a low yield.
- in boreholes and building sites where the water table should be lowered.

2.8.2 Function

The dewatering function works as follows:

1. The pump is operating.
2. The pump sucks air due to a drop in the water level.
3. The load decreases, and consequently the pump power input does as well.
4. The pump stops when the power input falls to the dry-running power limit set in the R100 display 12.4.6 *Dry-running stop* in the INSTALLATION menu.

Note: The length of the stop time depends on the length of the run time according to a setting made in the R100 display 12.4.5 *Run/Stop* in the INSTALLATION menu.



2.9 Settings

In the following section, the relevant R100 displays and settings are shown and described.

For a detailed description of the R100 displays, see section 12. *CU 300 with R100*. Each individual display has a number which refers to the section in which it is described in detail.

2.9.1 Required R100 settings

In order to activate the dewatering function, the following R100 settings must be made:

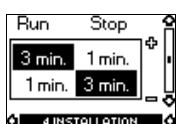
Display	R100 setting
<p>12.4.7 <i>Dry-running protection</i></p> 	Set "Dry-running protection" to "Active".
<p>12.4.6 <i>Dry-running stop</i></p> 	Set the dry-running power limit, i.e. dry-running stop. See "Setting of dry-running power limit (dry-running stop)" below.
<p>12.4.5 <i>Run/Stop</i></p> 	<p>Set the relation between run and stop times.</p> <p>Indication of operation: The dry-running alarm indication on the CU 300 is automatically disabled, when the setting is made in display 12.4.5 <i>Run/Stop</i>.</p> <p>To disable the dewatering function and return to dry-running protection, simply set the Run/Stop fields to "—" (not active).</p>

Setting of dry-running power limit (dry-running stop):

1. Start the pump against a closed discharge pipe.
2. Read the input power (P_1) in the R100 display 12.2.5 *Power input and power consumption*.
3. Calculate the dry-running power limit, $P_1 \times 0.9$ [W].
4. Set this value in the R100 display 12.4.6 *Dry-running stop*.

2.9.2 Run/stop times

The dewatering function means that there is a dependence between the period of time during which the pump is running, the run time, and the period of time during which the pump is stopped, the stop time.

Fig. 6 shows an example of run/stop times set in the R100 display 12.4.5 *Run/Stop*.

Fig. 6

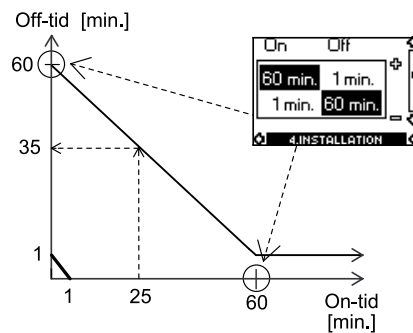

Explanation:

The run and stop times were set to 60 min. each. The pump has been running for 25 min. when dry running occurs. The pump will be stopped for 35 min. If the pump had been running for e.g. 2 hours (120 min.), the stop time would be 1 min.

TM01 2690 2298

3. CU 300 with constant pressure control - 0 to 6 bar

3.1 Description

Using constant pressure control enables automatic adjustment of the pump performance according to consumption. The system maintains a constant pressure within the maximum pump performance in spite of a varying water consumption.

Fig. 7 shows an example of an installation with constant pressure control within the range from 0 to 6 bar.

Fig. 7

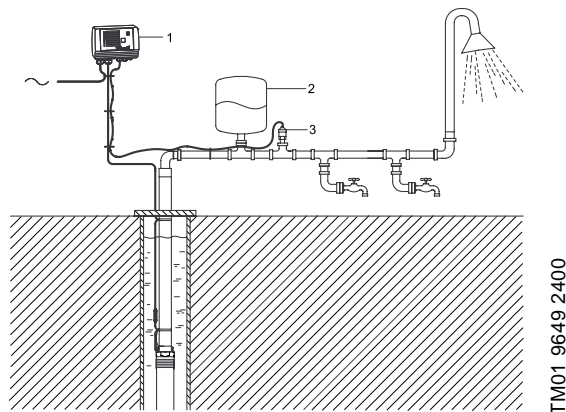

Pos.	Description
1	CU 300.
2	Diaphragm tank. Absorbs pressure variations.
3	Pressure sensor. The required pressure is set using the R100.

3.2 Function

The pressure is registered by means of the pressure sensor, which transmits a signal to the CU 300. The CU 300 adjusts the pump performance accordingly by changing the pump speed.

Mains borne signalling:

The communication between the CU 300 and the pump is effected via the power supply cable.

This communication principle is called mains borne signalling (or power line communication). Using this principle means that no additional cables to the pump are required.

The communication of data is effected by means of a high-frequency signal transmitted to the power supply cable and led into the electronics unit by means of signal coils incorporated in the motor and the CU 300 respectively.

When does the pump start?

The pump starts as a consequence of...

- a high flow or
- a low pressure or
- a combination of both.

To ensure that the pump is started when water is consumed, a flow detection is required. The flow is detected via pressure changes in the system. When water is consumed, the pressure will drop accordingly depending on the size of the diaphragm tank and the water flow:

- at a low flow, the pressure will drop slowly.
- at a high flow, the pressure will drop quickly.

See fig. 8.

Fig. 8

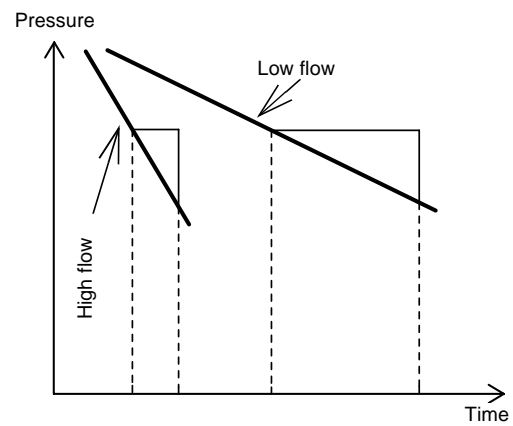

Note: When the pressure is dropping 0.1 bar/s or faster, the pump will start immediately.

If a diaphragm tank of 8 litres is used, the pump will start at a flow rate of approx. 0.18 m³/h.

Note: If a larger tank is used, the flow must be higher before the pump starts.

Consumption up to 0.18 m³/h:

The pump will start when the pressure has dropped to 0.5 bar below the pressure setting.

The pump will run until the pressure is 0.5 bar above the pressure set.

Flow detection:

During pump operation, i.e. when water is consumed, the CU 300 will adjust the pump speed to maintain a constant pressure. In order to stop the pump when no water is consumed, the CU 300 performs flow detection every 10 seconds.

The pump speed is reduced until a small pressure drop is registered. This pressure drop indicates that water is consumed and the pump speed is resumed, see fig. 9.

If the pump speed can be reduced without any pressure drop being registered, this indicates that no water is consumed. The diaphragm tank will be filled with water and the pump will be stopped.

Fig. 9

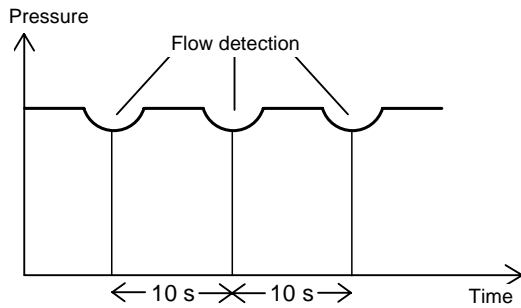

TM01 8546 0400

System limits:

Even though the CU 300 is controlling the pressure within ± 0.2 bar, bigger pressure variations may occur in the system.

If the consumption is suddenly changed, e.g. if a tap is opened, the water must start flowing before the pressure can be made constant again. Such dynamic variations depend on the pipework, but, typically, they will lie between 0.5 and 1 bar.

If the desired consumption is higher than the quantity the pump is able to deliver at the desired pressure, the pressure follows the pump curve as illustrated in fig. 10.

Fig. 10

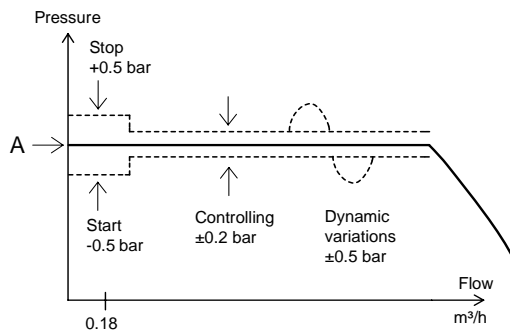

TM01 8634 0500

A = Pressure set

3.3 Positioning the pressure sensor

Pressure loss often causes inconvenience to the user. The CU 300 keeps the pressure constant in the place where the pressure sensor is positioned, see fig. 11.

Fig. 11

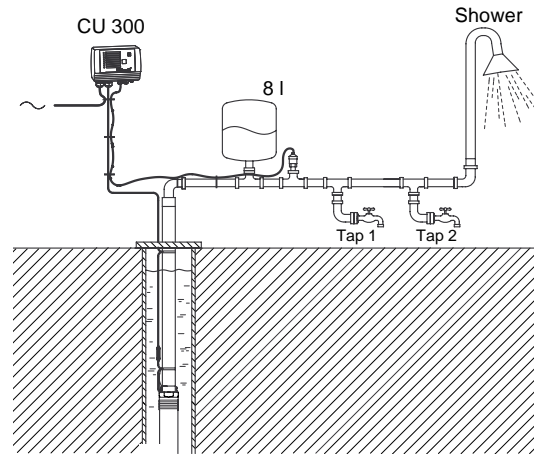

TM01 9670 2500

In fig. 11, tap 1 is placed close to the pressure sensor. Therefore, the pressure will be kept nearly constant at tap 1, as the friction loss is small. At the shower and tap 2, the friction loss is bigger. This, of course, depends on the piping. However, old and furred-up piping may cause inconvenience due to friction loss.

Therefore, it is recommended that the pressure sensor be positioned as close to the places of consumption as possible.

3.4 System sizing



The installation must be designed for the maximum pump pressure.

In normal installations with the CU 300 and an SQE pump set to constant pressure control, the required tank size is 8 litres. Bigger tanks can be used without causing any problems.

3.5 Installation



Before starting any work on the CU 300, make sure that the electricity supply has been switched off and that it cannot be accidentally switched on.

3.6 Location

The CU 300 can be placed both indoors and outdoors. It must not be exposed to direct sunlight.

3.7 Mounting the CU 300

The CU 300 is designed for wall mounting.

The box has six mounting holes ($\varnothing 4$), see fig. 12 (dimensions stated in mm).

The CU 300 must be mounted:

- horizontally (see fig. 12) to allow condensed water, if any, to escape.
- on a plane surface to avoid deformation of the box.

Fig. 12

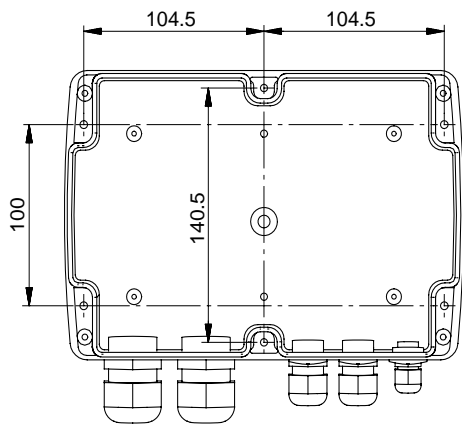

TM01 2824 2498

The CU 300 is supplied with a set of gaskets for the Pg screwed connections.

The gaskets are to be used for the connection of cables/wires to ensure tight connections (IP 55) and cable relief.

3.8 Electrical connection



Never make any connections in the CU 300 unit unless the electricity supply has been switched off. The CU 300 must be connected in accordance with the rules and standards in force for the application in question.

The supply voltage and frequency are marked on the nameplate. Make sure that the CU 300 is suitable for the electricity supply on which it will be used.

Fig. 13

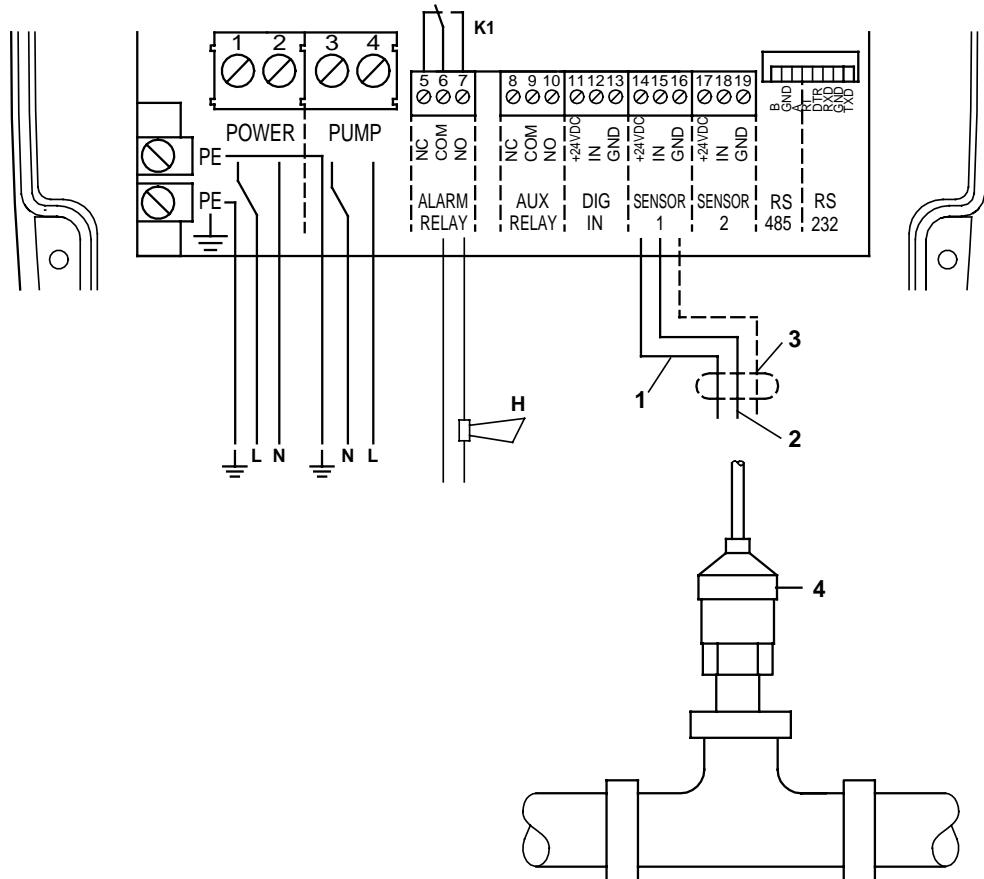

Legend:

Pos.	Description
1	Pressure sensor, brown lead, terminal 14.
2	Pressure sensor, black lead, terminal 15.
3	Pressure sensor, screen, terminal GND.
4	Pressure sensor. Must be connected to sensor input 1.
H	Alarm signal transmitter (optional).
K1	Internal alarm signal relay. Relay data: 250 VAC, 8 A, AC1.

3.8.1 Mains supply

POWER, terminals 1, 2 and PE:

Connect terminals 1 and 2 to the phase and neutral leads of the mains supply. Each terminal can be connected to any of the two leads.

Connect the PE terminal to the green/yellow earth lead. Each PE terminal must be connected to an earth lead of its own.

Maximum cross-section of the leads to be connected is 6 mm².

Back-up fuse: Maximum 16 A.

Note: The leads of the mains supply must not be connected to terminals 3 and 4 (PUMP).

TM01 9650 2400

3.8.2 Pump supply

PUMP, terminals 3, 4 and PE:

Connect terminals 3 and 4 to the phase and neutral leads of the pump. Each terminal can be connected to any of the two leads.

Connect the PE terminal to the green/yellow earth lead. Each PE terminal must be connected to an earth lead of its own.

Maximum cross-section of the leads to be connected is 6 mm².

3.8.3 Alarm signal relay

ALARM RELAY, terminals 5, 6 and 7:

Connect terminals 5, 6 and 7 to the internal alarm signal relay as follows:

- Terminal 5 NC (normally closed).
- Terminal 6 COM (common).
- Terminal 7 NO (normally open).

The relay operates when the alarm and warning limits are exceeded.

Manual or automatic restarting can be selected in the R100 display *12.4.3 Automatic restart*.

Manual restarting is carried out by means of the On/Off button on the CU 300.

3.9 Settings

In the following section, the relevant R100 displays and settings are shown and described.

For a detailed description of the R100 displays, see section *12. CU 300 with R100*. Each individual display has a number which refers to the section in which it is described in detail.

3.9.1 Required R100 settings

The following R100 settings must be made:

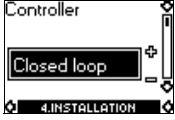
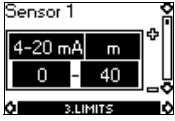
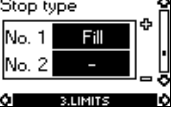
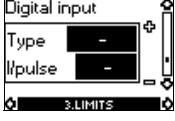
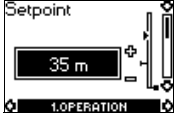
Display	R100 setting
<p><i>12.4.1 Controller</i></p> 	Select "Closed loop".
<p><i>12.3.1 Sensor 1</i></p> 	Set the sensor type. Example: <ul style="list-style-type: none"> • Sensor output signal (4-20 mA), • setting range unit (m), • setting range - head (0-40 m).
<p><i>12.3.9 Stop type</i></p> 	Set the stop type. <ul style="list-style-type: none"> • Sensor 1: "Fill". • Sensor 2: "-" (not active).
<p><i>12.3.10 Digital input</i></p> 	Set <ul style="list-style-type: none"> • Type to "-" (not active) and • I/pulse to "-" (not active).
<p><i>12.1.1 Setpoint</i></p> 	Set the desired head (m). Example: 35 m. Rule: The maximum setting of the setpoint corresponds to the maximum value set in display <i>12.3.1 Sensor 1</i> less 5 m. In this case, 40 less 5 = 35 m.

3.10 Start-up

Prior to start-up, the precharge pressure of the diaphragm tank must be set to 70% of the setpoint set in the R100 display *12.1.1 Setpoint*.

4. CU 300 with constant pressure control - 0 to 10 bar

4.1 Description

Using constant pressure control enables automatic adjustment of the pump performance according to consumption. The system maintains a constant pressure within the maximum pump performance in spite of a varying water consumption.

Fig. 14 shows an example of an installation with constant pressure control within the range from 0 to 10 bar.

Fig. 14

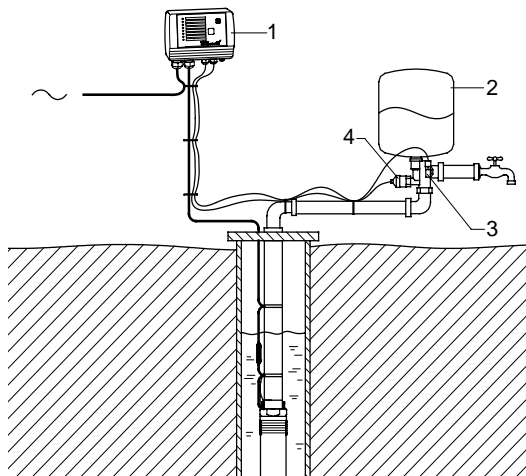

TM01 2653 2198

Pos.	Description
1	CU 300.
2	Diaphragm tank. Absorbs pressure variations.
3	Flow switch. The pump starts at once when water is consumed at the taps.
4	Pressure sensor. The required pressure is set using the R100.

4.2 Function

The pressure is registered by means of the pressure sensor and transmitted to the CU 300. The CU 300 adjusts the pump performance accordingly. To ensure that the pump is started when water is consumed, a flow switch must be included in the system. The required pressure (setpoint) is set in the R100 display 12.1.1 *Setpoint*.

- **Consumption up to 0.18 m³/h.**

The flow switch contact is open.

The pump starts when the pressure is equal to the setpoint less 0.5 bar. The pump will fill the tank and stop when the pressure is equal to the setpoint plus 0.5 bar. Consequently, the pump runs on/off operation.

- **Consumption above 0.18 m³/h.**

The flow switch contact is closed.

The pump starts when the flow switch contact closes and the speed control ensures that the pressure is kept constant. If the flow is below 0.18 m³/h and the flow switch contact is opened, the tank is filled to a pressure equal to the setpoint plus 0.5 bar. When this pressure is reached, the pump stops. Stopping is a combination of the flow switch contact opening and the pressure being equal to the setpoint plus 0.5 bar.

If the flow is larger than the quantity the pump is able to deliver at the desired pressure, the pressure follows the pump curve as illustrated in fig. 15.

Fig. 15

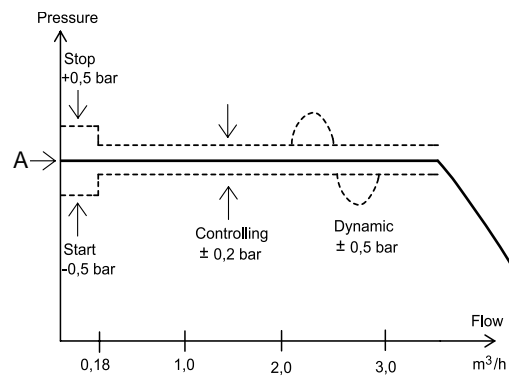

TM01 2833 2598

A = Required pressure

4.3 Positioning the pressure sensor

Pressure loss often causes inconvenience to the user. The CU 300 keeps the pressure constant in the place where the pressure sensor is positioned, see fig. 16.

Fig. 16

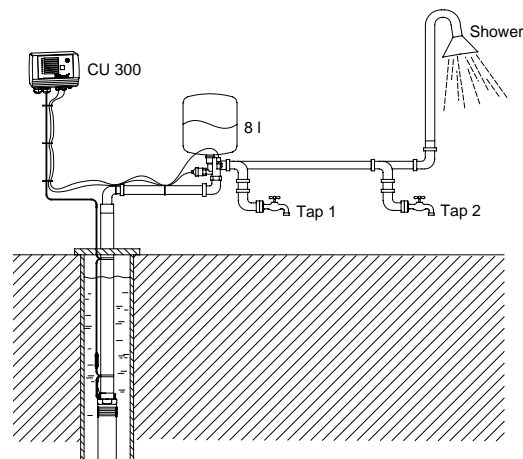

TM01 2834 2598

In fig. 16, tap 1 is placed close to the pressure sensor. Therefore, the pressure will be kept nearly constant at tap 1, as the friction loss is small. At the shower and tap 2, the friction loss is bigger. This, of course, depends on the piping. However, old and furred-up piping may cause inconvenience due to friction loss.

Therefore, it is recommended that the pressure sensor be positioned as close to the places of consumption as possible.

4.4 System sizing



The installation must be designed for the maximum pump pressure.

In normal installations with the CU 300 and an SQE pump set to constant pressure control, the required tank size is 8 litres. Bigger tanks can be used without causing any problems.

4.5 Installation



Before starting any work on the CU 300, make sure that the electricity supply has been switched off and that it cannot be accidentally switched on.

4.6 Location

The CU 300 can be placed both indoors and outdoors. It must not be exposed to direct sunlight.

4.7 Mounting the CU 300

The CU 300 is designed for wall mounting.

The box has six mounting holes ($\varnothing 4$), see fig. 17 (dimensions stated in mm).

The CU 300 must be mounted:

- horizontally (see fig. 17) to allow condensed water, if any, to escape.
- on a plane surface to avoid deformation of the box.

Fig. 17

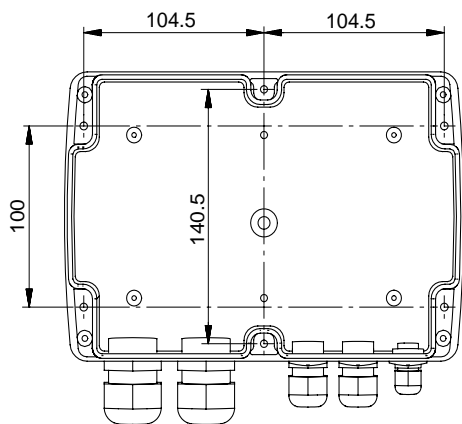

TM01 2824 2498

The CU 300 is supplied with a set of gaskets for the Pg screwed connections.

The gaskets are to be used for the connection of cables/wires to ensure tight connections (IP 55) and cable relief.

4.8 Electrical connection



Never make any connections in the CU 300 unit unless the electricity supply has been switched off. The CU 300 must be connected in accordance with the rules and standards in force for the application in question.

The supply voltage and frequency are marked on the nameplate. Make sure that the CU 300 is suitable for the electricity supply on which it will be used.

Fig. 18

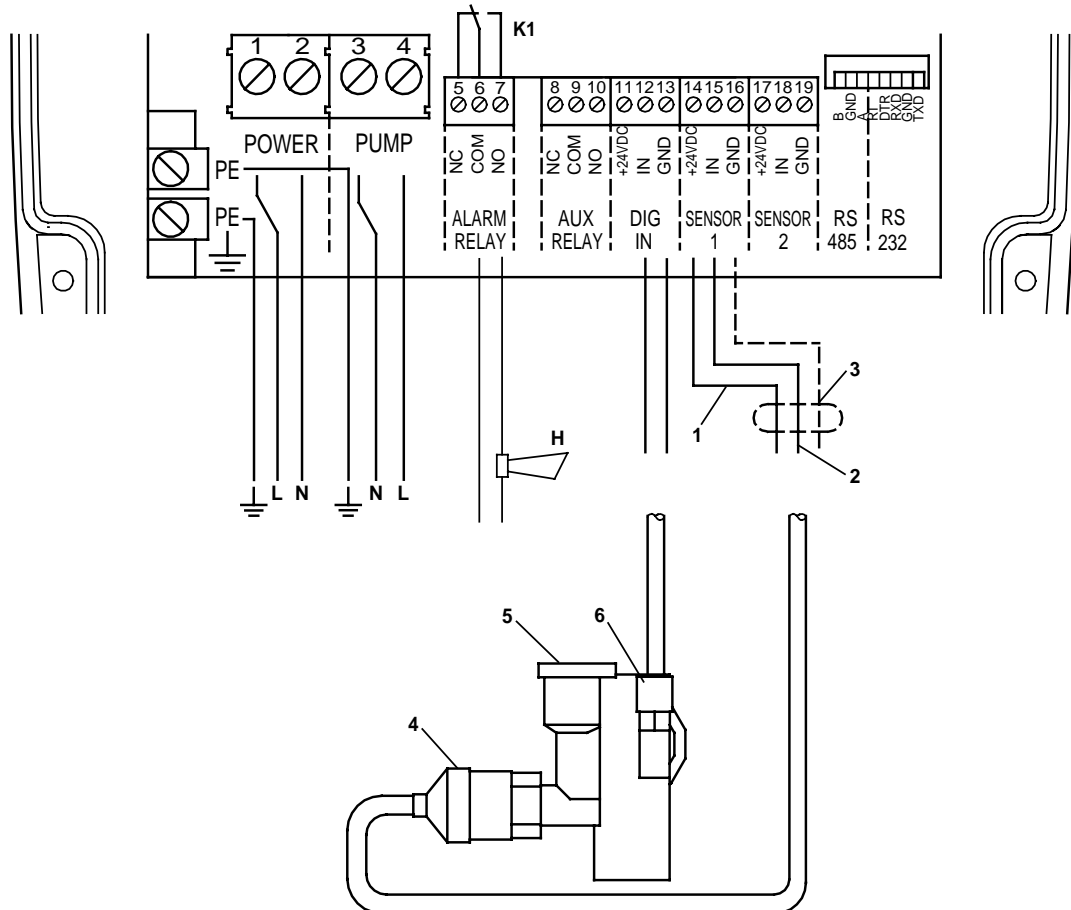

Legend:

Pos.	Description
1	Pressure sensor, brown lead, terminal 14.
2	Pressure sensor, black lead, terminal 15.
3	Pressure sensor, screen, terminal GND.
4	Pressure sensor. Must be connected to sensor input 1.
5	Diaphragm tank connection.
6	Flow switch. Must be connected to the digital input, terminals 12 and 13. Cannot be connected wrongly.
H	Alarm signal transmitter (optional).
K1	Internal alarm signal relay. Relay data: 250 VAC, 8 A, AC1.

4.8.1 Mains supply

POWER, terminals 1, 2 and PE:

Connect terminals 1 and 2 to the phase and neutral leads of the mains supply. Each terminal can be connected to any of the two leads.

Connect the PE terminal to the green/yellow earth lead. Each PE terminal must be connected to an earth lead of its own.

Maximum cross-section of the leads to be connected is 6 mm².

Back-up fuse: Maximum 16 A.

Note: The leads of the mains supply must not be connected to terminals 3 and 4 (PUMP).

TM01 3089 3398

4.8.2 Pump supply

PUMP, terminals 3, 4 and PE:

Connect terminals 3 and 4 to the phase and neutral leads of the pump. Each terminal can be connected to any of the two leads.

Connect the PE terminal to the green/yellow earth lead. Each PE terminal must be connected to an earth lead of its own.

Maximum cross-section of the leads to be connected is 6 mm².

4.8.3 Alarm signal relay

ALARM RELAY, terminals 5, 6 and 7:

Connect terminals 5, 6 and 7 to the internal alarm signal relay as follows:

- Terminal 5 NC (normally closed).
- Terminal 6 COM (common).
- Terminal 7 NO (normally open).

The relay operates when the alarm and warning limits are exceeded.

Manual or automatic restarting can be selected in the R100 display *12.4.3 Automatic restart*.

Manual restarting is carried out by means of the On/Off button on the CU 300.

4.9 Settings

In the following section, the relevant R100 displays and settings are shown and described.

For a detailed description of the R100 displays, see section *12. CU 300 with R100*. Each individual display has a number which refers to the section in which it is described in detail.

4.9.1 Required R100 settings

The following R100 settings must be made:

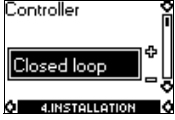
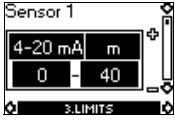
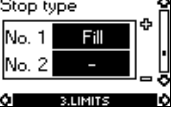
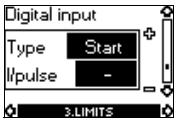
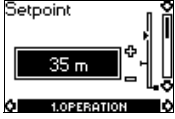
Display	R100 setting
<p><i>12.4.1 Controller</i></p> 	Select "Closed loop".
<p><i>12.3.1 Sensor 1</i></p> 	Set the sensor type. Example: <ul style="list-style-type: none"> • Sensor output signal (4-20 mA), • setting range unit (m), • setting range - head (0-40 m).
<p><i>12.3.9 Stop type</i></p> 	Set the stop type. <ul style="list-style-type: none"> • Sensor 1: "Fill". • Sensor 2: "-" (not active).
<p><i>12.3.10 Digital input</i></p> 	Set <ul style="list-style-type: none"> • Type to "Start" and • I/pulse to "-" (not active).
<p><i>12.1.1 Setpoint</i></p> 	Set the desired head (m). Example: 35 m. Rule: The maximum setting of the setpoint corresponds to the maximum value set in display <i>12.3.1 Sensor 1</i> less 5 m. In this case, 40 less 5 = 35 m.

4.10 Start-up

Prior to start-up, the precharge pressure of the diaphragm tank must be set to 70% of the setpoint set in the R100 display *12.1.1 Setpoint*.

5. CU 300 with constant pressure control - two-pump operation

5.1 Description

Using constant pressure control in connection with two-pump operation enables automatic adjustment of the pump performance according to the consumption in systems where a high flow is required. The system maintains a constant pressure within the maximum pump performance in spite of a varying water consumption.

Note: During two-pump operation, the two pumps **must** have the same nominal flow, e.g. two SQE 2.

Fig. 19 shows an example of a two-pump installation with constant pressure control.

Fig. 19

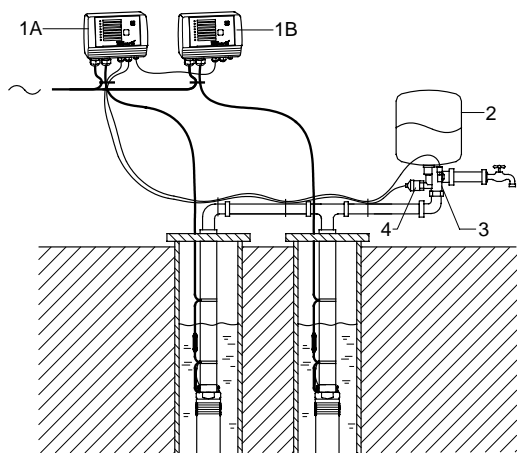

TM01 2654 1999

Pos.	Description
1A, 1B	1A = CU 300 (master), 1B = CU 300 (slave).
2	Diaphragm tank, minimum 24 litres. Absorbs pressure variations.
3	Flow switch. The pump starts at once when water is consumed at the taps.
4	Pressure sensor. The required pressure is set using the R100.

5.2 Function

The pressure is registered by means of the pressure sensor and transmitted to the CU 300 (master). The CU 300 adjusts the pump speed to ensure that the pressure is kept constant. To ensure that the pump connected to the CU 300 (master) is started when water is consumed, a flow switch must be included in the system.

Set the CU 300 (master) to the desired pressure (setpoint) in the R100 display *12.1.1 Setpoint*.

- **Consumption up to 0.18 m³/h.**
The flow switch contact is open.
The pump connected to the CU 300 (master) starts when the pressure is equal to the setpoint less 0.5 bar. The pump will fill the tank and stop when the pressure is equal to the setpoint plus 0.5 bar. Consequently, the pump runs on/off operation.

- **Consumption above 0.18 m³/h.**
The flow switch contact is closed.
The pump connected to the CU 300 (master) starts when the flow switch contact closes and the speed control ensures that the pressure is kept constant.

If the flow is lower than 0.18 m³/h and the flow switch contact is opened, the tank is filled to a pressure equal to the setpoint plus 0.5 bar. When this pressure is reached, the pump stops. Stopping is a combination of the flow switch contact opening and the pressure being equal to the setpoint plus 0.5 bar.

If the consumption exceeds the quantity the pump connected to the CU 300 (master) is able to deliver, the pressure in the diaphragm tank will fall.

The pump connected to the CU 300 (slave) will be started in the two following situations:

1. If the pressure in the diaphragm tank falls to 1 bar below the setpoint or
2. if the pump connected to the CU 300 (master) has been operating at maximum performance for more than 5 seconds and the water requirement has increased.

The pump connected to the CU 300 (slave) will be stopped in the three following situations:

1. If the system pressure is 1 bar higher than the setpoint or
2. if the pump connected to the CU 300 (master) has been operating at minimum performance for more than 5 seconds and the water requirement has fallen or
3. if the flow switch indicates "no flow" and the system pressure is 0.5 bar higher than the setpoint.

If the flow is larger than the quantity the pumps are able to deliver at the desired pressure, the pressure follows the pump curve as illustrated in fig. 20.

Fig. 20

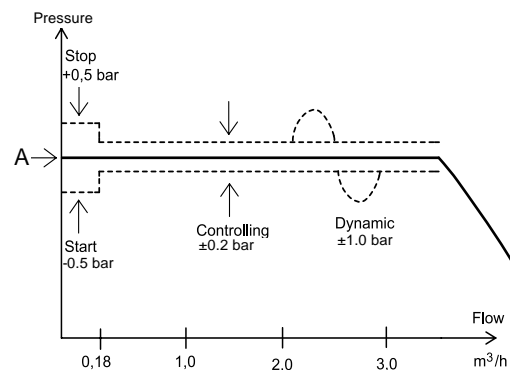

TM01 2833 2598

A = Required pressure

5.3 Positioning the pressure sensor

See section 4.3 *Positioning the pressure sensor*.

5.4 System sizing



The installation must be designed for the maximum pump pressure.

In two-pump installations set to constant pressure control, the required tank size is 24 litres. Bigger tanks can be used without causing any problems.

5.5 Installation



Before starting any work on the CU 300, make sure that the electricity supply has been switched off and that it cannot be accidentally switched on.

5.6 Location

The CU 300 can be placed both indoors and outdoors. It must not be exposed to direct sunlight.

5.7 Mounting the CU 300

The CU 300 is designed for wall mounting.

The box has six mounting holes ($\varnothing 4$), see fig. 21 (dimensions stated in mm).

The CU 300 must be mounted:

- horizontally (see fig. 21) to allow condensed water, if any, to escape.
- on a plane surface to avoid deformation of the box.

Fig. 21

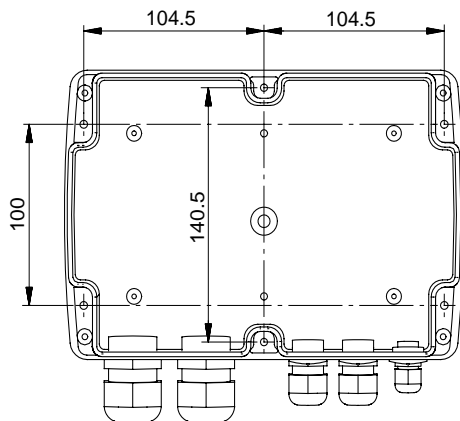

TM01 2824 2498

The CU 300 is supplied with a set of gaskets for the Pg screwed connections.

The gaskets are to be used for the connection of cables/wires to ensure tight connections (IP 55) and cable relief.

5.8 Electrical connection



Never make any connections in the CU 300 unit unless the electricity supply has been switched off. The CU 300 must be connected in accordance with the rules and standards in force for the application in question.

The supply voltage and frequency are marked on the nameplate. Make sure that the CU 300 is suitable for the electricity supply on which it will be used.

Fig. 22

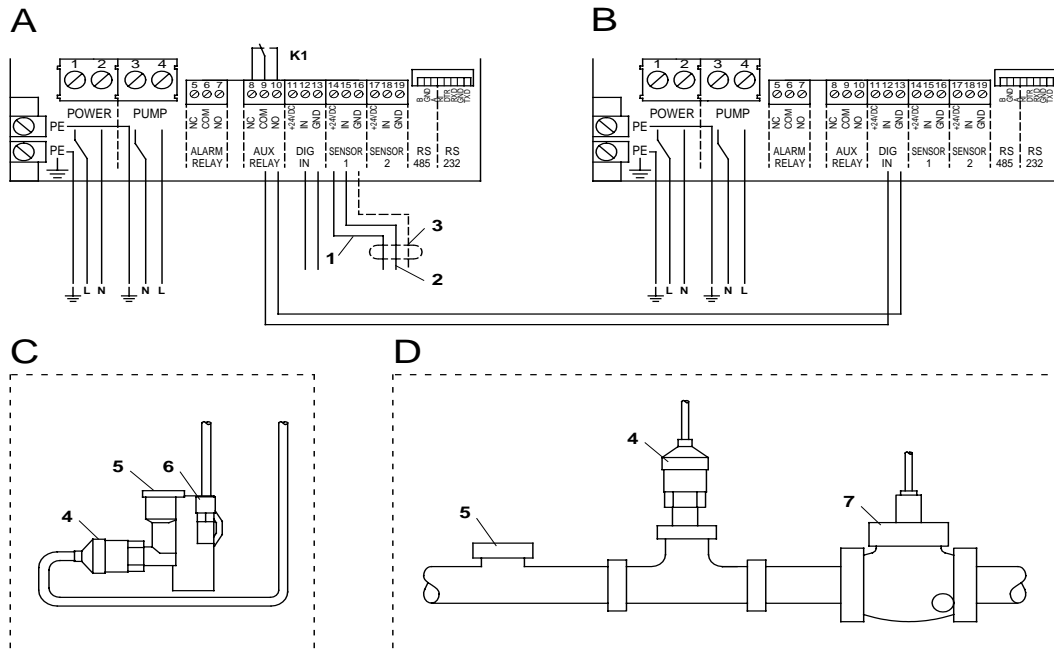

Legend:

Pos.	Description
A	CU 300 (master).
B	CU 300 (slave).
C	Installation for $Q < 7 \text{ m}^3/\text{h}$.
D	Installation for $Q > 7 \text{ m}^3/\text{h}$.
1	Pressure sensor, brown lead, terminal 14.
2	Pressure sensor, black lead, terminal 15.
3	Pressure sensor, screen, terminal GND.
4	Pressure sensor. Must be connected to sensor input 1.
5	Diaphragm tank connection.
6	Flow switch ($Q < 7 \text{ m}^3/\text{h}$). Must be connected to the digital input, terminals 12 and 13. Cannot be connected wrongly.
7	Flow switch ($Q > 7 \text{ m}^3/\text{h}$). Must be connected to the digital input, terminals 12 and 13. Cannot be connected wrongly.
K1	Internal alarm signal relay. Relay data: 250 VAC, 8 A, AC1.

5.8.1 Auxiliary relay

Connect the CU 300 (master) to the CU 300 (slave) as follows:

Connections	
CU 300 (master)	CU 300 (slave)
Terminal 9 (COM)	Terminal 12 (IN)
Terminal 10 (NO)	Terminal 13 (GND)

See fig. 22.

5.8.2 Mains supply

POWER, terminals 1, 2 and PE:

Connect terminals 1 and 2 to the phase and neutral leads of the mains supply, see fig. 18. Each terminal can be connected to any of the two leads. Connect the PE terminal to the green/yellow earth lead. Each PE terminal must be connected to an earth lead of its own.

Maximum cross-section of the leads to be connected is 6 mm^2 .

Back-up fuse: Maximum 16 A.

Note: The leads of the mains supply must not be connected to terminals 3 and 4 (PUMP).

TM01 9671 2500

5.8.3 Pump supply

PUMP, terminals 3, 4 and PE:

Connect terminals 3 and 4 to the phase and neutral leads of the pump, see fig. 18. Each terminal can be connected to any of the two leads.

Connect the PE terminal to the green/yellow earth lead. Each PE terminal must be connected to an earth lead of its own.

Maximum cross-section of the leads to be connected is 6 mm².

5.8.4 Alarm signal relay

ALARM RELAY, terminals 5, 6 and 7:

Connect terminals 5, 6 and 7 to the internal alarm signal relay as follows:

- Terminal 5 NC (normally closed).
- Terminal 6 COM (common).
- Terminal 7 NO (normally open).

The relay operates when the alarm and warning limits are exceeded.

Manual or automatic restarting can be selected in the R100 display 12.4.3 *Automatic restart*.

Manual restarting is carried out by means of the On/Off button on the CU 300.

5.8.5 Flow switch and pressure sensor

Connect the flow switch and the pressure sensor to the CU 300 (A = master) as illustrated in fig. 22.

Flow switch	
Pump type	Product number
SQE 1	96 03 73 32
SQE 2, SQE 3, SQE 5, SQE 7	96 03 75 59

5.9 Settings

In the following section, the relevant R100 displays and settings are shown and described.

For a detailed description of the R100 displays, see section 12. *CU 300 with R100*. Each individual display has a number which refers to the section in which it is described in detail.

5.9.1 Required R100 settings

The following R100 settings must be made on the CU 300 (master):

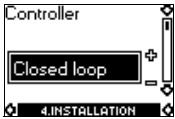
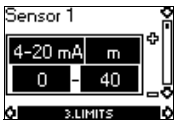
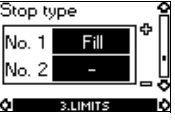
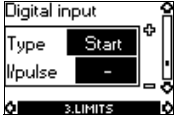
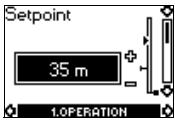
Display	R100 setting
<p>12.4.1 <i>Controller</i></p> 	Select "Closed loop".
<p>12.3.1 <i>Sensor 1</i></p> 	Set the sensor type. Example: <ul style="list-style-type: none"> • Sensor output signal (4-20 mA), • setting range unit (m), • setting range - head (0-40 m).
<p>12.3.9 <i>Stop type</i></p> 	Set the stop type. <ul style="list-style-type: none"> • Sensor 1: "Fill". • Sensor 2: "-" (not active).
<p>12.3.10 <i>Digital input</i></p> 	Set <ul style="list-style-type: none"> • Type to "Start" and • I/pulse to "-" (not active).
<p>12.1.1 <i>Setpoint</i></p> 	Set the desired head (m). Example: 35 m. Rule: The maximum setting of the setpoint corresponds to the maximum value set in display 12.3.1 <i>Sensor 1</i> less 5 m. In this case, 40 less 5 = 35 m.

The following R100 setting must be made on the CU 300 (slave):

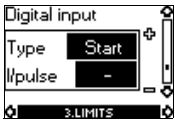
Display	R100 setting
<p>12.3.10 <i>Digital input</i></p> 	Set <ul style="list-style-type: none"> • Type to "Start" and • I/pulse to "-" (not active).

5.10 Start-up

Prior to start-up, the precharge pressure of the diaphragm tank must be set to 70% of the setpoint set in the R100 display 12.1.1 *Setpoint*.

6. CU 300 with sensors

6.1 General

The CU 300 can be used in systems with 1 to 3 sensors connected.

Fig. 23 shows an example of an installation incorporating sensors.

Fig. 23

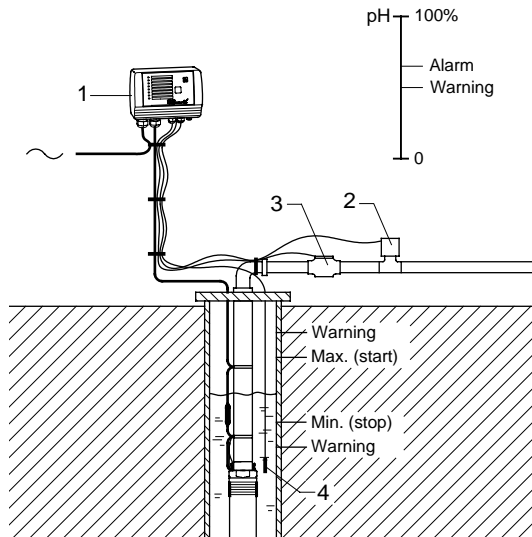

TM01 2672 2198

Pos.	Description
1	CU 300.
2	pH sensor. Detects the water quality.
3	Pulse flow meter. Detects the water quantity.
4	Level sensor.

The alarm, warning and stop limits can be set individually for all sensors connected. The limit settings do not influence each other, and each setting offers its own functioning.

Fig. 24 shows a schematic presentation of the setting of maximum and minimum limits for alarm, warning and stop respectively.

Fig. 24

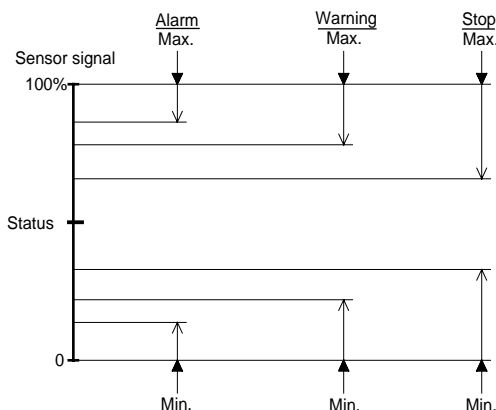

TM01 2697 2298

It is necessary to set only the limits applying to the sensor selected. Where “-” is selected, the setting is automatically “not active”.

These settings are made in the R100 displays 12.3.1 to 12.3.9.

6.2 Sensor functioning

6.2.1 Alarm limits

When an alarm limit is exceeded, the following takes place:

1. The pump is stopped.
2. The alarm signal relay operates.
3. The “Sensor alarm” indicator light on the CU 300 is on.
4. The alarm appears in the R100 display 12.1.3 Alarm.

If the pump has stopped already or if the alarm signal relay has operated, this condition is maintained.

6.2.2 Warning limits

When a warning limit is exceeded, the following takes place:

1. The alarm signal relay operates.
2. Pump operation is continued. No “Sensor alarm” indication.
3. The warning appears in the R100 display 12.1.3 Alarm.

6.2.3 Start/stop limits

Start/stop limits should be used in connection with the emptying/filling of e.g. water tanks.

The start/stop function depends on the application, i.e. emptying or filling.

- Emptying means that the pump must start at a given maximum water level and stop at a given minimum water level, see fig. 25.

Fig. 25

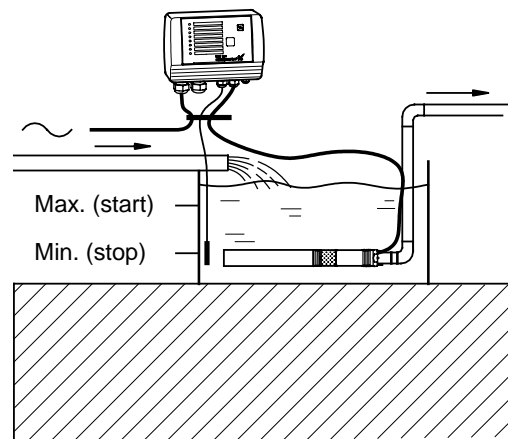

TM01 2700 2298

- Filling means that the pump must start at a given minimum water level and stop at a given maximum water level, see fig. 26.

Fig. 26

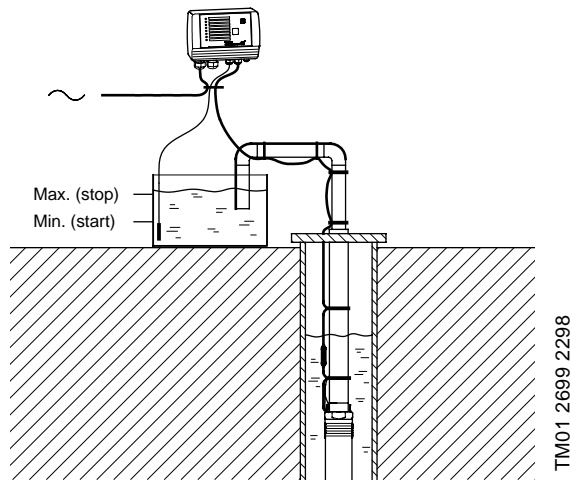

The CU 300 is supplied with a set of gaskets for the Pg screwed connections.

The gaskets are to be used for the connection of cables/wires to ensure tight connections (IP 55) and cable relief.

6.3 Installation



Before starting any work on the CU 300, make sure that the electricity supply has been switched off and that it cannot be accidentally switched on.

6.4 Location

The CU 300 can be placed both indoors and outdoors. It must not be exposed to direct sunlight.

6.5 Mounting the CU 300

The CU 300 is designed for wall mounting.

The box has six mounting holes ($\varnothing 4$), see fig. 27 (dimensions stated in mm).

The CU 300 must be mounted:

- horizontally (see fig. 27) to allow condensed water, if any, to escape.
- on a plane surface to avoid deformation of the box.

Fig. 27

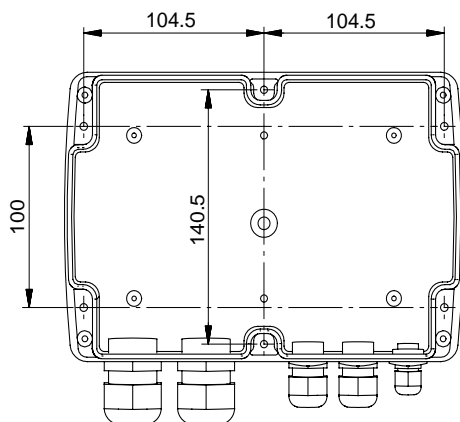

6.6 Electrical connection



Never make any connections in the CU 300 unit unless the electricity supply has been switched off. The CU 300 must be connected in accordance with the rules and standards in force for the application in question.

The supply voltage and frequency are marked on the nameplate. Make sure that the CU 300 is suitable for the electricity supply on which it will be used.

Fig. 28

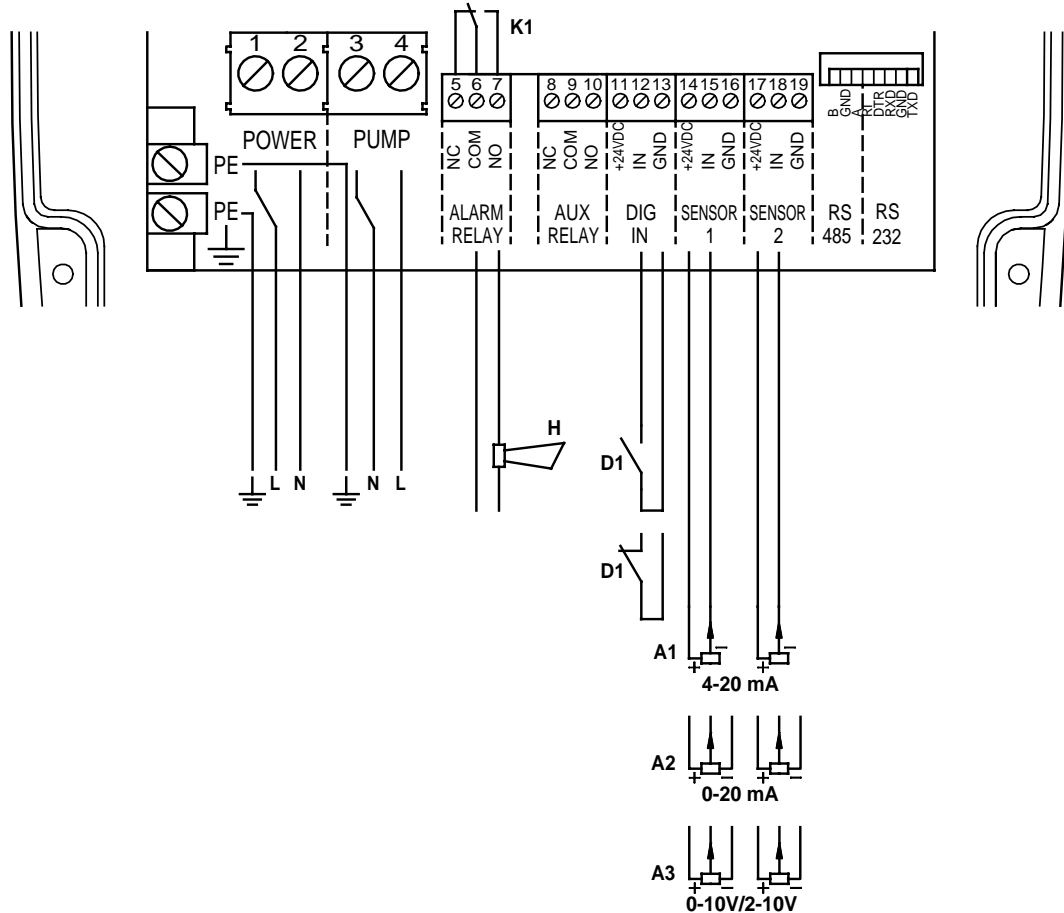

Legend:

Pos.	Description
A1	Analog sensor, output signal 4-20 mA.
A2	Analog sensor, output signal 0-20 mA.
A3	Analog sensor, output signal 0-10/2-10 V.
D1	Digital sensor, NO (normally open).
D2	Digital sensor, NC (normally closed).
H	Alarm signal transmitter (optional).
K1	Internal alarm signal relay. Relay data: 250 VAC, 8 A, AC1.

6.6.1 Mains supply

POWER, terminals 1, 2 and PE:

Connect terminals 1 and 2 to the phase and neutral leads of the mains supply. Each terminal can be connected to any of the two leads.

Connect the PE terminal to the green/yellow earth lead. Each PE terminal must be connected to an earth lead of its own.

Maximum cross-section of the leads to be connected is 6 mm².

Back-up fuse: Maximum 16 A.

Note: The leads of the mains supply must not be connected to terminals 3 and 4 (PUMP).

TM01 3088 2500

6.6.2 Pump supply

PUMP, terminals 3, 4 and PE:

Connect terminals 3 and 4 to the phase and neutral leads of the pump. Each terminal can be connected to any of the two leads.

Connect the PE terminal to the green/yellow earth lead. Each PE terminal must be connected to an earth lead of its own.

Maximum cross-section of the leads to be connected is 6 mm².

6.6.3 Alarm signal relay

ALARM RELAY, terminals 5, 6 and 7:

Connect terminals 5, 6 and 7 to the internal alarm signal relay as follows:

- Terminal 5 NC (normally closed).
- Terminal 6 COM (common).
- Terminal 7 NO (normally open).

The relay operates when the alarm and warning limits are exceeded.

Manual or automatic restarting can be selected in the R100 display *12.4.3 Automatic restart*.

Manual restarting is carried out by means of the On/Off button on the CU 300.

6.6.4 Sensors

SENSOR 1 and SENSOR 2, terminals 14, 15, 16, 17, 18 and 19:

Terminals 14, 15 and 16 (SENSOR 1) and terminals 17, 18 and 19 (SENSOR 2) are used for external sensors, e.g. a pressure gauge, a flow meter or another type of sensor.

Limits for the signal from an external sensor are set by means of the R100 in the LIMITS menu.

The signal can be used

- to start and stop the motor and
- to operate the alarm signal relay, without stopping the motor.

The sensors must give signals within the ranges 0-20 or 4-20 mA, 0-10 or 2-10 VDC. Changeover between current and voltage signals is carried out by means of the R100.

The total load of terminals 11, 14 and 17 (+24 VDC) must not exceed 100 mA.

6.7 Settings

In the following section, the relevant R100 displays and settings are shown and described.

For a detailed description of the R100 displays, see section *12. CU 300 with R100*. Each individual display has a number which refers to the section in which it is described in detail.

6.7.1 Required R100 settings

The following R100 settings must be made:

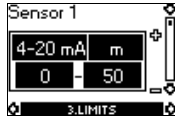
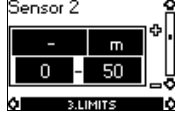
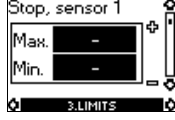
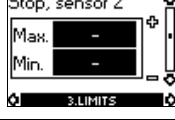
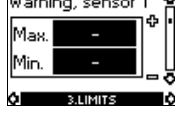
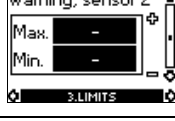
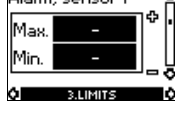
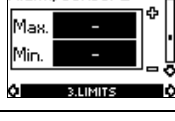
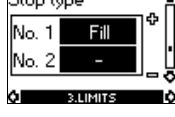
Display	R100 setting
<p>12.3.1 Sensor 1</p>  <p>12.3.5 Sensor 2</p> 	<p>Set the</p> <ul style="list-style-type: none"> • sensor output signal (4-20 mA), • setting range unit (m), and • setting range (0-50) for sensor 1 and sensor 2 respectively. <p>Sensor 2 is set to “not active”.</p>
<p>12.3.2 Stop, sensor 1</p>  <p>12.3.6 Stop, sensor 2</p> 	<p>Set the</p> <ul style="list-style-type: none"> • maximum stop limit and • minimum stop limit for sensor 1 and sensor 2 respectively.
<p>12.3.3 Warning, sensor 1</p>  <p>12.3.7 Warning, sensor 2</p> 	<p>Set the</p> <ul style="list-style-type: none"> • maximum warning limit and • minimum warning limit for sensor 1 and sensor 2 respectively.
<p>12.3.4 Alarm, sensor 1</p>  <p>12.3.8 Alarm, sensor 2</p> 	<p>Set the</p> <ul style="list-style-type: none"> • maximum alarm limit and • minimum alarm limit for sensor 1 and sensor 2 respectively.
<p>12.3.9 Stop type</p> 	<p>Set the desired stop type.</p> <p>Example:</p> <ul style="list-style-type: none"> • Sensor 1: Fill. • Sensor 2: “-” (not active).

It is necessary to set only the limits applying to the sensor selected. Where “-” is selected, the setting is automatically “not active”.

7. CU 300 connected to potentiometer

7.1 Description

Using an external potentiometer enables:

- manual control of the motor speed, and thereby of pump performance.
- manual starting/stopping of the pump.

Note: To stop the pump, turn the potentiometer (SPP 1) to "STOP".

Fig. 29 shows an example of an installation incorporating a potentiometer.

Fig. 29

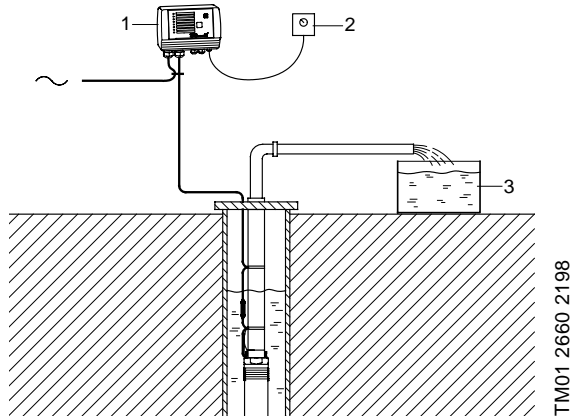

Pos.	Description
1	CU 300.
2	External GRUNDFOS potentiometer, SPP 1. The required flow is obtained by changing the motor speed manually using the external potentiometer.
3	Water tank.

7.2 Installation



Before starting any work on the CU 300, make sure that the electricity supply has been switched off and that it cannot be accidentally switched on.

7.3 Location

The CU 300 can be placed both indoors and outdoors. It must not be exposed to direct sunlight.

7.4 Mounting the CU 300

The CU 300 is designed for wall mounting.

The box has six mounting holes (ø4), see fig. 30 (dimensions stated in mm).

The CU 300 must be mounted:

- horizontally (see fig. 30) to allow condensed water, if any, to escape.
- on a plane surface to avoid deformation of the box.

Fig. 30

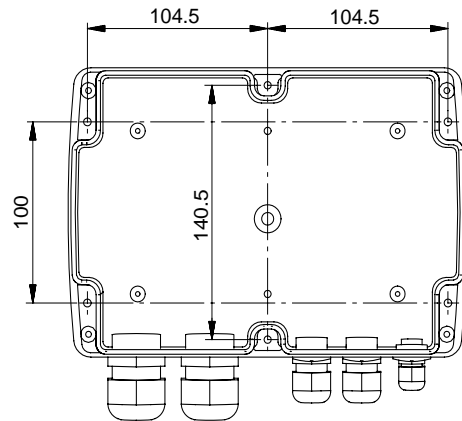

The CU 300 is supplied with a set of gaskets for the Pg screwed connections.

The gaskets are to be used for the connection of cables/wires to ensure tight connections (IP 55) and cable relief.

TM01 2824 2498

7.5 Electrical connection



Never make any connections in the CU 300 unit unless the electricity supply has been switched off. The CU 300 must be connected in accordance with the rules and standards in force for the application in question.

The supply voltage and frequency are marked on the nameplate. Make sure that the CU 300 is suitable for the electricity supply on which it will be used.

Fig. 31

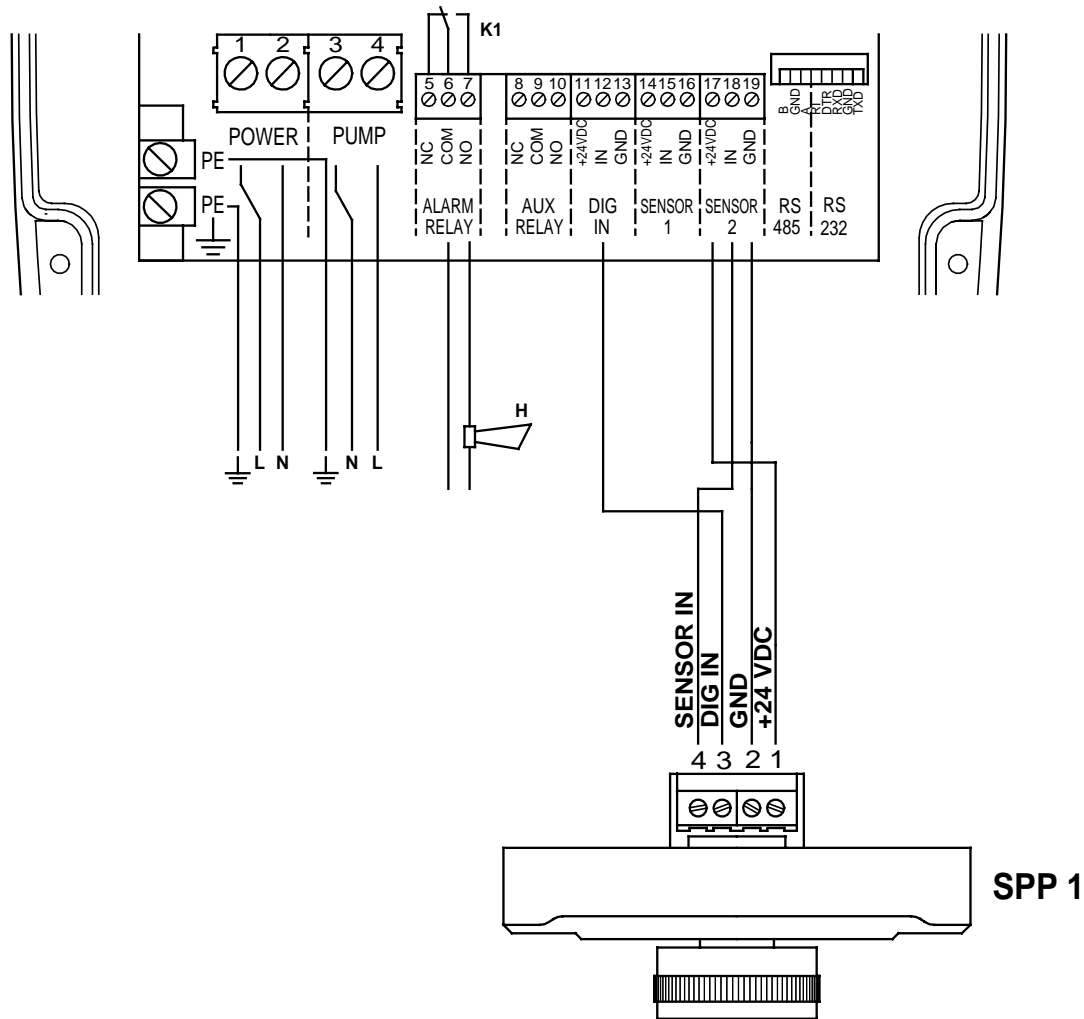

Legend:

Pos.	Description
K1	Internal alarm signal relay. Relay data: 250 VAC, 8 A, AC1.
H	Alarm signal transmitter (optional).
SPP 1	External GRUNDFOS potentiometer, SPP 1.

7.5.1 Mains supply

POWER, terminals 1, 2 and PE:

Connect terminals 1 and 2 to the phase and neutral leads of the mains supply. Each terminal can be connected to any of the two leads.

Connect the PE terminal to the green/yellow earth lead. Each PE terminal must be connected to an earth lead of its own.

Maximum cross-section of the leads to be connected is 6 mm².

Back-up fuse: Maximum 16 A.

Note: The leads of the mains supply must not be connected to terminals 3 and 4 (PUMP).

TM01 3091 3398

7.5.2 Pump supply

PUMP, terminals 3, 4 and PE:

Connect terminals 3 and 4 to the phase and neutral leads of the pump. Each terminal can be connected to any of the two leads.

Connect the PE terminal to the green/yellow earth lead. Each PE terminal must be connected to an earth lead of its own.

Maximum cross-section of the leads to be connected is 6 mm².

7.5.3 Alarm signal relay

ALARM RELAY, terminals 5, 6 and 7:

Connect terminals 5, 6 and 7 to the internal alarm signal relay as follows:

- Terminal 5 NC (normally closed).
- Terminal 6 COM (common).
- Terminal 7 NO (normally open).

The relay operates when the alarm and warning limits are exceeded.

Manual or automatic restarting can be selected in the R100 display *12.4.3 Automatic restart*.

Manual restarting is carried out by means of the On/Off button on the CU 300.

7.5.4 Potentiometer SPP 1

Connections between the SPP 1 and the CU 300:

Terminals	
SPP 1	CU 300
1	17 (SENSOR 2 +24 VDC).
2	19 (SENSOR 2 GND).
3	12 (DIG IN).
4	18 (SENSOR 2 IN).



7.6 Settings

In the following section, the relevant R100 displays and settings are shown and described.

For a detailed description of the R100 displays, see section *12. CU 300 with R100*. Each individual display has a number which refers to the section in which it is described in detail.

7.6.1 Required R100 settings

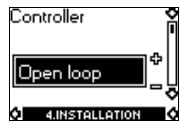
The following R100 settings must be made:

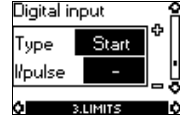
Display	R100 setting
<p><i>12.4.1 Controller</i></p> 	<p>Select "Open loop".</p> <p>Enabling of speed control.</p>
<p><i>12.4.2 External setpoint</i></p> 	<p>Set the external setpoint to "SPP 1".</p> <p>Enabling of speed control using the SPP 1. Sensor input 2 is calibrated to the signal from the SPP 1.</p> <p>The internal 24 VDC of the CU 300 is used.</p>
<p><i>12.3.10 Digital input</i></p> 	<p>Set</p> <ul style="list-style-type: none"> • Type to "Start" and • I/pulse to "-" (not active).

8. CU 300 connected to water meter

8.1 Description

Using a water meter (pulse flow meter) enables:

- monitoring of the flow,
- stop of pump after a given quantity of water has been pumped and
- indication of accumulated flow and the energy consumption required to pump 1 m³.

Fig. 32 shows an example of an irrigation system incorporating a water meter.

Fig. 32

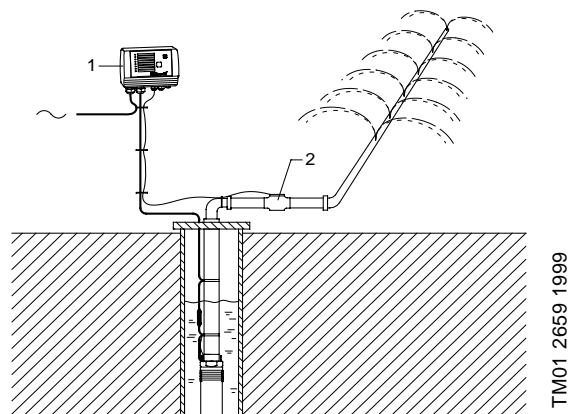

TM01 2659 1999

Pos.	Description
1	CU 300.
2	Water meter (pulse flow meter).

8.2 Installation



Before starting any work on the CU 300, make sure that the electricity supply has been switched off and that it cannot be accidentally switched on.

8.3 Location

The CU 300 can be placed both indoors and outdoors. It must not be exposed to direct sunlight.

8.4 Mounting the CU 300

The CU 300 is designed for wall mounting.

The box has six mounting holes (ø4), see fig. 33 (dimensions stated in mm).

The CU 300 must be mounted:

- horizontally (see fig. 33) to allow condensed water, if any, to escape.
- on a plane surface to avoid deformation of the box.

Fig. 33

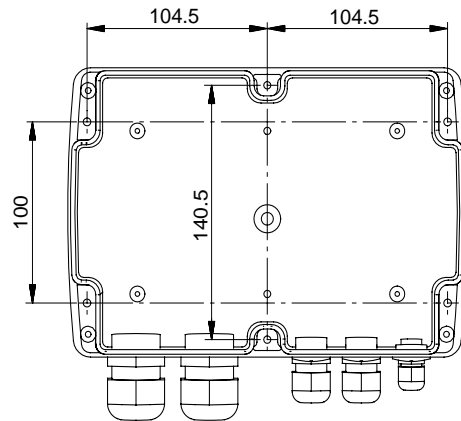

TM01 2824 2498

The CU 300 is supplied with a set of gaskets for the Pg screwed connections.

The gaskets are to be used for the connection of cables/wires to ensure tight connections (IP 55) and cable relief.

8.5 Electrical connection



Never make any connections in the CU 300 unit unless the electricity supply has been switched off. The CU 300 must be connected in accordance with the rules and standards in force for the application in question.

The supply voltage and frequency are marked on the nameplate. Make sure that the CU 300 is suitable for the electricity supply on which it will be used.

Fig. 34

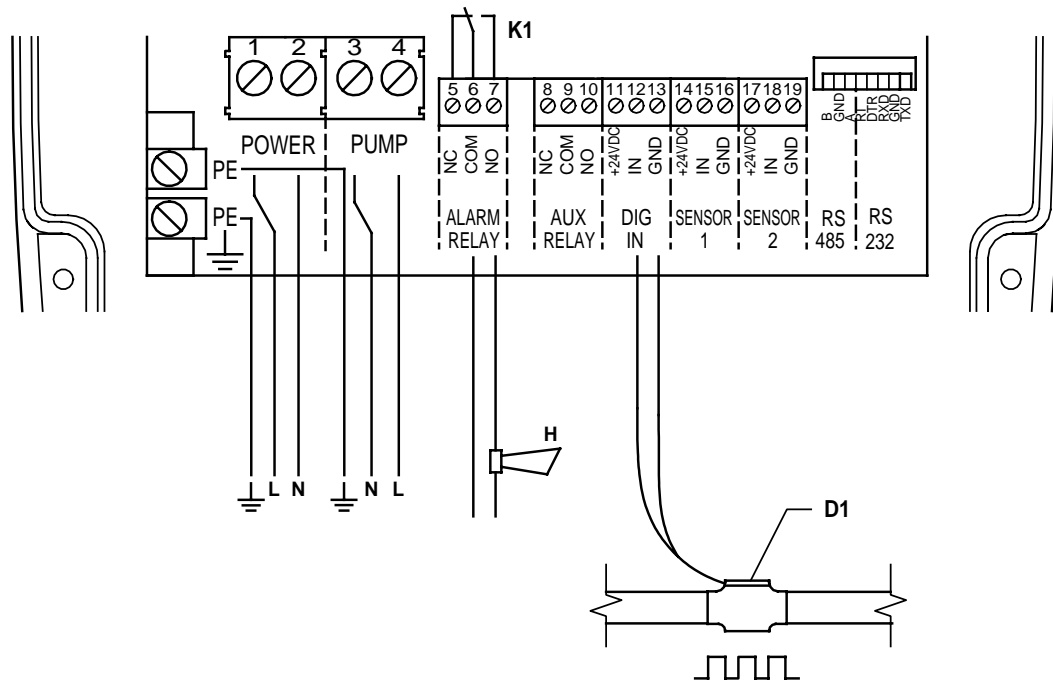

Legend:

Pos.	Description
D1	Water meter (pulse flow meter).
H	Alarm signal transmitter (optional).
K1	Internal alarm signal relay. Relay data: 250 VAC, 8 A, AC1.

8.5.1 Mains supply

POWER, terminals 1, 2 and PE:

Connect terminals 1 and 2 to the phase and neutral leads of the mains supply. Each terminal can be connected to any of the two leads.

Connect the PE terminal to the green/yellow earth lead. Each PE terminal must be connected to an earth lead of its own.

Maximum cross-section of the leads to be connected is 6 mm².

Back-up fuse: Maximum 16 A.

Note: The leads of the mains supply must not be connected to terminals 3 and 4 (PUMP).

8.5.2 Pump supply

PUMP, terminals 3, 4 and PE:

Connect terminals 3 and 4 to the phase and neutral leads of the pump. Each terminal can be connected to any of the two leads.

Connect the PE terminal to the green/yellow earth lead. Each PE terminal must be connected to an earth lead of its own.

Maximum cross-section of the leads to be connected is 6 mm².

8.5.3 Alarm signal relay

ALARM RELAY, terminals 5, 6 and 7:

Connect terminals 5, 6 and 7 to the internal alarm signal relay as follows:

- Terminal 5 NC (normally closed).
- Terminal 6 COM (common).
- Terminal 7 NO (normally open).

The relay operates when the alarm and warning limits are exceeded.

Manual or automatic restarting can be selected in the R100 display *12.4.3 Automatic restart*.

Manual restarting is carried out by means of the On/Off button on the CU 300.

8.5.4 Water meter (pulse flow meter)

DIG IN, terminals 12 and 13:

Connect terminals 12 and 13 to the water meter:

- Terminal 12 IN (signal input).
- Terminal 13 GND (earth).

8.6 Settings

In the following section, the relevant R100 displays and settings are shown and described.

For a detailed description of the R100 displays, see section 12. *CU 300 with R100*. Each individual display has a number which refers to the section in which it is described in detail.

8.6.1 Required R100 settings

The following R100 settings must be made:

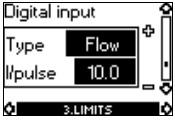
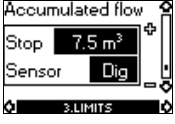
Display	R100 setting
<p>12.3.10 Digital input</p> 	<p>Set</p> <ul style="list-style-type: none"> • Type to “Flow” and • l/pulse to <p>Example: “10 l/pulse”.</p> <p>When a value has been set in this display, the actual flow will appear in display 12.2.8 <i>Digital input</i>.</p>
<p>12.3.11 Accumulated flow</p> 	<p>A value should only be set in this display if the following is required:</p> <ul style="list-style-type: none"> • stop of pump after a given quantity of water has been pumped. <p>Set</p> <ul style="list-style-type: none"> • Stop to the desired flow. <p>Example:</p> <ul style="list-style-type: none"> • Stop: “7.5 m³”. • Sensor: “Dig”. <p>When a value has been set in this display, the “Accumulated flow” and “Energy per m³” will appear in display 12.2.9 <i>Accumulated flow and energy per m³</i>.</p>

9. Constant water level

9.1 Description

The water level can be kept constant by connecting an analog level sensor.

Fig. 35 shows an example of an installation designed for maintaining a constant water level in the bore-hole.

Fig. 35

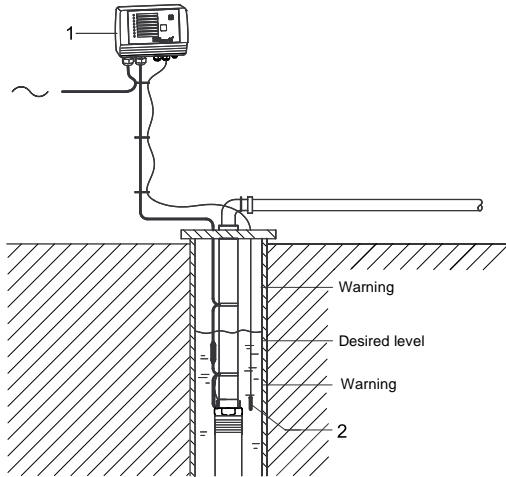

TM01 2671 2400

Pos.	Description
1	CU 300.
2	Water meter (analog flow meter).
3	Level sensor.

9.2 Function

The CU 300 controls the pump speed and consequently adjusts the pump performance to the bore-hole yield.

1. When the water level is much higher than the desired level (setpoint), the pump is running at maximum performance.
2. When the level is coming closer to the desired level, the pump performance will be reduced.
3. When the desired level is reached, the pump speed will be so low that the pump performance is zero. After further 60 seconds, the pump will stop.

9.3 Installation



Before starting any work on the CU 300, make sure that the electricity supply has been switched off and that it cannot be accidentally switched on.

9.4 Location

The CU 300 can be placed both indoors and outdoors. It must not be exposed to direct sunlight.

9.5 Mounting the CU 300

The CU 300 is designed for wall mounting.

The box has six mounting holes (ø4), see fig. 36 (dimensions stated in mm).

The CU 300 must be mounted:

- horizontally (see fig. 36) to allow condensed water, if any, to escape.
- on a plane surface to avoid deformation of the box.

Fig. 36

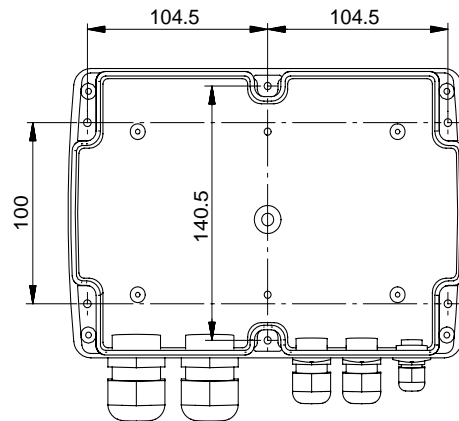

TM01 2824 2498

The CU 300 is supplied with a set of gaskets for the Pg screwed connections.

The gaskets are to be used for the connection of cables/wires to ensure tight connections (IP 55) and cable relief.

9.6 Electrical connection



Never make any connections in the CU 300 unit unless the electricity supply has been switched off. The CU 300 must be connected in accordance with the rules and standards in force for the application in question.

The supply voltage and frequency are marked on the nameplate. Make sure that the CU 300 is suitable for the electricity supply on which it will be used.

Fig. 37

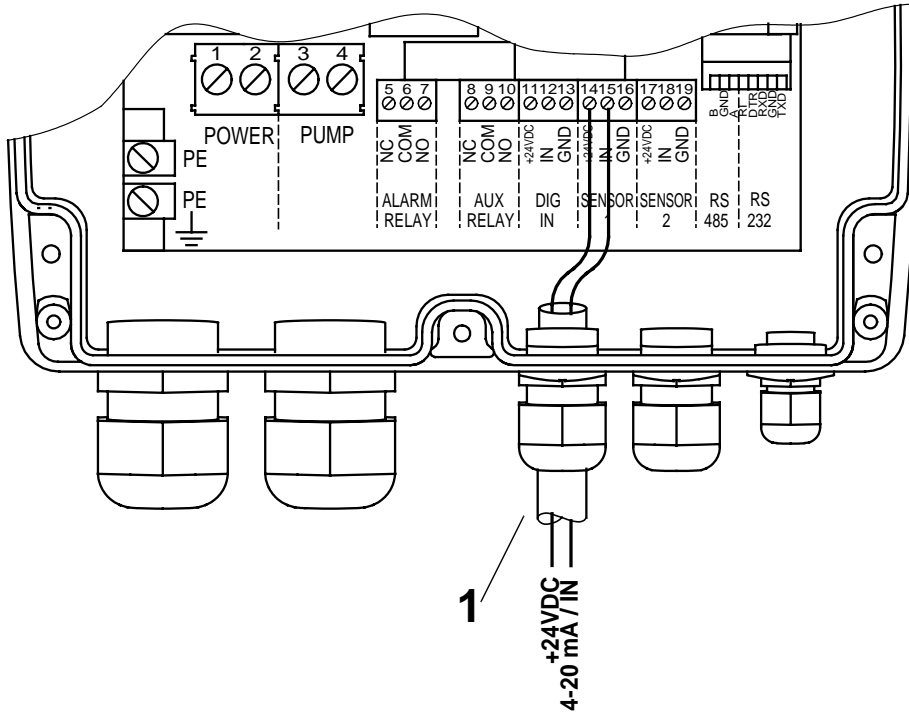

TM01 6213 2400

Legend:

Pos.	Description
1	Connection of level sensor: <ul style="list-style-type: none"> Terminal 14, 24 VDC supply. Terminal 15, signal input.

9.6.1 Mains supply

POWER, terminals 1, 2 and PE:

Connect terminals 1 and 2 to the phase and neutral leads of the mains supply. Each terminal can be connected to any of the two leads.

Connect the PE terminal to the green/yellow earth lead. Each PE terminal must be connected to an earth lead of its own.

Maximum cross-section of the leads to be connected is 6 mm².

Back-up fuse: Maximum 16 A.

Note: The leads of the mains supply must not be connected to terminals 3 and 4 (PUMP).

9.6.2 Pump supply

PUMP, terminals 3, 4 and PE:

Connect terminals 3 and 4 to the phase and neutral leads of the pump. Each terminal can be connected to any of the two leads.

Connect the PE terminal to the green/yellow earth lead. Each PE terminal must be connected to an earth lead of its own.

Maximum cross-section of the leads to be connected is 6 mm².

9.6.3 Alarm signal relay

ALARM RELAY, terminals 5, 6 and 7:

Connect terminals 5, 6 and 7 to the internal alarm signal relay as follows:

- Terminal 5 NC (normally closed).
- Terminal 6 COM (common).
- Terminal 7 NO (normally open).

The relay operates when the alarm and warning limits are exceeded.

Manual or automatic restarting can be selected in the R100 display *12.4.3 Automatic restart*.

Manual restarting is carried out by means of the On/Off button on the CU 300.

9.6.4 Level sensor

Connect terminals 14 and 15 to the level sensor:

- Terminal 14, 24 VDC (voltage supply).
- Terminal 15, IN (signal input).

9.7 Settings

In the following section, the relevant R100 displays and settings are shown and described.

For a detailed description of the R100 displays, see section *12. CU 300 with R100*. Each individual display has a number which refers to the section in which it is described in detail.

9.7.1 Required R100 settings

The following R100 settings must be made:

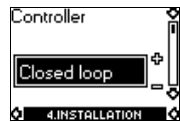
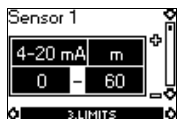
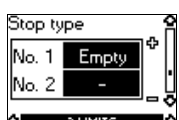
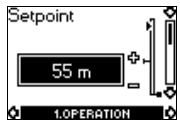
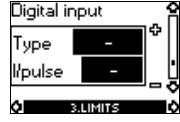
Display	R100 setting
<p><i>12.4.1 Controller</i></p> 	Select "Closed loop".
<p><i>12.3.1 Sensor 1</i></p> 	Set the sensor type. Example: <ul style="list-style-type: none"> • Sensor output signal (4-20 mA), • setting range unit (m), • setting range (0-60 m).
<p><i>12.3.9 Stop type</i></p> 	Set the stop type. <ul style="list-style-type: none"> • Sensor 1: "Empty". • Sensor 2: "-" (not active).
<p><i>12.1.1 Setpoint</i></p> 	Set the desired water level (m). Example: 55 m. Rule: The maximum setting of the setpoint corresponds to the maximum value set in display <i>12.3.1 Sensor 1</i> less 5 m. In this case, 60 less 5 = 55 m. The water level can be kept within a tolerance of $\pm 1\%$ of the setting range.
<p><i>12.3.10 Digital input</i></p> 	Set <ul style="list-style-type: none"> • Type to "-" (not active) and • I/pulse to "-" (not active).

10. CU 300 connected to RS-232, RS-485

10.1 Description

Using the RS-232 input enables:

- communication over long distances via modem,
- direct connection of a PC.

Using the RS-485 input enables:

- communication via GRUNDFOS field bus GENI-bus,
- connection to the GRUNDFOS G100 gateway for communication over long distances, e.g. via radio.

10.2 CU 300 connected to a PC directly

Fig. 38 shows an example of an installation which is connected to a PC directly via the RS-232 input.

The installation shown in the example, fig. 38, enables:

- configuration,
- fault finding,
- servicing

of the installation by means of a PC with PC Tool CU 300 software.

Fig. 38

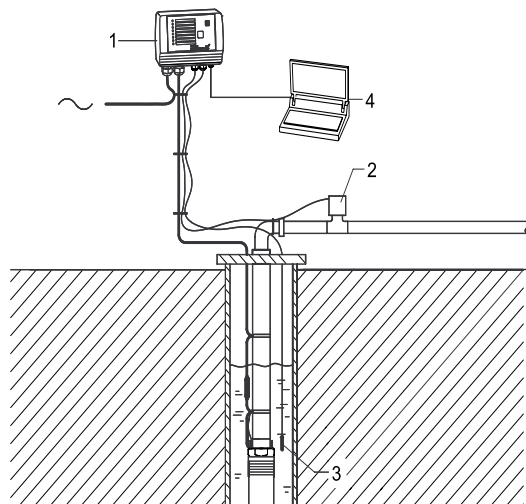

Pos.	Description
1	CU 300.
2	E.g. a pH sensor for monitoring of water quality.
3	Level sensor.
4	PC.

CU 300 with modem connection to PC:

Fig. 39 shows an example of an installation connected to a modem with telephone connection to modem/PC via the RS-232 input.

The installation shown in the example, fig. 39, enables:

- configuration,
 - fault finding,
 - servicing
- of the installation over long distances.

Fig. 39

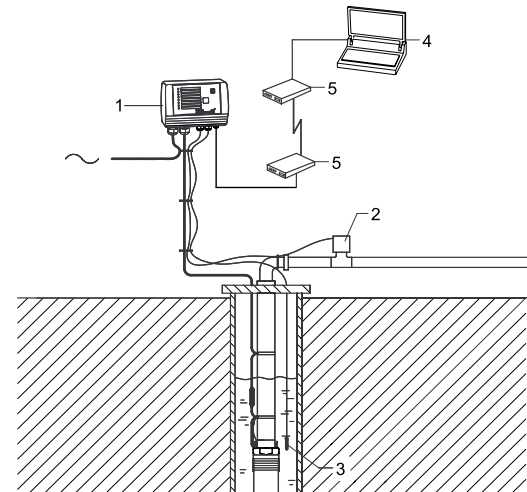

Pos.	Description
1	CU 300.
2	E.g. a pH sensor for monitoring of water quality.
3	Level sensor.
4	PC.
5	Modem.

CU 300 connected to GENibus network:

Fig. 40 shows an example of an installation connected to a GENibus network with two CU 300 installations via the RS-485 input. The GENibus network is connected to a G100 gateway with radio connection to a PC.

The installation shown in the example, fig. 40, enables:

- configuration,
- fault finding,
- servicing,
- data logging

of the connected installations over long distances.

It is possible to connect and communicate with up to 32 GENibus units on one network.

The units can be

- CU 300 units only or
- CU 300 units in combination with other GRUNDFOS products with GENibus connection to for instance a CU 3.

Contact GRUNDFOS for further details.

Fig. 40

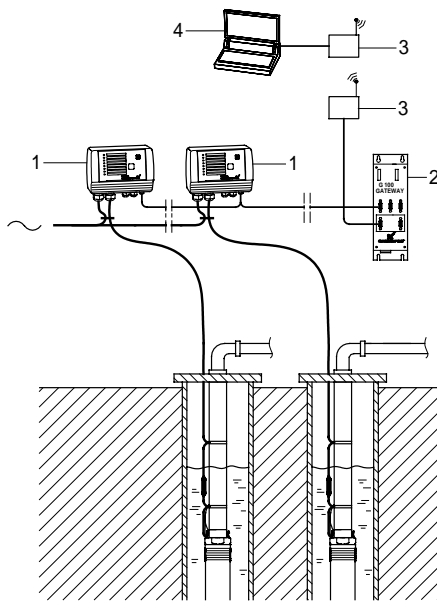

TM01 6371 2199

Pos.	Description
1	CU 300.
2	G100 gateway.
3	Radio.
4	PC.

10.3 Installation



Before starting any work on the CU 300, make sure that the electricity supply has been switched off and that it cannot be accidentally switched on.

10.4 Location

The CU 300 can be placed both indoors and outdoors. It must not be exposed to direct sunlight.

10.5 Mounting the CU 300

The CU 300 is designed for wall mounting.

The box has six mounting holes (ø4), see fig. 41 (dimensions stated in mm).

The CU 300 must be mounted:

- horizontally (see fig. 41) to allow condensed water, if any, to escape.
- on a plane surface to avoid deformation of the box.

Fig. 41

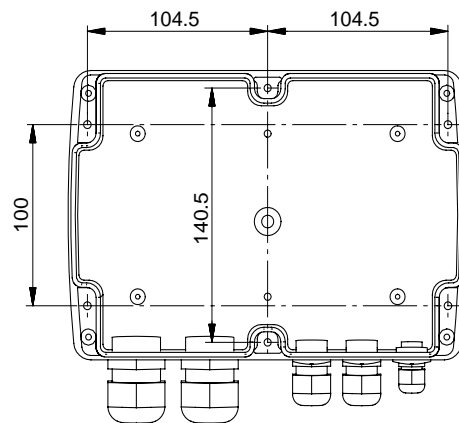

TM01 2824 2498

The CU 300 is supplied with a set of gaskets for the Pg screwed connections.

The gaskets are to be used for the connection of cables/wires to ensure tight connections (IP 55) and cable relief.

10.6 Electrical connection



Never make any connections in the CU 300 unit unless the electricity supply has been switched off. The CU 300 must be connected in accordance with the rules and standards in force for the application in question.

The supply voltage and frequency are marked on the nameplate. Make sure that the CU 300 is suitable for the electricity supply on which it will be used.

Fig. 42

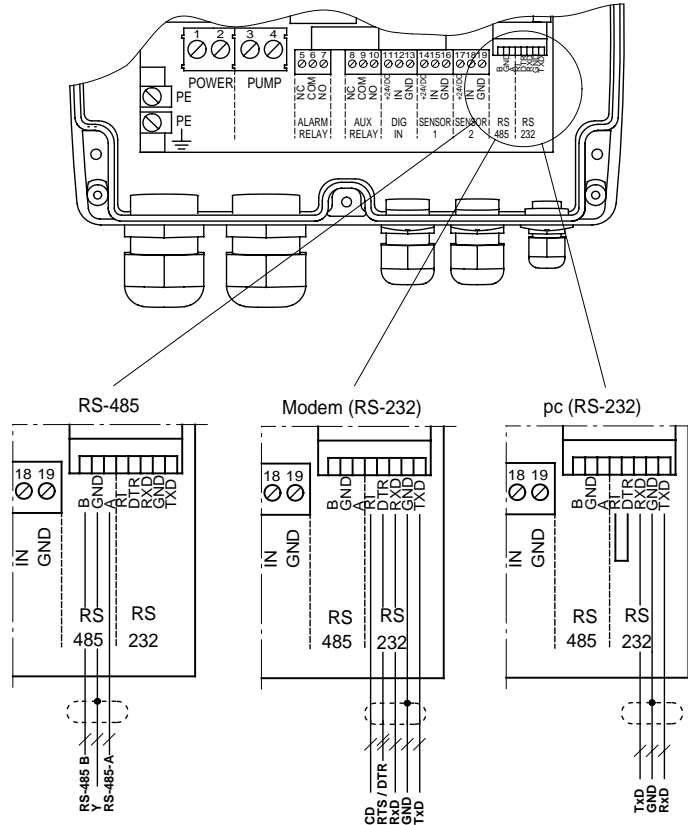

Legend:

Pos.	Description
RS-485	Connection of RS-485, GENIbus.
Modem (RS-232)	Connection of modem to RS-232.
PC (RS-232)	Connection of PC to RS-232.

10.6.1 Mains supply

POWER, terminals 1, 2 and PE:

Connect terminals 1 and 2 to the phase and neutral leads of the mains supply. Each terminal can be connected to any of the two leads. Connect the PE terminal to the green/yellow earth lead. Each PE terminal must be connected to an earth lead of its own.

Maximum cross-section of the leads to be connected is 6 mm².

Back-up fuse: Maximum 16 A.

Note: The leads of the mains supply must not be connected to terminals 3 and 4 (PUMP).

10.6.2 Pump supply

PUMP, terminals 3, 4 and PE:

Connect terminals 3 and 4 to the phase and neutral leads of the pump. Each terminal can be connected to any of the two leads.

Connect the PE terminal to the green/yellow earth lead. Each PE terminal must be connected to an earth lead of its own.

Maximum cross-section of the leads to be connected is 6 mm².

TM01 6244 1999

10.6.3 Alarm signal relay

ALARM RELAY, terminals 5, 6 and 7:

Connect terminals 5, 6 and 7 to the internal alarm signal relay as follows:

- Terminal 5 NC (normally closed).
- Terminal 6 COM (common).
- Terminal 7 NO (normally open).

The relay operates when the alarm and warning limits are exceeded.

Manual or automatic restarting can be selected in the R100 display *12.4.3 Automatic restart*.

Manual restarting is carried out by means of the On/Off button on the CU 300.

10.6.4 RS-485 input

The RS-485 input, terminals A, Y (GND) and B, is for external BUS communication.

The communication is effected according to the GRUNDFOS BUS protocol, GENIbus, and is two-way communication.

The CU 300 can communicate with a PC with the PC Tool CU 300 installed.

An RS-232/RS-485 adaptor is supplied with the PC Tool CU 300. Connect the adaptor to the CU 300, terminals A, Y (GND) and B, for direct communication with a PC on a GENIbus network.

The PC Tool CU 300 enables configuration, monitoring and fault finding of the actual installation.

The RS-485 input is a low-voltage circuit. Therefore, all connections to terminals A, Y (GND) and B must be separated from network circuits by means of double or reinforced insulation.

A screened, twisted-pair cable is required.

The maximum cable length is 1200 m.

10.6.5 RS-232 input

The RS-232 input, terminals RI, DTR, RXD, GND and TXD, is a communication input.

The communication is effected according to the GRUNDFOS BUS protocol, GENIbus, and is two-way communication.

The CU 300 can communicate with a PC with the PC Tool CU 300 installed.

The PC Tool CU 300 enables configuration, monitoring and fault finding of the actual installation.

The RS-232 input is a low-voltage circuit. Therefore, all connections to terminals RI, DTR, RXD, GND and TXD must be separated from network circuits by means of double or reinforced insulation.

A screened, twisted-pair cable is required.

The maximum cable length is 20 m.

10.6.6 Modem

Connect the modem to the RS-232 input as follows:

CU 300 terminals	Modem connection
RI	CD
DTR	DTR and RTS
RXD	RXD
GND	GND
TXD	TXD

When connected to a modem, the CU 300 enables communication over long distances. In a service situation, the service engineer will be able to diagnose faults and, if required, correct them at a distance.

10.6.7 PC Tool CU 300

The PC Tool CU 300 is Windows95/NT-based software, see the PC Tool CU 300 opening display in fig. 43.

Fig. 43

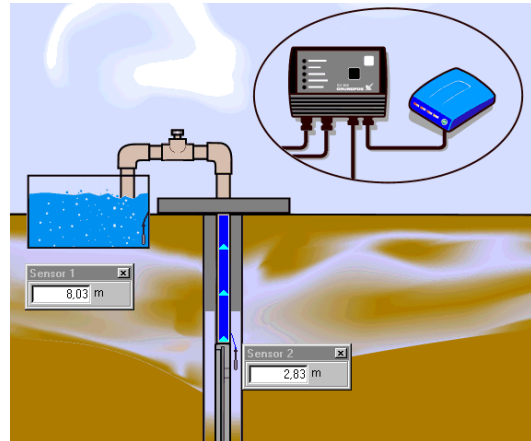

TM01 6374 2199

The PC Tool CU 300 is user-oriented with a graphic user interface with pop-ups.

The PC Tool CU 300 is an all-round PC tool which enables any kind of communication with the CU 300 and the SQE:

Subject	Description
Installation	Programming of the CU 300 and the SQE pump.
Operation	Monitoring and operation of CU 300-based SQE pumping systems.
Service	Fault finding and fault correction in CU 300-based SQE pumping systems.

The PC Tool CU 300 can be used in connection with communication via:

- RS-232 with modem connection.
- RS-232 without modem connection.
- GENIbus (RS-485) directly.
- GENIbus (RS-485) with G100 to network.

11. Alarm functions

The alarm functions indicated by the eight red indicator lights on the CU 300 are described in the following sections.

11.1 No contact

The connection and/or communication between the CU 300 and the motor is not established.

No contact is permanently on, see fig. 44.

Fig. 44

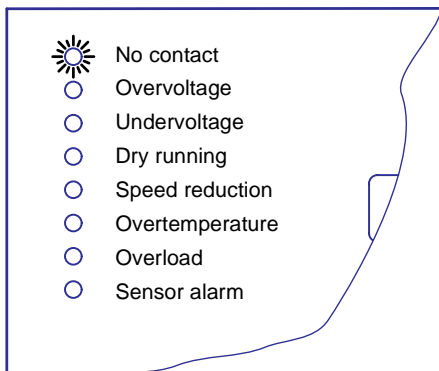

TM01 2782 2398

Possible cause	Remedy
Motor is not an MSE 3 motor.	Install an MSE 3 motor.
Motor is not connected.	Check connections.
Cable breakage.	Check cable.
Poor/no connection.	Check connections.
The cable length exceeds 200 m.	Reduce the cable length.
The CU 300 is defective.	Replace the CU 300.
Motor is defective.	Replace motor.

Important:

The alarm indication “No contact” will also appear if the pump and the CU 300 do not have the same number (allocated by the R100). The problem may occur e.g. in connection with replacing a motor or a CU 300.

Solution: The pump and the CU 300 must be allocated the same number via the R100 display 12.4.10 *Number*.

The alarm “No contact” makes the On/Off button on the CU 300 inactive, and actual operating parameters cannot be called up. However, installation parameters can be called up.

“No contact” does not cause a pump stop.

11.2 Overvoltage

The supply voltage to the motor exceeds the maximum value allowed.

Factory setting, see section 13. *Technical data*.

The motor is stopped and **Overvoltage** is permanently on, see fig. 45.

Fig. 45

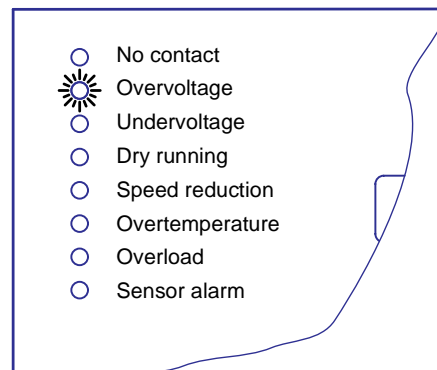

TM01 2783 2398

Possible cause	Remedy
Unstable electricity supply.	Contact the electricity supply authorities.
Too high supply voltage.	Contact the electricity supply authorities. Check installation.
Supply voltage outside voltage range of motor.	Check installation.

Restarting:

When the supply voltage lies within the voltage range of the motor, the motor will restart automatically.

11.3 Undervoltage

The supply voltage to the motor is lower than the minimum value allowed.

Factory setting, see section 13. *Technical data*.

The motor is stopped and **Undervoltage** is permanently on, see fig. 46.

Fig. 46

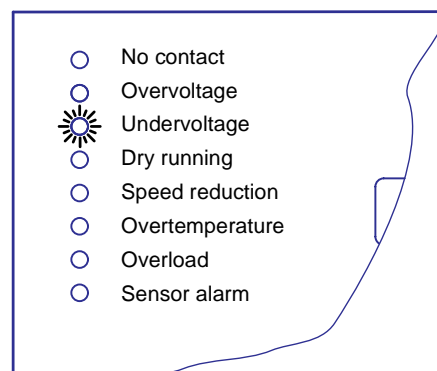

TM01 2784 2398

Possible cause	Remedy
Unstable electricity supply.	Contact the electricity supply authorities.
Supply voltage outside voltage range of motor.	Check installation.
Voltage drop in mains is too big.	Increase wire cross-section.

Restarting:

When the supply voltage lies within the voltage range of the motor, the motor will restart automatically.

11.4 Dry running

The purpose of the dry-running protection is to protect the pump in case of insufficient water flow.

The dry-running protection makes the conventional dry-running protection unnecessary.

No additional cables to the motor are required.

The dry-running alarm is activated when the load has been below the dry-running power limit for an accumulated time of 5 seconds.

The motor is stopped and **Dry running** is permanently on, see fig. 47.

Fig. 47

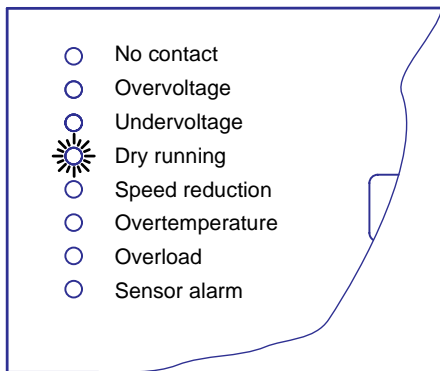

TM01 2785 2398

Possible cause	Remedy
The pump performance is too high compared to the borehole yield.	Replace the pump with a smaller one.
	Reduce pump performance using the R100 display 12.4.8 <i>Maximum speed</i> .
Borehole filter is blocked.	Borehole service is required.

Restarting:

After 5 minutes (factory setting), or the period set by means of the R100 display 12.4.3 *Automatic restart*, the motor will restart automatically.

11.5 Speed reduction

At a moderate undervoltage or overload of the motor, the speed is reduced, but the motor is not stopped. The speed reduction indicator light is on, and at the same time the undervoltage or overload light is on.

Speed reduction and **Undervoltage** or **Overload** are permanently on.

In fig. 48, the "Speed reduction" alarm was caused by undervoltage.

Fig. 48

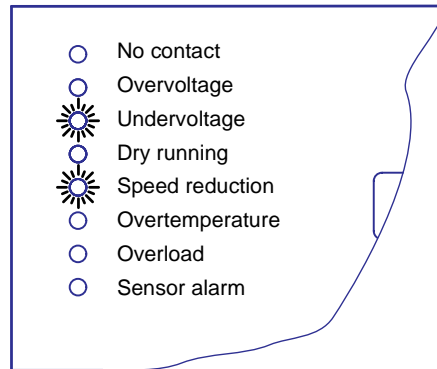

TM01 2786 2398

Possible cause	Remedy
Pump is worn, causing overload.	Pump must be serviced.
Wrong combination of pump and motor, causing overload.	Replace pump or motor.
Unstable electricity supply, causing undervoltage.	Contact the electricity supply authorities.
Too big voltage drop over the cable, causing undervoltage.	Size cable to avoid too big voltage drop.

Speed resuming:

When the supply voltage lies within the voltage range of the motor again and the cause of the overload has disappeared, the motor resumes normal speed.

11.6 Overtemperature

The motor temperature is monitored continuously during operation.

The motor is factory-set to a maximum value, see section 13. *Technical data*.

The motor temperature has exceeded the maximum temperature limit. If the temperature is too high, there is a risk that the motor electronics will be damaged.

The motor is stopped and **Overtemperature** is permanently on, see fig. 49.

Fig. 49

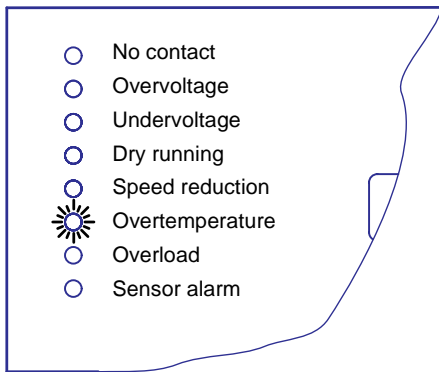

TM01 2787 2398

A too high operating temperature may indicate that the installation needs service.

Possible cause	Remedy
Insufficient cooling/flow velocity along motor.	Take out pump and install flow sleeve.
Insufficient cooling due to incrustation of the motor.	Clean motor. Install flow sleeve.

Restarting:

When the motor electronics has cooled sufficiently, the motor will restart automatically, see section 13. *Technical data*.

11.7 Overload

The motor is overloaded, i.e. the current consumption of the motor exceeds the limit value. Factory setting, see section 13. *Technical data*.

The motor is stopped and **Overload** is permanently on, see fig. 50.

Fig. 50

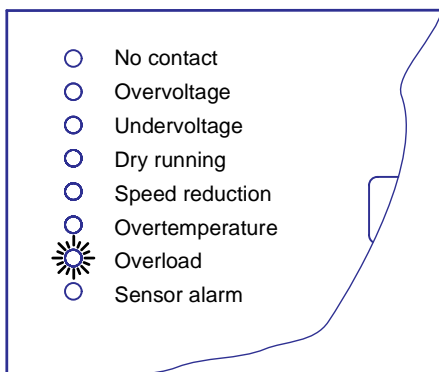

TM01 2788 2398

Possible cause	Remedy
Pump is defective.	Pump must be serviced.
Sand or gravel in pump.	Pump must be serviced.
Wrong combination of pump and motor.	Replace pump or motor.

Restarting:

After 5 minutes (factory setting), or the period set by means of the R100 display 12.4.3 *Automatic restart*, the motor will restart automatically.

11.8 Sensor alarm

This alarm means that:

- a connected sensor has detected that an alarm limit has been exceeded or
- the sensor signal has fallen outside the measuring range set.

The motor is stopped and **Sensor alarm** is permanently on, see fig. 51.

Fig. 51

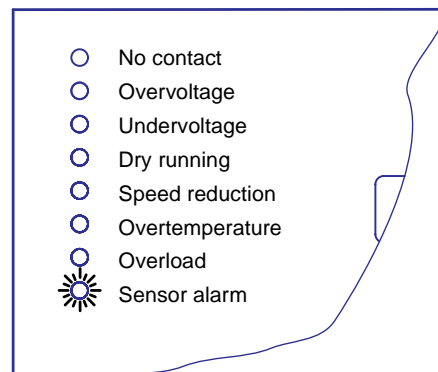

TM01 2789 2398

Restarting:

After 5 minutes (factory setting), or the period set by means of the R100 display 12.4.3 *Automatic restart*, the motor will restart automatically.

12. CU 300 with R100

The remote control R100 is used for wireless communication with the CU 300. The R100 communicates via infra-red light. During communication, there must be visual contact between the CU 300 and the R100, see fig. 52.

Fig. 52

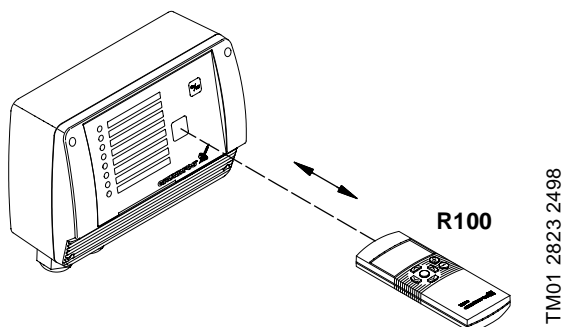

The R100 offers possibilities of setting and status displays for the CU 300.

When the communication between the R100 and CU 300 has been established, the red indicator light in the On/Off button will flash.

For general use of the R100, see the operating instructions for this unit.

The menu structure for the R100 and CU 300 is divided into five parallel menus, each including a number of displays.

0. GENERAL, see operating instructions for the R100.

1. OPERATION

2. STATUS

3. LIMITS

4. INSTALLATION

Overview of menus, see fig. 53, page 44.

Note: The number stated at each individual display in fig. 53 refers to the section in which the display is described.

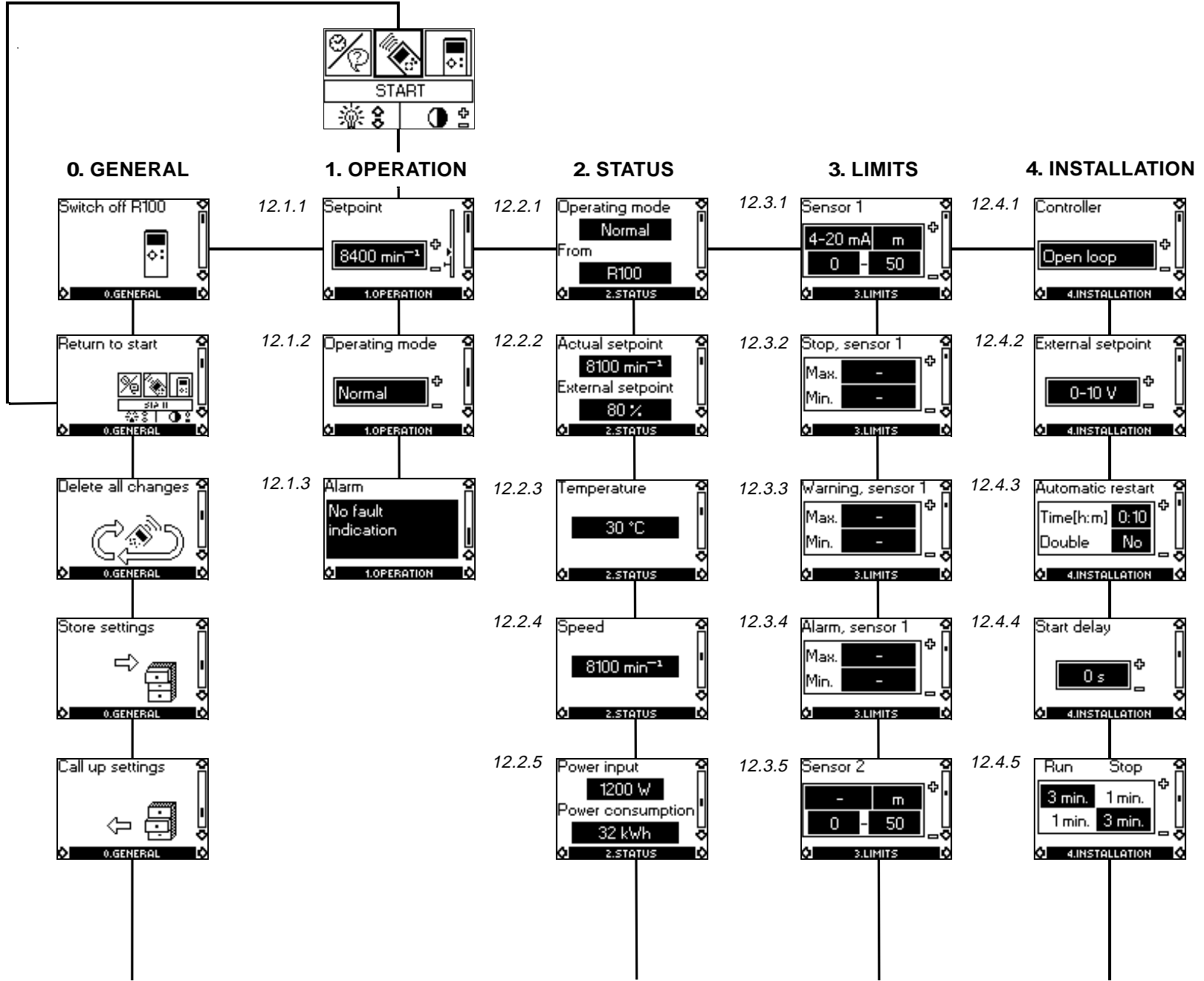
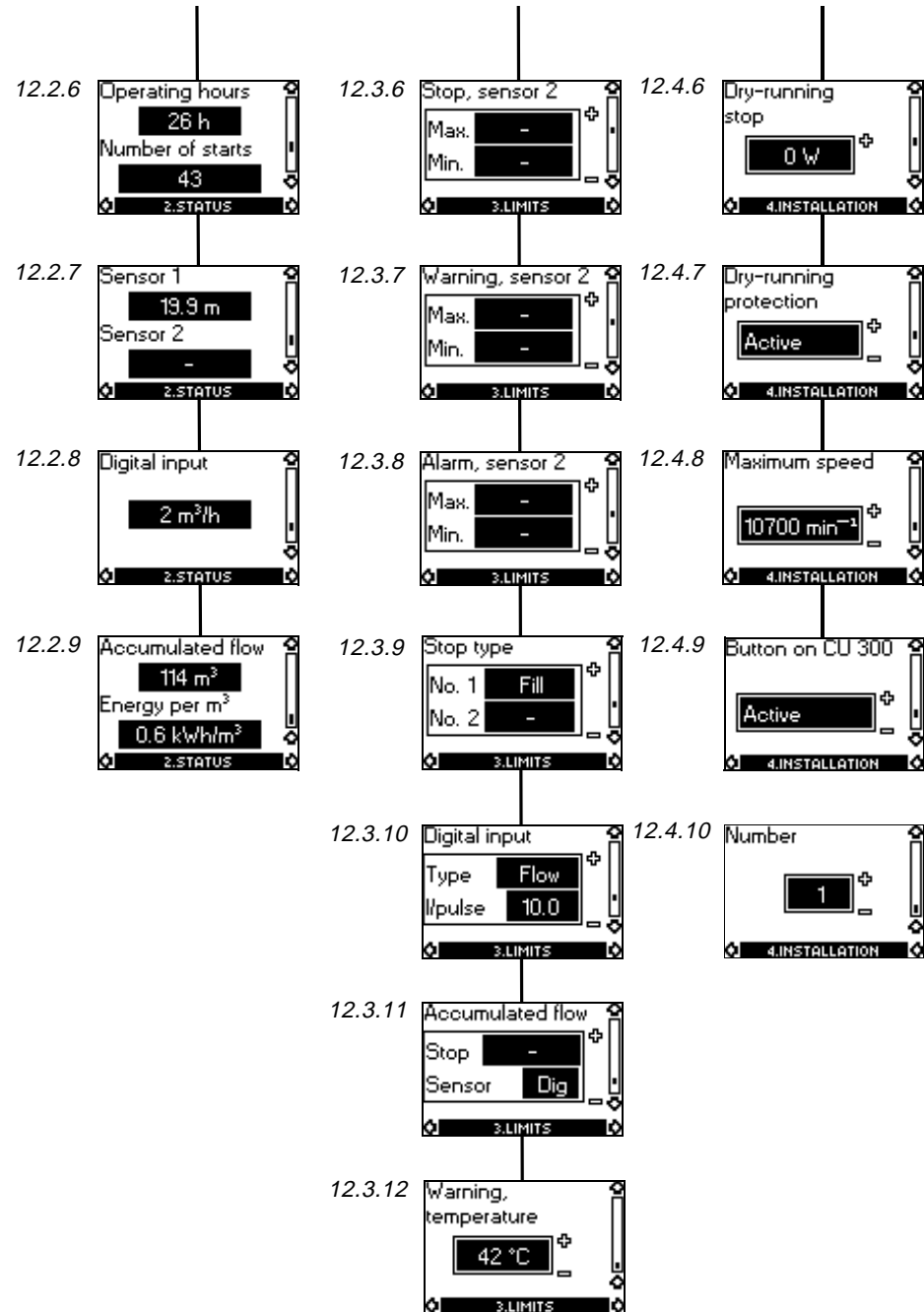
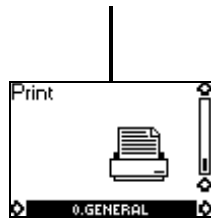

Fig. 53



Note:
This menu is an example,
not the factory setting

Factory setting of R100 values

Menu OPERATION		
Display	Factory setting	Value stored in
12.1.1 <i>Setpoint</i>	10,700 min ⁻¹	CU 300
12.1.2 <i>Operating mode</i>	Stop	CU 300
Menu LIMITS		
Display	Factory setting	Value stored in
12.3.1 <i>Sensor 1</i>	Sensor output signal: – Unit: m Min.: 0 Max.: 1	CU 300
12.3.2 <i>Stop, sensor 1</i>	Max.: – Min.: –	CU 300
12.3.3 <i>Warning, sensor 1</i>	Max.: – Min.: –	CU 300
12.3.4 <i>Alarm, sensor 1</i>	Max.: – Min.: –	CU 300
12.3.5 <i>Sensor 2</i>	Sensor output signal: – Unit: m Min.: 0 Max.: 1	CU 300
12.3.6 <i>Stop, sensor 2</i>	Max.: – Min.: –	CU 300
12.3.7 <i>Warning, sensor 2</i>	Max.: – Min.: –	CU 300
12.3.8 <i>Alarm, sensor 2</i>	Max.: – Min.: –	CU 300
12.3.9 <i>Stop type</i>	No. 1: – No. 2: –	CU 300
12.3.10 <i>Digital input</i>	Type: – I/pulse: –	CU 300
12.3.11 <i>Accumulated flow</i>	Stop: – Sensor: –	CU 300
12.3.12 <i>Warning, temperature</i>	–	CU 300
Menu INSTALLATION		
Display	Factory setting	Value stored in
12.4.1 <i>Controller</i>	Open loop	CU 300
12.4.2 <i>External setpoint</i>	–	CU 300
12.4.3 <i>Automatic restart</i>	Time: 0:05 Double: No	Motor
12.4.4 <i>Start delay</i>	0 s	CU 300
12.4.5 <i>Run/Stop</i>	Run: – Stop:–	Motor
12.4.6 <i>Dry-running stop</i>	<ul style="list-style-type: none"> • Motor type 0.1 to 0.63 kW, dry-running stop = 300 W. • Motor type 0.7 to 1.05 kW, dry-running stop = 680 W. • Motor type 1.1 to 1.73 kW, dry-running stop = 800 W. 	Motor
12.4.7 <i>Dry-running protection</i>	Active	Motor
12.4.8 <i>Maximum speed</i>	10,700 min ⁻¹	Motor
12.4.9 <i>Button on CU 300</i>	Active	CU 300
12.4.10 <i>Number</i>	–	CU 300 and motor

12.1 Menu OPERATION

The OPERATION menu for the CU 300 offers the possibility of setting and reading operating parameters.

Factory settings are marked in **bold-faced** type under each individual display. See also table on page 46.

12.1.1 Setpoint



TM Sq1_01 GB

Set the required setpoint.

- ▶ Setpoint set.
- Actual setpoint.

Setting range: **7,000-10,700 min⁻¹** (100 min⁻¹ intervals).

Dry-running protection:

If "Setpoint" is used to reduce the speed, the dry-running protection will apply only in the "maximum speed" range (i.e. maximum speed less 1,000 min⁻¹). See section 2.6.1 *Function*.

Relation to other displays:

The setting in display 12.1.1 *Setpoint* is overridden by the "Max." and "Min." settings in display 12.1.2 *Operating mode*.

If "Closed loop" is selected in display 12.4.1 *Controller*, the setpoint is set within the setting range of the installed sensor.

Example: If the sensor input no. 1 is connected to a pressure sensor using the unit metre (m) and the measuring range (0-60), the setpoint can be set between 0 and 55 m in display 12.1.1 *Setpoint*.

12.1.2 Operating mode

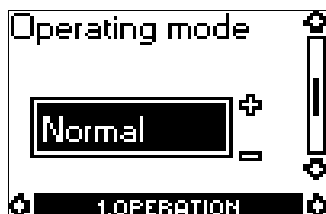

TM Sq1_02 GB

Select one of the following operating modes:

- **Max.**
Pump operation is set to maximum speed, irrespective of setpoint. The maximum speed is set in display 12.4.8 *Maximum speed* (default: 10,700 min⁻¹).
- **Normal.**
Normal operating mode, i.e. pump operation is based on the setpoint set in display 12.1.1 *Setpoint*.
Examples: Speed set in display 12.1.1 *Setpoint* or sensor control.
- **Min.**
Pump operation is set to minimum speed, 7,000 min⁻¹, irrespective of setpoint.
- **Stop.**
The pump is stopped.

If the On/Off button has been used to stop the pump, this button must also be used for restarting.

Relation to other displays:

The "Max." and "Min." settings override the setpoint setting in display 12.1.1 *Setpoint*.

12.1.3 Alarm

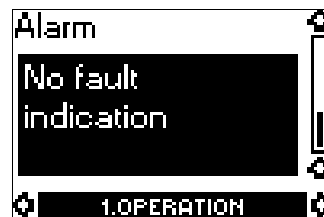

TM Sq1_03 GB

This display shows the types of alarm that may occur.

Possible alarms are described in the following table:

Alarm indication	Description
No fault indication	No alarms are registered by the CU 300.
No contact to pump	No communication between the CU 300 and the pump.
Overvoltage	The supply voltage exceeds the limit value.
Undervoltage	The supply voltage is below the limit value.
Dry running	The dry-running protection of the pump has been activated.
Overtemperature	The motor temperature exceeds the limit value.
Overload	The current consumption of the motor exceeds the limit value.
Alarm, sensor 1	The sensor 1 signal has fallen outside the measuring range set. Note: The sensor number refers to the terminal connection input number.
Alarm, sensor 2	The sensor 2 signal has fallen outside the measuring range set. Note: The sensor number refers to the terminal connection input number.
Sensor 1 defective	The sensor signal of a 4-20 mA or 2-10 V sensor is below 2 mA or 1 V respectively.
Sensor 2 defective	The sensor signal of a 4-20 mA or 2-10 V sensor is below 2 mA or 1 V respectively.
Warning, sensor 1	The sensor 1 warning limit has been exceeded.
Warning, sensor 2	The sensor 2 warning limit has been exceeded.
Warning, temperature	The temperature warning limit has been exceeded.
Digital alarm: low flow	The installation has been set up for "constant water level" by means of a flow switch. The flow is lower than 0.18 m ³ /h.

12.2 Menu STATUS

The STATUS menu for the CU 300 provides operating data about pump/motor and sensors. It is not possible to change or set values in this menu.

When [OK] is pressed continuously in this display, the displayed value is being updated.

The measuring accuracy is stated in section 13. *Technical data*.

12.2.1 Operating mode

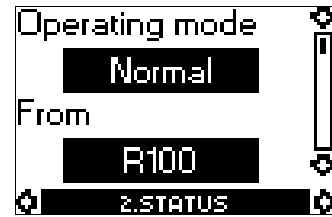

TM Sq2_01 GB

Possible operating modes:

- *Max.*
Pump operation has been set to maximum speed, e.g. 10,700 min⁻¹.
- *Normal.*
Normal operating mode, i.e. pump operation is based on the setpoint setting made in display 12.1.1 *Setpoint*.
- *Min.*
Pump operation has been set to minimum speed, 7,000 min⁻¹.
- *Stop.*
The pump has stopped.

The operating mode was selected from one of the following:

- *CU 300* (On/Off button on the CU 300).
- *R100*.
- *Dig* (signals received via digital input).
- *Sensor 1* (signals received via sensor 1 input).
- *Sensor 2* (signals received via sensor 2 input).

12.2.2 Actual setpoint and external setpoint

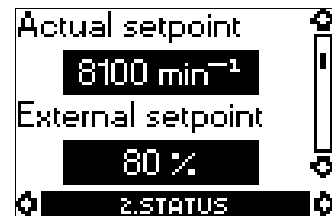

TM Sq2_02 GB

This display shows the actual setpoint and the external setpoint in % of the range from minimum value to the setpoint set.

Readings to be used in the following two situations:

- in installations including a potentiometer or
- in large SCADA systems (SCADA = Supervisory Control and Data Acquisition).

Relation to other displays:

The readings of this display are based on the settings made in display 12.4.2 *External setpoint* and 12.1.1 *Setpoint*.

External setpoint:

Possible readings: 0-100%.

Tolerance: ±5%.

12.2.3 Temperature

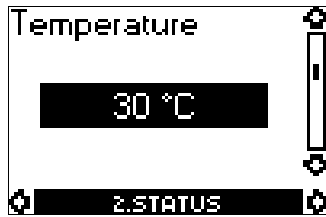

TM Sq2_03 GB

The actual temperature of the motor electronics stated in "°C" or "°F".

Tolerance: ±5%.

Relation to other displays:

To select "F", choose the language "US English".

12.2.4 Speed



TM Sq2_04 GB

The actual speed stated in min^{-1} (rpm).

Tolerance: ±1%.

12.2.5 Power input and power consumption

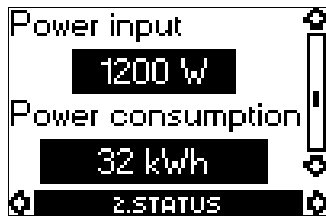

TM Sq2_05 GB

Power input:

The actual motor power from the electricity supply. The power input is displayed in W (watt).

Note: This value is used for the calculation of dry-running power limit (dry-running stop).

Power consumption:

The accumulated motor power consumption in kWh.

The value of power consumption is accumulated from the pump's birth and it cannot be reset.

The value

- is stored in the motor electronics, and it is kept even if the CU 300 is replaced.
- is updated in the software every 2 minutes of continuous operation. The displayed value is updated every two hours.

Tolerance: ±5%.

12.2.6 Operating hours and number of starts



TM Sq2_06 GB

Operating hours:

The value of operating hours is accumulated from the pump's birth and it cannot be reset.

The value

- is stored in the motor electronics, and it is kept even if the CU 300 is replaced.
- is updated in the software every 2 minutes of continuous operation. The displayed value is updated every two hours.

Number of starts:

The value of number of starts is accumulated from the pump's birth and it cannot be reset.

The value is stored in the motor electronics, and it is kept even if the CU 300 is replaced.

12.2.7 Sensor 1 and sensor 2



TM Sq2_07 GB

The actual values of sensor 1 and sensor 2 respectively.

12.2.8 Digital input

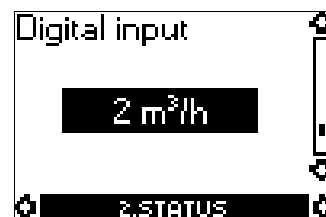

TM Sq2_08 GB

The actual value (flow) registered by the digital sensor based on an I/pulse detection.

Minimum value displayed: 0.1 m^3/h .

Relation to other displays:

This display is available only if "Type" is set to "Flow" in display 12.3.10 Digital input.

12.2.9 Accumulated flow and energy per m³

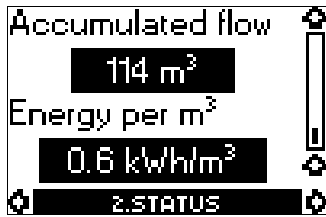

TM Sq2_09 GB

In this display, the following can be read:

- The water quantity (m³) pumped.
- Energy per m³.
The energy used to pump 1 m³ (instantaneous value).

Relation to other displays:

This display is available only if a sensor is selected in display 12.3.11 Accumulated flow. The accumulated flow is registered by this sensor.

12.3 Menu LIMITS

The LIMITS menu for the CU 300 offers the possibility of setting limit values for pump/motor and sensor operation. It is possible to set both stop, warning and alarm limits in this menu.

Factory settings are marked in **bold-faced** type under each individual display. See also table on page 46.

12.3.1 Sensor 1

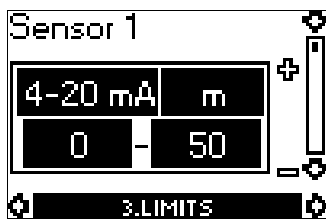

TM Sq3_01 GB

Make the following settings according to sensor type:

- Sensor output signal: “-” (not active), **0-20 mA**, **4-20 mA**, **0-10 V**, **2-10 V**.
- Setting range unit: **m³/h**, **m**, **%**, **GPM**, **ft**.

Setting range:

- Minimum value: **0-249** (0, 1, 2,249).
- Maximum value: **1-250** (1, 2,250).

12.3.2 Stop, sensor 1

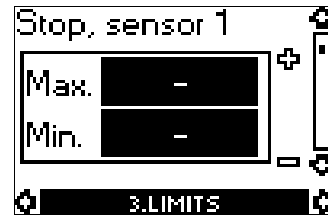

TM Sq3_02 GB

Set the maximum and minimum stop limits of sensor 1.

Setting range/unit:

- Maximum value: “-” (not active), possible settings according to the setting in display 12.3.1 Sensor 1.
- Minimum value: “-” (not active), possible settings according to the setting in display 12.3.1 Sensor 1.

12.3.3 Warning, sensor 1

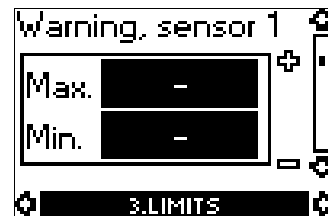

TM Sq3_03 GB

Set the maximum and minimum warning limits of sensor 1.

Setting range/unit:

- Maximum value: “-” (not active), possible settings according to the setting in display 12.3.1 Sensor 1.
- Minimum value: “-” (not active), possible settings according to the setting in display 12.3.1 Sensor 1.

12.3.4 Alarm, sensor 1



TM Sq3_04 GB

Set the maximum and minimum alarm limits of sensor 1.

Setting range/unit:

- Maximum value: “-” (not active), possible settings according to the setting in display 12.3.1 Sensor 1.
- Minimum value: “-” (not active), possible settings according to the setting in display 12.3.1 Sensor 1.

12.3.5 Sensor 2

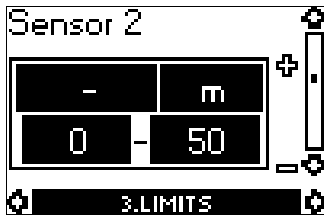

TM Sq3_05 GB

Make the following settings according to sensor type:

- Sensor output signal: “-” (not active), 0-20 mA, 4-20 mA, 0-10 V, 2-10 V.
- Setting range unit: m³/h, m, %, GPM, ft.

Setting range:

- Minimum value: 0-249 (0, 1, 2, ...,249).
- Maximum value: 1-250 (1, 2, ...,250).

Relation to other displays:

If a selection is made in display 12.4.2 External set-point, display 12.3.5 Sensor 2 is not available - and vice versa.

12.3.6 Stop, sensor 2

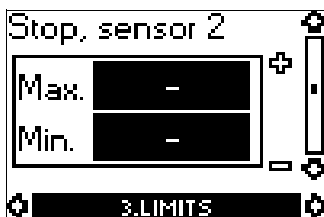

TM Sq3_06 GB

Set the maximum and minimum stop limits of sensor 2.

Setting range/unit:

- Maximum value: “-” (not active), possible settings according to the setting in display 12.3.5 Sensor 2.
- Minimum value: “-” (not active), possible settings according to the setting in display 12.3.5 Sensor 2.

Relation to other displays:

If a selection is made in display 12.4.2 External set-point, display 12.3.6 Stop, sensor 2 is not available.

12.3.7 Warning, sensor 2

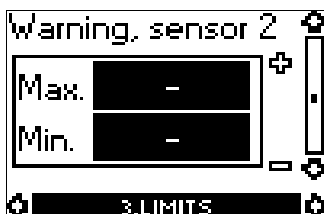

TM Sq3_07 GB

Set the maximum and minimum warning limits of sensor 2.

Setting range/unit:

- Maximum value: “-” (not active), possible settings according to the setting in display 12.3.5 Sensor 2.
- Minimum value: “-” (not active), possible settings according to the setting in display 12.3.5 Sensor 2.

Relation to other displays:

If a selection is made in display 12.4.2 External set-point, display 12.3.7 Warning, sensor 2 is not available.

12.3.8 Alarm, sensor 2

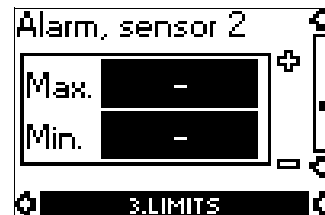

TM Sq3_08 GB

Set the maximum and minimum alarm limits of sensor 2.

Setting range/unit:

- Maximum value: “-” (not active), possible settings according to the setting in display 12.3.5 Sensor 2.
- Minimum value: “-” (not active), possible settings according to the setting in display 12.3.5 Sensor 2.

Relation to other displays:

If a selection is made in display 12.4.2 External set-point, display 12.3.8 Alarm, sensor 2 is not available.

12.3.9 Stop type



TM Sq3_09 GB

Select the stop function of the sensors connected.

The following functions are available:

- *Fill.*
The pump must start at a given minimum water level and stop at a given maximum level.
- *Empty.*
The pump must start at a given maximum water level and stop at a given minimum level.

12.3.10 Digital input

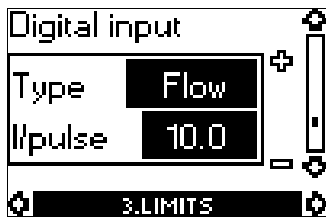

TM Sq3_10 GB

Select the function of either

- the digital sensor connected to the digital input (flow measuring) or
- the external on/off switch for the pump.

The following functions are available:

- “-” (not active).
- *Stop.*
The pump is stopped when a switch connected to terminals 12 and 13 is closed. No l/pulse to be set. See section 2.5.4 *Digital input.*
- *Start.*
The pump is started when a switch connected to terminals 12 and 13 is closed. No l/pulse to be set. See section 2.5.4 *Digital input.*
- *Flow.*
If “Flow” is selected, the l/pulse value must also be set.
Setting range: “-” (not active), 0.1, 0.2, 0.3,20, 21, 22,100 l/pulse.

Relation to other displays:

The selection of “Flow” in this display makes display 12.2.8 *Digital input* available, i.e. status of digital input.

12.3.11 Accumulated flow



TM Sq3_11 GB

Stop:

Set the pump stop when a given water quantity has been pumped.

Setting range: “-” (not active), 0.1, 0.2, 0.3,20, 21, 22,100 m³.

The pump stops when the set quantity is reached. By pressing the On/Off button twice, the accumulated quantity is reset and the pump is restarted.

Sensor:

Set the sensor to detect the water quantity.

The following settings are available:

- “-” (not active).
- 1.
Analog sensor input 1.

- 2.
Analog sensor input 2.
- *Dig.*
Digital sensor input.

Relation to other displays:

If a sensor is selected in this display, display 12.2.9 *Accumulated flow and energy per m³* is made available.

12.3.12 Warning, temperature

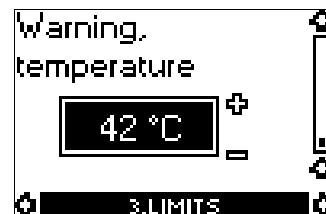

TM Sq3_12 GB

Set the temperature warning limit of the motor.
Setting range: “-” (not active), 2, 4, 6,85°C.

Note: The maximum temperature depends on the motor type.

Set the temperature warning limit between normal operating temperature and maximum temperature.

Relation to other displays:

The actual operating temperature is seen in display 12.2.3 *Temperature.*

If the temperature warning limit is exceeded, the alarm signal relay operates.

Advantage: Instead of a sudden stop without a warning, you get:

- information that the motor temperature is rising and
- the possibility of planning service of the installation.

Usage: This function can be used e.g. if the pumped liquid contains a relatively high level of ochre.

12.4 Menu INSTALLATION

The INSTALLATION menu for the CU 300 offers the possibility of configuring the CU 300, pump/motor and sensors.

Factory settings are marked in **bold**-faced type under each individual display. See also table on page 46.

12.4.1 Controller

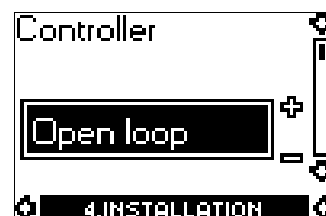

TM Sq4_01 GB

Select the controller type.

The following settings are available:

- **Open loop.**
The speed is:
set to normal operation based on the setpoint set in display 12.1.1 *Setpoint* (e.g. 10,700 min⁻¹) or controlled by means of a signal connected to sensor input 2.
See section 7. *CU 300 connected to potentiometer.*
- **Closed loop.**
Controlling according to sensor 1 (type and unit).
Example: Constant pressure control.
See section 4. *CU 300 with constant pressure control - 0 to 10 bar.*
Relation to other displays:
The unit (min⁻¹) of display 12.1.1 *Setpoint* is changed according to the unit of the sensor installed.

12.4.2 External setpoint

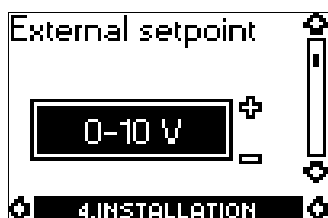

TM Sq4_02 GB

Set the pump performance control by means of external signal.

To be used in the following two situations:

- for installations including a potentiometer or
- in large SCADA systems.
In SCADA systems, this function makes it possible to control pump performance via remote controlling (e.g. via a PC).

The following settings are available:

- **SPP 1.**
GRUNDFOS potentiometer.
See section 1.1 *Expansion possibilities.*
- 4-20 mA.
- 0-20 mA.
- 2-10 V.
- 0-10 V.
- “-” (not active).
No external setpoint setting made.

Description:

By connecting a current or voltage signal to sensor input 2, it is possible to control the motor speed between the setpoint set in display 12.1.1 *Setpoint* and the lowest speed of 7,000 min⁻¹.

If the setpoint is set to 10,700 min⁻¹ in display 12.1.1 *Setpoint*, the motor speed can be changed between 7,000 and 10,700 min⁻¹.

The actual setpoint is calculated by the CU 300 and shown in display 12.2.2 *Actual setpoint and external setpoint.*

If an SPP 1 potentiometer is connected, the internal voltage supply of the CU 300 is used to generate the signal.

See section 7. *CU 300 connected to potentiometer.*

Relation to other displays:

If display 12.4.1 *Controller* is set to “Closed loop” instead of “Open loop” (factory setting), the controlling is based on signals from sensor 1. Therefore the unit in display 12.1.1 *Setpoint* is changed from min⁻¹ to the unit of sensor 1 (m³/h, m, %, GPM, ft).

If a setting is made in display 12.4.2 *External setpoint*, the displays:

- 12.3.5 *Sensor 2*,
- 12.3.6 *Stop, sensor 2*,
- 12.3.7 *Warning, sensor 2*, and
- 12.3.8 *Alarm, sensor 2*

are no longer available.

12.4.3 Automatic restart

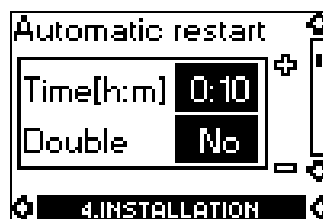

TM Sq4_03 GB

Set the automatic restart time from stop to restart attempt.

The following settings are available:

Time:

- **0:05.**
- “-” (not active).
- 1, 2, ..., 30 m (1 min. intervals),
30, 45, 1 h, ..., 2 h (15 min. intervals),
2 h 30 m, 3 h, ..., 4 h (30 min. intervals).

Double:

- Yes,
- **No.**

When “Yes” is selected, the restart time set will be doubled automatically for every 10 motor stops caused by an alarm. The time is doubled up to a stop time of 4 hours. After 10 hours of operation without an alarm, the restart time is automatically set to:

- the time set in the “Time” field or
- 5 min. (default) if no setting was made in the “Time” field.

Relation to other displays:

If “Double” is selected, the dewatering function is disabled.

12.4.4 Start delay

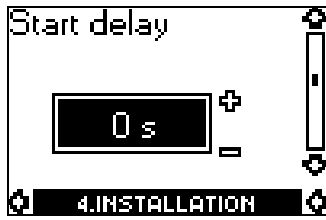

TM Sq4_04 GB

Set a start delay.

This function is used in installations having several pumps connected to the same pipeline and where it is required that the pumps do not start up at the same time.

The SQE pumps have a built-in soft starter. Therefore, the starting current is no problem.

Setting range: **0-60 s** (2 sec. intervals).

12.4.5 Run/Stop

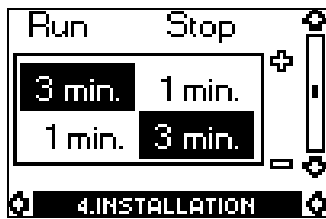

TM Sq4_05 GB

Set the Run and Stop times for the dewatering function.

See section 2.8 *Description of the dewatering function*.

Operating indication:

The dry-running alarm indication on the CU 300 is automatically disabled, when this display setting is made.

When the setting “-” is selected, the dewatering function is disabled, and the dry-running alarm indication can be activated again.

Run:

Run time, i.e. the period of time in which the pump is to run.

Setting range: “-” (not active), 1, 2, ...,60 min.

Stop:

Stop time, i.e. the period of time in which the pump is stopped.

Setting range: “-” (not active), 1, 2, ...,60 min.

Relation to other displays:

If “Double” is selected in display 12.4.3 *Automatic restart*, the dewatering function is disabled.

12.4.6 Dry-running stop



TM Sq4_06 GB

The dry-running stop value is factory-set.

The value depends on the actual motor.

The factory setting depends on the power rating of the motor, see section 13. *Technical data*.

When the dry-running protection or the dewatering function is to be active, the minimum value of the pump power input must be set in this display.

See section 2.8 *Description of the dewatering function*.

Setting range: **0-2500 W** (10 W intervals).

Relation to other displays:

12.4.7 *Dry-running protection* must be set to “Active”.

If “Double” is selected in display 12.4.3 *Automatic restart*, the dewatering function is disabled.

The actual pump power input can be read in display 12.2.5 *Power input and power consumption*.

12.4.7 Dry-running protection



TM Sq4_07 GB

The following settings are available:

- **Active**,
- *Not active*.

The setting in this display applies to both the dewatering function and the dry-running protection.

In certain installations, it may be necessary to disable the dry-running protection.

See section 2.6 *Description of dry-running protection*.

12.4.8 Maximum speed



TM Sq4_08 GB

Set the maximum speed.

Setting range: **7,000-10,700 min⁻¹** (100 min⁻¹ intervals).

12.4.9 Button on CU 300

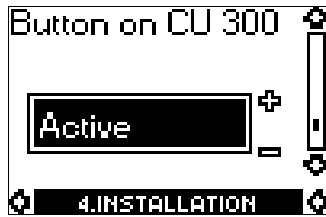

TM Sq4_09 GB

The On/Off button on the CU 300 can be set to:

- *Active*,
- *Not active*.

12.4.10 Number



TM Sq4_10 GB

Allocate a number to the CU 300 and the pump connected. The CU 300 and the pump must have the same number.

Setting range: “-” (not active), 1, 2,64.

Once a number setting has been made, the factory setting (not active) is no longer available.

In connection with BUS communication, a number **must** be allocated to the CU 300 and the pump.

If the CU 300 and the pump do not have the same number, the alarm “No contact” will be indicated.

13. Technical data

Supply voltage

1 x 100-240 V +6%/-10%, 50/60 Hz, PE.

Power consumption

5 W.

Back-up fuse

Maximum 16 A.

Current consumption

Maximum 130 mA.

Mains borne signalling

Frequency shift keying (FSK).
(132.45 kHz, ±0.6 kHz).

Enclosure class

IP 55.

Maximum length between CU 300 and pump

200 metres.

Ambient temperature

- During operation: -30 to +50°C
(must not be exposed to direct sunlight).
- During storage: -30 to +60°C.

Weight

2.0 kg.

Relative air humidity

Maximum 95%.

Materials

The CU 300 box is made of black PPO.

EMC (Electromagnetic compatibility)

According to EN 55 014 and EN 55 014-2.

Dimensional sketch

Fig. 54

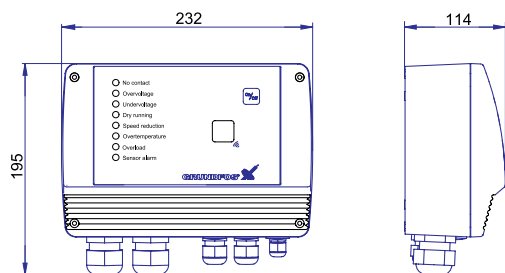

TM01 2781 2298

Inputs/output

Alarm relay	Potential-free changeover contact. Maximum contact load: 250 VAC. Maximum current: 1 A. Minimum contact load: 5 VDC, 10 mA. Specifications: 250 VAC/8A/AC1.
Auxiliary relay	Potential-free changeover contact. Maximum contact load: Safety extra-low voltage to be used only. Maximum current: 1 A. Minimum contact load: 5 VDC, 10 mA. Specifications: 250 VAC/8A/AC1.
Digital input	External potential-free contact. Logic "0": $U_{in} > 3.2$ V. Logic "1": $U_{in} < 0.9$ V.
Sensor 1	Voltage signal: 0-10 VDC/2-10 VDC, $R_i = 11$ k Ω . Tolerance: $\pm 3\%$ at maximum voltage signal. Screened cable is recommended. Maximum cable length: 500 m. Current signal: DC 0-20 mA/4-20 mA, $R_i = 500$ Ω . Tolerance: $\pm 3\%$ at maximum current signal. Screened cable is recommended. Maximum cable length: 500 m.
Sensor 2	Potentiometer SPP 1: 0-24 VDC, 10 k Ω (via internal voltage supply). Screened cable is recommended. Maximum cable length: 100 m. Voltage signal: 0-10 VDC/2-10 VDC, $R_i = 11$ k Ω . Tolerance: $\pm 3\%$ at maximum voltage signal. Screened cable is recommended. Maximum cable length: 500 m. Current signal: DC 0-20 mA/4-20 mA, $R_i = 500$ Ω . Tolerance: $\pm 3\%$ at maximum current signal. Screened cable is recommended. Maximum cable length: 500 m.
RS-485	GRUNDFOS field bus, GENIbus. 0.25 - 1 mm ² screened 2-core cable. Maximum cable length: 1200 m.
RS-232	Is not electrically separated. RI: Ring Indicator input from modem. DTR: Data Terminal Ready output to modem. RX 232: Input data. TX 232: Output data. GND: Ground.

Factory settings

Alarm	Connected motor (P2)		
	0.1 - 0.63 kW	0.7 - 1.05 kW	1.1 - 1.73 kW
Overvoltage *)	320 VAC	320 VAC	320 VAC
Undervoltage	Speed reduction: 190 V	Speed reduction: 190 V	Speed reduction: 210 V
	Stop limit: 150 V	Stop limit: 150 V	Stop limit: 150 V
Dry-running stop	300 W	680 W	800 W
Dry running	"Active" (R100 setting, display 12.4.7 Dry-running protection)		
Speed reduction	In connection with undervoltage or overload		
Overtemperature	Stop limit: 65°C	Stop limit: 65°C	Stop limit: 85°C
	Restart: 55°C	Restart: 55°C	Restart: 75°C
Overload	4 A	8 A	11 A
Sensor alarm	No sensor used (R100 setting, see section 12.3 Menu LIMITS)		

*) Operation is guaranteed up to 280 VAC. In order to avoid unnecessary stops, the overvoltage stop limit is as stated.

Accuracy of R100 readings

Operation

Display	Accuracy
12.2.2 External setpoint	±5%
12.2.3 Temperature	±5%
12.2.4 Speed	±1%
12.2.5 Power input	±5%
12.2.5 Power consumption	±5%
12.2.9 Energy per m ³	±5%

Sensors

The sensor signal accuracy depends on the sensor type. See the sensor specifications in question.

14. Disposal

Disposal of this product or parts of it must be carried out according to the following guidelines:

1. Use the local public or private waste collection service.
2. In case such waste collection service does not exist or cannot handle the materials used in the product, please deliver the product or any hazardous materials from it to your nearest GRUNDFOS company or service workshop.

Subject to alterations.

Denmark

GRUNDFOS DK A/S
Poul Due Jensens Vej 7A
DK-8850 Bjerringbro
Tlf.: +45-87 50 50 50
Telefax: +45-87 50 51 51

Argentina

Bombas GRUNDFOS de Argentina S.A.
Mexico 1404
(1640) Martinex
Buenos Aires
Phone: +54-11-4717 0090
Telefax: +54-11-4717 1091

Australia

GRUNDFOS Pumps Pty. Ltd.
P.O. Box 2040
Regency Park
South Australia 5942
Phone: +61-8-8461-4611
Telefax: +61-8-8346 2313

Austria

GRUNDFOS Pumpen Vertrieb
Ges.m.b.H.
Grundfosstraße 2
A-5082 Grödig/Salzburg
Tel.: +43-6246-883-0
Telefax: +43-6246-883-30

Belgium

N.V. GRUNDFOS Bellux S.A.
Boomsesteenweg 81-83
B-2630 Aartselaar
Tél.: +32-3-870 7300
Télécopie: +32-3-870 7301

Brazil

GRUNDFOS do Brasil Ltda.
Rua Tomazina 106
CEP 83325 - 040
Pinhais - PR
Phone: +55-41 668 3555
Telefax: +55-41 668 3554

Canada

GRUNDFOS Canada Inc.
2941 Brighton Road
Oakville, Ontario
L6H 6C9
Phone: +1-905 829 9533
Telefax: +1-905 829 9512

China

GRUNDFOS Pumps (Shanghai)
Co. Ltd.
22 Floor, Xin Hua Lian Building
755-775 Huai Hai Rd, (M)
Shanghai 200020
PRC
Phone: +86-21-64 67 28 09
Telefax: +86-21-64 67 28 08

Czech Republic

GRUNDFOS s.r.o.
Cajkovského
779 00 Olomouc
Phone: +420-68-5716 111
Telefax: +420-68-543 8908

Finland

OY GRUNDFOS Pumput AB
Mestarintie 11
Piispankylä
FIN-01730 Vantaa (Helsinki)
Phone: +358-9 878 9150
Telefax: +358-9 878 91550

France

Pompes GRUNDFOS Distribution
S.A.
Parc d'Activités de Chesnes
57, rue de Malacombe
F-38290 St. Quentin Fallavier
(Lyon)
Tél.: +33-4 74 82 15 15
Télécopie: +33-4 74 94 10 51

Germany

GRUNDFOS GMBH
Willy Pelz Straße 1-5
D-23812 Wahlstedt/Holstein
Tel.: +49-4554-98-0
Telefax: +49-4554-98 7399/7355

Greece

GRUNDFOS Hellas A.E.B.E.
20th km. Athinon-Markopoulou Av.
P.O. Box 71
GR-19002 Peania
Phone: +30-1-66 83 400
Telefax: +30-1-6646273

Hong Kong

GRUNDFOS Pumps (Hong Kong)
Ltd.
Unit 1, Ground floor
Siu Wai Industrial Centre
29-33 Wing Hong Street &
68 King Lam Street, Cheung Sha
Wan
Kowloon
Phone: +852-27861706/27861741
Telefax: +852-27858664

Hungary

GRUNDFOS Hungária Kft.
Lakatos u. 65
H-1184 Budapest
Phone: +36-1296 0620
Telefax: +36-1290 5534

India

GRUNDFOS Pumps India Private
Limited
Flat A, Ground Floor
61/62 Chamiers Aptmt
Chamiers Road
Chennai 600 028
Phone: +91-44 432 3487
Telefax: +91-44 432 3489

Indonesia

PT GRUNDFOS Pompa
Jl. Rawa Sumur III, Blok III / CC-1
Kawasan Industri, Pulogadung
Jakarta 13930
Phone: +62-21-460 6909
Telefax: +62-21-460 6910/460 6901

Ireland

GRUNDFOS (Ireland) Ltd.
Unit 34, Stillorgan Industrial Park
Blackrock
County Dublin
Phone: +353-1-2954926
Telefax: +353-1-2954739

Italy

GRUNDFOS Pompe Italia S.r.l.
Via Gran Sasso 4
I-20060 Truccazzano (Milano)
Tel.: +39-02-95838112/95838212
Telefax: +39-02-95309290/
95838461

Japan

GRUNDFOS Pumps K.K.
1-2-3, Shin Miyakoda
Hamamatsu City
Shizuoka pref. 431-21
Phone: +81-53-428 4760
Telefax: +81-53-484 1014

Korea

GRUNDFOS Pumps Korea Ltd.
2nd Fl., Dong Shin Building
994-3 Daechi-dong, Kangnam-Ku
Seoul 135-280
Phone: +82-2-5317 600
Telefax: +82-2-5633 725

Malaysia

GRUNDFOS Pumps Sdn. Bhd.
7 Jalan Peguam U1/25
Glenmarie Industrial Park
40150 Shah Alam
Selangor
Phone: +60-3-519 29 22
Telefax: +60-3-519 28 66

Mexico

Bombas GRUNDFOS de Mexico
S.A. de C.V.
Boulevard TLC No. 15
Parque Industrial Stiva Aeropuerto
Apodaca, N.L. 66600
Mexico
Phone: +52-8-144 4000
Telefax: +52-8-144 4010

Netherlands

GRUNDFOS Nederland B.V.
Pampuslaan 190
NL-1382 JS Weesp
Tel.: +31-294-492 211
Telefax: +31-294-492244/492299

New Zealand

GRUNDFOS Pumps NZ Ltd.
17 Beatrice Tinsley Crescent
North Harbour Industrial Estate
Albany, Auckland
Phone: +64-9-415 3240
Telefax: +64-9-415 3250

Norway

GRUNDFOS Pumper A/S
Stramsveien 344
Postboks 235, Leirdal
N-1011 Oslo
Tlf.: +47-22 90 47 00
Telefax: +47-22 32 21 50

Poland

GRUNDFOS Pompy Sp. z o.o.
ul. Klonowa 23
Baranowo k. Poznania
PL-62-081 Przemierowo
Phone: +48-61-650 13 00
Telefax: +48-61-650 13 50

Portugal

Bombas GRUNDFOS (Portugal)
Lda.
Rua Calvet de Magalhães, 241
Apartado 1079
P-2780 Paço de Arcos
Tel.: +351-21-440 76 00
Telefax: +351-21-440 76 90

Russia

OOO GRUNDFOS- Service
Center
Shkolnaya, ul., 39
RUS-109544 Moscow
Phone: +7-095 271 00 00
Telefax: +7-095 271 09 39

Singapore

GRUNDFOS (Singapore) Pte. Ltd.
24 Tuas West Road
Jurong Town
Singapore 638381
Phone: +65-861 5381
Telefax: +65-861 8402

Spain

Bombas GRUNDFOS España S.A.
Camino de la Fuentecilla, s/n
E-28110 Algete (Madrid)
Tel.: +34-91-848 8800
Telefax: +34-91-628 0465

Sweden

GRUNDFOS AB
Box 63, Angeredsvinkeln 9
S-424 22 Angered
Tel.: +46-31-332 23 00
Telefax: +46-31 331 94 60

Switzerland

GRUNDFOS Pumpen AG
Bruggacherstrasse 10
CH-8117 Fällanden/ZH
Tel.: +41-1-806 8111
Telefax: +41-1-806 8115

Taiwan

GRUNDFOS Pumps (Taiwan) Ltd.
14, Min-Yu Road
Tunglo Industrial Park
Tunglo, Miaoli County
Taiwan 366, R.O.C.
Phone: +886-37-98 05 57
Telefax: +886-37-98 05 70

Thailand

GRUNDFOS (Thailand) Ltd.
947/168 Moo 12, Bangna-Trad
Rd., K.M. 3,
Bangna, Phrakonong
Bangkok 10260
Phone: +66-2-744 1785 ... 91
Telefax: +66-2-744 1775 ... 6

Turkey

GRUNDFOS POMPA SAN. ve
TIC. LTD. STI
Bulgurlu Caddesi no. 32
TR-81190 Üsküdar Istanbul
Phone: +90 - 216-4280 306
Telefax: +90 - 216-3279 988

United Arab Emirates

GRUNDFOS Gulf Distribution
P.O. Box 16768
Jebel Ali Free Zone
Dubai
Phone: +971-4- 8815 166
Telefax: +971-4-8815 136

United Kingdom

GRUNDFOS Pumps Ltd.
Grovebury Road
Leighton Buzzard/Beds. LU7 8TL
Phone: +44-1525-850000
Telefax: +44-1525-850011

U.S.A.

GRUNDFOS Pumps Corporation
3131 North Business Park Avenue
Fresno, CA 93727
Phone: +1-559-292-8000
Telefax: +1-559-291-1357

Addresses revised 31.07.2000

96 42 79 72

V7 14 46 90 08 00	GB
Repl. V7 14 46 90 10 99	

GRUNDFOS®

