



Model PFC-1-G (direct acting) PFC-1-GR (reverse acting) Modulating Pneumatic Liquid Level Controls

APPLICATIONS:

- Use with other pneumatic devices, for liquid level sensing in tank or pressure vessel where electrical processes are not suitable, such as certain hazardous locations.

Features:

- A float-operated, modulating, pneumatic level controller
- Side-mounting pipe connections
- Direct or reverse action convertible
- Field adjustable operating range & proportioning band

Ratings:

Maximum Vessel Pressure: 250 psig (17.6 kg/cm²)

Maximum Fluid Temperature: 406° F (208°C)

Maximum Supply Air Pressure: 20 psig (1.4 kg/cm²)

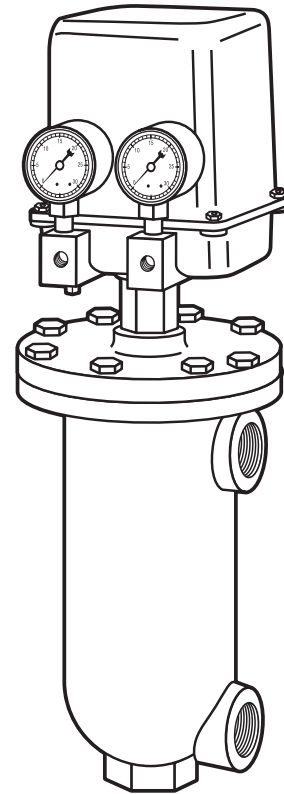

WARNING



- Before using product, read and understand instructions.



- Save these instructions for future reference.



- All work must be performed by qualified personnel trained in the proper application, installation, and maintenance of plumbing, steam, and electrical equipment and/or systems in accordance with all applicable codes and ordinances.



- If tank or receiver is pressurized relieve pressure to 0 psi (0 Bar) before servicing. Drain water level down and let cool to 80°F (27°C).

- Boiler manufacturer schematics should always be followed. In the event that the boiler manufacturer's schematic does not exist, or is not available from the boiler manufacturer, refer to the schematics provided in this document.

- To prevent water damage check to make sure there is adequate floor drainage capacity. Check all components in the system to insure they will not leak in the event of an overfeed condition.



- After installation, check for proper operation of all of the limit and operating controls before leaving the site.

- California Proposition 65 warning! This product contains chemicals known to the state of California to cause cancer and birth defects or other reproductive harm.

- Previous controls should never be installed on a new system. Always install new controls on a new boiler or system.

Failure to follow this warning could cause property damage, personal injury or death.

CAUTION:

- A more frequent replacement interval may be necessary based on the condition of the unit at time of inspection. McDonnell & Miller's warranty is one (1) year from date of installation or two (2) years from the date of manufacture.

OPERATION

FACTORY SETTINGS

DIRECT ACTING—MODEL PFC-1-G - The higher the liquid level, the higher the output pressure. Control can be changed to Reverse Acting.

REVERSE ACTING—MODEL PFC-1-GR - The higher the liquid level, the lower the output pressure. Control can also be changed to Direct Acting.

NOTE: Pneumatic operated valves are also available as either Direct Acting or Reverse Acting. When control and valve are the same—both Direct Acting or Reverse Acting—the valve opens as liquid level falls. When they are not the same, valve opens as level rises.

MAXIMUM PROPORTIONAL BAND—Control goes through its full operating range—from 3 to 15 psi output—with 2" of level change inside the float chamber. The proportional band can be adjusted to as little as 1" of level change.

SET POINT—The mark cast on float housing indicates the low point of the control operating range. The operating level to be maintained in the tank should be 1" above this mark. This set point can be field adjusted about 3/4".

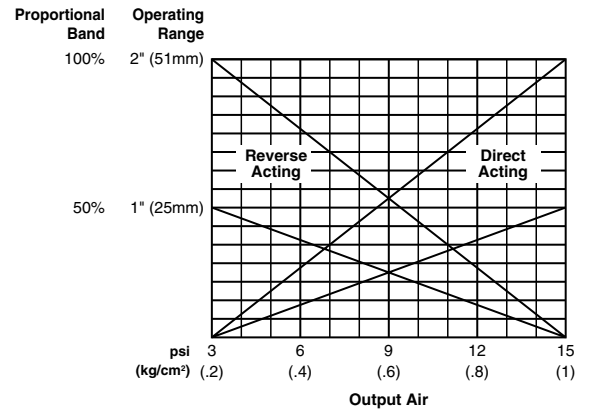

The model PFC is float operated, and mounts on the side of the tank or pressure vessel. Its design allows field adjustment of operational level, adjustment of proportional band and conversion to either direct acting or reverse acting operation.

INSTALLATION – Boiler / Hydronic Installation

TOOLS NEEDED:

Two (2) pipe wrenches, one (1) flathead screw driver and pipe thread dope.

Piping Hook-up

IMPORTANT

Follow the boiler manufacturer's instructions along with all applicable codes and ordinances for piping, blow-down valve, water gauge glass, tri-cock and electrical requirements.

The model PFC should be installed vertically on the side of the tank or vessel and connected with 1" equalizing pipes. Plug all unused body connections. Control must be plumb, with no more than a 2°-3° slant in any direction. Control should be set with mark on casting 1" below the desired operating level in tank. Keep equalizing lines as short as possible and avoid creating any pockets. Crosses with plugs should be used at any right angle connections to facilitate cleaning. A blow-off valve should be installed to permit blowdown operation and draining the float chamber. All connections must be securely tightened in leak-tight arrangement.

Gauges should be positioned for convenient reading. Head assembly can be reoriented by removing 8 bolts in the top of the head assembly and repositioning the entire head as desired so gauges can be read conveniently.

NOTE

The control is factory set to the mark on the float housing and to maximum proportional band. If the proportional band is adjusted, the point of minimum output may be as much as 1/2" above the mark.

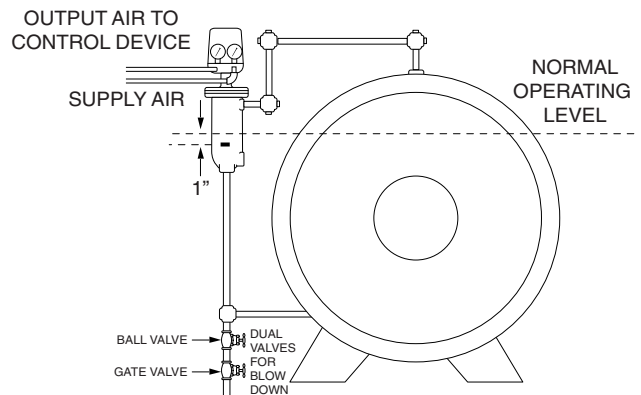

CAUTION

Remove float blocking plug and dowel pin, located in the bottom tapping of the control, before installation. Remove cardboard stop inside the top housing before putting control in operation.

When using tape sealants on pipe or fittings external threads follow the manufacturer's instructions—do not place tape on first thread. When using thread joint compound on pipe or fittings external threads follow manufacturer's instructions—use sparingly do not place compound on first thread.

CAUTION

Be sure to release pressure from float chamber before removing the 8 bolts.

TANK INSTALLATION

AIR SUPPLY CONNECTIONS

It is good practice to install an air filter in the air supply line. Control must be supplied with clean, dry instrument air at 20 psi. (Supply pressure in excess of 20 psi will cause a slight downward shift of the set point. Supply pressure less than 20 psi may not give sufficient output pressure to achieve control valve close-off.)

Connect air supply to either of the two 1/8" NPT ports directly below the gauge marked SUPPLY. Connect either of the two ports below gauge marked OUTPUT to valve or other control device. (Alternate ports are provided for convenience; be sure to plug the two ports not used with plugs provided.)

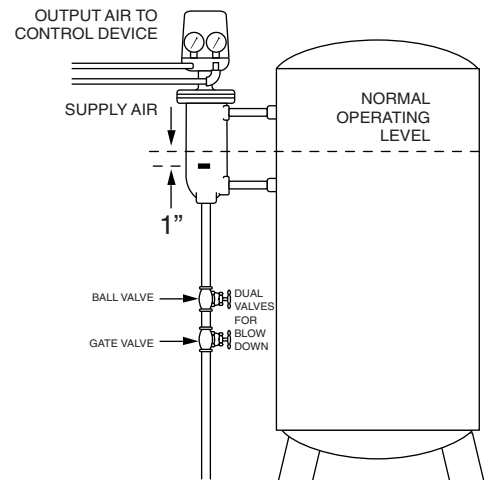
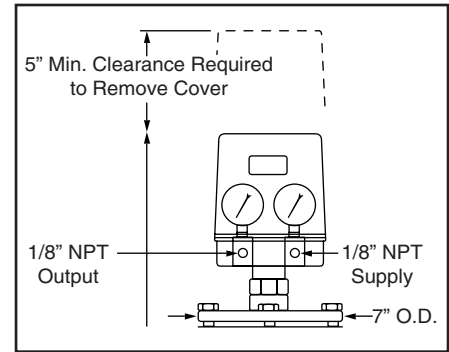

START-UP AND ADJUSTMENT PROCEDURE

To Start Operation (After all piping installation has been completed)

Remove cover from head of control. Carefully remove cardboard shipping stop under the yoke, by straightening the tabs on the sides and folding it lengthwise. Turn on air supply.

Check the supply gauge for proper air pressure—20 psi maximum. Gently swing the yoke through its full arc of travel to make sure the magnets do not rub against the tower tube (A).

Check the output gauge for proper output. Move the yoke through its full arc; output should range from 3 to 15 psi. With the yoke in a horizontal position, the output should be approximately 9 psi.

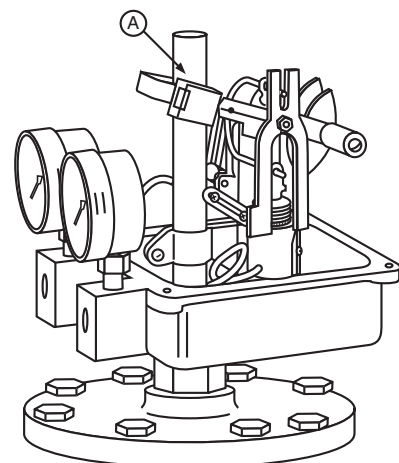

START-UP AND ADJUSTMENT PROCEDURE (continued)

To Adjust Air Output

When the control is placed in service, **and after any adjustment**, make sure of proper air output. With cover removed, and air supply turned on, check that the output gauge shows a range from 3 to 15 psi when the yoke is moved manually through a full arc of travel. With the yoke in horizontal position, the output should be approximately 9 psi.

If necessary to adjust: Loosen the two relay lock screws (C). Turn knurled adjusting collar (D) until output is 9 psi with yoke held in horizontal position. (Rotate the collar clockwise, when viewed from the top, to increase the output pressure or counter clockwise to decrease.) Tighten two lock screws securely.

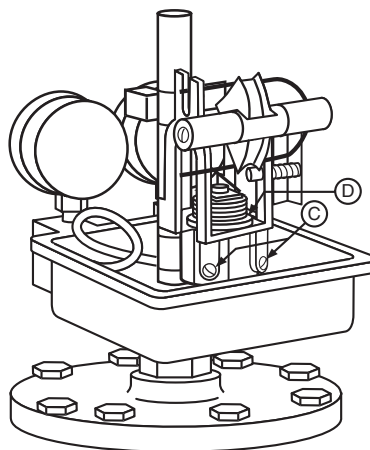

To Adjust Operating Level (Set Point)

For later reference, note proper orientation of control mechanism with base. Slightly loosen clamp screw (E), and slide control mechanism up or down on the tower tube. If practical, adjust the level of the liquid to desired control point, approximately 1" above the low level mark on the float housing.

Make sure mechanism is in proper orientation with base: the (M) yoke counterbalance weights should be parallel to the back side of the base. Then tighten clamp screw securely.

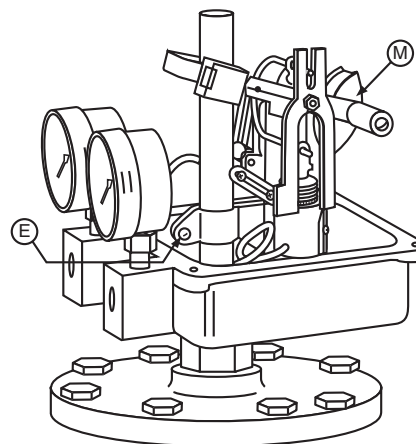

CAUTION

The position of the clamp screw must not be higher than the top surface of the mechanism housing. Positioning the mechanism too high may cause the magnets to disengage, resulting in loss of output control.

To Adjust Proportional Band

Loosen two locking screws at bottom of the proportional band spring bracket (F). Turn the proportional band adjusting screw (G) until the desired proportional band is attained. (Screw is full out for factory-set maximum band.) Tighten two locking screws in spring bracket securely.

NOTE

This adjustment may require several small incremental changes followed by operational checks before final setting is achieved.

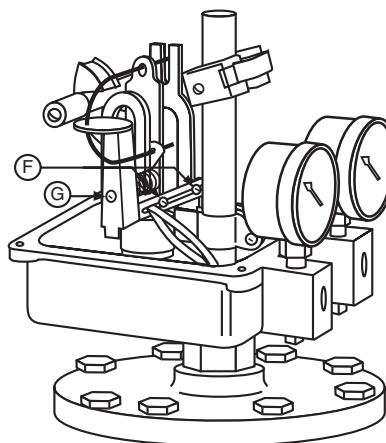

START-UP AND ADJUSTMENT PROCEDURE (continued)

To Change Direct Acting Operation to Reverse Acting Operation

Remove two locking screws at bottom of proportional band spring bracket (F). Remove proportional band adjusting screw and coil spring (G). Remove proportional band spring bracket and U-shaped proportional band spring (H). It may be necessary to compress U-shaped spring slightly to withdraw it from the upper spring follower (J) and lower guide (K).

Loosen two inner pivots (L), using a 5/16" open end wrench on the hex-shaped base of the pivots. Rotate counterweight (M) 180° until it rests on the stop. The eccentric will display DA when in the proper position for direct acting, and RA for reverse acting operation. Tighten the two inner pivots (L) securely against the yoke.

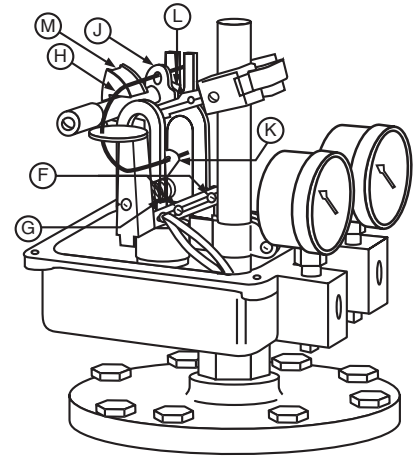

CAUTION

Overtightening could loosen the eccentric from the lead counterweight.

Swing spring follower (J) back to upright position. Carefully replace proportional band spring bracket and U-shaped proportional band spring (H), making sure that top leg of spring passes inside the spring follower and between the two upright arms, and the bottom leg passes inside the guide (K).

Replace proportional band adjusting screw and coil spring (G). Tighten adjusting screw until the lock screws (F) can be replaced through the slots in the proportional band spring bracket. Adjust proportional band as desired (see above) and tighten lock screws (F).

If Magnets Rub on Tower Tube

When the control is placed in service, and after any adjustment, make sure that magnets clear the tower tube. With cover removed, move the yoke manually through a full arc of travel.

CAUTION

One of the pivots on the yoke arm is spring loaded; any lateral force on the yoke may give a false picture of actual clearances.

If necessary to adjust: Loosen pivot screw lock nut (B), using a 11/32" wrench. Adjust pivot screw (not shown) in a direction to free the rubbing. When magnets clear tube properly, tighten lock nut securely, and make sure the yoke is engaged with internal armature.

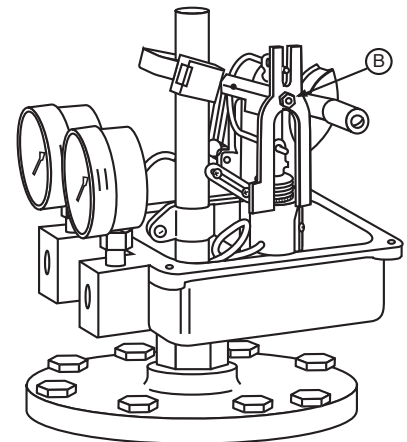

IMPORTANT

Perform the air output adjustment procedure after any other changes to the mechanism.

After installation, test the control for operating levels and reposition the mechanism, if necessary. Make sure the magnets are engaged with the internal armature. Engagement is indicated by resisting movement. Replace cover.

Troubleshooting

Shipment may cause the control to lose calibration. If erratic operation is observed:

- a. Check position of yoke movement relative to tube tower magnet movement.
- b. Position the clamp screw even with the rib of the mechanism housing.
- c. Perform ADJUST AIR OUTPUT procedure after any changes to mechanism.

Too much vibration of the control or float or rapid level changes may cause the magnets to disengage, resulting in a loss of output control. Manually re-engage the magnets by slowly moving the yoke through its entire range of motion until the magnets re-engage. If re-engagement does not occur, the float and internal magnet assembly may be damaged. Removal of the head from the chamber would then be required to correct the condition.

Internal (Wetted) Parts Dirty

The internal parts can operate improperly if dirt, scale or rust is allowed to build. This condition can be a result of not blowing down the control as recommended and/or improper boiler water chemical treatment.

Float is Crushed

Crushed floats are typically caused by improper blow-down. Drain piping from blow-down valve to drain should be checked for proper pitch and the blow-down procedure followed when blowing down the control. Purchase and install a new float ball after investigating and correcting the problem.

Float is Filled with Water

The seam weld on the float can sometimes deteriorate. This can be caused by the type of chemical treatment used in the boiler. While this is a rare occurrence, the chemical treatment supplier should be consulted to determine if a reaction could occur. Purchase and install a new float after investigating and correcting the problem.

MAINTENANCE

SCHEDULE:

- **Blow down control weekly to verify operation.** When this control is used as a boiler control, blow down control as follows when boiler is in operation
 - Daily if operating pressure is above 15 psi.
 - Weekly if operating pressure is below 15 psi.

NOTE

More frequent blow-down may be necessary due to dirty boiler water and/or local codes.

- **Disassemble and inspect annually.** Replace the controller if it is worn, corroded, or if components no longer operate properly.
- **Inspect the float, chamber and equalizing piping annually.** Remove all sediment and debris.
- **Replace control every 15 years.** More frequent replacement may be required when severe conditions exist.

PROCEDURE



CAUTION



To prevent serious personal injury from steam pipe blow down, connect a drain pipe to the control opening to avoid exposure to steam discharge. Failure to follow this caution could cause personal injury.

When blowing down a control at pressure, the blow-down valve should be opened slowly. The piping needs to be warmed up and stagnant water in the drain piping needs to be pushed out. Suddenly opening a blow-down valve causes steam to condense, which creates water hammer. Damage to components can occur when water hammer occurs due to improper blow-down piping. For these reasons, McDonnell & Miller recommends a dual valve blow-down system for each control.

1. With water in the boiler at its normal level, open "Positive Shut-off Ball Valve".
2. Open "Throttling Gate Valve" slowly until drain piping heats up and then open fully. Observe that the water level starts falling in the gauge glass.
3. Close "Throttling Gate Valve" after verifying that controlled air valve opens fully.

NOTE

If this does not happen, immediately close all valves, turn off burner and correct the problem.

4. Close "Positive Shut-off Ball Valve".
5. Observe that the water level returns to its normal level before leaving site.



Xylem Inc.
8200 N. Austin Avenue
Morton Grove, Illinois 60053
Phone: (847) 966-3700
Fax: (847) 965-8379
www.xylem.com/brands/mcdonnellmiller