

BLADE

L-SHAPE WORKSTATION

Includes Add-Ons: **A1 | A2 | A3 | A4**

General Installation Guide

EDITION CODE

BCC1-1 :: 54" W Return Surface or Smaller.....	1
BCC1-2 :: 60" W Return Surface	7
BCC1-2 :: 66" W Return Surface or Larger	15
BCC1-3 :: L-Shape with Steel Storage.....	21

ADD-ONS

A1 :: Surface-Mount Cable Management Tray.....	7
A2 :: Modesty Panel.....	11
A3 :: Laminate Inset End Panels.....	15
A4 :: Steel Inset End Panels	23

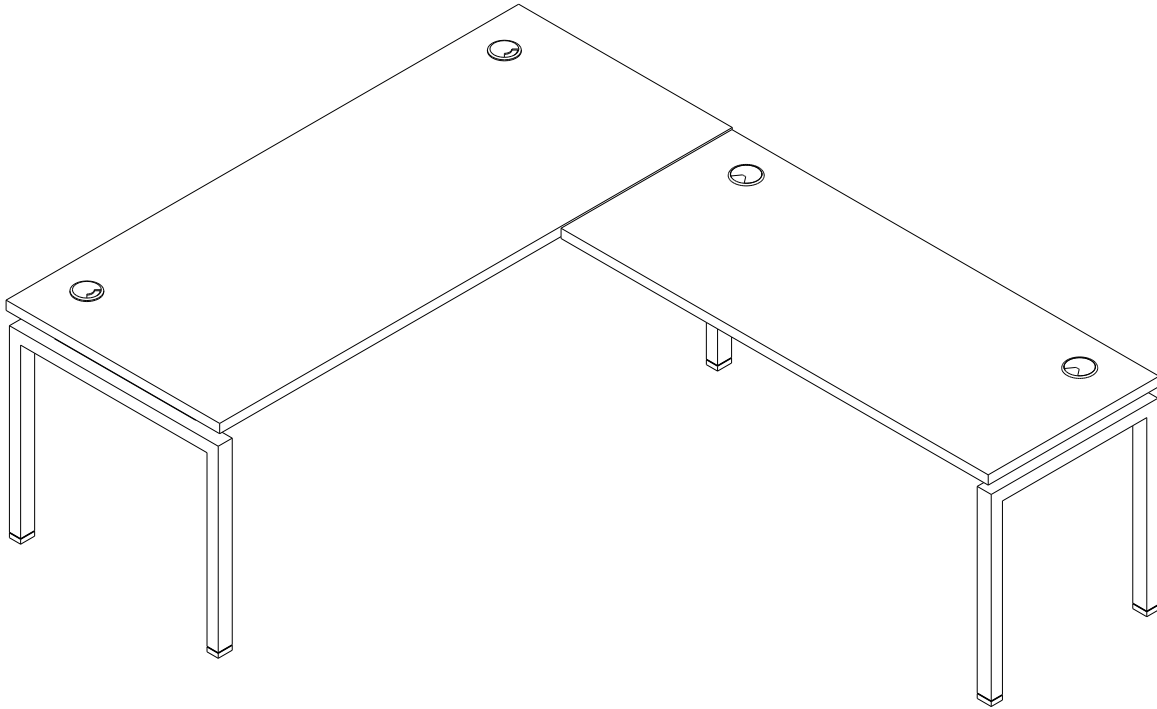













WORKSTATION WITH 54" W RETURN SURFACE OR SMALLER

OVERVIEW

BLADE L-Shape

! All parts listed are for a L-Shape workstation; additional parts will be needed for additional L-Shape workstations.

PARTS LIST

CODE	QTY	DESCRIPTION	
GB3072	1	Surface 30"x72"	
GB2448	1	Return Surface 24"x48"	
BB3	1	Extra Long Beam	
	2	Lock Plate	
	4	Cap Screw	
	1	Locking Screw and Lever	
BL30	2	BLADE 30" End Leg	
	12	Wood Screws	
BL24	1	BLADE 24" End Leg	
	6	Wood Screws	
BASB72	2	42" Support Bar*	
	20	Wood Screws	
BFB1	2	Flat Bracket	

*Support bars will be added to surfaces 72" and longer. If working with a 60" W return, skip to page 7.

1 | JOIN MAIN SURFACE 30" END LEGS WITH BEAM

Insert beam tabs into leg brackets. Guide beam tabs into bracket holes, ensuring that there is not a gap between the beam and legs. Using a rubber mallet, hammer the beam to lock in place.

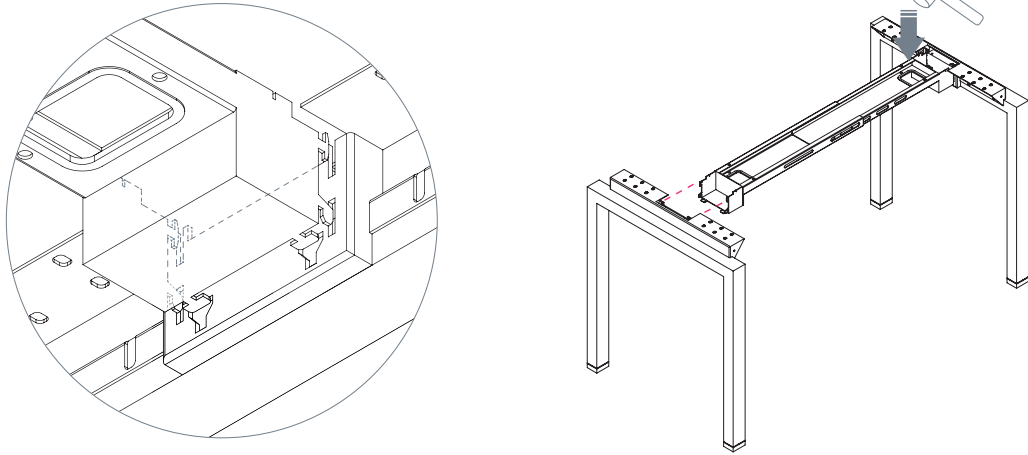

2 | BOLT DOWN BEAM-TO-LEG LOCK PLATE

Note: Beam lock plates will not fit if there is a gap between beam and leg.

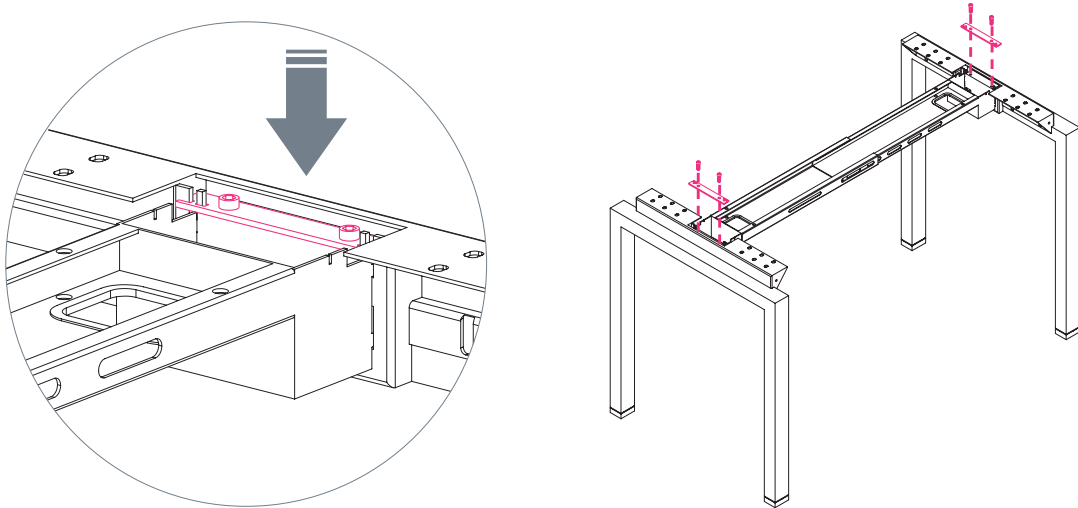

3 | MEASURE AND ADJUST BEAM WIDTH

Measure from end leg to end leg until you find the approximate width of the work surface. Insert the screw through the overlapping beam slots and into the locking screw and lever. Slightly tighten the screw. **DO NOT** fully tighten. Insert beam grommet covers.

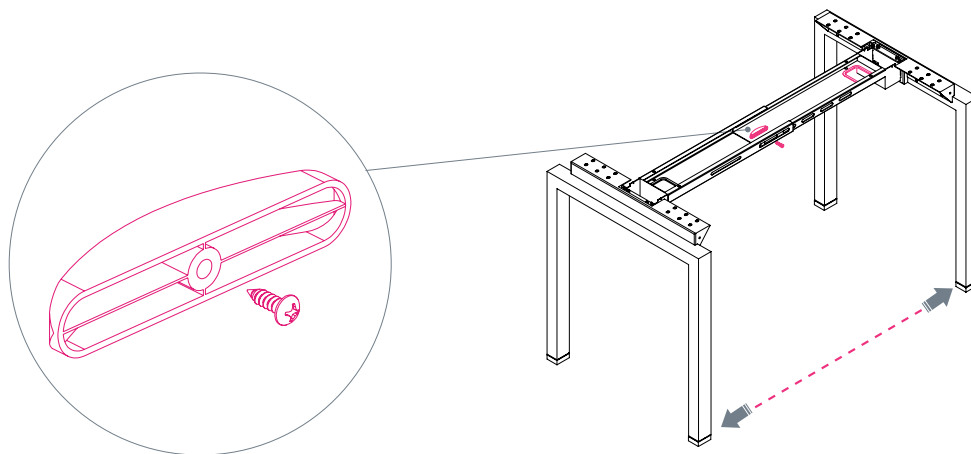

4 | SECURE MAIN SURFACE

Position surface on desk frame. Align outer sides of surface flush and parallel with outer sides of the end legs, adjust if not flushed. Insert wood screws into leg brackets and secure to underside of the surface.

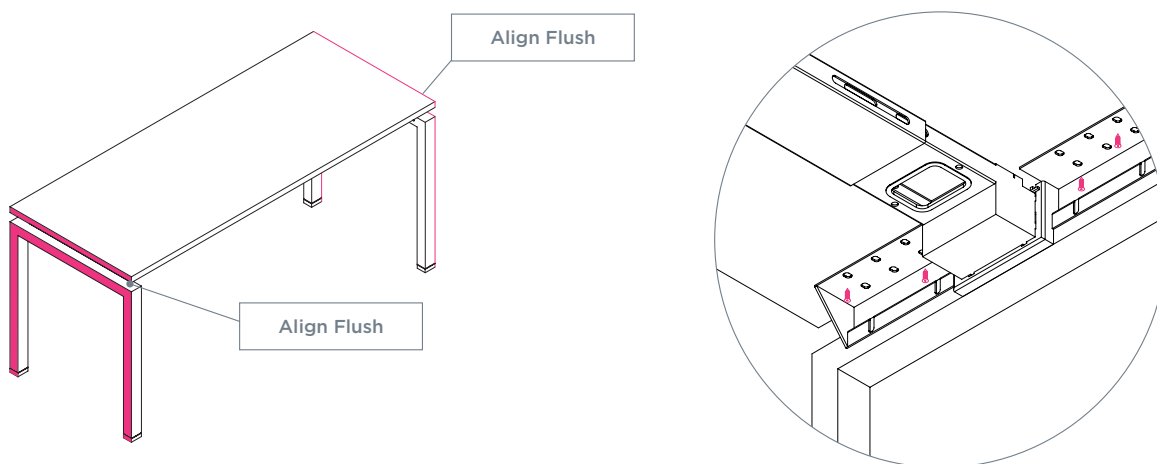

5 | SECURE SUPPORT HARDWARE TO MAIN SURFACE FOR RETURN SURFACE

Using 2 wood screws for each flat plate, secure plates to edge of main surface with half of the plates extended over edge of surface. Using 4 wood screws, secure support bar to underside of surface centered between flat plates.

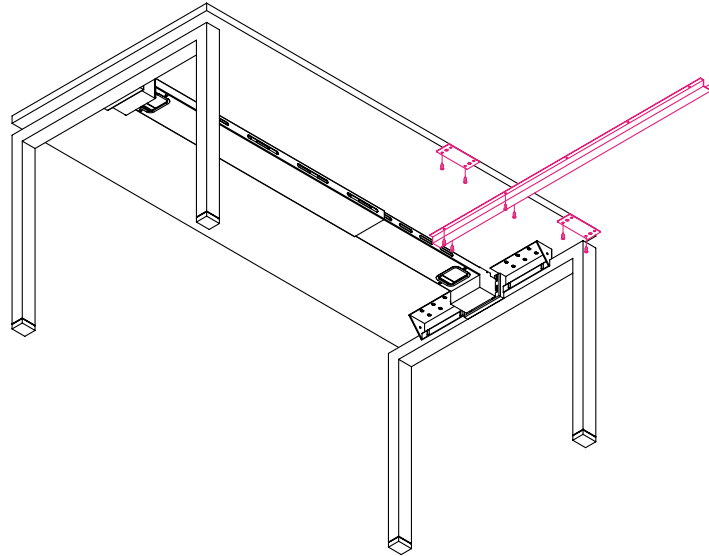

6 | ASSEMBLE RETURN SURFACE WITH 24" LEG

Assemble return surface by securing BL24 leg to underside of laminate surface with wood screws.

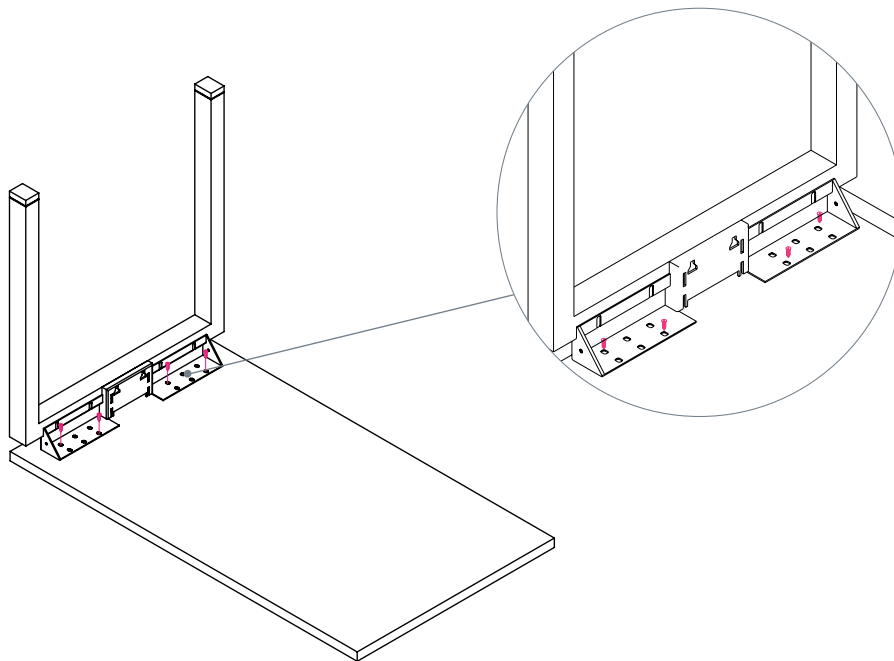

7 | ATTACH RETURN TO MAIN SURFACE

Align return surface with main surface and secure flat plates and supported bar with wood screws into the underside of surface. Tighten screw on main profile beam.

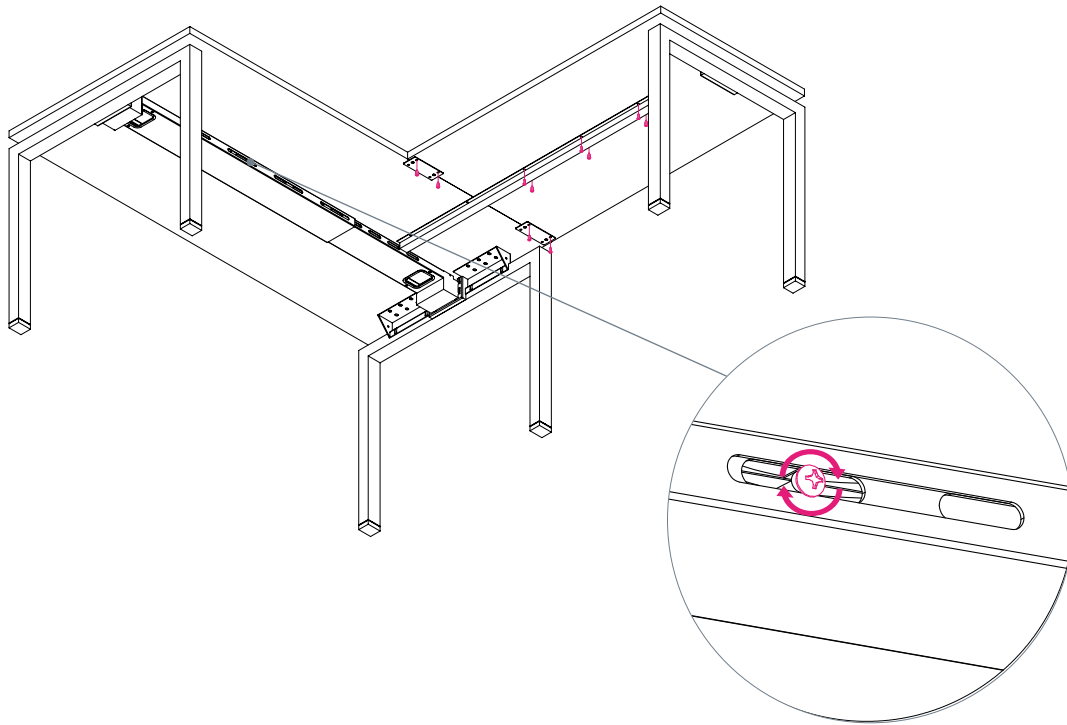

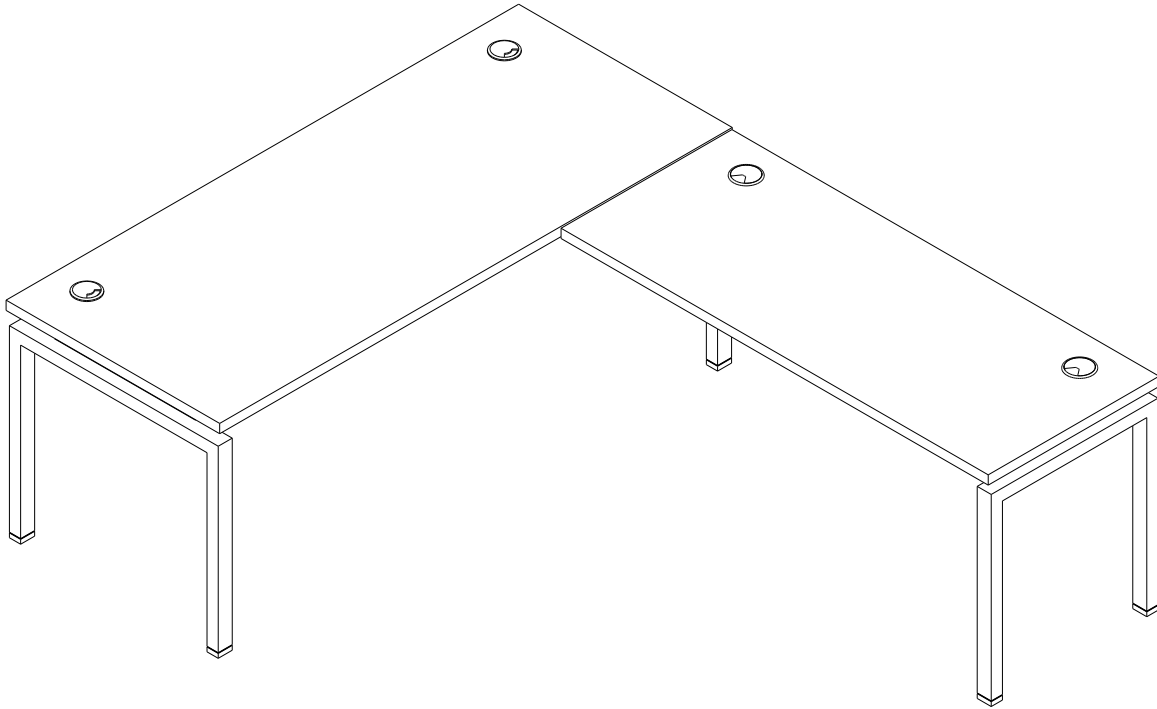













WORKSTATION WITH 60" W RETURN SURFACE

OVERVIEW

BLADE L-Shape

! All parts listed are for a L-Shape workstation; additional parts will be needed for additional L-Shape workstations.

PARTS LIST

CODE	QTY	DESCRIPTION	
GB3072	1	Surface 30"x72"	
GB2448	1	Return Surface 24"x60"	
BB3	2	Extra Long Beam	
	4	Lock Plate	
	8	Cap Screw	
	2	Locking Screw and Lever	
BL30	2	BLADE 30" End Leg	
	12	Wood Screws	
BL24	1	BLADE 24" End Leg	
	6	Wood Screws	
BASB72	2	42" Support Bar*	
	20	Wood Screws	
BFB1	2	Flat Bracket	

*Support bars will be added to surfaces 72" and longer. If working with a 66" W return or larger, skip to page 15.

1 | JOIN MAIN SURFACE 30" END LEGS WITH BEAM

Insert beam tabs into leg brackets. Guide beam tabs into bracket holes, ensuring that there is not a gap between the beam and legs. Using a rubber mallet, hammer the beam to lock in place.

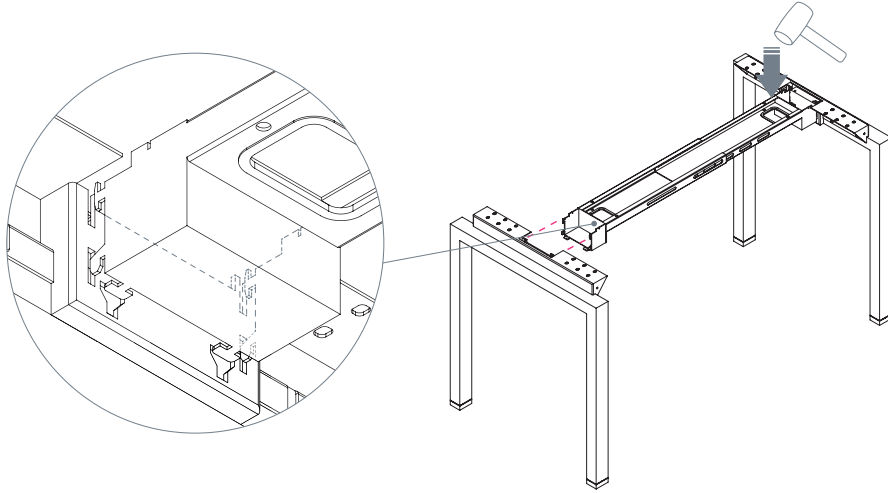

2 | BOLT DOWN BEAM-TO-LEG LOCK PLATE

Note: Beam lock plates will not fit if there is a gap between beam and leg.

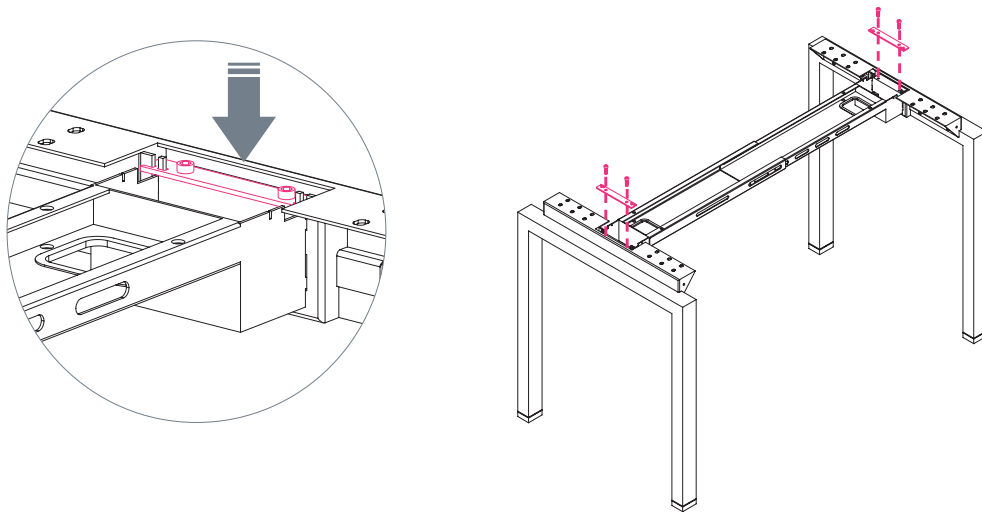

3 | MEASURE AND ADJUST BEAM WIDTH

Measure from end leg to end leg until you find the approximate width of work surface. Insert the screw through overlapping beam slots and into locking screw and lever. Slightly tighten screw. **DO NOT** fully tighten. Insert beam grommet covers.

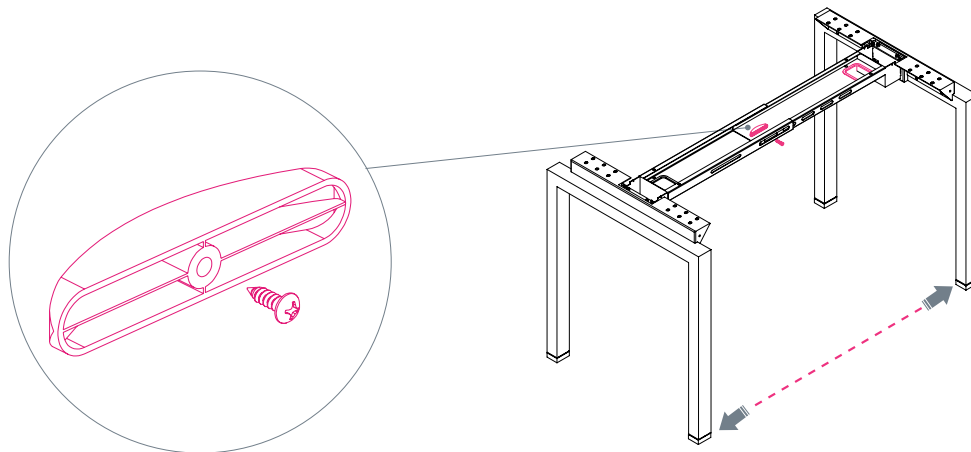

4 | JOIN 24" RETURN END LEG WITH SECOND BEAM

Guide the beam tabs into the bracket holes, ensuring that there is not a gap between beam and leg. Using a rubber mallet, hammer beam to lock in place.

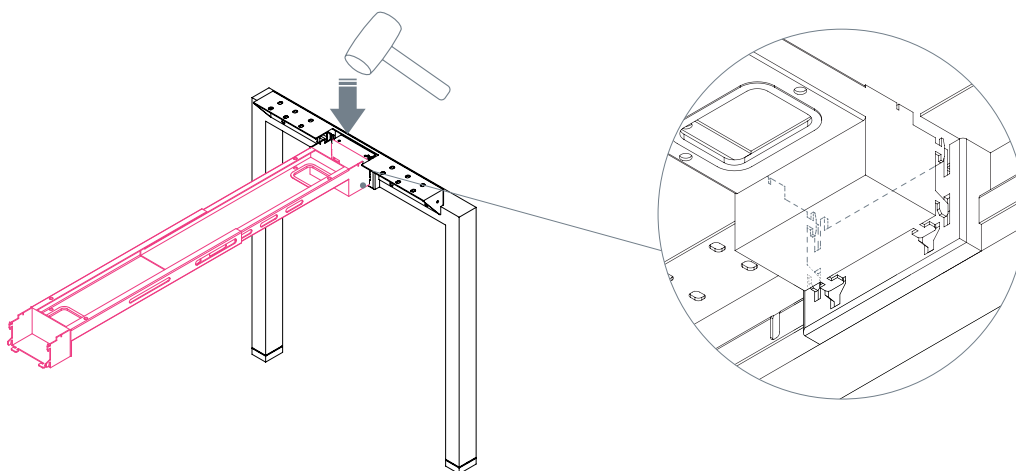

5 | ATTACH BB3 BEAM TO CONNECTOR BRACKET

Slide connector bracket over the side of the BLADE main surface beam. Once seated, guide return beam tabs into the bracket holes, ensure that there is no gap between the beam and legs. Using a rubber mallet, hammer beam to lock in place.

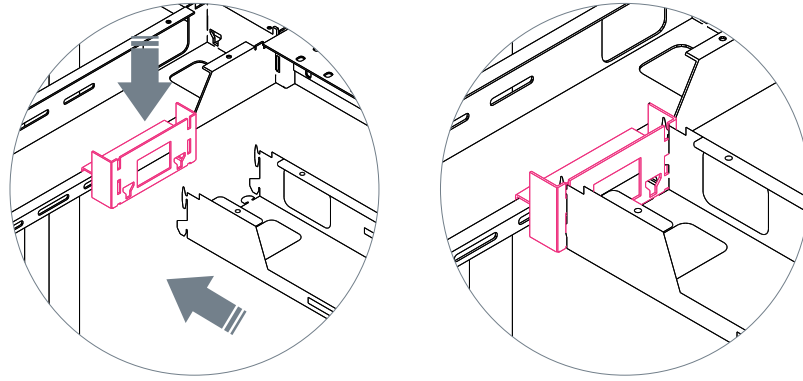

6 | MEASURE WIDTH AND LOCK INTO POSITION

Measure from end leg to end leg until you find the approximate width of the work surface. To find the optimal placement for locking, insert the screw through the overlapping beam slots and into the black plastic piece. Slightly tighten the screw with only a few turns. **DO NOT** fully tighten.

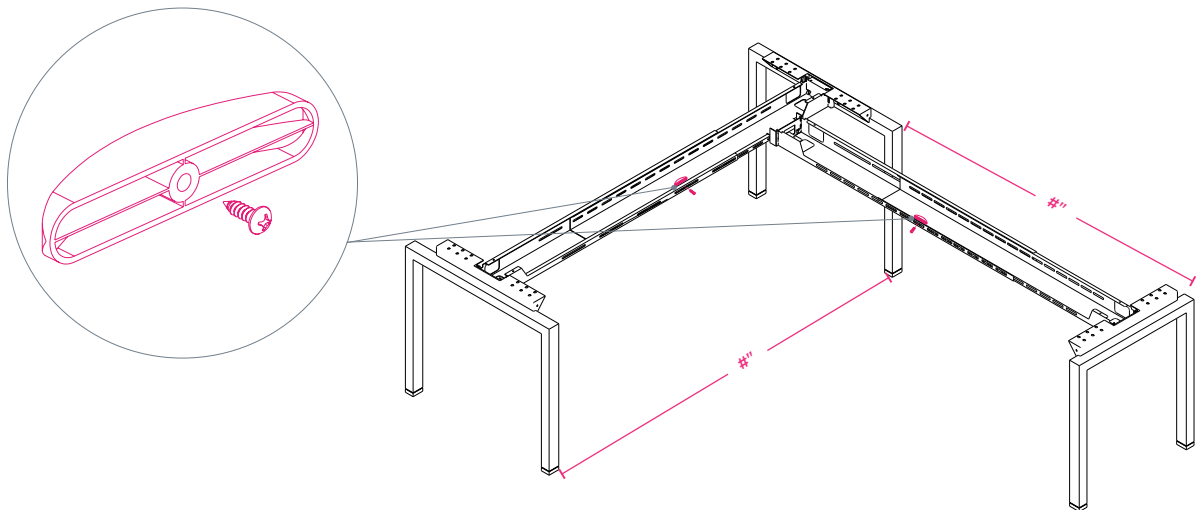

7 | SECURE MAIN SURFACE

Position the surface on the desk frame. Align the outer sides of the surface flush and parallel with the outer sides of the end legs. Adjust beam positions if sides are not flush. Fasten the surface to the desk frame with wood screws through the leg brackets into the underside of the surface.

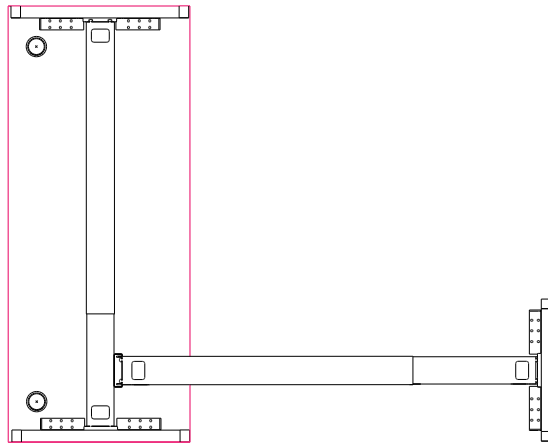
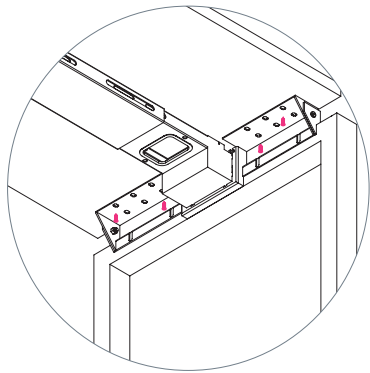

8 | SECURE RETURN SURFACE

Position the surface on the desk frame. Align the outer sides of the surface flush and parallel with the outer sides of the end legs. Adjust beam positions if sides are not flush. Fasten the surface to the desk frame with wood screws through the leg brackets into the underside of the surface.

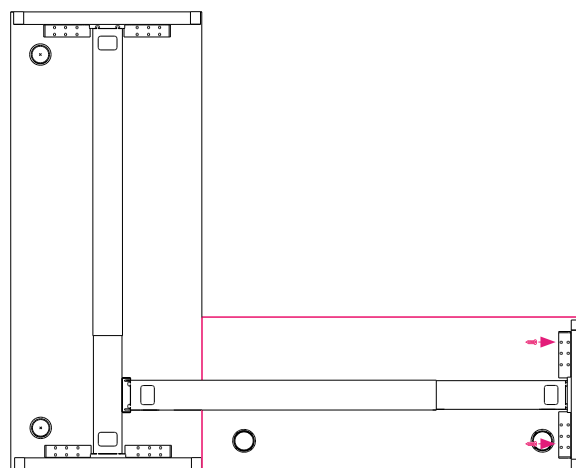
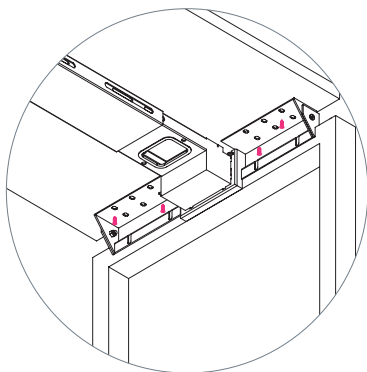

9 | SECURE SUPPORT BAR AND FLAT BRACKETS

Secure the flat plates to the end of the return and side of main surface with wood screws. Place support bars as shown below and secure to underside of surface using wood screws. Tighten the screw on the main profile beam.

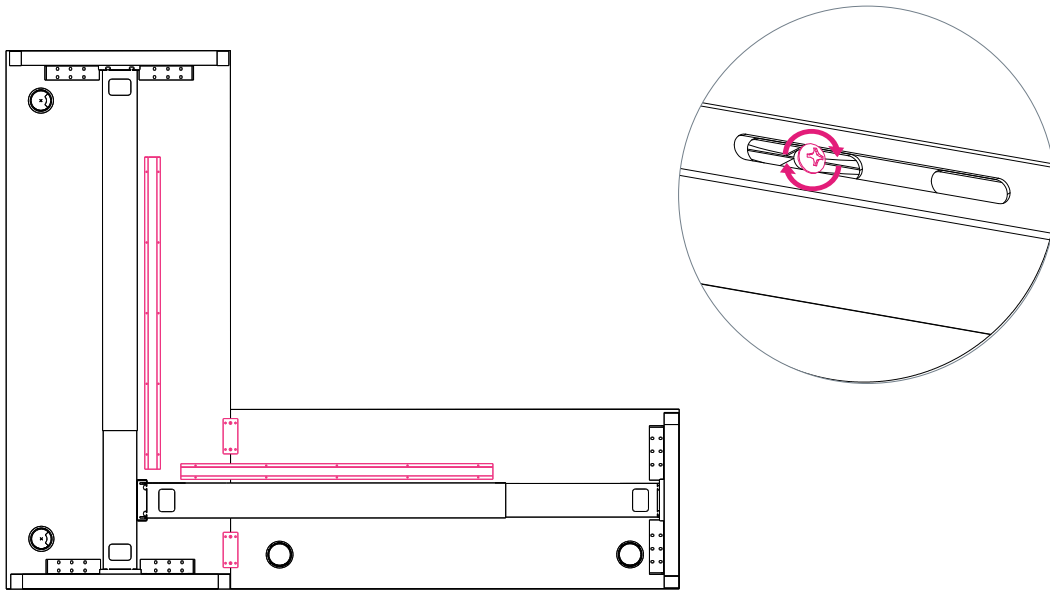

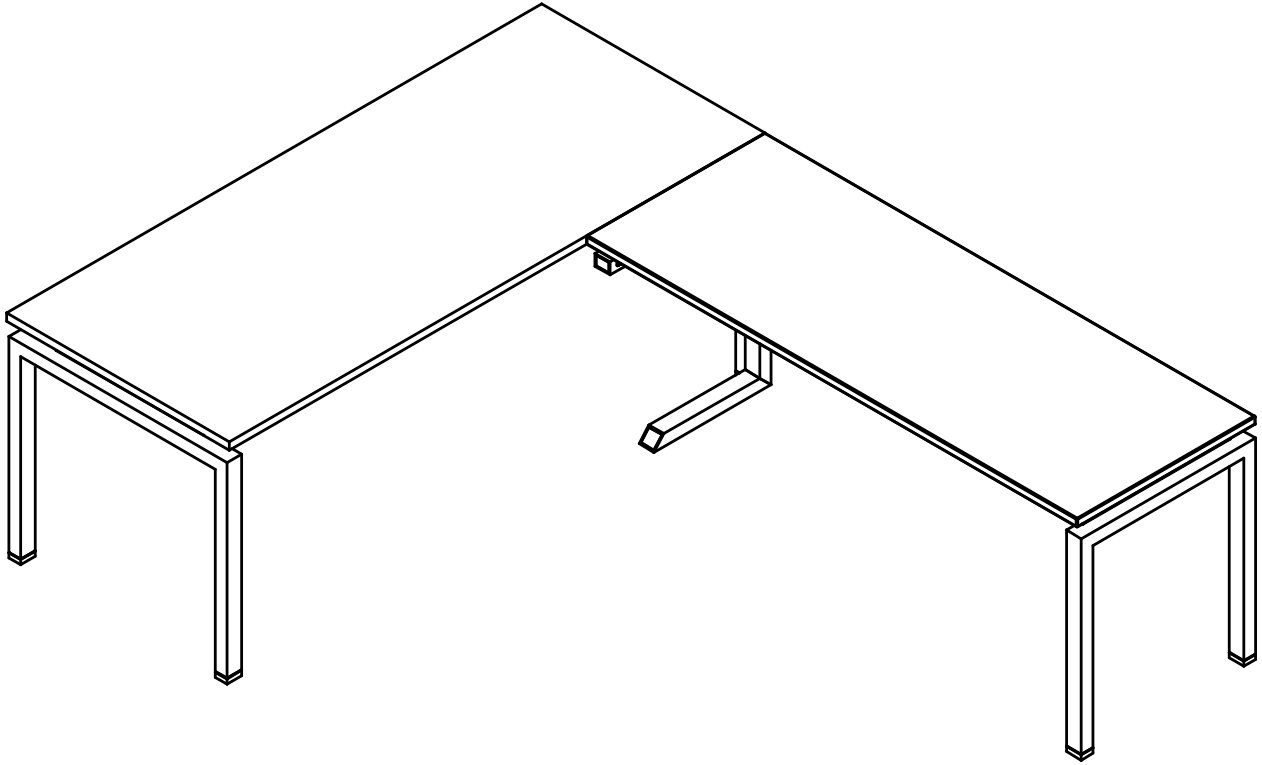











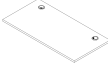



WORKSTATION WITH 66" W RETURN SURFACE OR LARGER

OVERVIEW

BLADE L-Shape

! All parts listed are for a L-Shape workstation; additional parts will be needed for additional L-Shape workstations.

PARTS LIST

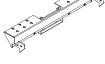
CODE	QTY	DESCRIPTION	
GB3072	1	Surface 30"x72"	
GB2466	1	Return Surface 24"x66"	
BB3	2	Extra Long Beam	
	4	Lock Plate	
	8	Cap Screw	
	2	Locking Screw and Lever	
BL30	2	BLADE 30" End Leg	
	12	Wood Screws	
BL24	1	BLADE 24" End Leg	
	6	Wood Screws	
BASB72	2	42" Support Bar*	
	20	Wood Screws	
BFB1	2	Flat Bracket*	
BCLEG	1	C-Leg	
BLC1	1	Leg Connecting Bracket	

*Support bars will be added to surfaces 72" and longer. Flat Brackets will be added when attaching return to main surface.

1 | JOIN MAIN SURFACE 30" END LEGS WITH BEAM

Insert beam tabs into leg brackets. Guide beam tabs into bracket holes, ensuring that there is not a gap between the beam and legs. Using a rubber mallet, hammer the beam to lock in place.

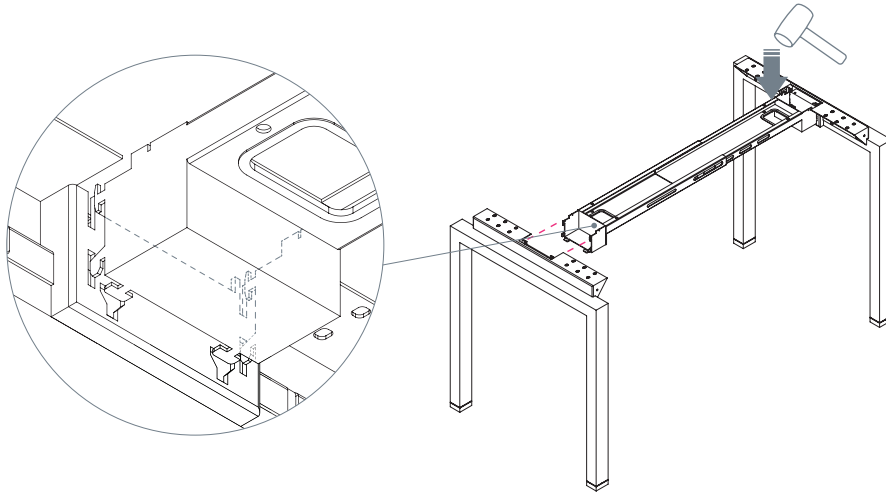

2 | BOLT DOWN BEAM-TO-LEG LOCK PLATE

Note: The beam lock plates will not fit if there is a gap between the beam and the leg.

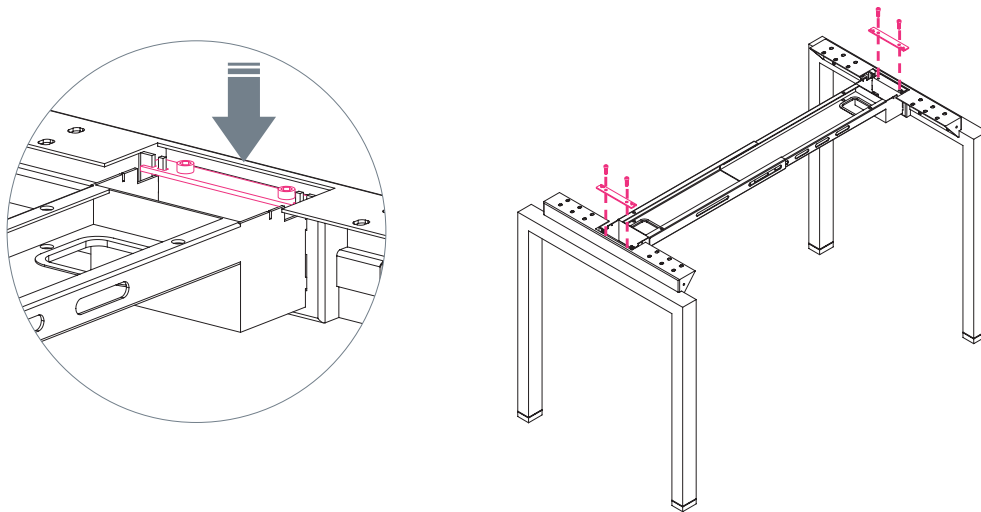

3 | MEASURE AND ADJUST BEAM WIDTH

Measure from end leg to end leg until you find the approximate width of the work surface. Insert the screw through the overlapping beam slots and into the locking screw and lever. Slightly tighten the screw. **DO NOT** fully tighten. Insert beam grommet covers.

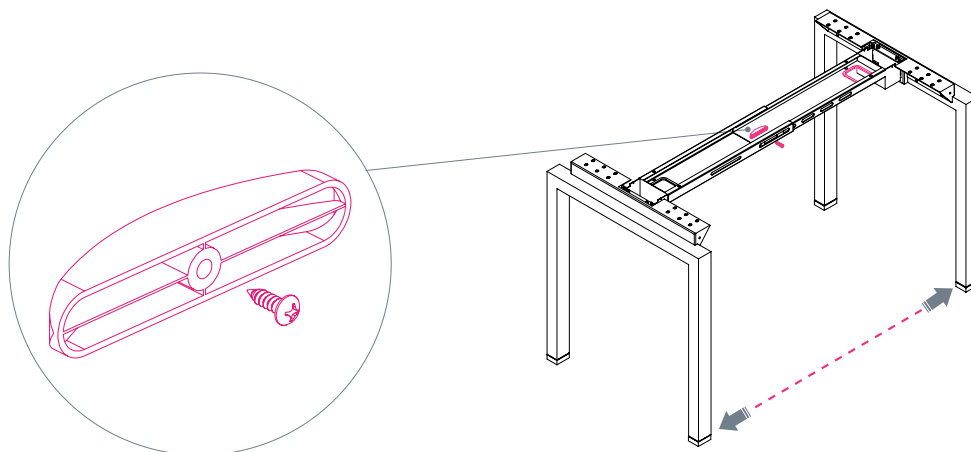

4 | SECURE MAIN SURFACE

Position the surface on the desk frame. Align the outer sides of the surface flush and parallel with the outer sides of the end legs, adjust if not flushed. Insert wood screws into the leg brackets and secure to the underside of the surface.

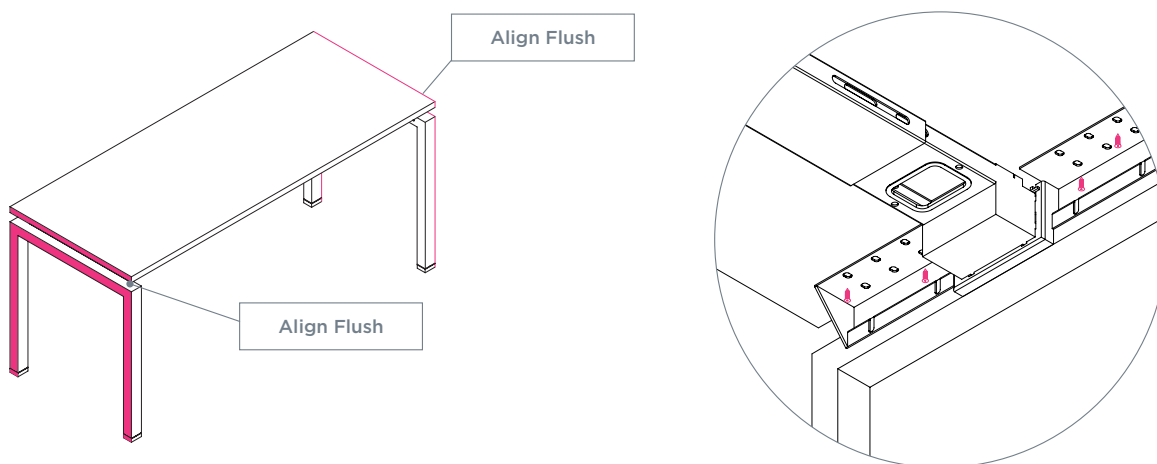

5 | ASSEMBLE C-LEG

Attach leg connecting bracket to C-leg using provided screws.

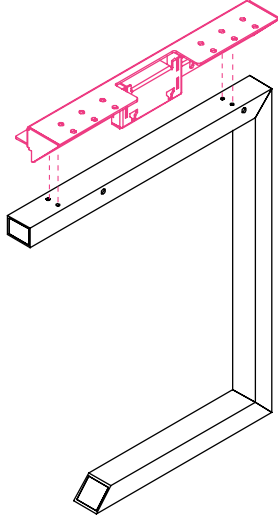

6 | JOIN RETURN LEGS WITH BEAM

Insert beam tabs into leg brackets. Guide beam tabs into bracket holes, ensuring that there is not a gap between the beam and legs. Using a rubber mallet, hammer the beam to lock in place.

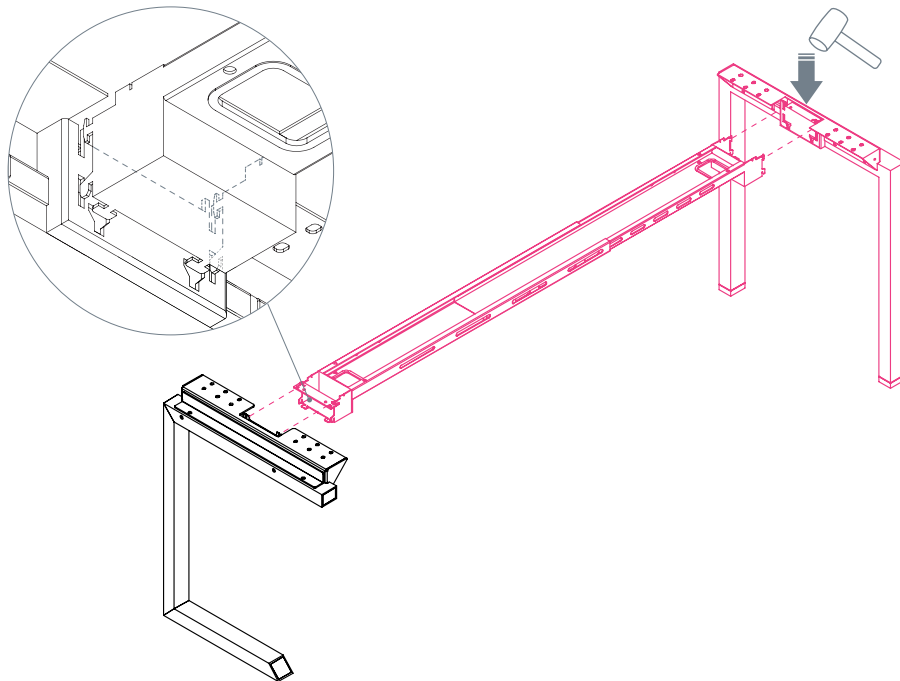

7 | MEASURE AND ADJUST BEAM WIDTH

Measure from end leg to end leg until you find the approximate width of the work surface. Insert the screw through the overlapping beam slots and into the locking screw and lever. Slightly tighten the screw. **DO NOT** fully tighten. Insert beam grommet covers.

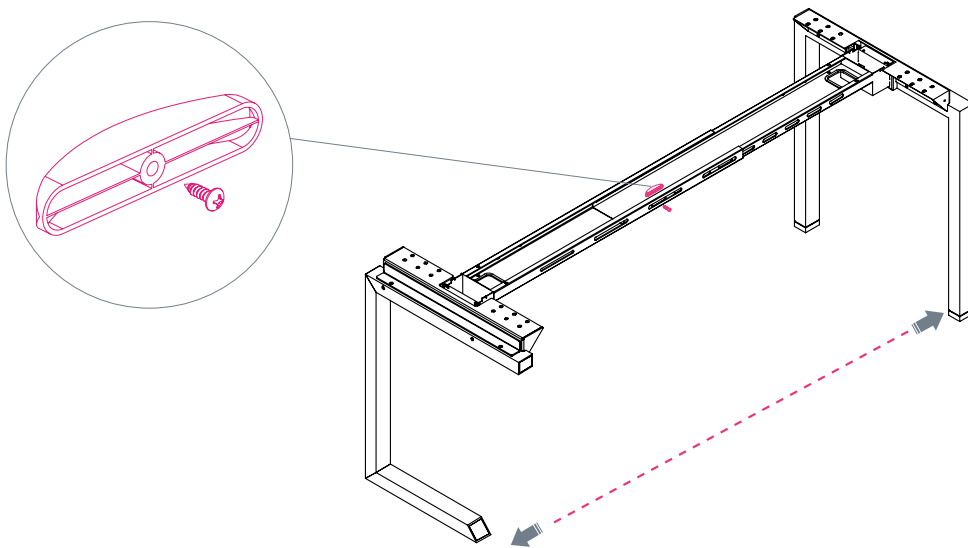

8 | BOLT DOWN BEAM-TO-LEG LOCK PLATE

Note: The beam lock plates will not fit if there is a gap between the beam and the leg.

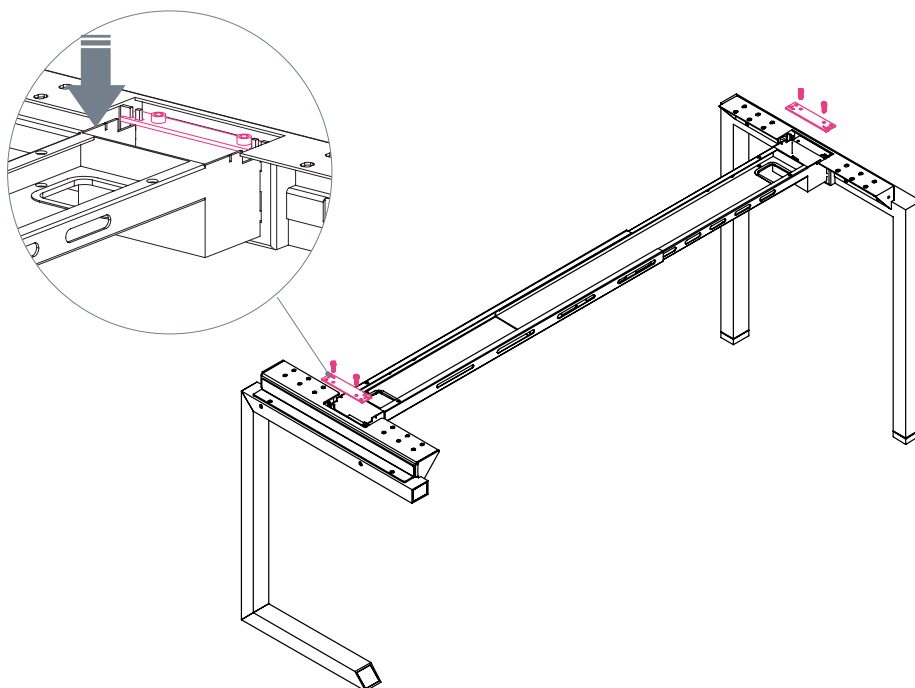

9A FREE-STANDING RETURN ASSEMBLY

NOTE: If attaching return to main surface, SKIP to 10A.

Assemble return surface by securing BL24 leg and C-leg to underside of laminate surface with wood screws. Legs should be flushed with surface edges.

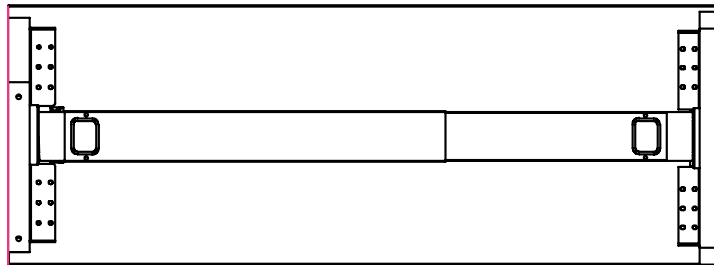
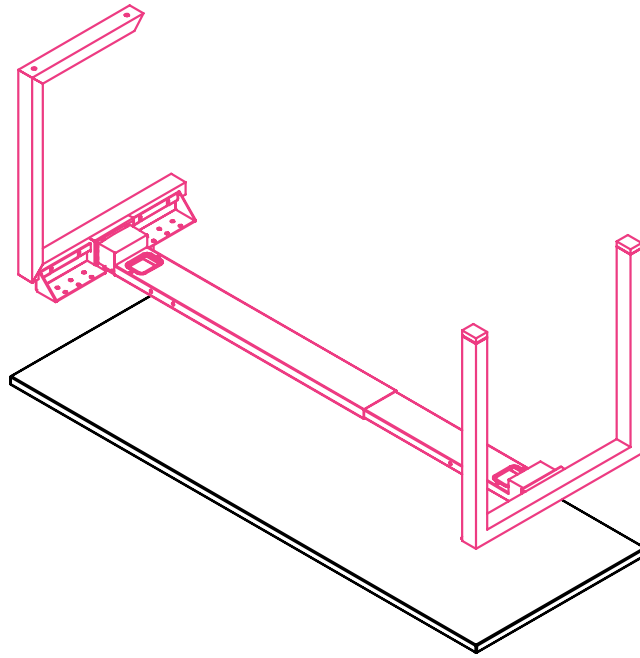

9B | ATTACH SUPPORT BAR TO MAIN SURFACE

72" OR LONGER

Center align support bar to underneath main surface and attach using wood screws. Bring desks together.

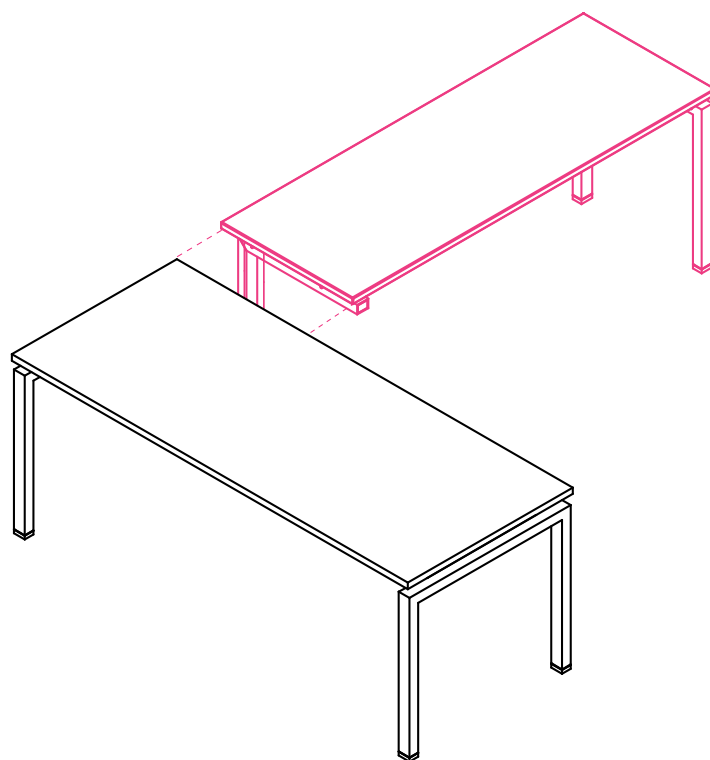
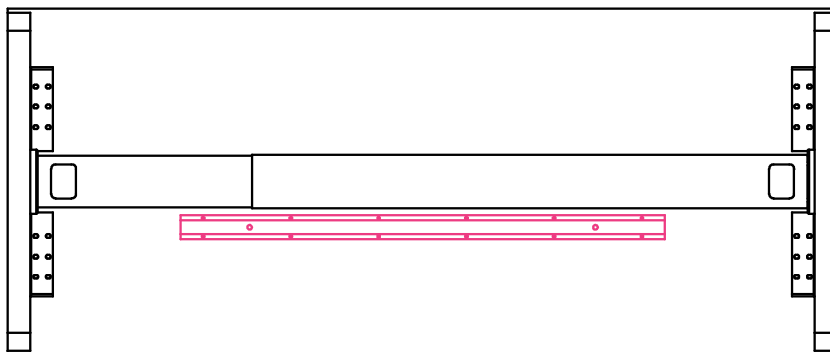

10A | ATTACHING RETURN TO MAIN SURFACE ASSEMBLY

NOTE: If assembling for free standing return, SEE 9A.

Assemble return surface by securing BL24 leg and C-leg to underside of laminate surface with wood screws. C-leg will be inset 2 inches from surface edge.

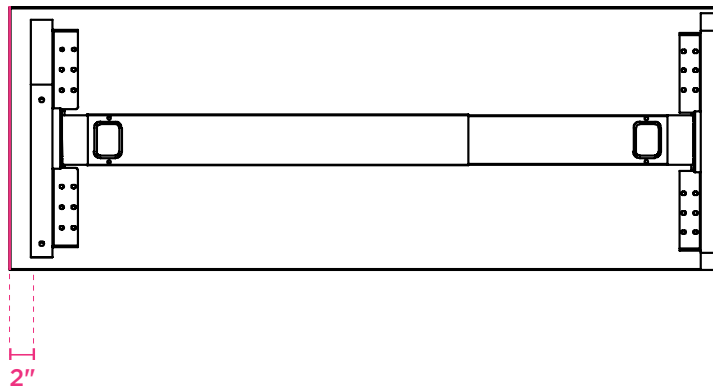
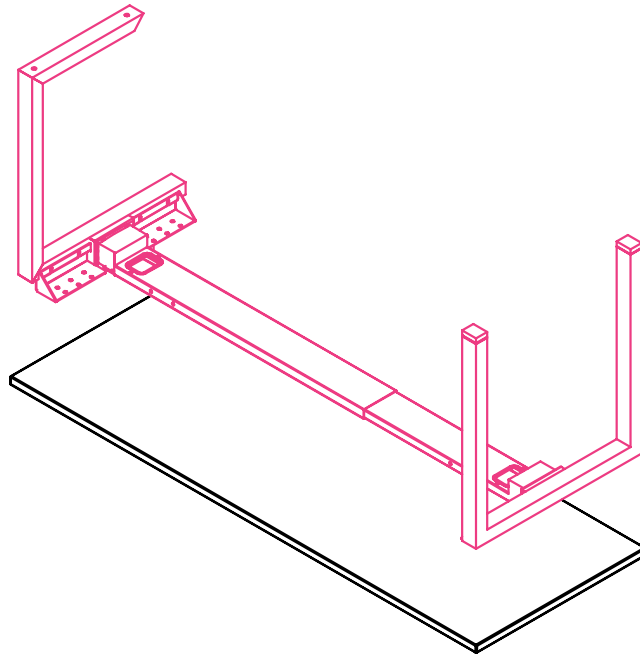

10B | ATTACH FLAT BRACKETS TO MAIN SURFACE

Attach flat brackets to main surface using wood screws. See dimensions below for bracket placement. For surfaces 72" or larger, secure support bar to center of the main surface. Insert wood screws through support bar and into underside of surface. Tighten the screw on main profile beam.

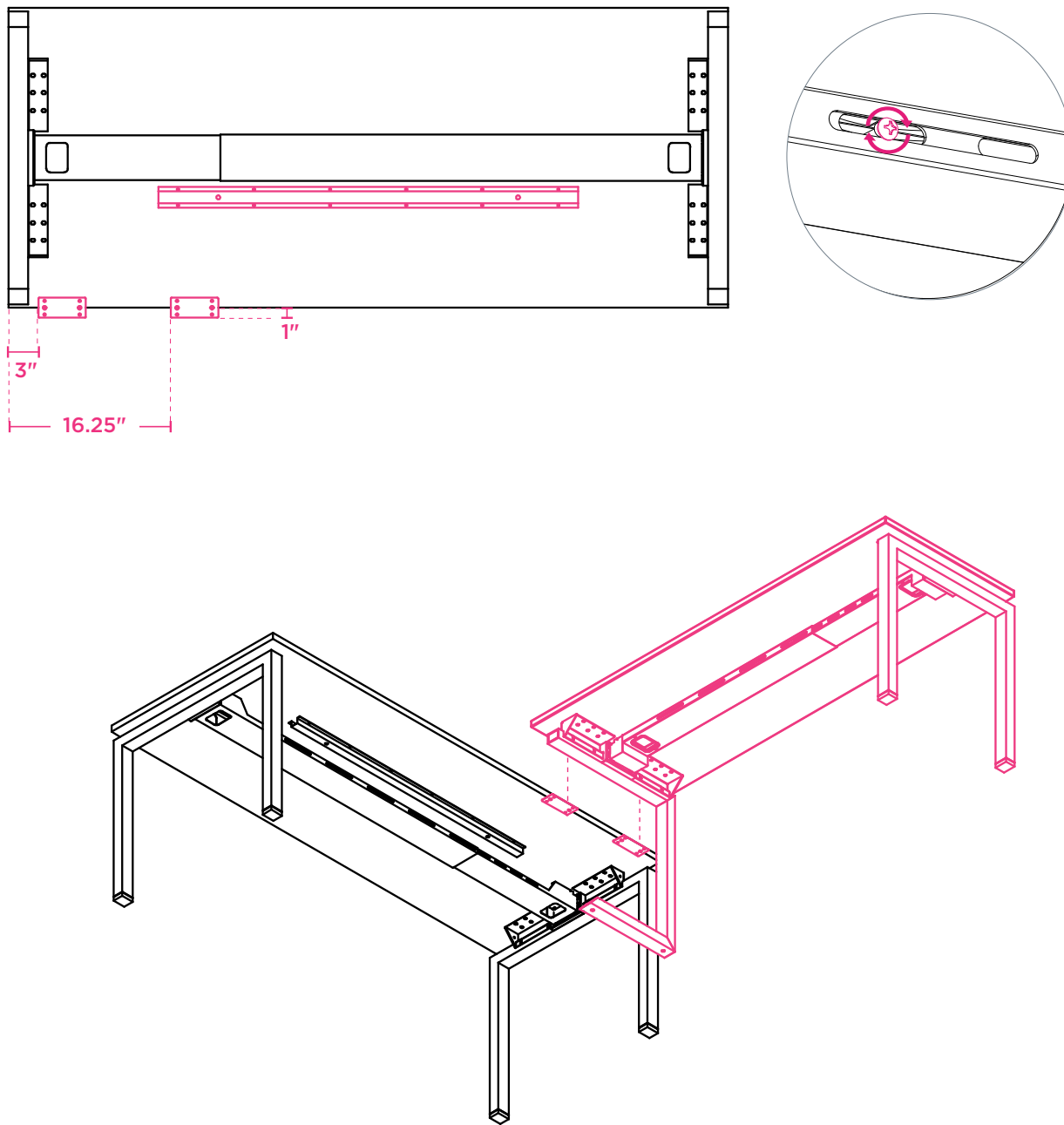

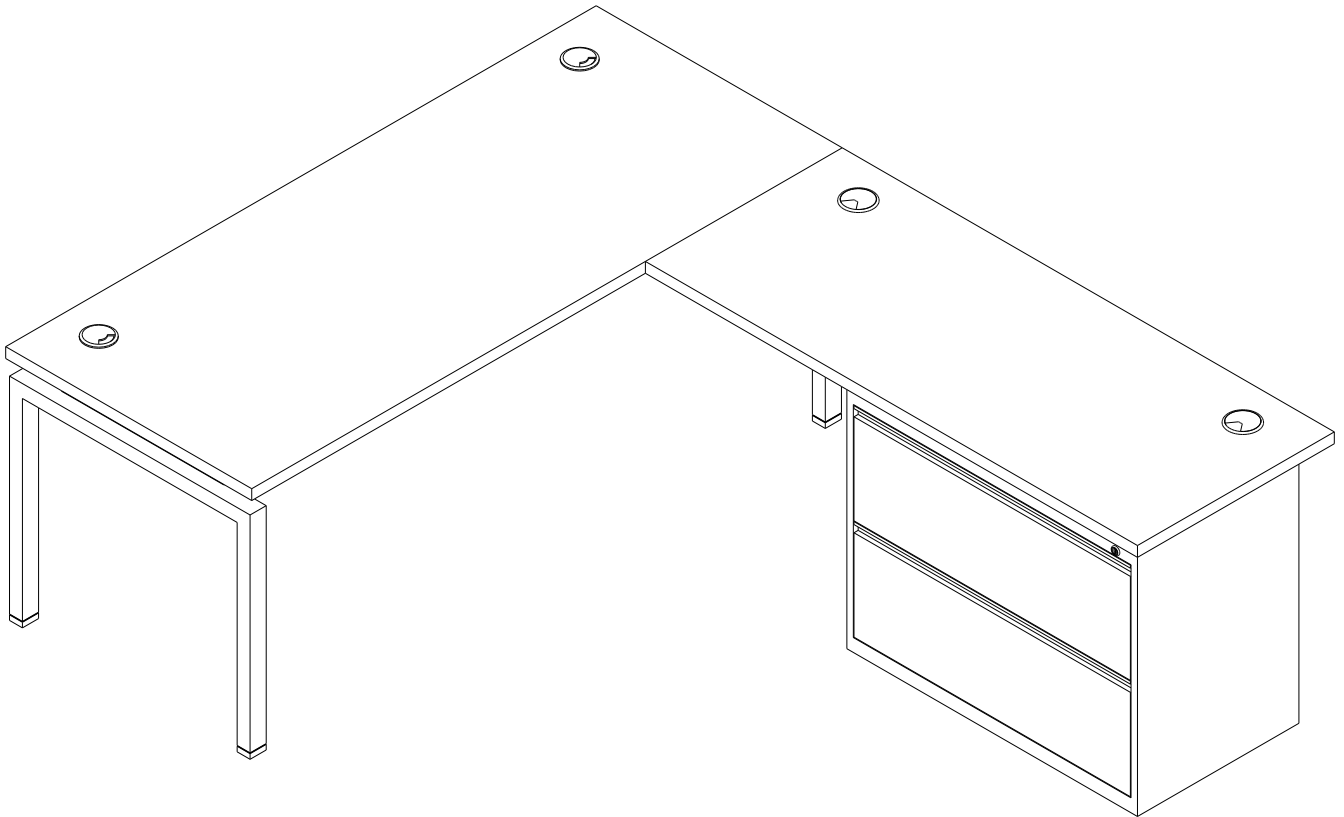











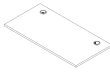

WORKSTATION WITH STEEL STORAGE

OVERVIEW

BLADE L-Shape

! All parts listed are for a L-Shape workstation with steel storage; additional parts will be needed for additional L-Shape workstations with steel storage.

PARTS LIST

CODE	QTY	DESCRIPTION	
GB3072	1	Surface 30"x72"	
GB2448	1	Return Surface 24"x60"	
BB3	1	Extra Long Beam	
	2	Lock Plate	
	4	Cap Screw	
	1	Locking Screw and Lever	
BL30	2	BLADE 30" End Leg	
	12	Wood Screws	
BASB72	2	42" Support Bar*	
	20	Wood Screws	
BFB1	2	Flat Bracket	
BLLF42	1	Steel Lateral Storage	

*Support bars will be added to surfaces 72" and longer.

1 | JOIN MAIN SURFACE END LEGS WITH BEAM

Insert beam tabs into leg brackets. Guide beam tabs into bracket holes, ensuring that there is not a gap between the beam and legs. Using a rubber mallet, hammer the beam to lock in place.

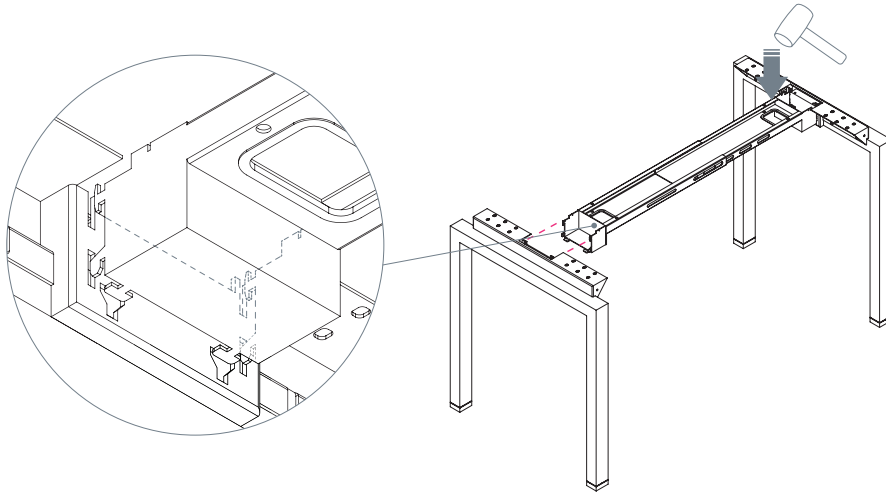

2 | BOLT DOWN BEAM-TO-LEG LOCK PLATE

Note: The beam lock plates will not fit if there is a gap between the beam and the leg.

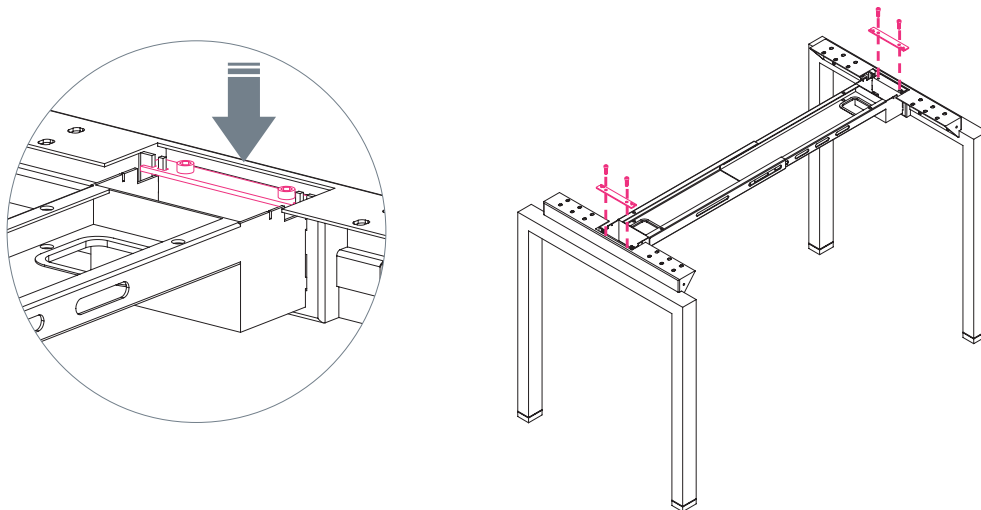

3 | MEASURE AND ADJUST BEAM WIDTH

Measure from end leg to end leg until you find the approximate width of the work surface. Insert the screw through the overlapping beam slots and into the locking screw and lever. Slightly tighten the screw. **DO NOT** fully tighten. Insert beam grommet covers.

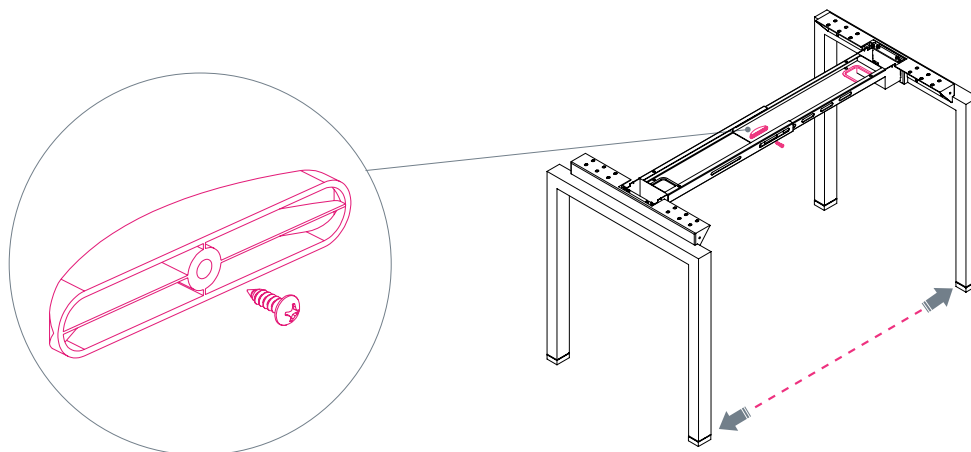

4 | SECURE THE MAIN SURFACE

Position the surface on the desk frame. Align the outer sides of the surface flush and parallel with the outer sides of the end legs, adjust if not flushed. Insert wood screws into the leg brackets and secure to the underside of the surface.

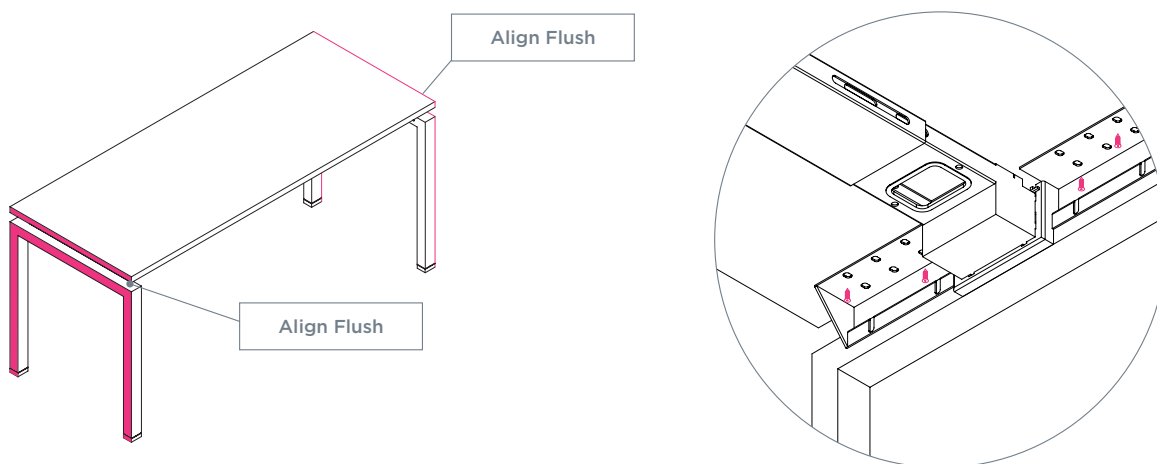

5 | PLACE STORAGE PIECE AND DESK IN POSITION

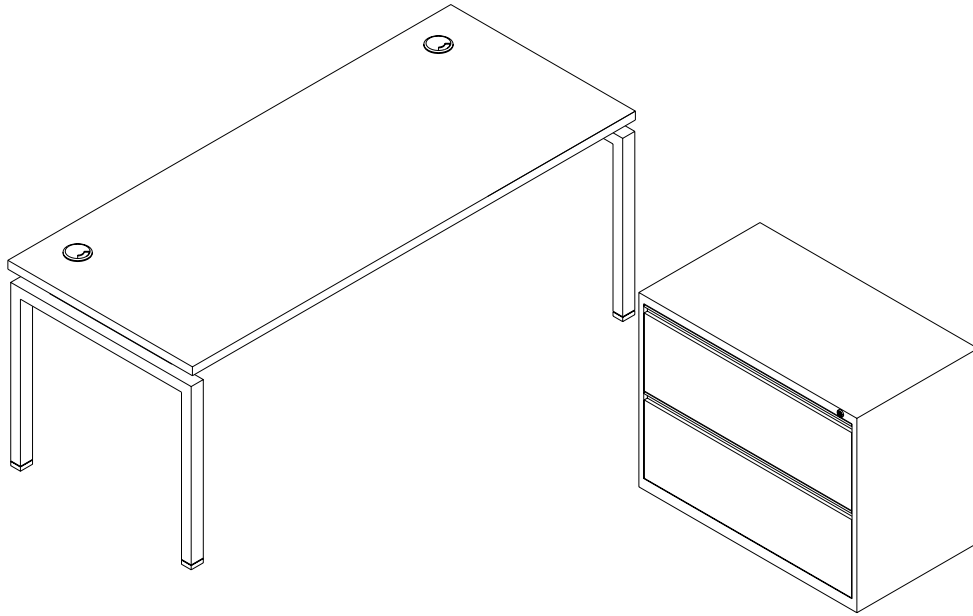

6 | SECURE FLAT BRACKETS

Secure flat plates to underside of main surface using 2 wood screws, half of bracket should extend over the edge. Align the return surface and secure flat plates using wood screws.

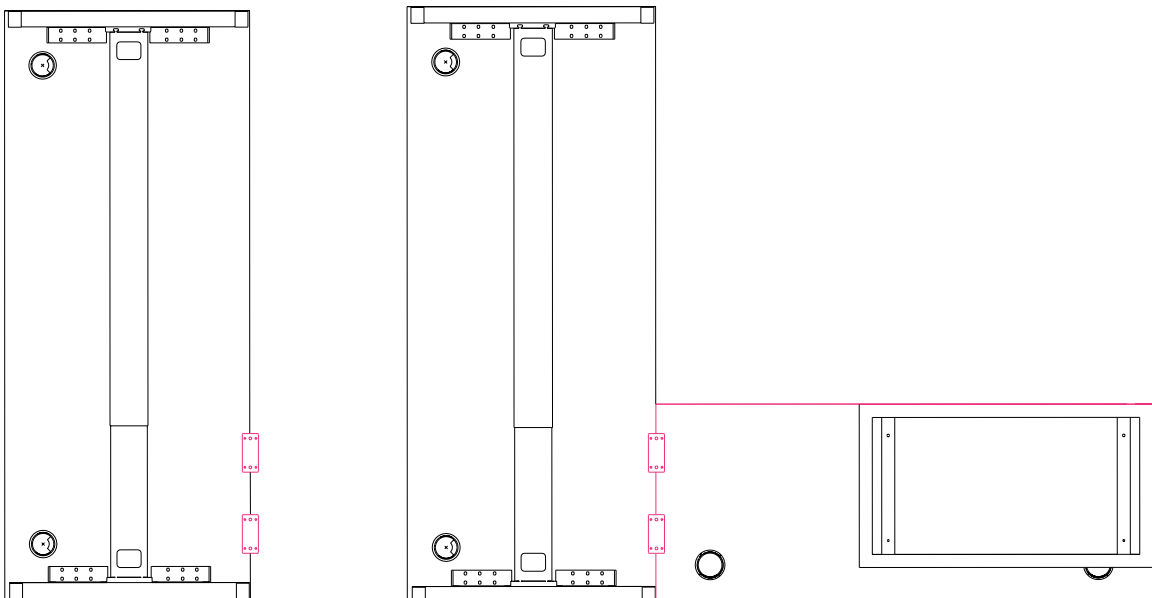

7 | SECURE SUPPORT BAR AND FINAL SCREWS

Secure support bar to center of the main surface. Insert wood screws through support bar and into underside of surface. Tighten the screw on main profile beam.

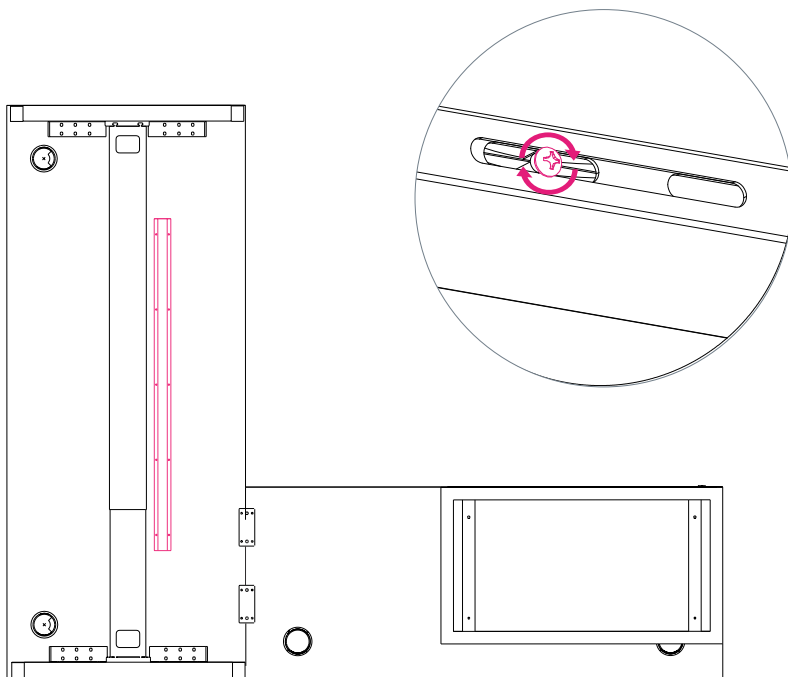

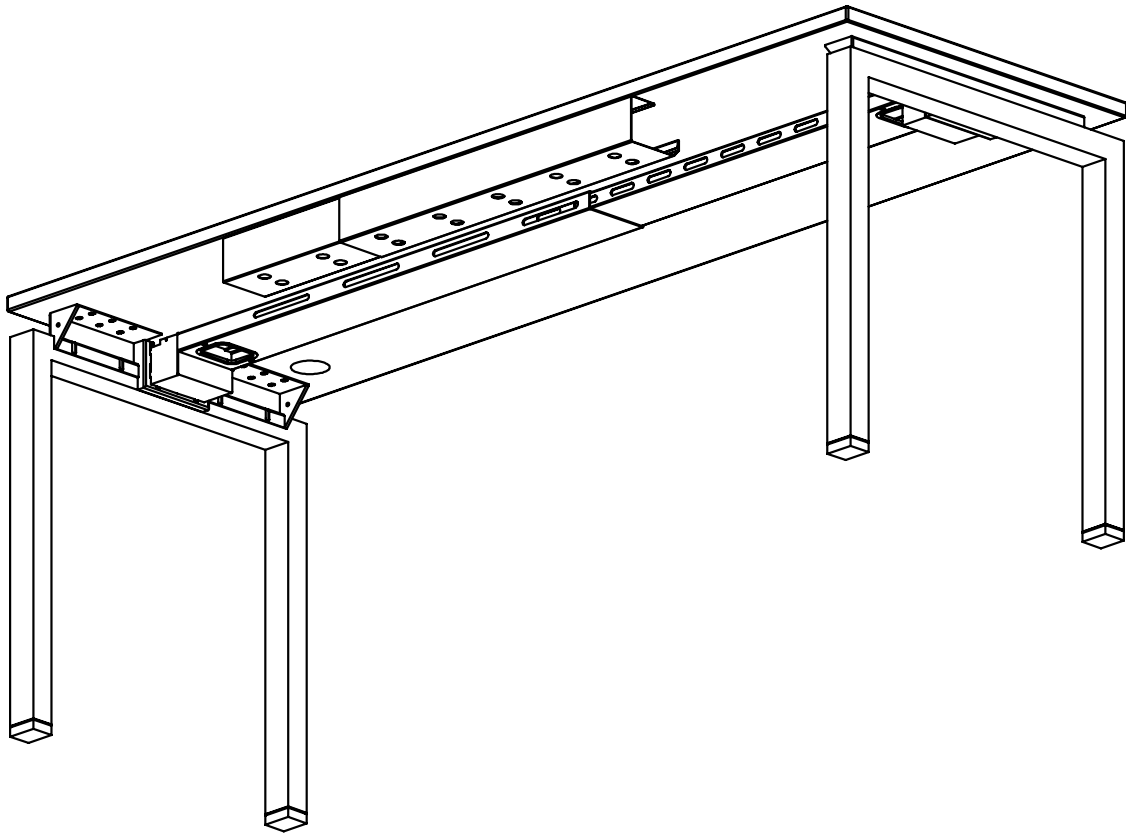

A1: SURFACE-MOUNT CABLE MANAGEMENT TRAY

OVERVIEW

BLADE L-Shape

⚠ If workstations have power, refer to BL-8 BLADE power guide.

PARTS LIST

CODE	QTY	DESCRIPTION	
BHCT	1	Surface-Mount Cable Management Tray	
	10	Wood Screws	

1 | EXTEND CABLE TRAY TO DESIRED LENGTH

Extension range: 25"-45".

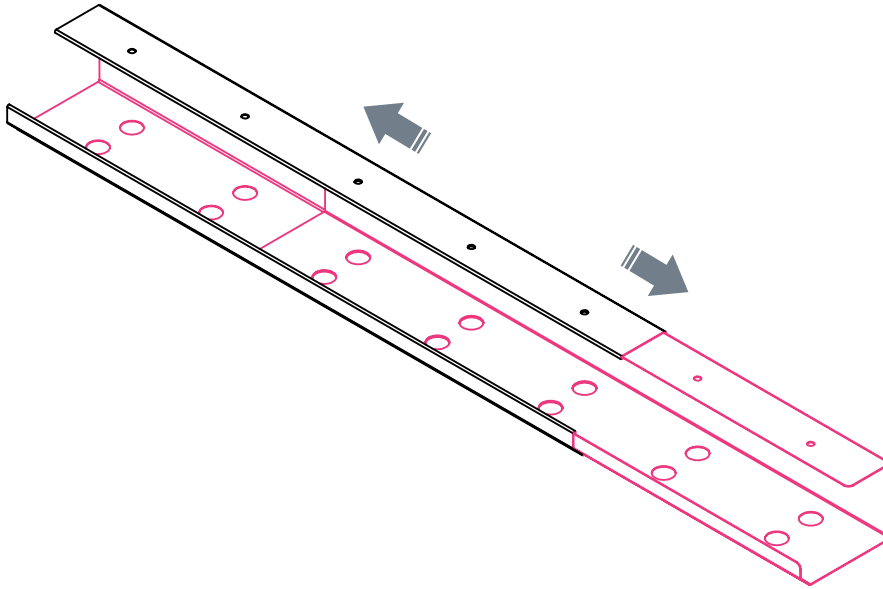

2 | ATTACH CABLE TRAY TO SURFACE

Attach cable tray using wood screws.

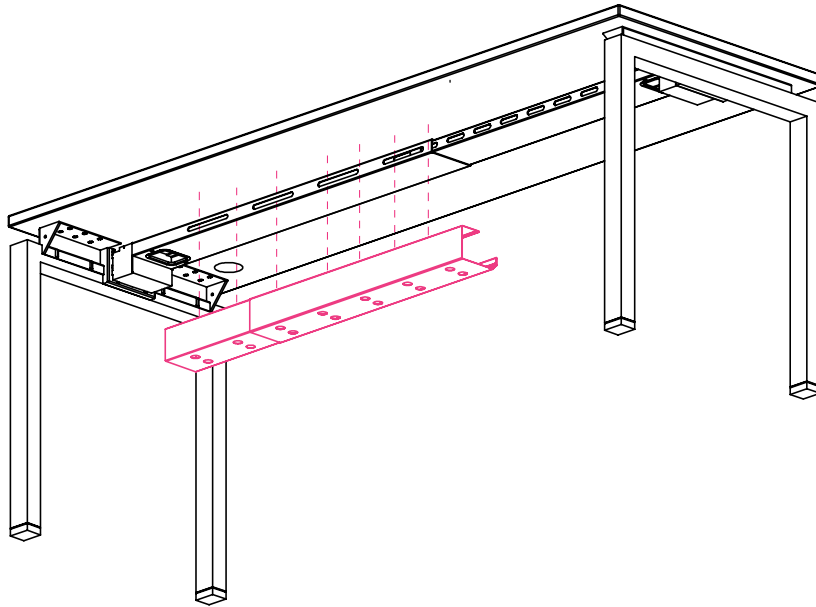

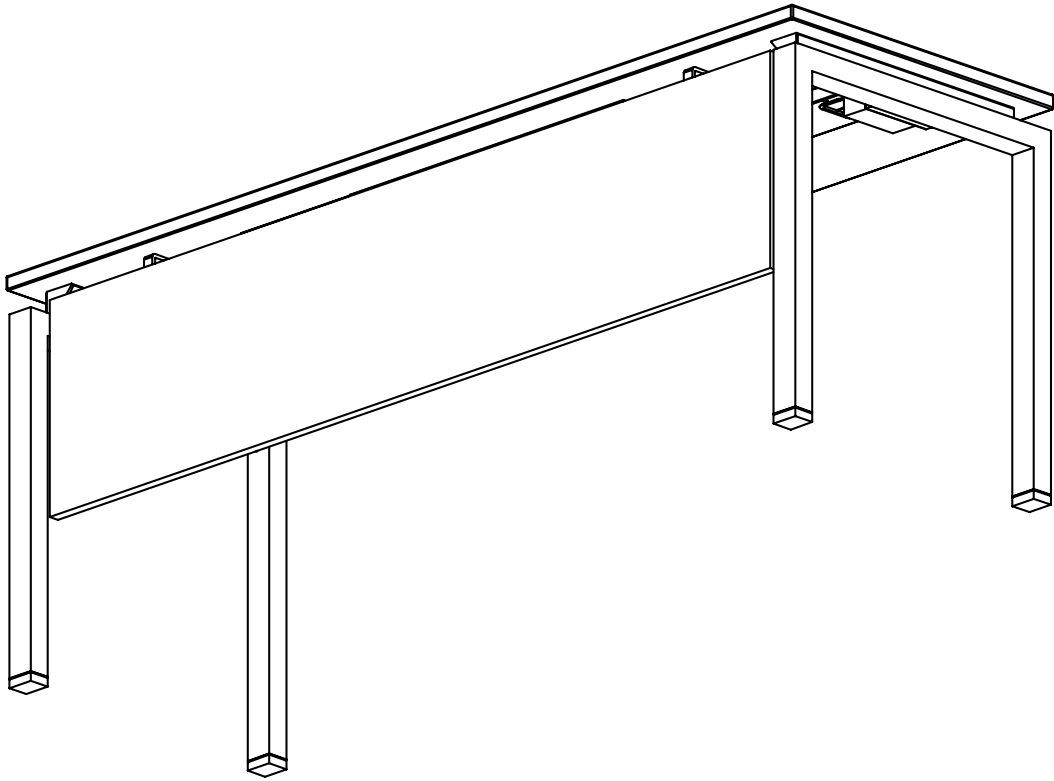





A2: MODESTY PANEL

OVERVIEW

BLADE L-Shape

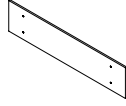
! All parts listed are for a single modesty panel; additional parts will be needed for additional modesty panels.

PARTS LIST

CODE	QTY	DESCRIPTION	
GLMP##	1	Laminate Modesty Panel*	
	4	Machine Screws	
BMPBFB	2	L-Brackets	
	4	Wood Screws	

*For Steel Modesty Panel: components may vary, but process is similar.

1 | SECURE BRACKETS TO MODESTY PANEL

Connect the BMPBFB bracket to the modesty panel using screws.
Secure tightly.

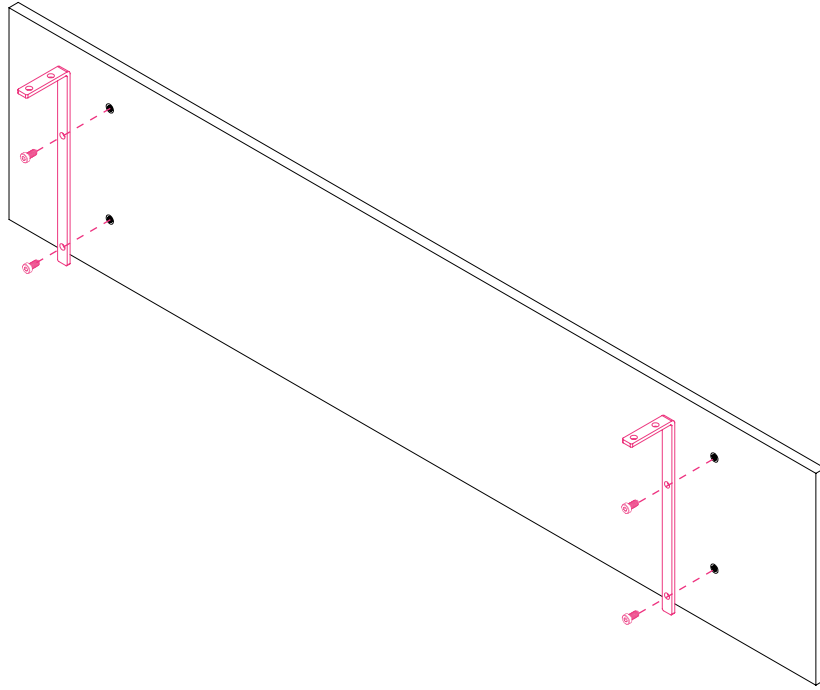

2 | ATTACH MODESTY PANEL TO SURFACE

Attach modesty panel to surface using wood screws provided with brackets. Panel will be center aligned and flushed with back of surface.

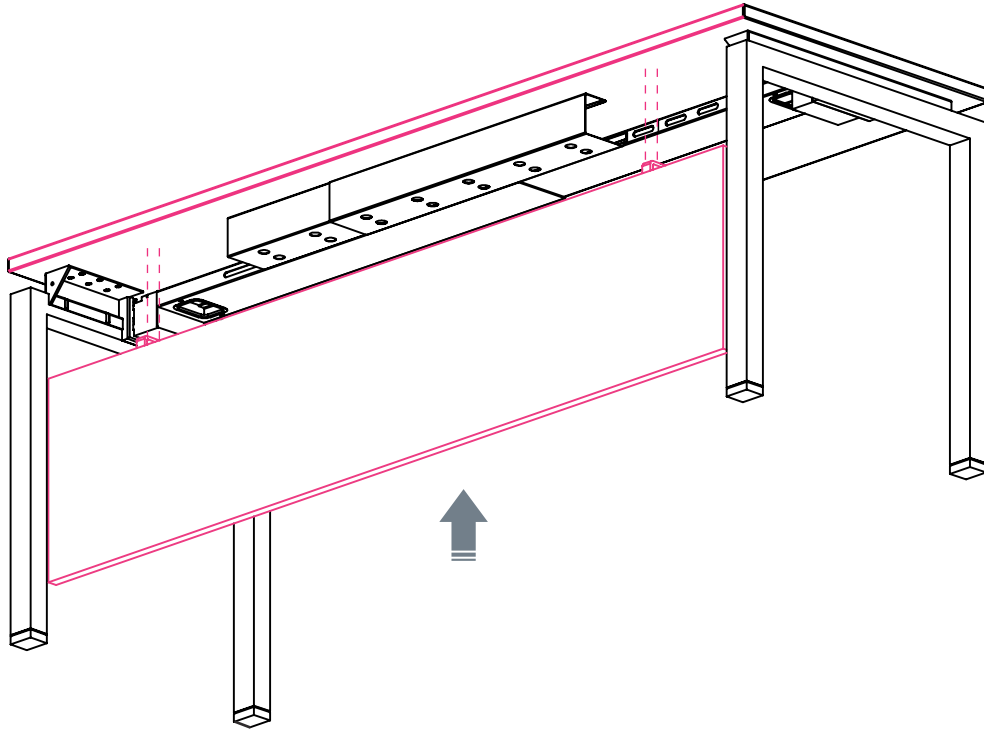

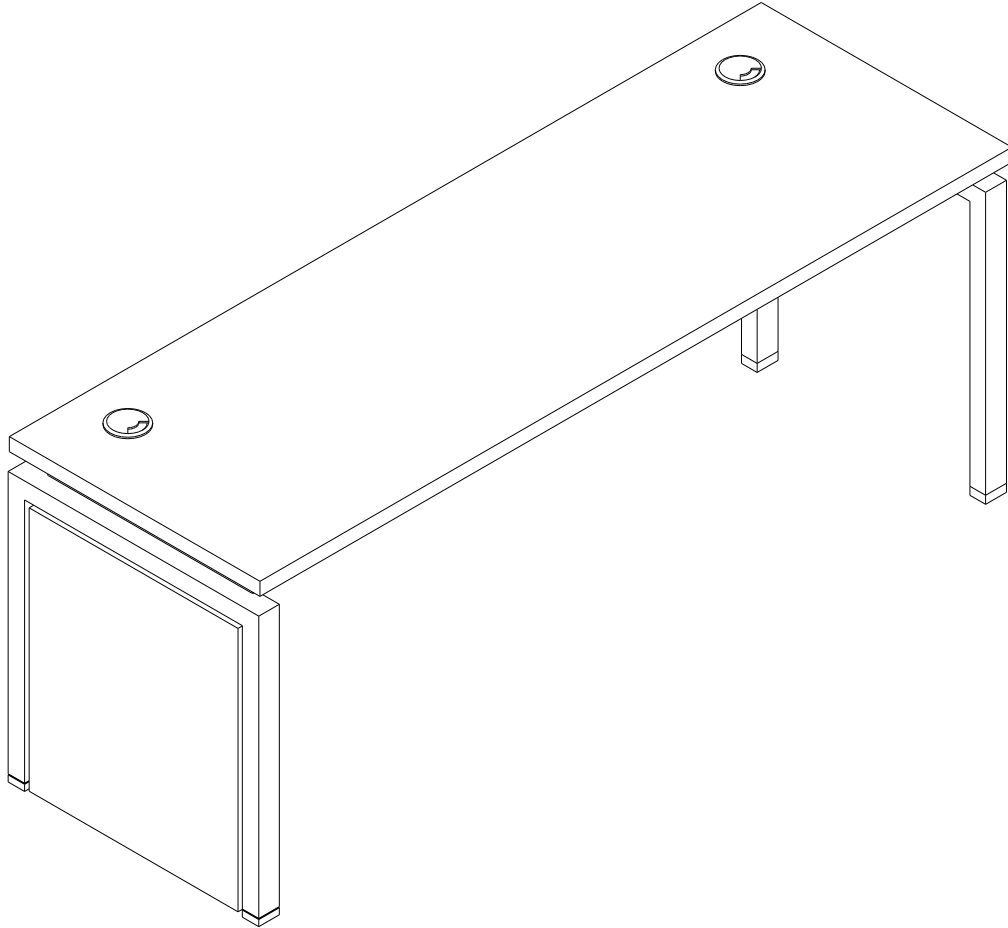

A3: LAMINATE INSET END PANELS

OVERVIEW

BLADE L-Shape

! All parts listed are for a single panel; additional parts will be needed for additional panels.

PARTS LIST

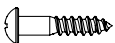
CODE	QTY	DESCRIPTION	
GBEP##	1	Laminate Inset End Panel	
LEPBL1	4	End Panel T-Bracket	
	8	Self-Tapping Screws	
	8	Wood Screws	

1 | SECURE BRACKET TO END LEGS

Attach 4 brackets to each BLADE end leg using the self-tapping screws.

1. Inset-The back of the bracket will align flush with edge of leg.
2. Flush-Back of bracket will be $9/16$ " from edge back edge of leg.

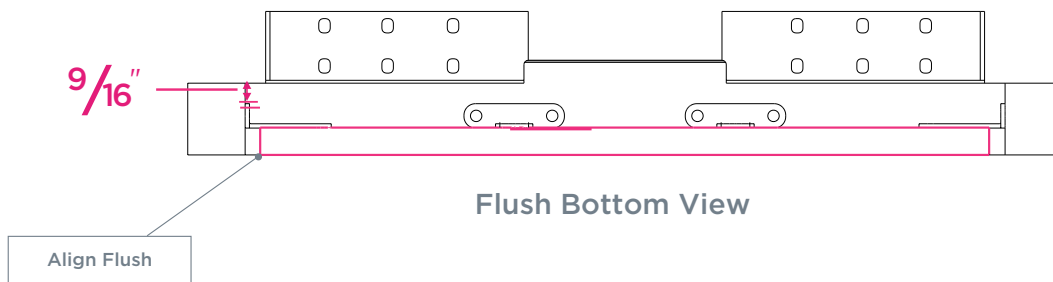
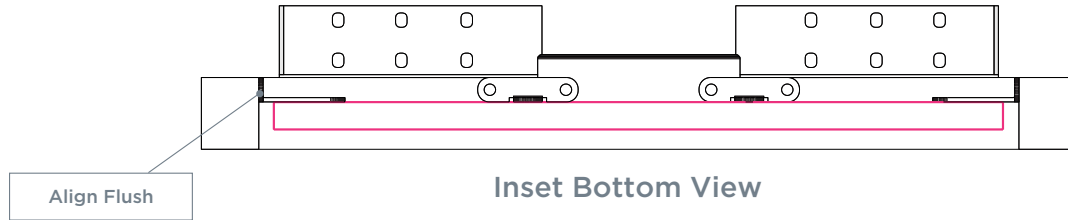

2 | ATTACH END PANEL

Slide end panels into place and adjust until flush with bracket. Use 2 wood screws to secure panel to each bracket.

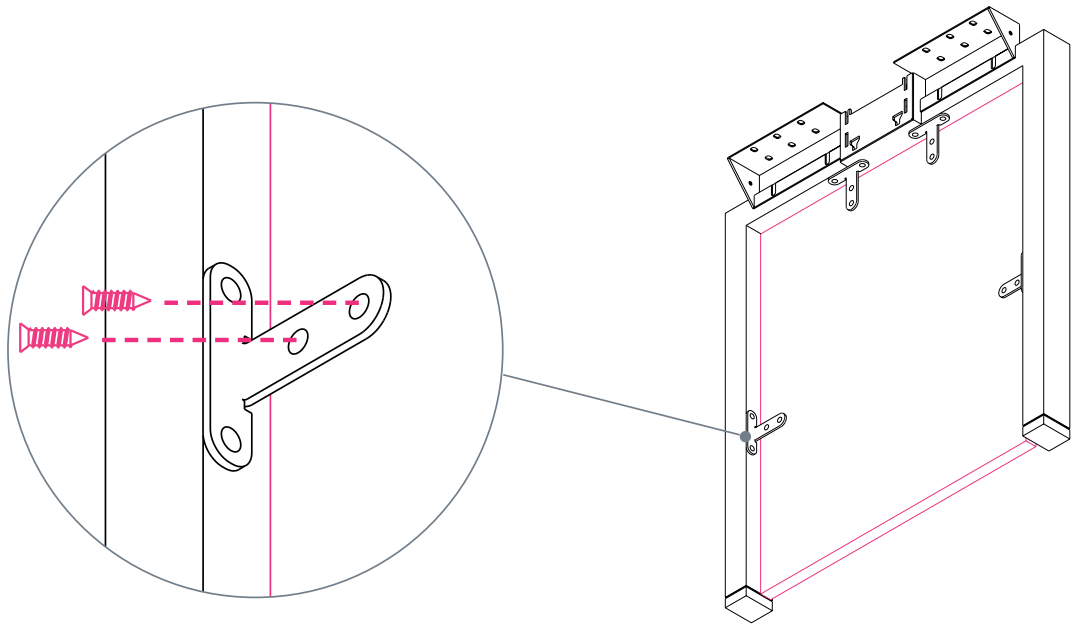

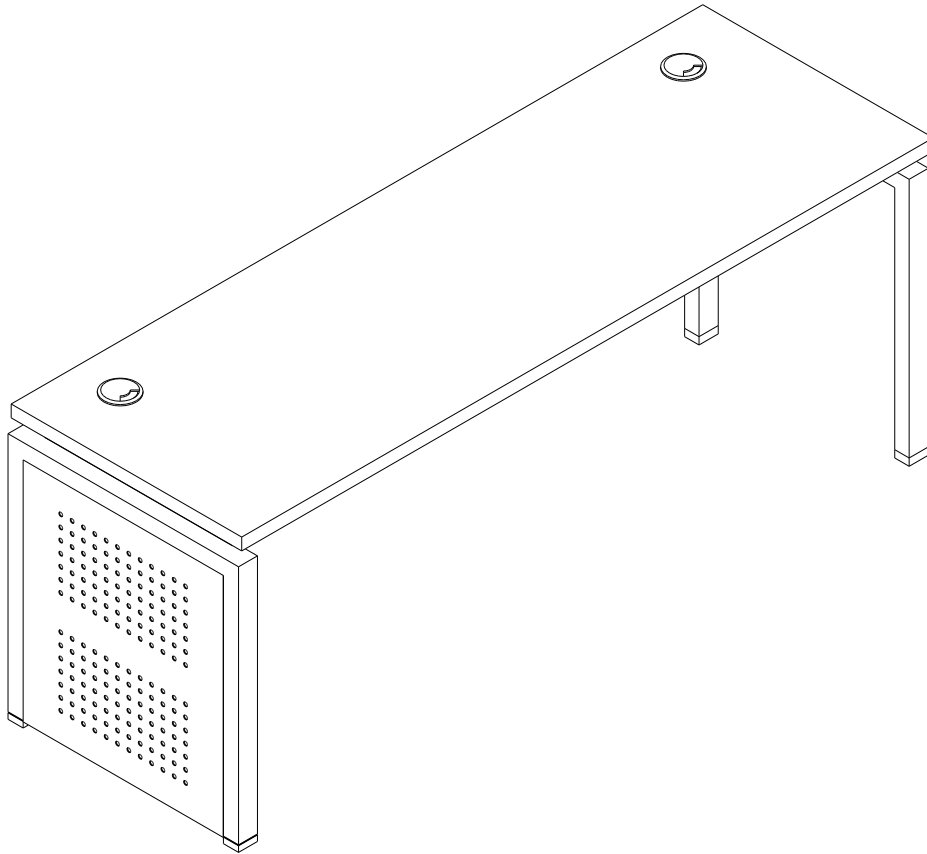



A4: STEEL INSET END PANELS

OVERVIEW

BLADE L-Shape

! All parts listed are for a steel inset end panel; additional parts will be needed for additional steel inset end panels.

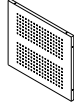
PARTS LIST

CODE	QTY	DESCRIPTION	
BEP##	1	Steel Inset End Panel	
	6	Self-Tapping Screws	

1 | SECURE PANELS TO END LEGS

Slide the end panel into place and adjust until either flush with outside of leg or slightly recessed.

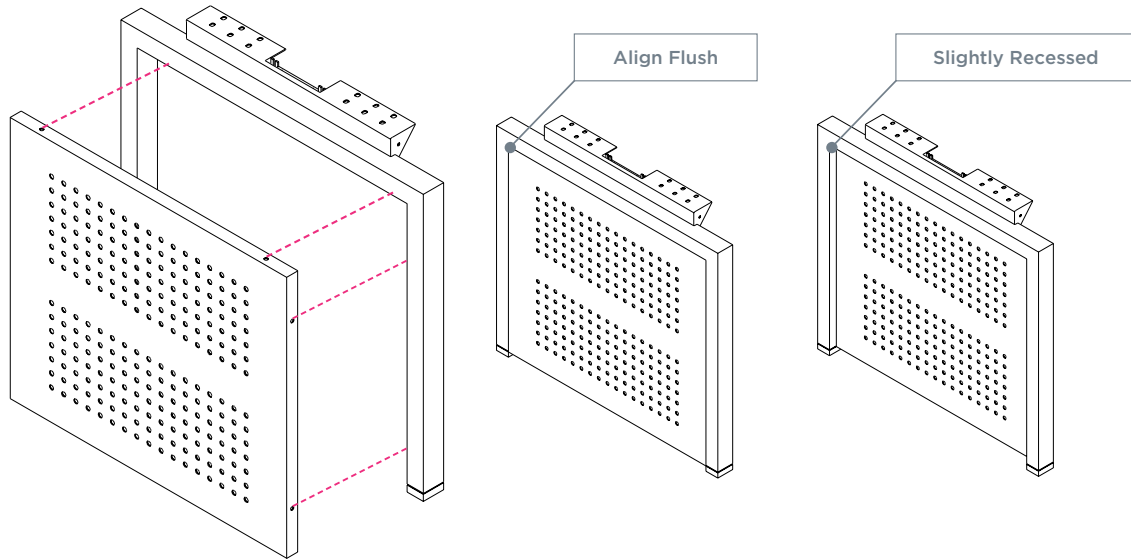

2 | ATTACH END PANEL

Use 4-6 self-tapping screws to secure panel to each leg.

