

## Focus Pod

---

General Installation Guide

## 1 | Secure Connecting Steel Dowels to Panels

Insert connecting steel dowel plate into marking hole and insert four  $\frac{3}{4}$ " screws through flat plate to secure. Repeat step for all 4 steel dowels.

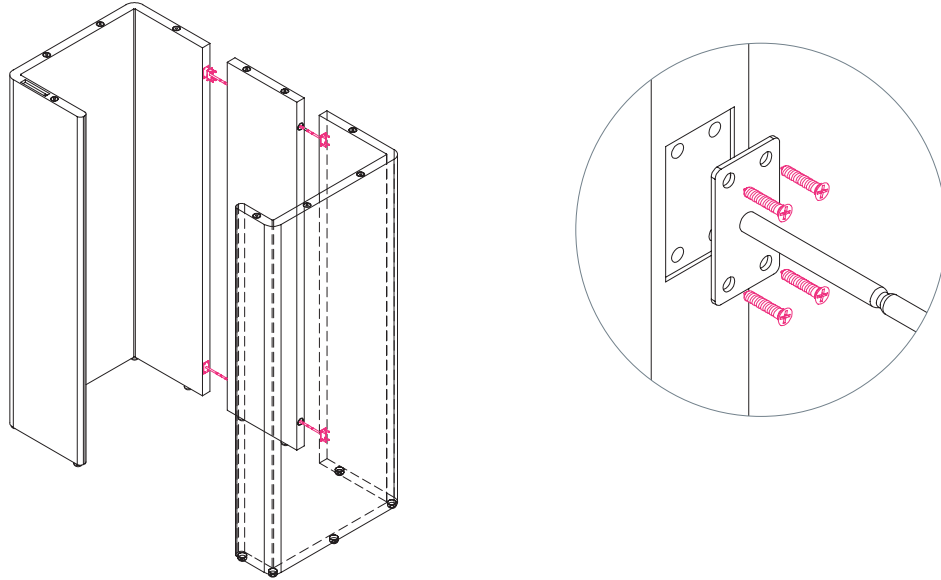

## 2 | Insert Steel Dowels into Joint Holes

Line up steel dowels so that they are flush with joint holes on adjacent panel. Push against outer walls of pod until panels are flushed.

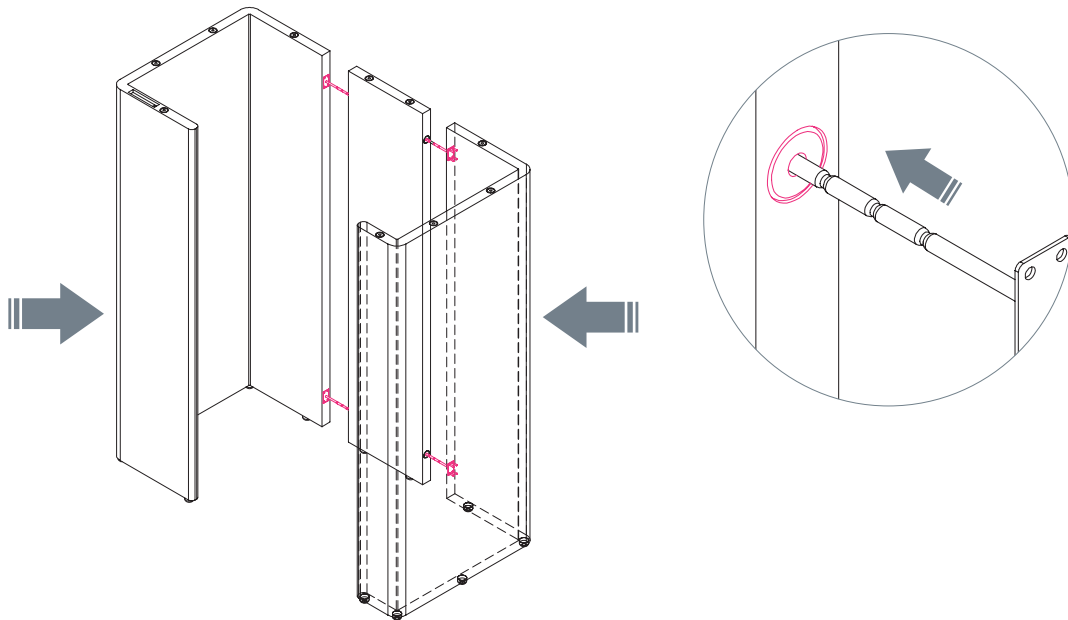

### 3 | Secure Panels

Adjust panel bracket, attached to bottom of panel, so open end fits around stand-alone bolt on bottom of adjacent panel.

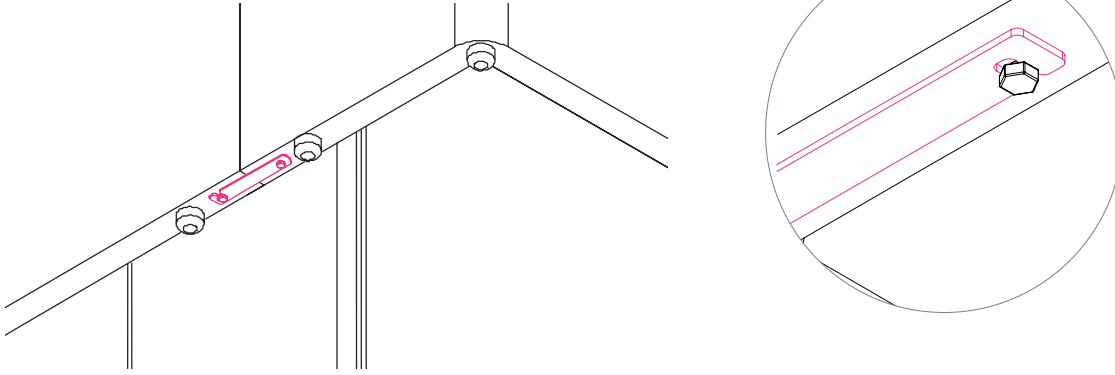

### 4 | Connect Main Power

Assemble connector joint by securing male and female halves together and secure with connector clips on top and bottom of assembly.

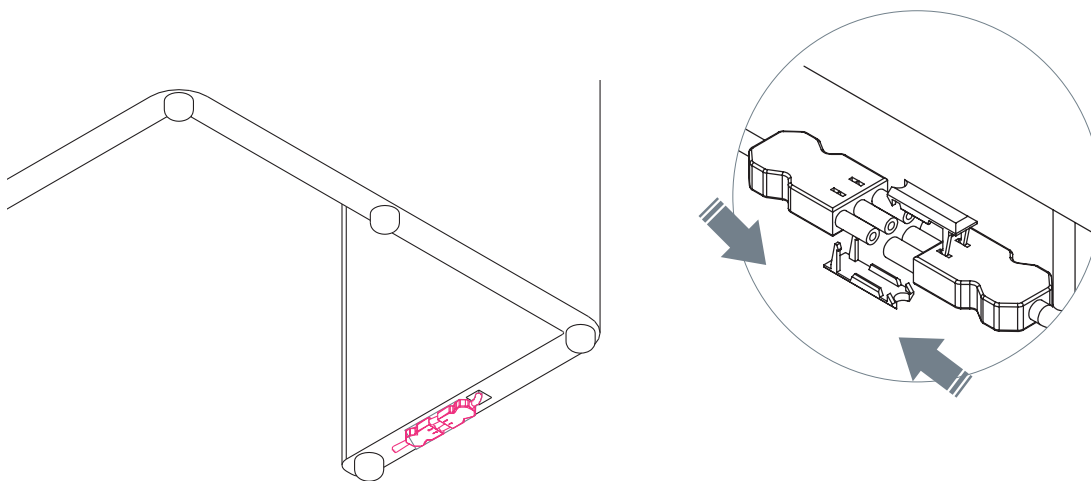

## 5| Secure Connecting Steel Dowels to Top Panel

Insert connecting steel dowel plate into marking hole on bottom side of top panel and insert four  $\frac{3}{4}$ " screws through flat plate to secure. Repeat step for all 10 steel dowels.

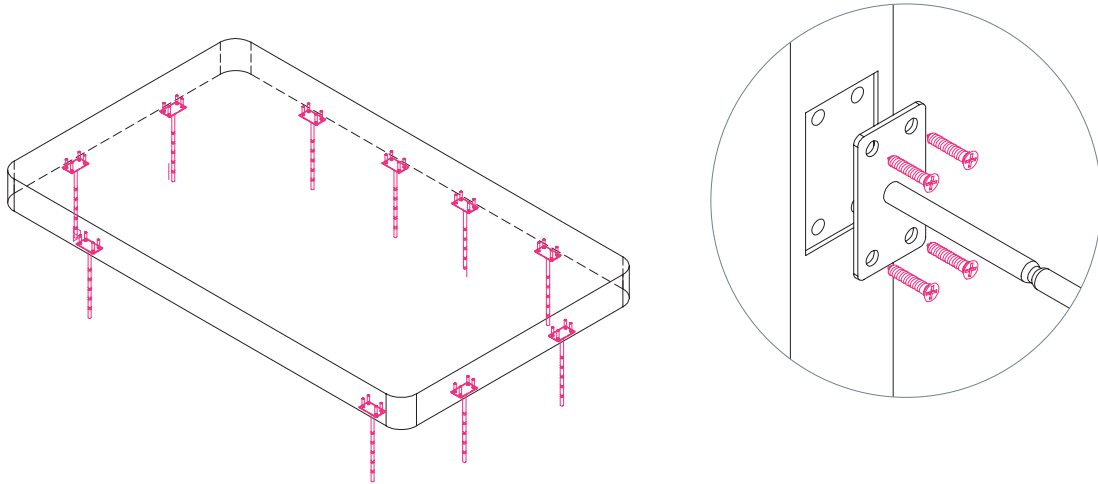

## 6 | Connect Power to Top Panel

Assemble connector joint by securing male and female halves together and secure with connector clips to top and bottom of assembly. Once connected, tuck completed assembly into slot at top of side panel.

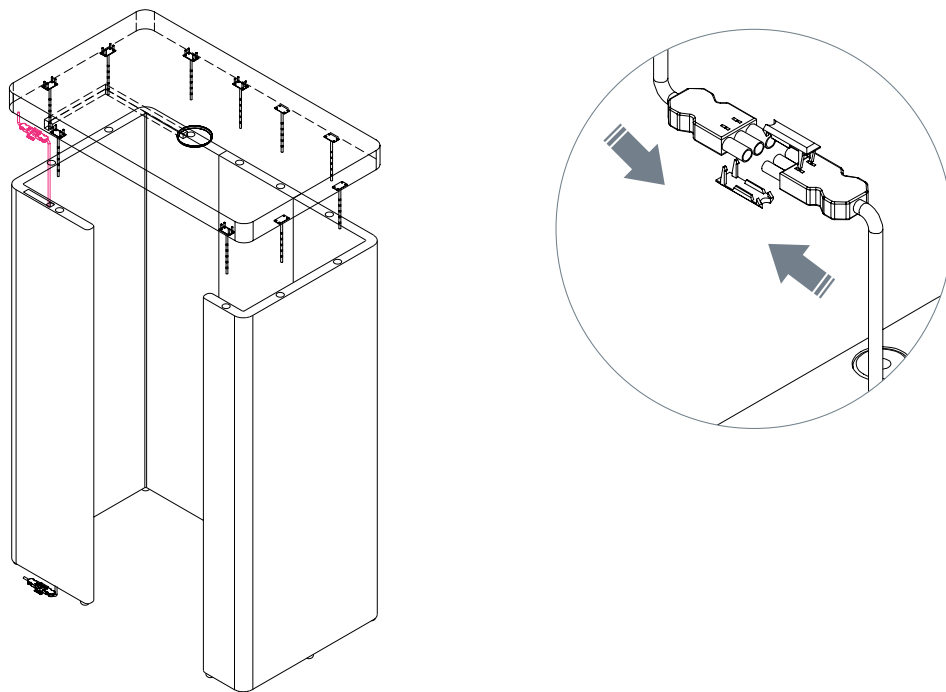

## 7 | Secure Top Panel

Line up steel dowels so they are flush with joint holes on adjacent panel. Push against outer walls of pod until panels are flushed.

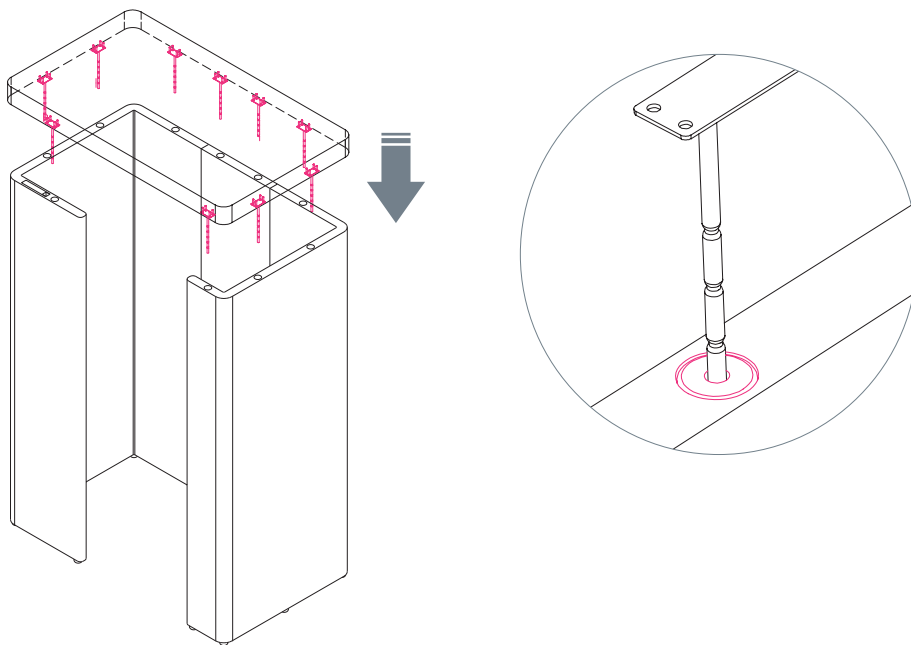

## 8 | Secure Leg to Table

Secure 4 screws through pre-drilled table base holes and into bottom of table surface.

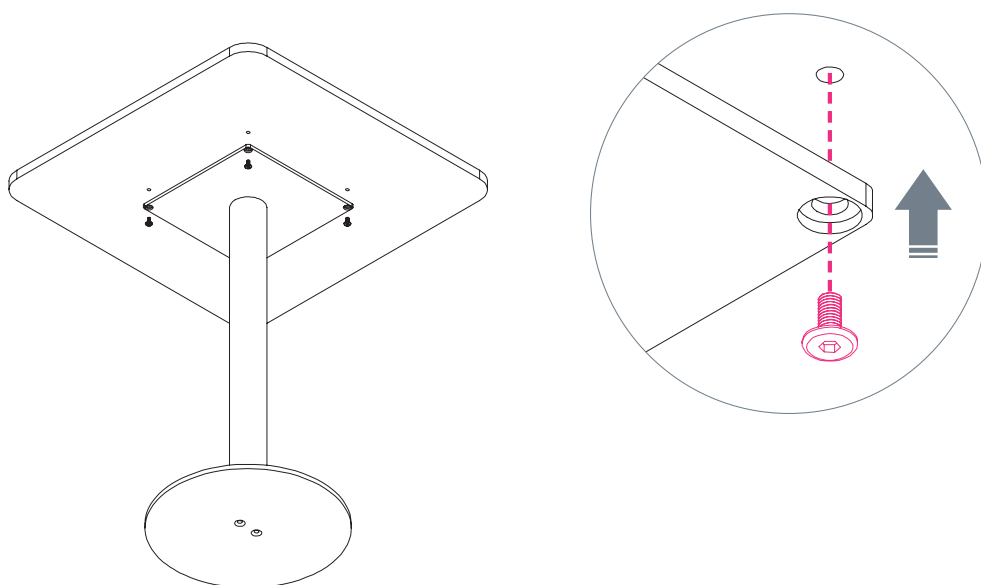

## 9| Place Seats Inside Pod

Tilt seat at a 45 degree angle. Slide into pod while tilting seat back so seat sits flat on floor.

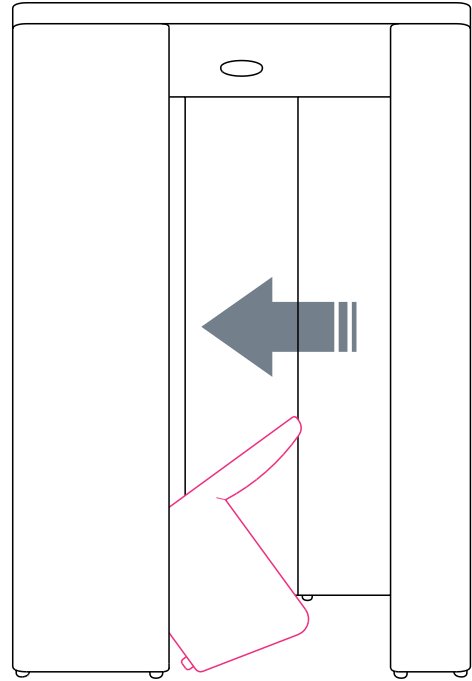
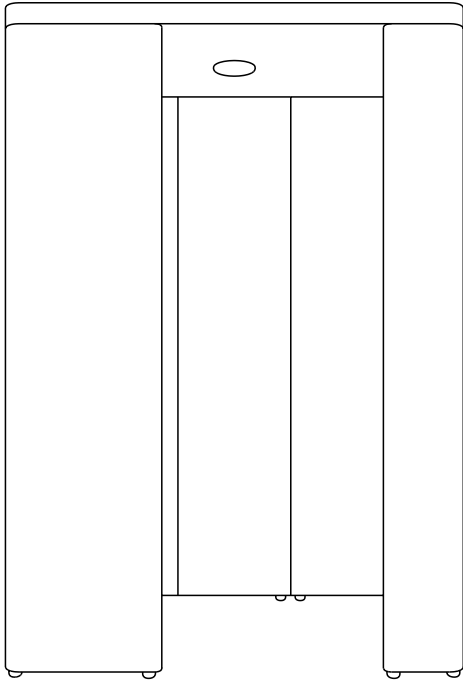

## 10 | Position Table inside Pod

