

4-Person Open Meeting Pod

1 | Measure to Approximate Width

Measure 85" from outer edge of pod of 78.7" from inner wall of pod to find approximate width. Once positioned, roof panel may be installed.

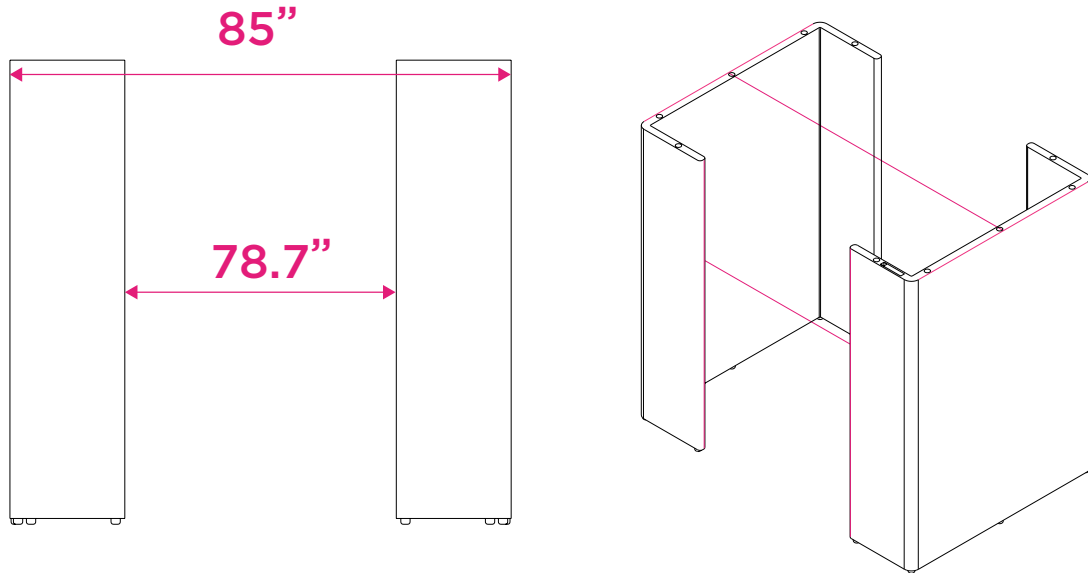

2 | Secure Connecting Steel Dowels to Top Panel

Insert connecting steel dowel plate into marking hole on bottom side of top panel and insert four $\frac{3}{4}$ " screws through flat plate to secure. Repeat step for all 10 steel dowels.

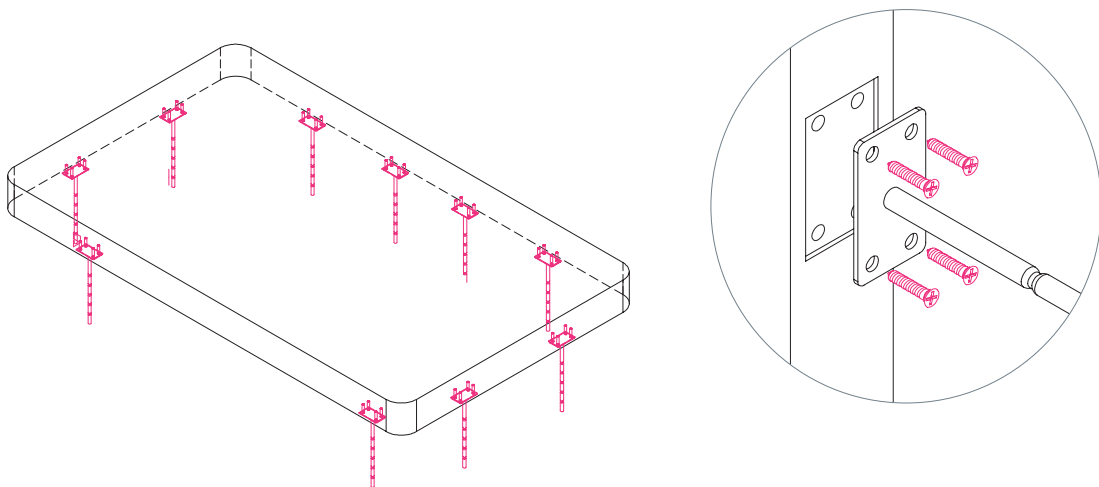

3 | Connect Main Power

Assemble connector joint by securing male and female halves together and secure with connector clips on top and bottom of assembly.

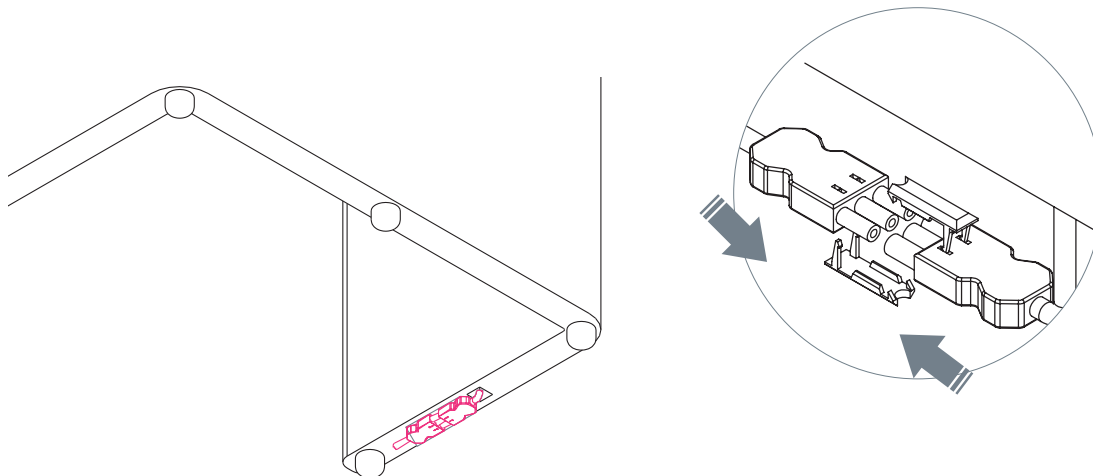

4 | Connect Power to Top Panel

Assemble connector joint by securing male and female halves together and secure with connector clips on top and bottom of assembly. Once connected, tuck completed assembly into slot at top of side panel.

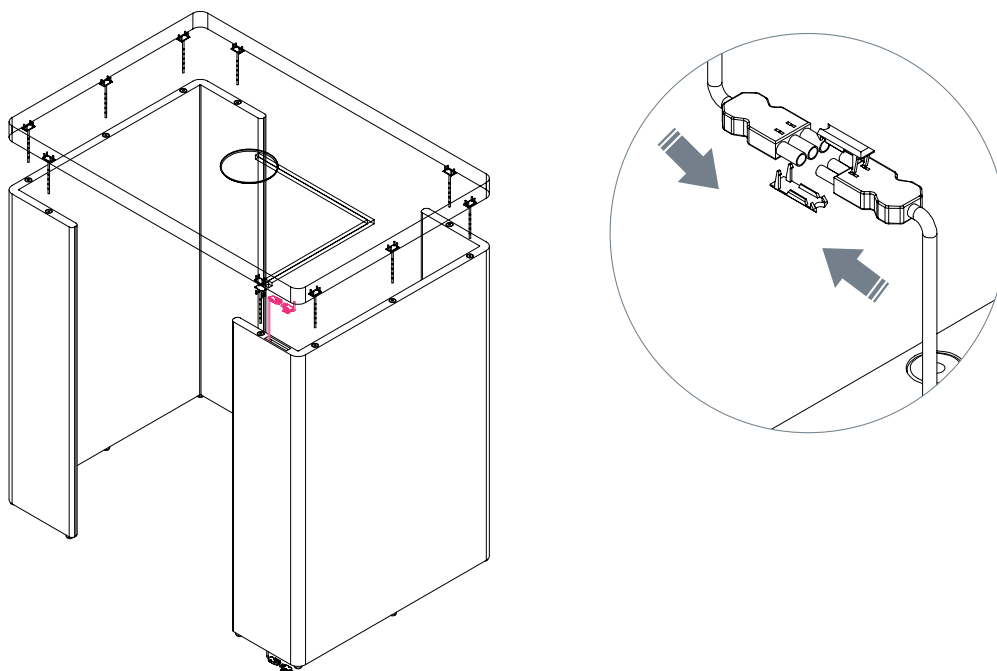

5 | Secure Top Panel

Line up steel dowels so they are flush with joint holes on adjacent panel. Push against outer walls of pod until panels are flushed.

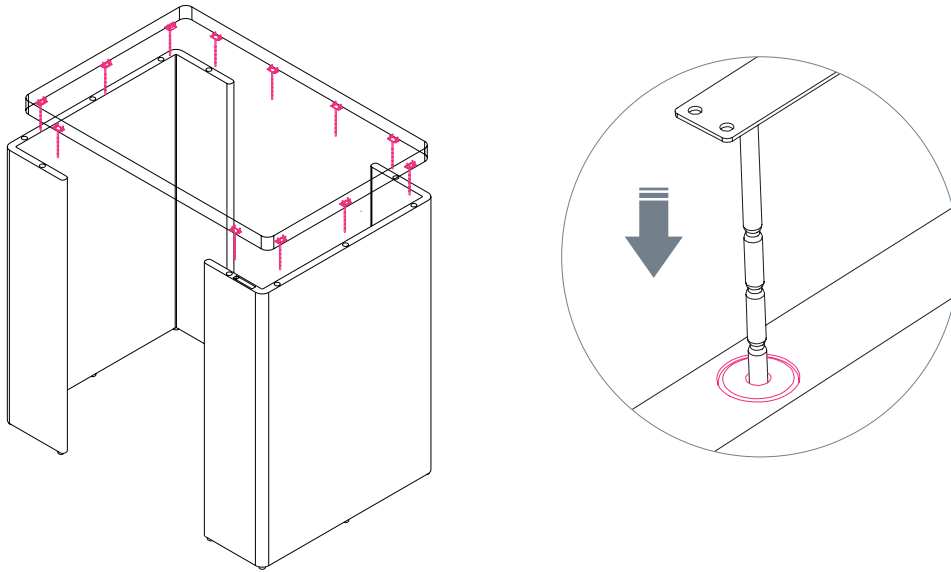

6 | Secure Legs to Table

Secure 4 screws through pre-drilled holes of each table base and into bottom of table surface.

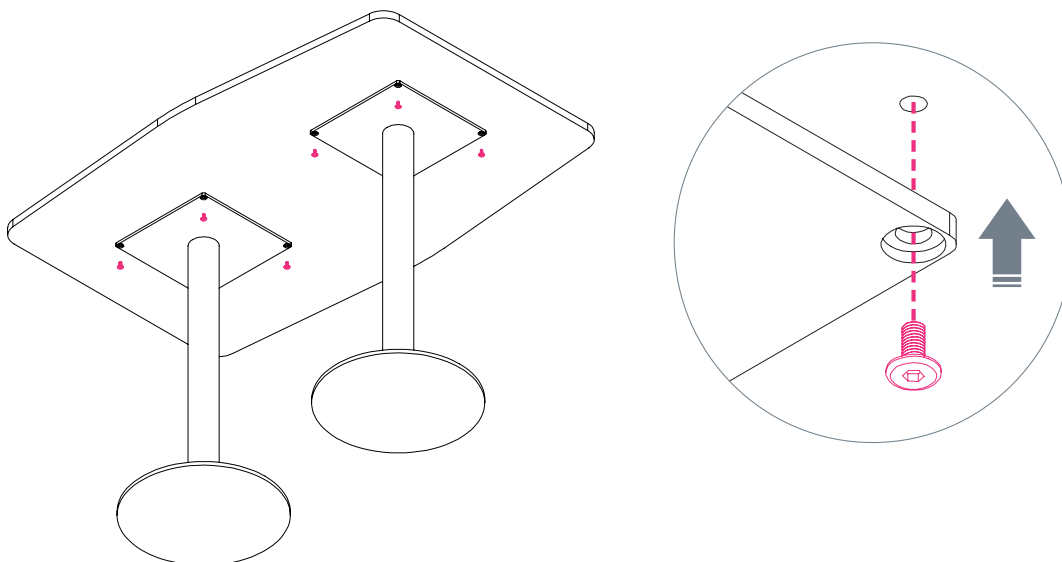

7 | Place Seats Inside Pod

Tilt seat at a 45 degree angle. Slide into pod while tilting seat back so seat sits flat on floor. Repeat for other side.

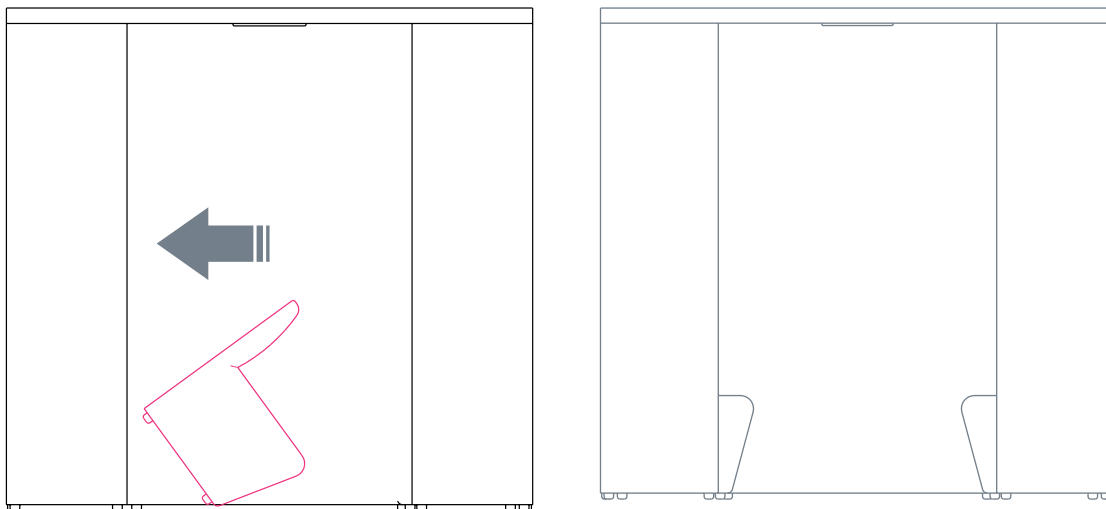

8 | Place Table Inside Pod

