

TEXAN SERIES ODK COMPONENTS

PRODUCT
16" Reversible Access Door
Item No. TEX-16SD

DESCRIPTION
16" Texan Series Reversible Door for Left or Right Swing
Works w/Propane Tanks, Trash Bins, Utility Access

PRODUCT DIMENSIONS
Product Size: 16-1/4" WIDTH x 20-1/2" HEIGHT x 1-3/4" DEPTH
Cut-Out Size: 14-1/2" WIDTH x 19" HEIGHT x 1-3/4" DEPTH

SPECIFICATIONS
304 Stainless Steel Construction Frame, Doors & 304 SS Rod Handles

WARRANTY

- EXTERIOR FINISH -----3 YEARS
- STRUCTURE -----3 YEARS
- HANDLE-----1 YEAR

Product Dimensions

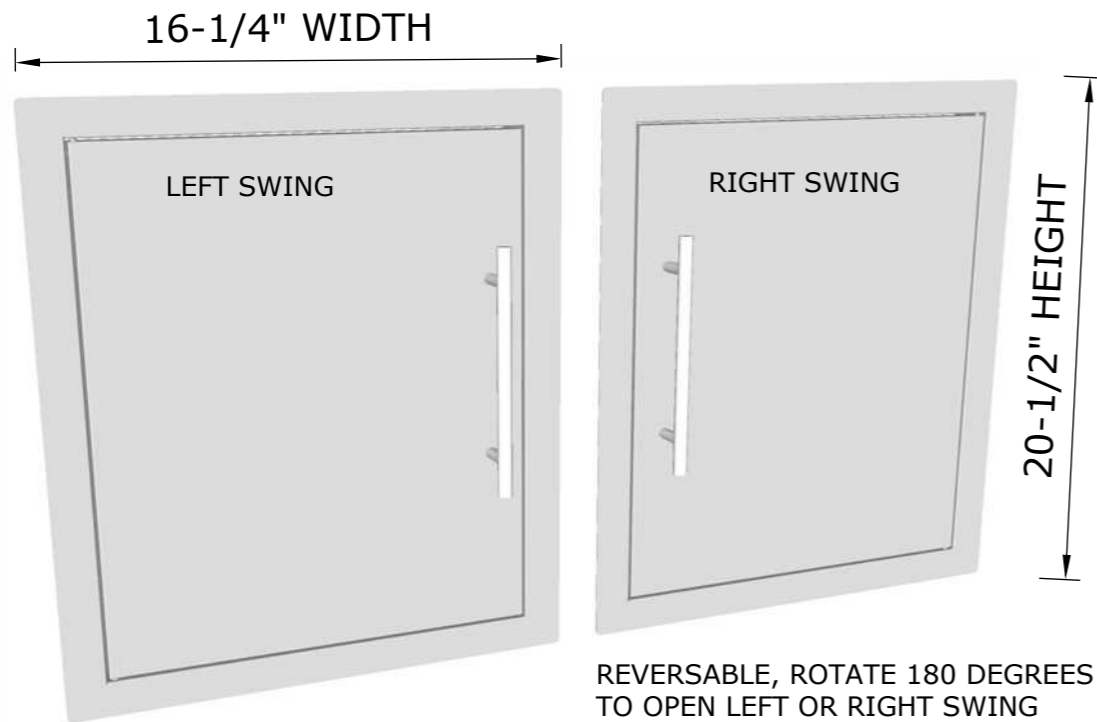

Product Features

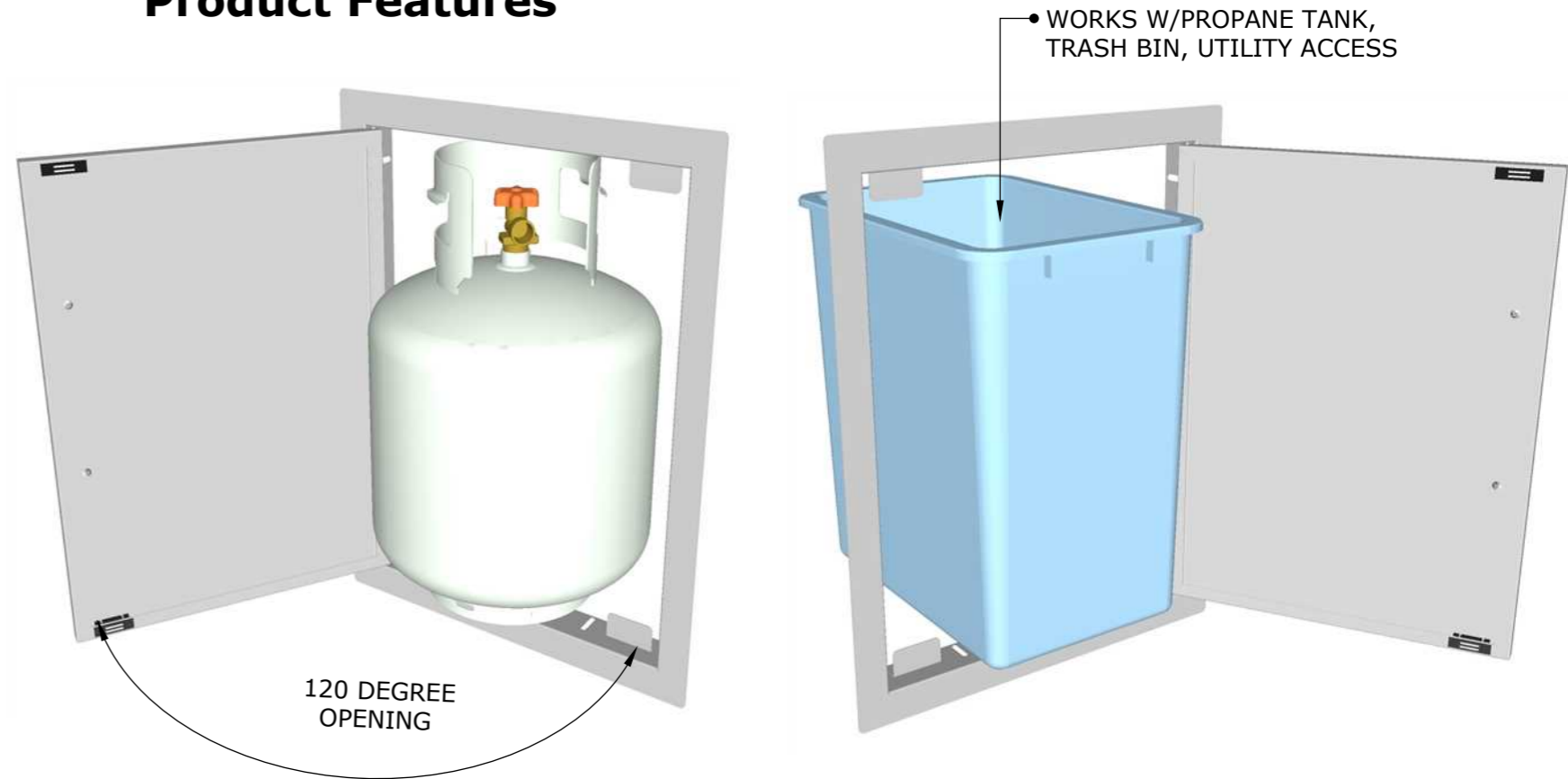

ISLAND WALL CUT-OUT SIZE:
14-1/2" WIDTH x 19" HEIGHT

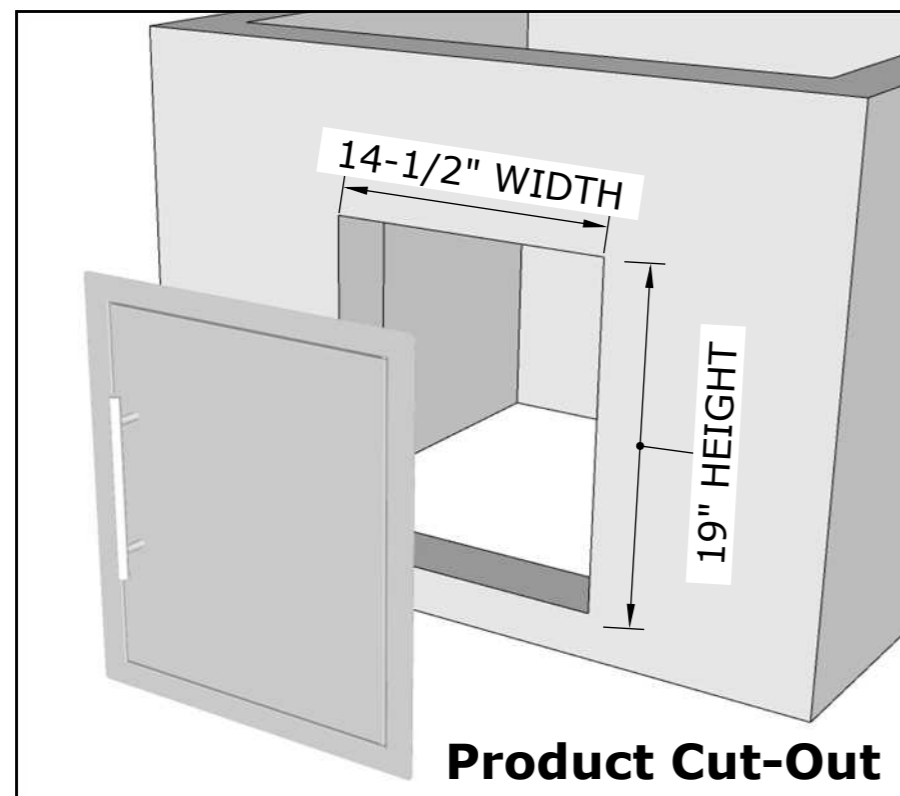

OPEN SLOTS ALLOW FOR EASY INSTALLATION

HAVE COMPONENT ON SITE BEFORE MAKING ISLAND CUTS, CONFIRM ALL DIMENSIONS BEFORE CUTTING INTO ISLAND WALL

MOUNT TO INTERIOR ISLAND CUT-OUT EDGE USING SCREW CONSISTENT WITH YOUR INSTALLATION TYPE. CONCRETE, MASONRY, WOOD, METAL ALL USE DIFFERENT SCREW TYPES (HARDWARE NOT INCLUDED)

