

# TEXAN SERIES ODK COMPONENTS

## PRODUCT

16" Paper Towel Holder  
Drawer Combo

Item No. TEX-16PCD

## DESCRIPTION

16" Texan Series Swivel Paper  
Towel Holder & Single Extra-  
Large Drawer

## PRODUCT DIMENSIONS

**Product Size:** 16-1/4" WIDTH x  
20-1/2" HEIGHT x 21" DEPTH  
**Cut-Out Size:** 14-1/2" WIDTH x  
19" HEIGHT x 21-1/2" DEPTH

## SPECIFICATIONS

304 Stainless Steel  
Construction Frame, Drawers,  
Galvanized Cabinet Box (Not  
Exposed to Elements) 304 SS  
Rod Handle

## WARRANTY

- EXTERIOR FINISH -----3 YEARS
- STRUCTURE -----3 YEARS
- HANDLE-----1 YEAR

### Product Dimensions

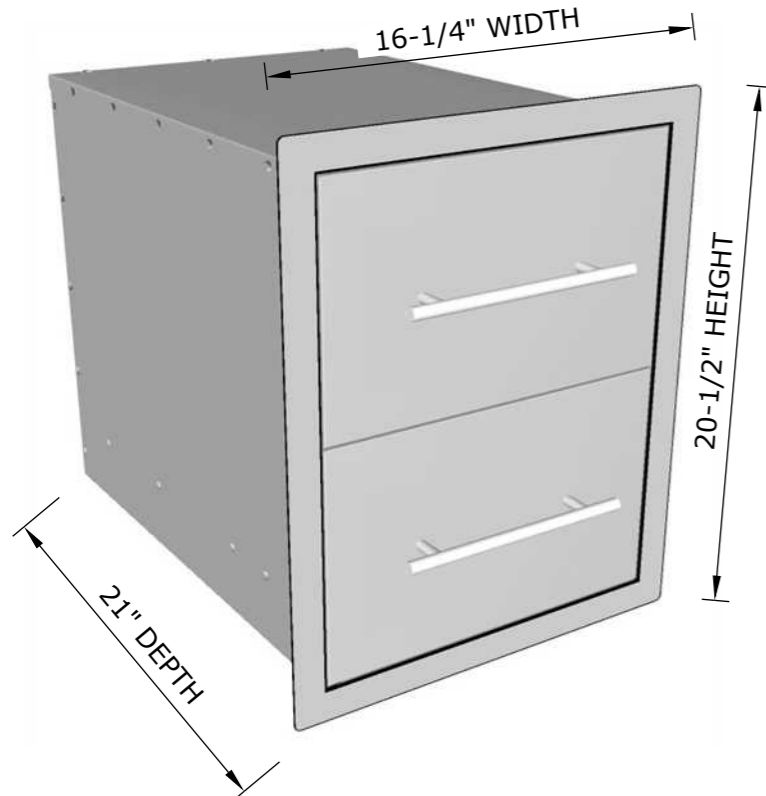

### Mounting Holes

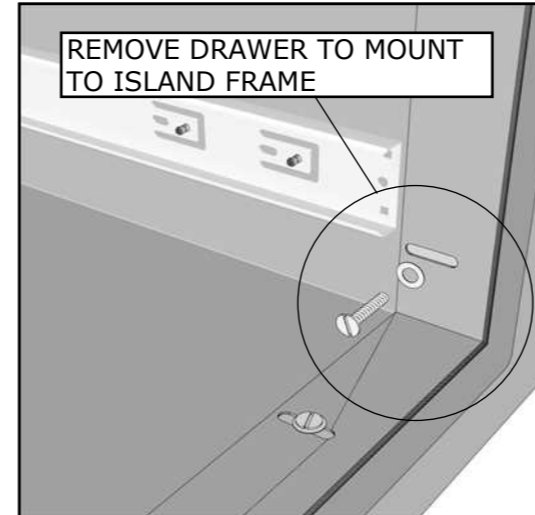

HAVE COMPONENT ON SITE BEFORE MAKING ISLAND CUTS, CONFIRM ALL DIMENSIONS BEFORE CUTTING INTO ISLAND WALL

MOUNT TO INTERIOR ISLAND CUT-OUT EDGE USING SCREW CONSISTENT WITH YOUR INSTALLATION TYPE. CONCRETE, MASONRY, WOOD, METAL ALL USE DIFFERENT SCREW TYPES (HARDWARE NOT INCLUDED)

### Drawer Box Support

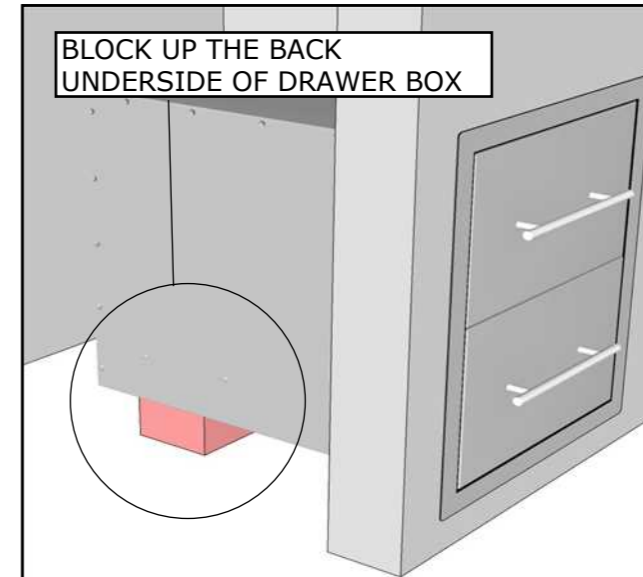

ISLAND WALL CUT-OUT SIZE:  
14-1/2" WIDTH x 19" HEIGHT x 21-1/2" DEPTH

### Product Features

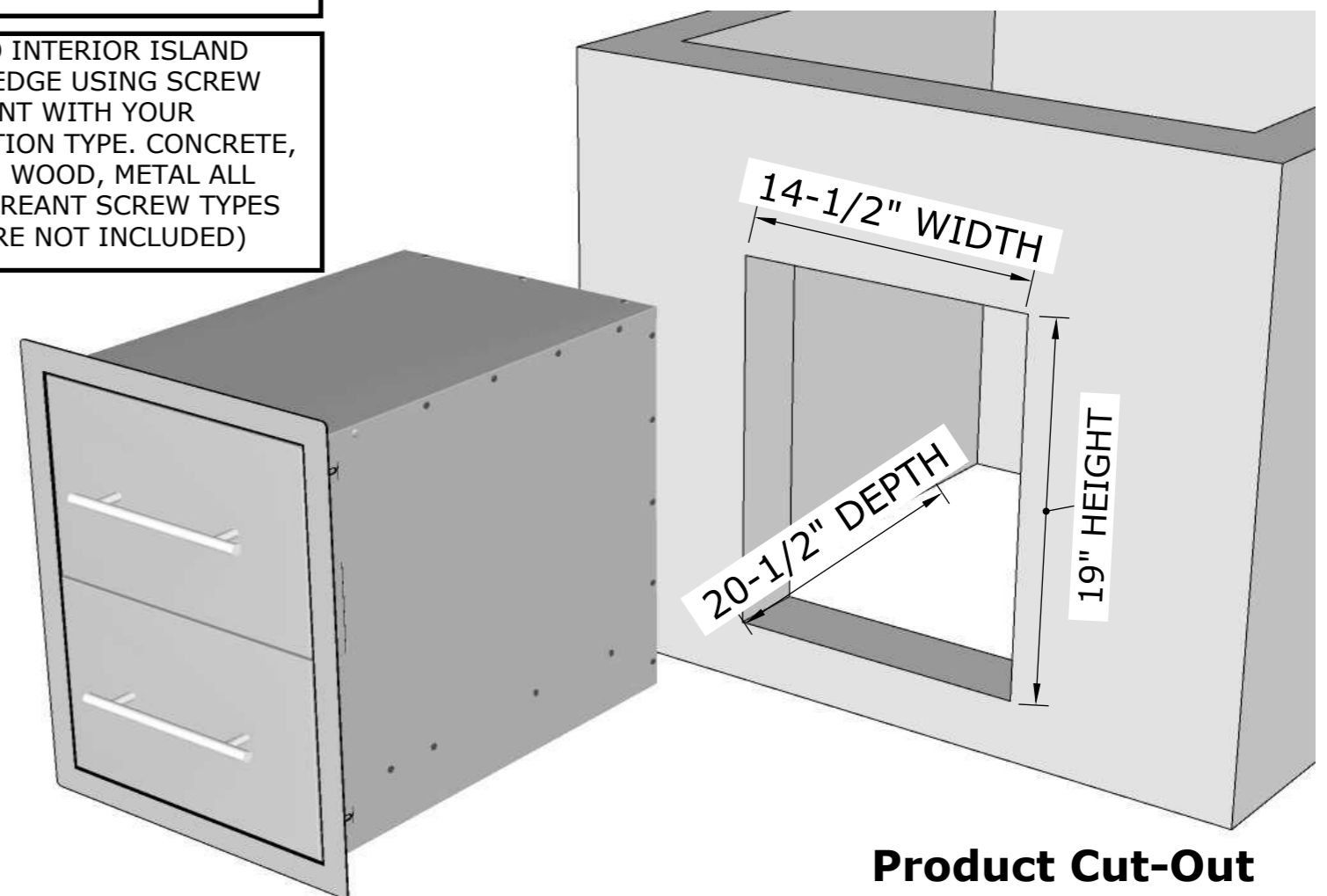
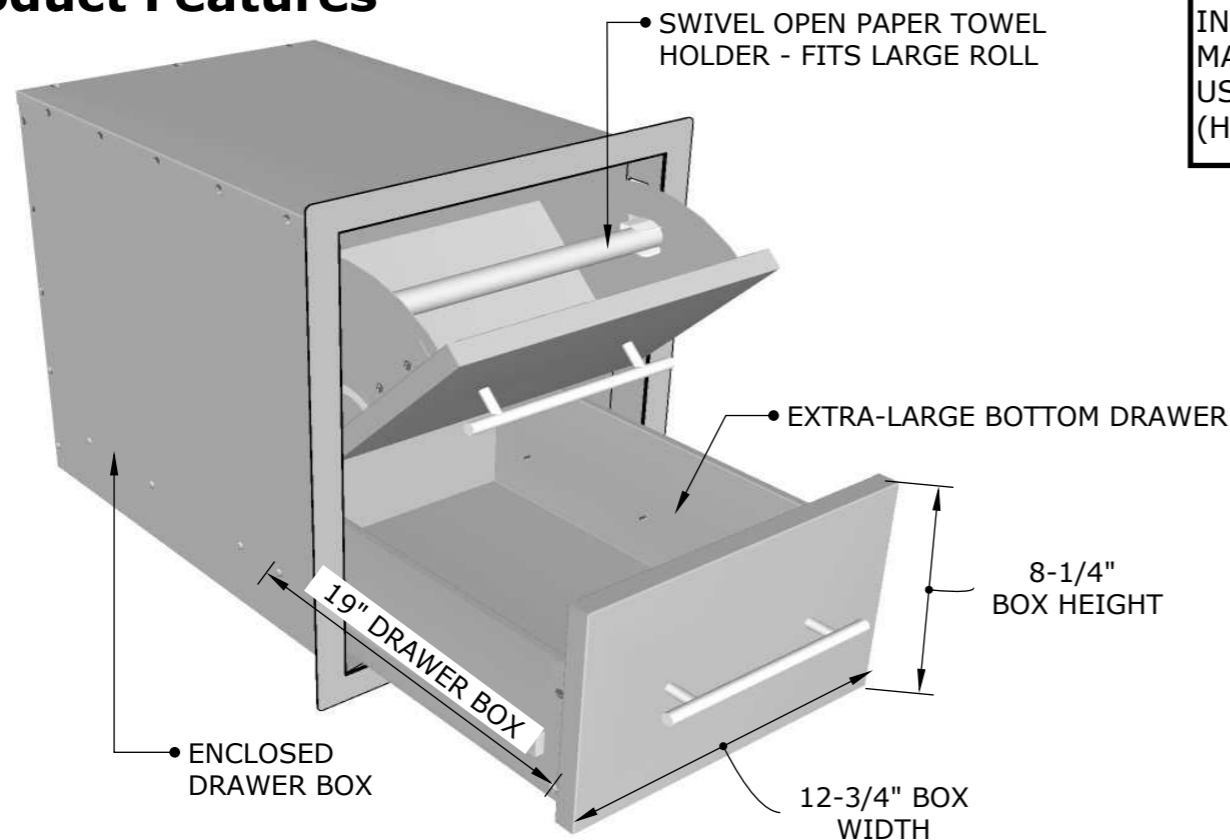

### Product Cut-Out