

ARUBA SERIES ODK COMPONENTS

PRODUCT

30" Triple Drawer Door Combo

Item No. ARU-TDC30

DESCRIPTION

30" Aruba Series Triple Drawer Door Combo w/Removable Support Frame, Cutlery Drawer & Two Large Storage Drawers

PRODUCT DIMENSIONS

Product Size: 30" WIDTH x 20-1/2" HEIGHT x 20" DEPTH
Cut-Out Size: 28-1/8" WIDTH x 19" HEIGHT x 20-1/2" DEPTH

SPECIFICATIONS

304 Stainless Steel Construction Frame, Door & Drawers, Galvanized Cabinet Box (Not Exposed to Elements)

WARRANTY

3 YEARS STRUCTURE WARRANTY AGAINST MANUFACTURE DEFECTS

Product Dimensions

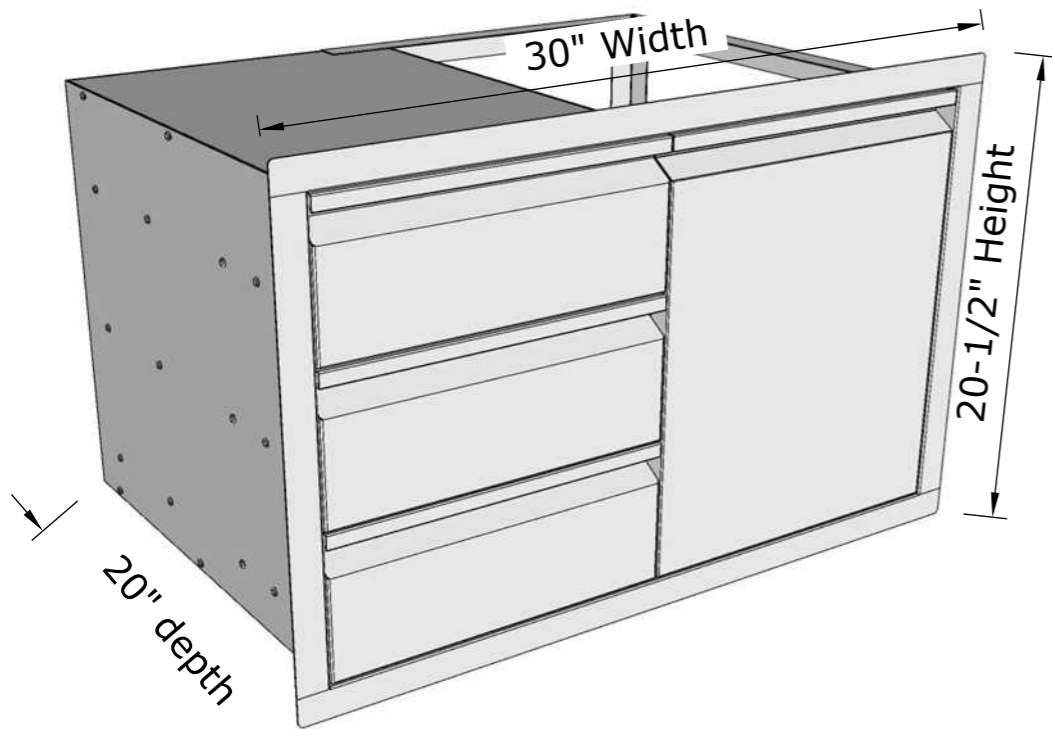

Product Features

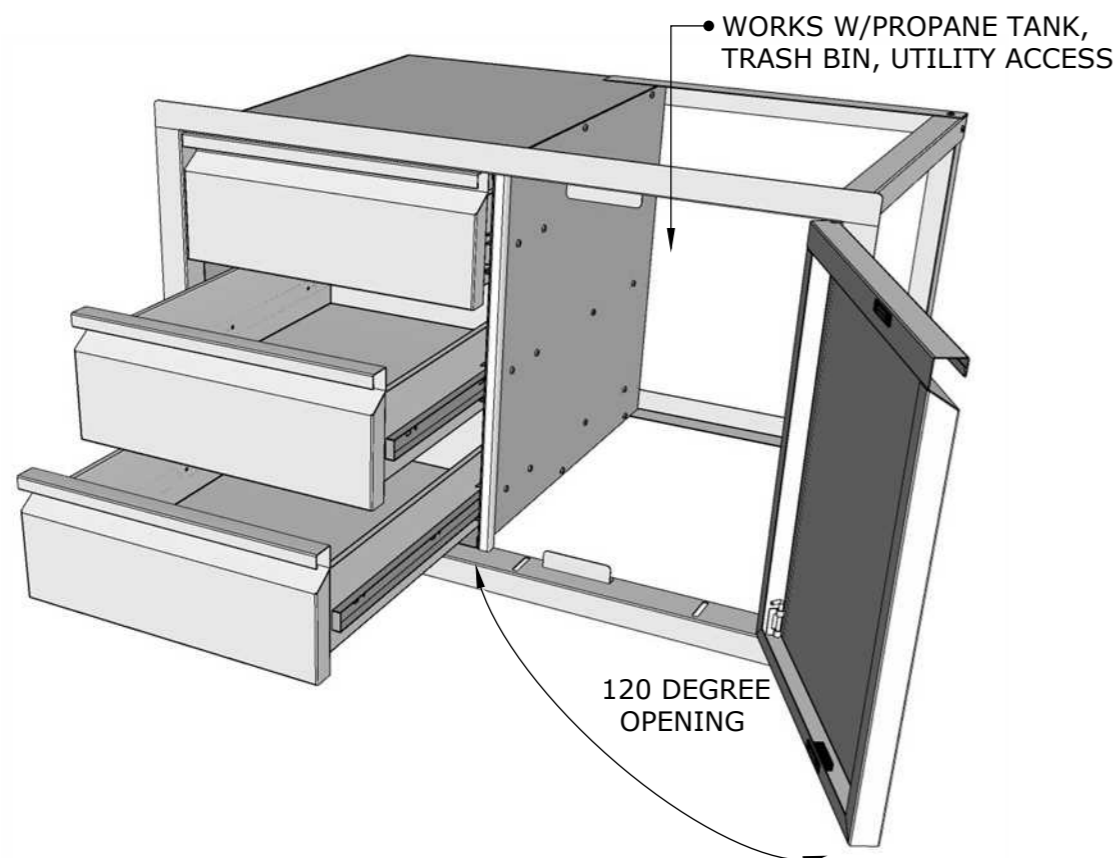

DISASSEMBLE INTERIOR FRAMING FOR CLEAR ISLAND ACCESS

MOUNT TO INTERIOR ISLAND CUT-OUT EDGE USING SCREW CONSISTENT WITH YOUR INSTALLATION TYPE. CONCRETE, MASONRY, WOOD, METAL ALL USE DIFFERENT SCREW TYPES (HARDWARE NOT INCLUDED)

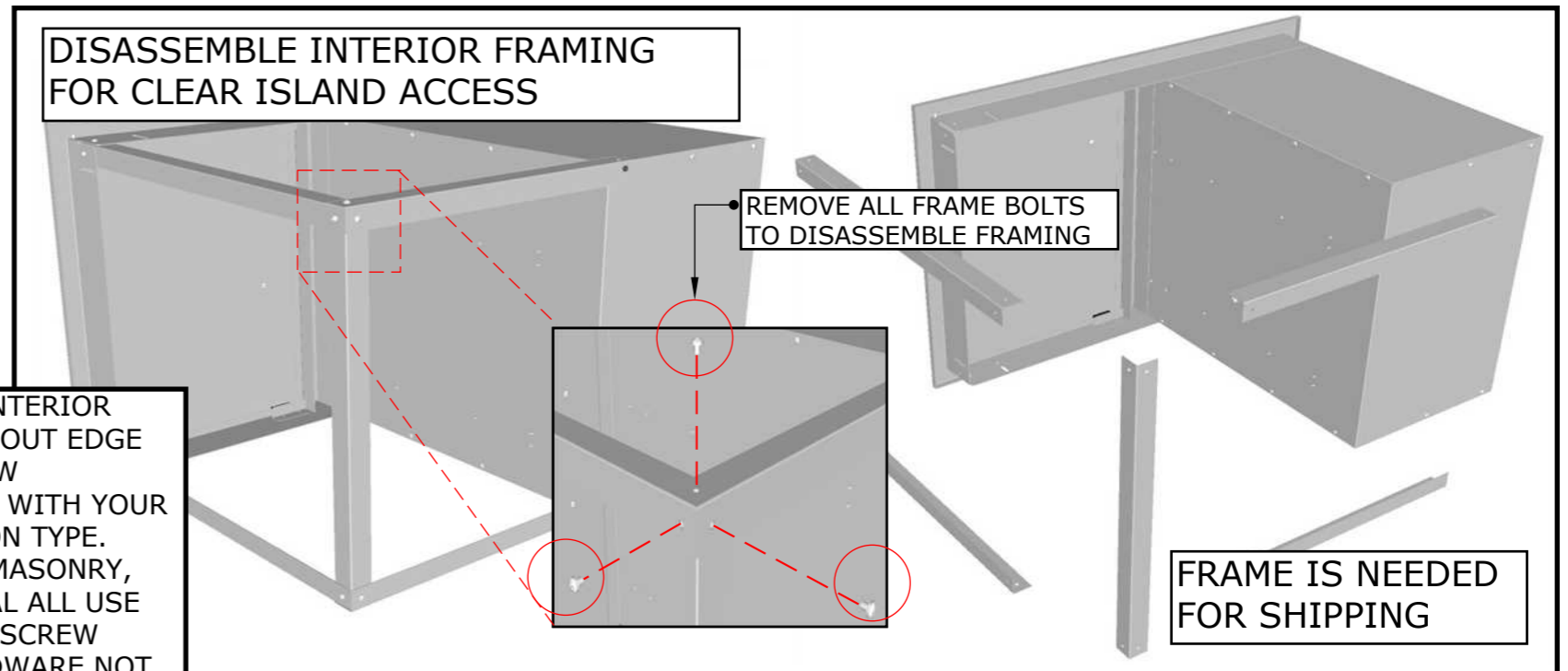

ISLAND WALL CUT-OUT SIZE:
28-1/8" WIDTH x 19" HEIGHT x 20-1/2" DEPTH

Mounting Holes

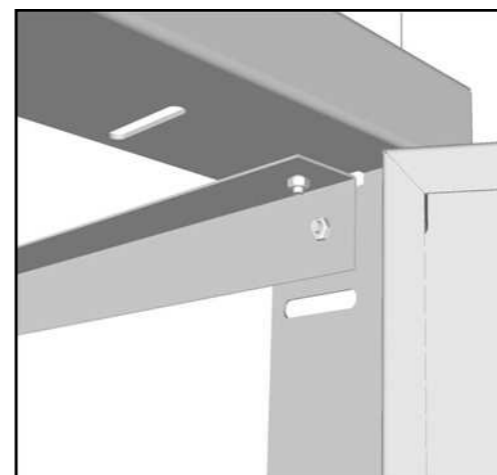

OPEN SLOTS ALLOW FOR EASY INSTALLATION

HAVE COMPONENT ON SITE BEFORE MAKING ISLAND CUTS, CONFIRM ALL DIMENSIONS BEFORE CUTTING INTO ISLAND WALL

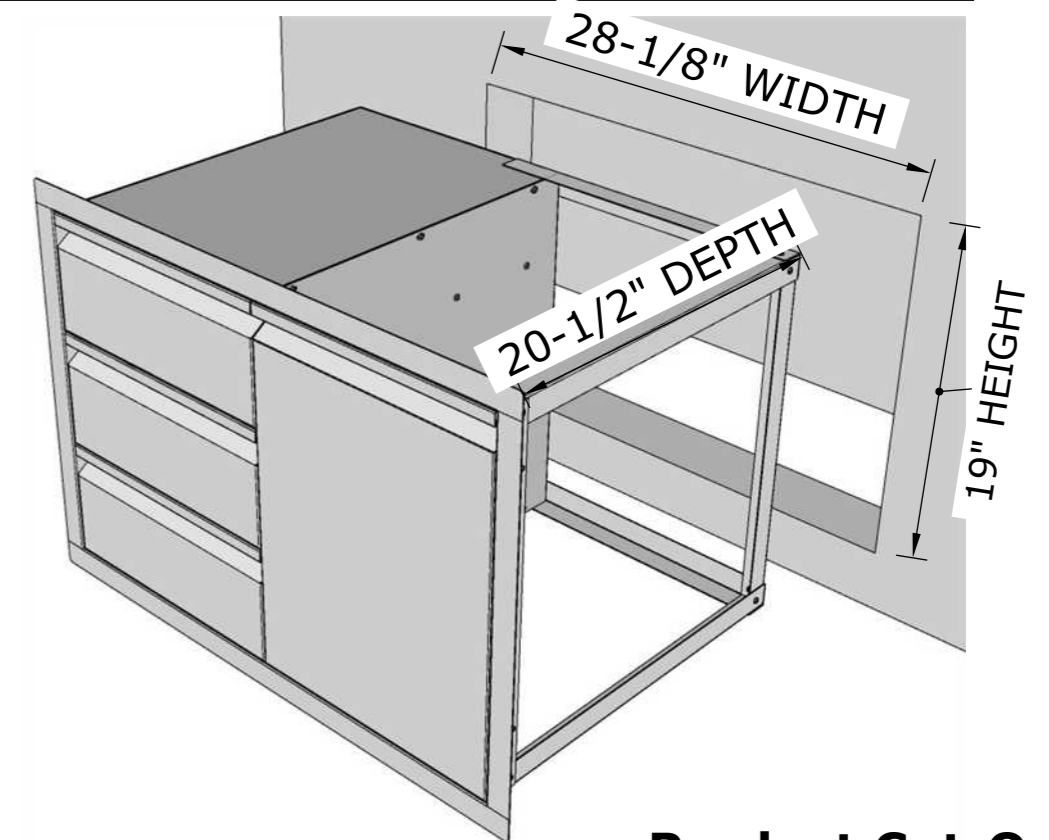

Product Cut-Out