

# Honeywell

# H7725A, H7726A, H7735A, H7736A Wall Humidity/ Temperature Sensors

## INSTALLATION INSTRUCTIONS



## LIMITES DE L'APPLICATION DU PRODUIT

Les produits Honeywell ne sont pas conçus pour des applications de sécurité ou de sauvetage. Les produits Honeywell ne sont pas conçus pour les applications critiques, comme les installations nucléaires, les dispositifs implantables dans le corps humain ou d'assistance vitale. Honeywell n'est pas responsable, en tout ou en partie, des réclamations ou dommages découlant d'une telle utilisation.

## IMPORTANT WARNINGS

- Only qualified trade installers should install this product.
- This product is not intended for life-safety applications.
- Do not install in hazardous or classified locations.
- The installer is responsible for all applicable codes.
- De-energize power supply prior to installation or service.

## AVERTISSEMENTS IMPORTANTES

- Seuls les installateurs spécialisés sont autorisés à installer ce produit.
- Ce produit n'est pas destiné aux applications de sécurité ou de sauvetage.
- Ne l'installez pas dans des endroits dangereux ou classés comme tels.
- L'installateur doit respecter tous les codes applicables.
- Coupez l'alimentation électrique avant l'installation ou l'entretien.

## PRODUCT APPLICATION LIMITATION

Honeywell products are not designed for life or safety applications. Honeywell products are not intended for use in critical applications such as nuclear facilities, human implantable device or life support. Honeywell is not liable, in whole or in part, for any claims or damages arising from such uses.

## INSTALLATION

1. **IMPORTANT!** Per Fig. 1 locate sensor in an area away from ventilation sources and heat generating equipment and appliances. Sensor should be mounted at light switch height in a vertical orientation. Use insulating material behind sensor to ensure reading accuracy.

NOTE: Do not install sensor in multi-gang electrical boxes with line voltage or other electrical devices.

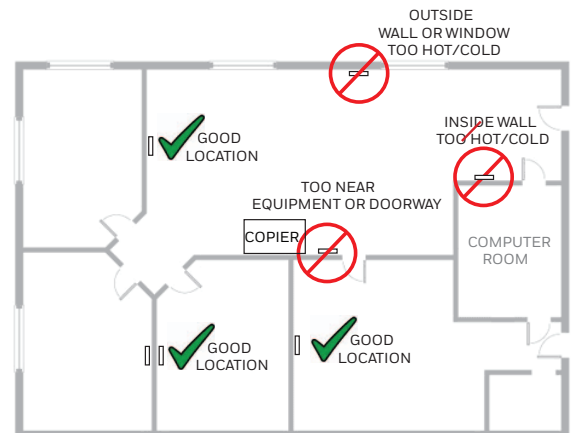

Fig. 1.



31-00447M-01

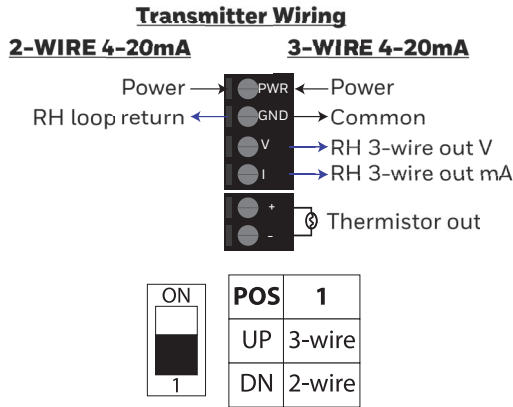

Fig. 2.

2. Wire sensor as shown per Fig. 2.
3. Set the slide selector position (on back of device) to accommodate either 2-wire or 3-wire outputs. This selector must be 'up' for a voltage output.
4. To change between 0-5V and 0-10V, remove front cover of device and adjust DIP 1 switch position (on front of device). Replace cover.

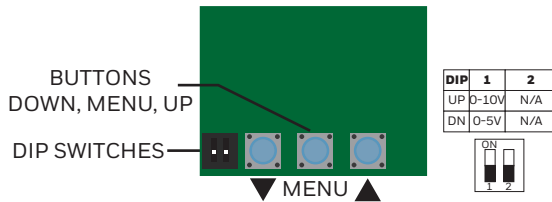

Fig. 3.

5. To install in a junction box, mount device to box using two screws. To install without junction box, rotate top and bottom drywall clamps completely counter-clockwise. Place into drywall cutout, then turn clamp screws clockwise until they are secured tightly against the drywall. Sensor must be installed in the orientation shown.
6. Apply power to sensor.

## OPERATION

Press center MENU button to access (1 press) %RH offset mode. A red LED will blink to indicate %RH offset setting.

The down ▼ arrow and up ▲ arrow can be used to decrease or increase offset values in 0.1 increments up to ±5%.

## DIMENSIONS

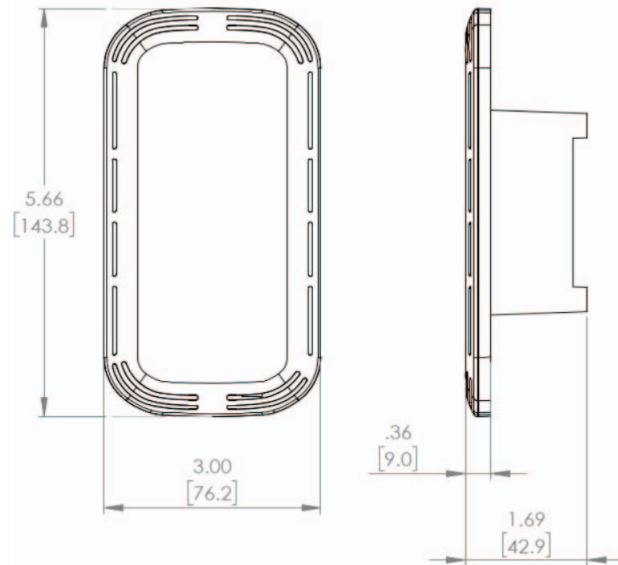

Fig. 4. Dimensions in inches [mm].

## TROUBLESHOOTING

Table 1. Troubleshooting.

Symptom	Solution
No output	Check wiring. Ensure power supply meets requirements.
Temp or RH reading error	Verify control panel software is configured for correct output scaling.
	Verify accuracy of test instrument. Observe installation and calibration guidelines.
	Verify unit is securely installed on duct without excessive air leakage.
	Offset calibration only if necessary.
Sensor damage, contamination, or long-term drift	Replace sensor element. Consult factory for ordering information.

## CALIBRATION

Honeywell RH sensors are factory calibrated to NIST traceable standards. No field calibration is necessary or recommended. However, to facilitate compliance with commissioning requirements field calibration offsets are allowed.

1. Locate calibration instrument and sensor in close proximity to each other in a controlled environment free of drafts, people, and equipment to reduce influence on RH and temperature.
2. Allow both readings to stabilize (10-30 minutes). Compare reading of sensor to calibration instrument, and calculate difference.

3. Refer to OPERATION section to change offsets as needed. Setting an offset of zero restores factory calibration.

## SPECIFICATION BY MODEL (TABLE 2).

Table 2. Models.

Product Number	Humidity Accuracy	Temperature Sensor
H7726A2020	2%	1097 Ohm
H7725A2010	2%	20 kOhm
H7736A2022	3%	1097 Ohm
H7735A2012	3%	20 kOhm
H7725A2010-C	2% NIST Certified	20 kOhm

## WASTE ELECTRICAL AND ELECTRONIC EQUIPMENT (WEEE)



Correct disposal of this product (applicable in the European Union and other European countries with separate collection systems). This product should be disposed of, at the end of its useful life, as per applicable local laws, regulations, and procedures.

## PROP-65 WARNING



This product can expose you to chemicals including 1, 3-Butadiene, which is known to the state of California to cause cancer and reproductive harm. For more information, go to [www.P65Warnings.ca.gov](http://www.P65Warnings.ca.gov).

## SPECIFICATIONS

Table 3. Specifications.

Power supply	AC Supply/ DC Supply	24VAC, 100mA max. 12-30VDC, 50mA max.
Outputs	RH	3-wire 0-5V/10V <sup>4</sup> , 3-wire or 2-wire 4-20mA (Selectable)
Output scaling	RH	0-100%RH
Thermistor/ RTD	Nominal resistance @ 25 °C	20 kOhm 1097 kOhm
Relative Humidity	Accuracy	2% models: ±2% max 0 to 100% RH, ±1.5% typ 0 to 80% RH @25°C
		3% models: ±3% max 0 to 100% RH, ±2% typ 0 to 100% RH @25°C
	Resolution	0.01% RH
	Hysteresis	±0.8% RH
	Repeatability	0.08% RH
	Non-linearity	Factory linearized <1%RH
	Temperature coefficient	Fully compensated by on-board sensor
	Response time <sup>2</sup>	8s
	Output update	0.5s
	Operating range	0 to 100% RH (non-condensing)
	Long term drift	<0.25% RH per year
	Operating conditions <sup>3</sup>	41 to 140°F (5 to 60°C) @ 20-80% RH
Enclosure	Materials	ABS/Polycarbonate
	Dimensions	5.66”h x 3.00”w x 0.36”d (1.69” depth including recessed components)
	Enclosure Rating	IP20/NEMA 1
	Unit Temp Rating	-40°F to 158°F (-40 to 70°C)

<sup>1</sup> One side of transformer secondary is connected to signal common. Dedicated transformer is recommended.

<sup>2</sup> Time for reaching 63% of reading at 25°C and 1 m/s air-flow.

<sup>3</sup> Long term exposures to conditions outside normal range or high humidity may temporarily offset the RH reading (+3%RH after 60 hours).

<sup>4</sup> 15-30VDC/24VAC power supply voltage required for 10 volt output.

**Honeywell Building Technologies**

In the U.S.:

Honeywell

715 Peachtree Street NE

Atlanta, GA 30308

[customer.honeywell.com](http://customer.honeywell.com)

[buildingcontrols.honeywell.com](http://buildingcontrols.honeywell.com)



® U.S. Registered Trademark  
©2020 Honeywell International Inc.  
31-00447M-01 M.S. 11-20  
Printed in United States

**Honeywell**