

## M7161, M7164, M7184 Modutrol IV Motors

*The M7161, M7164 and M7184 Electronic Modutrol Motors provide proportioning control of zone dampers and valves when used with modulating dc voltage input.*

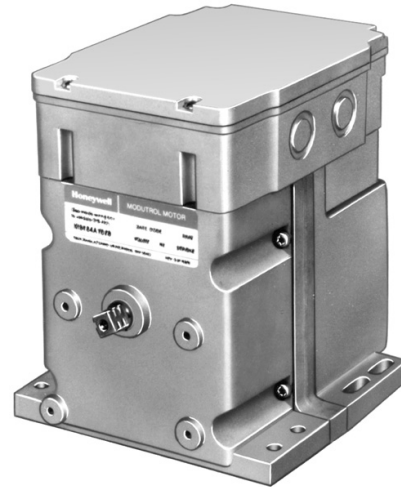

- M7161 and M7164 replace M734H,J Motors and Ranco LA2-1000 and 2000 Linear Actuators.
- M7184 replaces M744D Motors.
- M7161, M7164 rated for 35 lb-in. torque.
- M7184 rated for 150 lb-in. torque.
- M7164G is electrically normally open; all other motors are electrically normally closed.
- Oil immersed motor and gear train for reliable performance and long life.
- Wiring box provides NEMA 3 weather protection.
- Actuator motor and circuitry operate from 24 Vac. Models available with factory installed transformer, or an internal transformer can be field added.
- Quick-connect terminals standard—screw terminal adapter available.
- Adapter bracket for matching shaft height of older motors is standard with replacement motors.
- Nominal timing of 30 seconds for 90° stroke and 60 seconds for 160° stroke.
- Valve and damper linkages, explosion proof housing, and auxiliary switches available as accessories.
- Die-cast magnesium housing.
- Used with Honeywell W7080 Multizone System.

### CONTENTS

<i>Specifications</i> .....	2
<i>Ordering Information</i> .....	2
<i>Installation</i> .....	4
<i>Operation and Replacement</i> .....	9
<i>Checkout</i> .....	11

# Specifications

**MODELS:**

**M71 6 1 A,B,G**  
**M71 6 4 A,B,G**  
**M71 8 4 A**

**Control Type**  
**71** is dc voltage input  
 0.8-3.3, 4-7, 6-9 or  
 10.5-13.5 Vdc

**Power Rating**  
**6** is low power—  
 35 lb-in. torque  
**8** is high power—  
 150 lb-in. torque

**Output Drive**  
**4** is dual-ended shaft, nonspring return.  
**1** is single-ended shaft, nonspring return.

**Suffix Letter**  
**A:** is fixed stroke  
 (90° or 160°), electrically  
 normally closed,  
 no auxiliary switches.  
**B:** is fixed stroke  
 (90° or 160°), electrically  
 normally closed,  
 1 auxiliary switch.  
**G:** is fixed stroke  
 (90° or 160°), electrically  
 normally open,  
 no auxiliary switches.

**MOTOR ROTATION:**

Normally closed M7161A,B and M7164A,B; M7184A  
 drives to fully counterclockwise  (as viewed  
 from the power end) to the fully closed position when  
 powered input signal is at a minimum.

Electrically normally open M7161G and M7164G drive  
 clockwise  (as viewed from the power end) to  
 the fully open position when the powered input signal  
 is at a minimum.

**STROKE:** Fixed 90° or 160° stroke models available.

**TIMING:** Nominal 30 seconds for 90° stroke and 60 seconds  
 for 160° stroke.

**DEAD WEIGHT LOAD ON SHAFT:**

	<b>Power End</b>	<b>Auxiliary End</b>
M7161	100 lb (45.4 kg)	N/A
M7164	100 lb (45.4 kg)	100 lb (45.4 kg)
M7184	200 lb (90.8 kg)	200 lb (90.8 kg)

300 lb (136.2 kg) maximum combined (power and auxil-  
 iary end) dead weight load.

**MAXIMUM DAMPER RATING:**

M7161A,B,G and M7164A,B,G: B dimension = 48 in.  
 M7184A: B dimension = 202 in.

**AMBIENT TEMPERATURE RATINGS:**

Maximum: 150° F [66° C] at 25% duty cycle.  
 Minimum: -40° F [-40° C].

**SHAFT:** 3/8 in. [9.5 mm] square.

M7161 Models: Single-ended shaft.  
 M7164 and M7184 Models: Dual-ended shaft.

**DIMENSIONS:** See Fig. 1.

**UNDERWRITERS LABORATORIES INC. LISTED:**

File No. E4436, Guide No. XAPX.

**CANADIAN STANDARDS ASSOCIATION CERTIFIED:**

General Listing File No. LR1620, Guide 400-E.

**ELECTRICAL RATINGS:**

	<b>Voltage Vac @ 50/60 Hz</b>	<b>Current Draw (A)</b>	<b>Power Con- sumption (W)</b>
M7161	24	0.62	14
M7164	120	0.20	19
M7184	24	0.80	18

**AUXILIARY SWITCH RATINGS (Amperes):**

<b>One Contact Rating<sup>a</sup></b>	<b>120V</b>	<b>240V</b>
Full Load	7.2	3.6
Locked Rotor	43.2	21.6

<sup>a</sup> 40 VA pilot duty, 120/240 Vac on opposite contact.

**ACCESSORIES:**

ES650117 Explosion-proof Housing: Encloses motor for  
 use in explosive atmospheres. Not for use with Q601,  
 Q618, and Q455 Linkages. Order separately from Nelson  
 Electric Co. Requires Honeywell 7616DM Coupling.

Q607 External Auxiliary Switch: Controls auxiliary equip-  
 ment as a function of motor position.

# Ordering Information

When purchasing replacement and modernization products from your wholesaler or your distributor, refer to the price sheets for complete ordering number.

If you have additional questions, need further information, or would like to comment on our products or services, please write or phone:

1. Your local Honeywell Home and Building Control Sales Office (check white pages of your phone directory).
2. Home and Building Control Customer Satisfaction  
 Honeywell Inc.,  
 1885 Douglas Drive North  
 Minneapolis, Minnesota 55422-4386 (612) 951-1000

In Canada—Honeywell Limited/Honeywell Limitée, 740 Ellesmere Road, Scarborough, Ontario M1P 2V9. International Sales and Service Offices in all principal cities of the world. Manufacturing in Australia, Canada, Finland, France, Germany, Japan, Mexico, Netherlands, Spain, Taiwan, United Kingdom, U.S.A.

- Q605 Damper Linkage: Connects motor to damper. *Includes motor crank arm.*
- Q618 Linkage: Connects Modutrol Motor to water or steam valve.
- Q601 Bracket and Linkage Assembly: Connects Modutrol Motor to water or steam valve.
- Q5001 Valve Linkage: Connects Modutrol Motor to water or steam valve.
- Q100 Linkage: Connects Modutrol Motor to butterfly valve.
- 221455A Motor Crank Arm: Infinitely adjustable crank arm. Approximately 0.75 inch shorter than the 4074ELY Crank Arm; can rotate through downward position and clear base of motor without requiring use of adapter bracket.
- 7617ADW Motor Crank Arm: Approximately 0.75 inch shorter than the 7616BR Crank Arm; can rotate

- through the downward position and clear base of motor without requiring use of adapter bracket.
- 220738A Adaptor Bracket: Raises shaft height 0.75 in. [19 mm].
- 220741A Screw Terminal Adapter: Converts the standard quick-connect terminals to screws terminals.
- Transformers: Mounted internally, provide 24 Vac power to motor.
  - 198162JA: 24 Vac, 50/60 Hz (for electrical isolation).
  - 198162EA: 120 Vac, 50/60 Hz.
  - 198162GA: 220 Vac, 50/60 Hz.
  - 198162AA: 120/208/240 Vac, 50/60 Hz.
- 4074ERU Weatherproofing Kit: Provides NEMA 3 rating when Modutrol IV Motor is mounted in other than upright position.

**Fig. 1—Dimensions in in. [mm].**

NOTE: M7161 does not have auxiliary shaft. All other dimensions are the same.

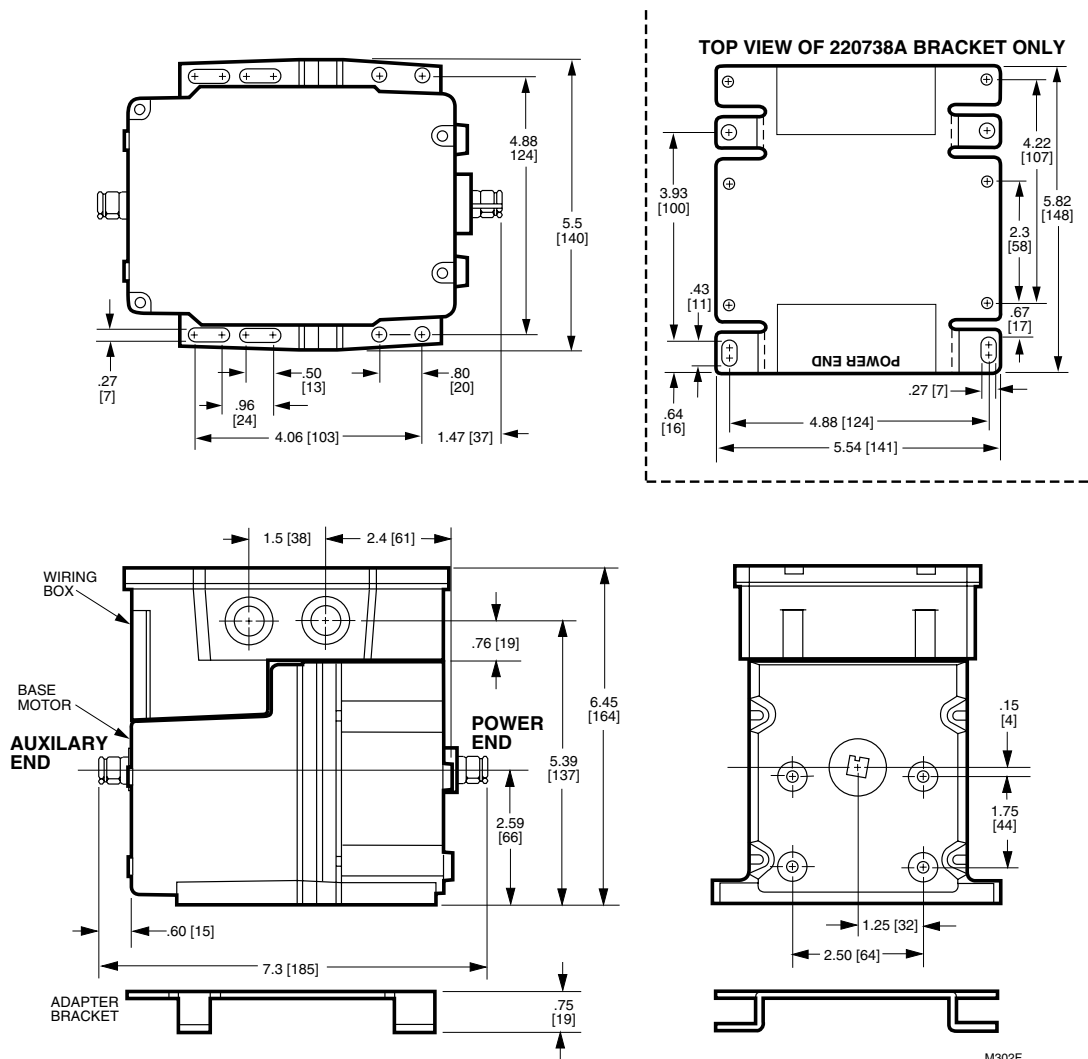

M302F

# Installation

## WHEN INSTALLING THIS PRODUCT...

1. Read these instructions carefully. Failure to follow them could damage the product or cause a hazardous condition.
2. Check the ratings given in the instructions and on the product to make sure the product is suitable for your application.
3. Installer must be a trained, experienced service technician.
4. After installation is complete, check out product operation as provided in these instructions.



## CAUTION

1. Disconnect power supply before beginning installation to prevent electrical shock and equipment damage.
2. Never turn the motor shaft by hand or with a wrench—this will damage the motor.
3. Always conduct a thorough checkout when installation is complete.

## LOCATION

Install the Modutrol Motor in any location except where acid fumes or other deteriorating vapors might attack the metal parts, or in atmospheres of escaping gas or explosive vapors. Motors are rated for ambient temperatures between  $-40^{\circ}\text{F}$  [ $-40^{\circ}\text{C}$ ] and  $150^{\circ}\text{F}$  [ $66^{\circ}\text{C}$ ].

Allow enough clearance for installing accessories and servicing the motor when selecting a location (see Fig. 1). When mounting the motor outdoors in an upright position, use liquid-tight conduit connectors and wiring box to provide NEMA 3 weather protection. When mounting the motor outdoors in other than an upright position, use the 4074ERU Weatherproofing Kit and liquid tight conduit connectors to provide NEMA 3 weather protection.

## MOUNTING

Always install motors with the crankshaft horizontal.

Mounting flanges extending from the bottom of the motor housing are drilled for 1/4 inch [6.4mm] machine screws or bolts.

M7161A,B; M7164A,B and M7184A Motors are shipped from the factory in the closed position (at the limit of counterclockwise rotation as viewed from the power end of the motor). M7161G and M7164G are shipped in the open position (at the limit of clockwise rotation as viewed from the power end of the motor). See Fig. 2.

## ADAPTER BRACKET

The 220738A Adapter Bracket, positioned between the motor and the equipment, raises the shaft height of the motor by 0.75 inch to match that of the M734 and M744 Motors. This is required on all valve linkage applications, Q607 External Auxiliary Switch applications, and on some

damper linkage applications (either to provide clearance for the crank arm to rotate through the downward position, or to allow the damper linkage to reach the shaft).

To mount the motor with the bracket:

1. Mount the bracket to the equipment with existing or standard bolts.
2. Mount the motor to the bracket, with the bolts provided, through the threaded holes in the bracket. See Fig. 3. For valve linkage applications, see Fig. 4, the bracket should first be mounted to the linkage so the bracket can provide a convenient base for positioning the motor. After the motor shaft is aligned, it can then be attached to the bracket with the four bolts provided. The bolts are inserted through the inner set of slots on the motor flange and into the threaded holes of the bracket.

## DAMPER LINKAGES

A 220738A Mounting Bracket is packed with replacement motors. Using this bracket is optional for many damper applications. The bracket may be needed in damper

Fig. 2—Limits of motor rotation.

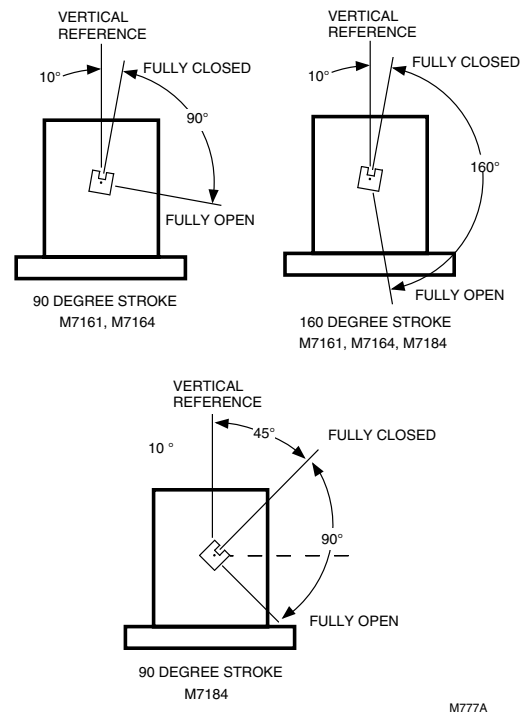

applications requiring the crank arm to rotate through the bottom plane of the actuator. If the bracket is not used in a replacement application, the damper linkage must be adjusted to the new shaft position.

The motor comes without a crank arm. The crank arm is included in the Q605 Linkage or may be ordered separately (see Accessories).

For detailed instructions on the assembly of specific linkages, refer to the instructions packed with each linkage. In general, however, check the following points of operation when installing a motor and linkage:

1. Linkages for valves and louver type dampers should be adjusted so that the damper or valve moves through only

the maximum required distance while the motor moves through its full stroke.

2. With modulating control, maximum damper opening should be no more than 60°. Little additional airflow is provided beyond this point.

3. The motor must be stopped at the end of its stroke by the limit switch and must not be stalled by the damper or valve. The motor will be damaged if it is not permitted to complete its full stroke.

4. Do not exceed the motor ratings in any installation.

5. Do not turn motor shaft manually or with a wrench—this will damage the motor.

**Fig. 3—Mounting motor with an adapter bracket. The bracket is first mounted to the equipment with standard bolts. The motor is then mounted to the bracket using the bolts provided that thread into the bracket holes.**

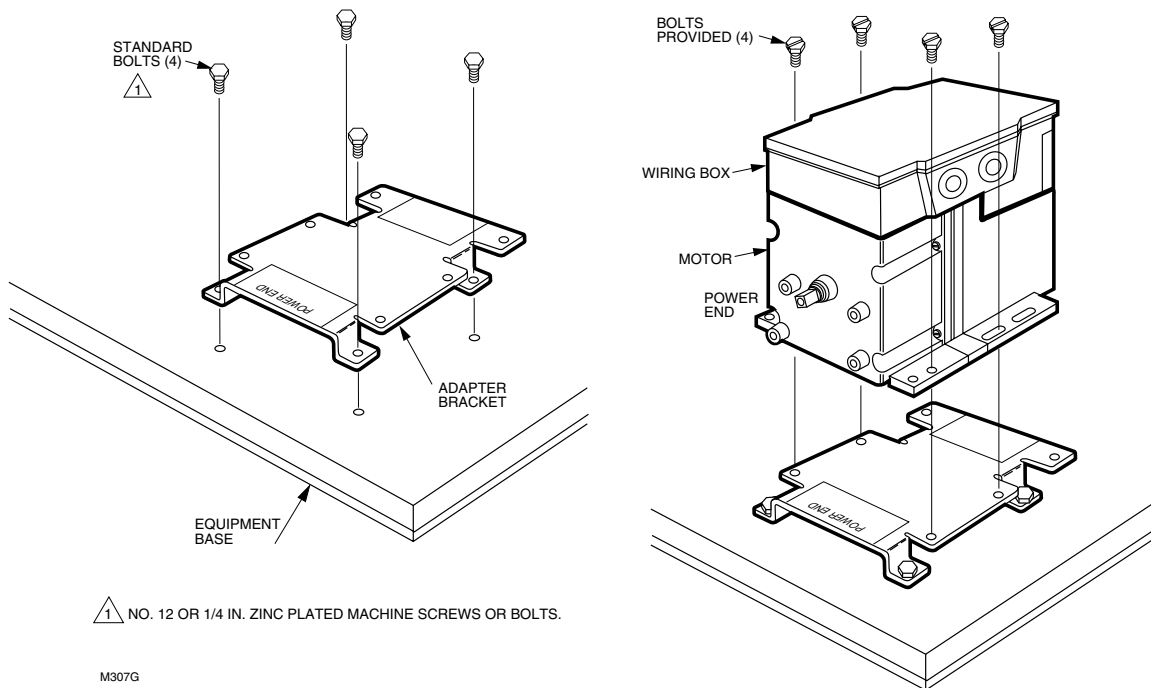

**Fig. 4—Motor mounting on Q618 Valve Linkage.**

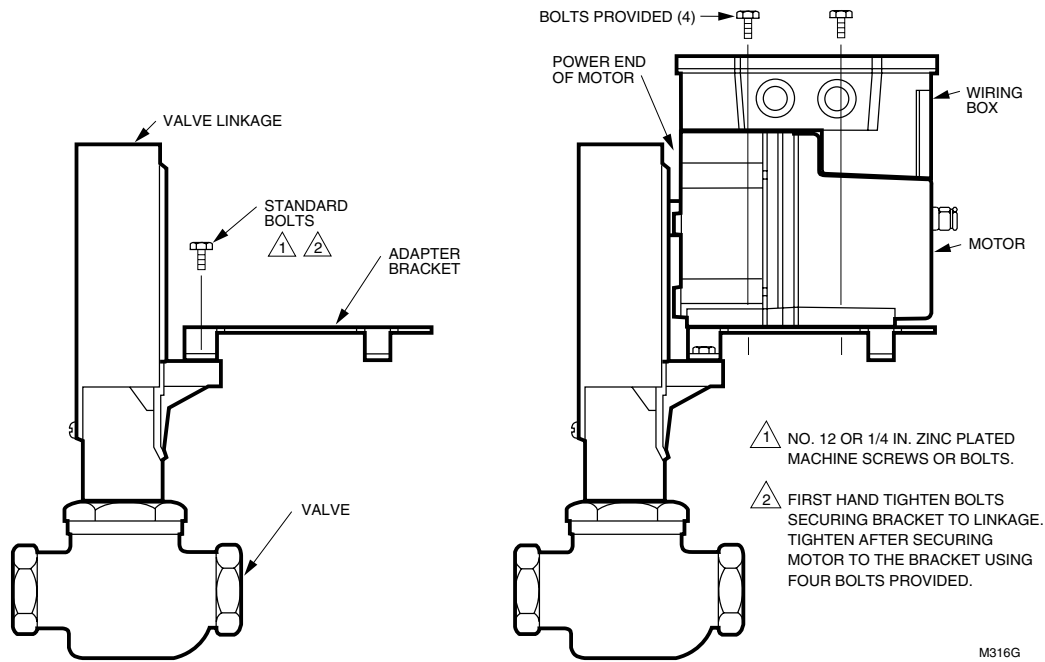

**VALVE LINKAGES**

The 220738A Mounting Bracket must be used with the Q100, Q601 and Q618 Linkages in all valve applications. Refer to instructions packed with each linkage for detailed assembly instructions. The 220738A Mounting Bracket is not required for the Q5001 Linkage.

**WIRING**

Disconnect power supply before wiring to prevent electrical shock or equipment damage. All wiring must agree with applicable codes, ordinances, and regulations.

Make sure that the voltage and frequency stamped on the motor correspond to the characteristics of the power supply. See Figs. 6-7 for typical system wiring.

Make certain that the voltage and frequency stamped on the transformer correspond to the characteristics of the power supply.

The motor terminals are quick-connects located on top of the printed circuit board shown in Fig. 5. Access to the wiring compartment is gained by removing the four screws on the top of the wiring box and lifting off the cover.

**AUXILIARY SWITCH**

The auxiliary switch in the M7161B and M7164B is an spdt switch that is actuated by an adjustable cam. The cam is factory-mounted on the motor shaft at the power end of the motor. The setting of the cam determines the point in the motor shaft rotation at which the auxiliary equipment will be switched on or off. Auxiliary switch wiring is shown in Fig. 8.

**Fig. 5—Terminals and auxiliary switch.**

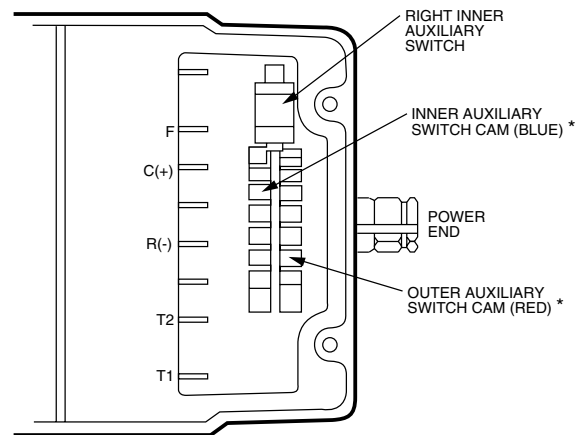

\* M7161B1018 INNER CAM IS RED; OUTER CAM IS BLUE.

NOTE: FEATURES AVAILABLE ON SOME MODELS ONLY.

M439D

**Fig. 6—Parallel-connected motors with one input signal.**

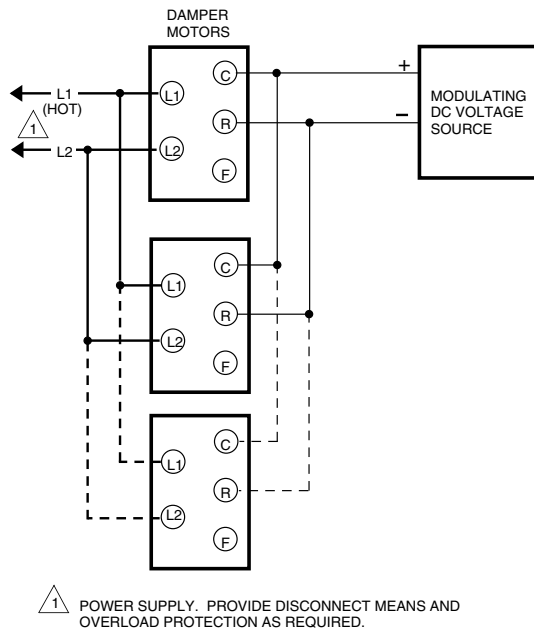

**Fig. 7—Optional override switches to drive motor open or closed.**

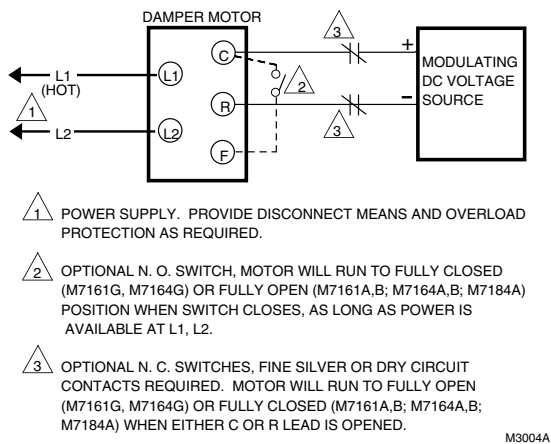

**AUXILIARY SWITCH SETTING PROCEDURE (Fig. 9)**

**CAUTION**

1. Live circuits are exposed during the auxiliary switch adjustment procedure. Always turn off power before adjusting switch cams.
2. Do not turn motor shaft by hand or with wrench as damage to the motor can result.

**Fig. 8—Auxiliary switch color-coded leadwires in M7161B, M7164B.**

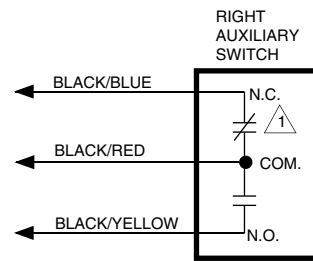

- 1 NORMALLY CLOSED CONTACT MAKES RED TO YELLOW WHEN SWITCH FOLLOWER IS ON UPPER LEVEL.
  - 2 WIRING SHOULD BE NEC CLASS 1 UNLESS POWER SUPPLY MEETS CLASS 2 REQUIREMENTS. TAPE UNUSED LEADS. MAKE CERTAIN THE CURRENT DRAW OF THE EXTERNAL CIRCUIT IS LESS THAN CONTACT RATING OF SWITCH.
  - 3 LEADS ARE BLACK WITH COLORED TRACERS.
- M3003

**NOTE:** The following instructions are for normally closed motors (motor shaft rotates clockwise , as viewed from the power end of the motor, on an increase in signal).

1. Remove cover of wiring box.
2. Run motor to fully closed position.
3. Determine amount of shaft rotation, in degrees, desired before switch is energized.
4. Turn off power. Note position of cam slots:
  - a. If 10° differential is desired, rotate the cam with screwdriver to the desired position for switch action.
  - b. If 1° differential is desired, rotate the cam approximately 180° with screwdriver, then rotate to desired position for switch action.

**NOTE:** Each division on the cam represents 15° of motor rotation. Therefore, if 60° of motor rotation is desired before switch operates, rotate the cam four divisions from the reference point.

5. Connect auxiliary equipment to auxiliary switch leads. See Wiring section.
6. Turn on power and check for proper switch differential and switching of auxiliary equipment by driving the motor through full stroke in both directions. If necessary, repeat steps 4 and 6 until correct switching action is obtained.
7. Replace cover of wiring box.

**CAUTION**

Before servicing, disconnect *all* power supplies to de-energize the auxiliary switches.

**Fig. 9—Auxiliary switch adjustments.**

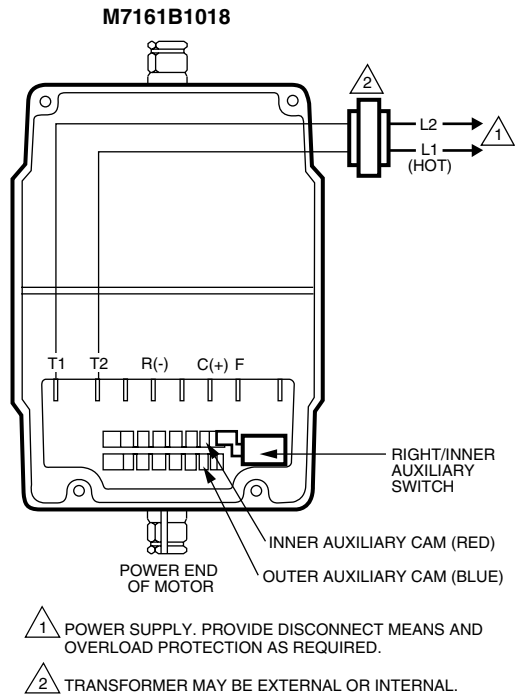

MOVE SCREWDRIVER AT TOP ONLY TO ADJUST CAM.

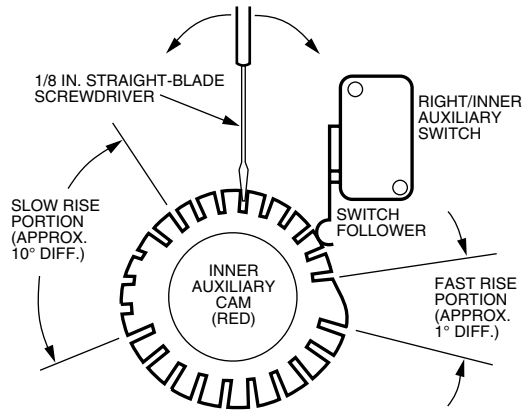

**M7161A,G; M7164; M7184**

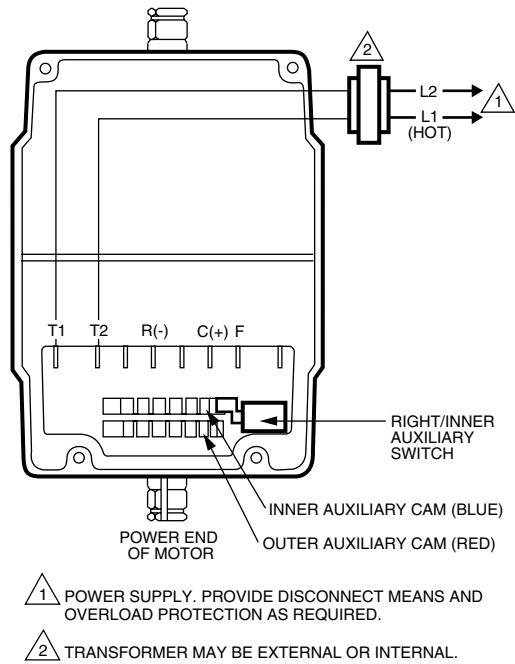

MOVE SCREWDRIVER AT TOP ONLY TO ADJUST CAM.

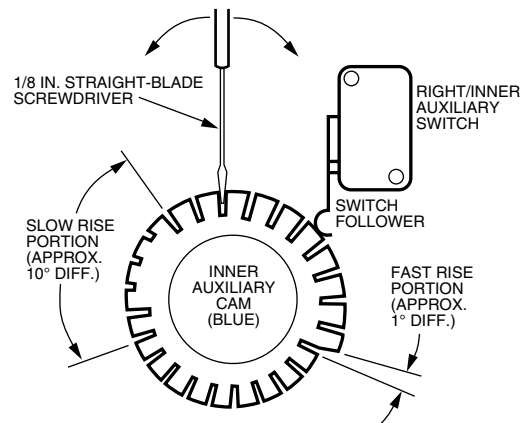

M440D



# Operation and Replacement

## OPERATION

The M7161, M7164 and M7184 Motors operate in response to a dc voltage input signal to terminals C and R, positioning a valve or damper at any position between fully open and fully closed. The input signal causes the modified dc bridge circuit in the motor to become unbalanced. The small signal resulting from the bridge unbalance is amplified and energizes 1 of 2 triacs to run the motor. As the motor runs, a feedback potentiometer driven by the motor moves to rebalance the bridge. When the bridge is balanced, the motor stops.

## REPLACEMENT OF RANCO LA2 LINEAR ACTUATORS AND HONEYWELL SPECIAL PACKAGED HVAC UNIT MOTORS

The M7164 Motors may be used for field replacement of Ranco LA2-1000 Series Zone Mixing Damper Actuators and LA2-2000 Series Modulating Heating Valve Actuators as described below. To select the appropriate model, refer to Table 1.

TABLE 1—CROSS REFERENCE OF RANCO AND HONEYWELL ELECTRONIC MOTORS.

Ranco Actuator Family	Input Voltage dc	Honeywell Motor Replacement		Linkage Required
LA2-1000 Zone Mixing Damper Actuator direct-action, spring return, nominal 35 lb [155.6N] force, 2 in.[50.8 mm] stroke.	10.5 to 13.5	M7161G1009 <sup>a,e</sup> M7164G1006 <sup>a,e</sup> M7164G1030 <sup>a,e</sup>	90 deg, 30 sec, 120 Vac, 19W, 35 lb-in. [4.0 N-m], electrically normally open <sup>c</sup> .	Q605, pushrod
		M7164A1017 <sup>a</sup>	90 deg, 30 sec, 24 Vac, 14W, 35 lb-in. [4.0 N-m], electrically normally closed <sup>c</sup> .	Q605, pushrod
LA2-2000 Modulating Heating Valve Actuator reverse-acting, spring return, nominal 35 lb [155.6 N] force, 2 in. [50.8 mm] stroke.	4.0 to 7.0	M7161G1017 <sup>b,e</sup> M7164G1014 <sup>b,e</sup>	90 deg, 30 sec, 120 Vac, 19W, 35 lb-in. [4.0 N-m], electrically normally open <sup>c</sup> .	Q100
		M7161G1025 <sup>d,e</sup> M7164G1022 <sup>d,e</sup>	160 deg, 60 sec, 24 Vac, 14W, 35 lb-in. [4.0 N-m], electrically normally open <sup>c</sup> .	Q601, Q618 or Q5001
		M7164A1009 <sup>d</sup>	160 deg, 60 sec, 24 Vac, 19W, 35 lb-in. [4.0 N-m], electrically normally closed <sup>c</sup> .	Q601, Q618 or Q5001

<sup>a</sup> New damper linkage and pushrod required.

<sup>b</sup> This motor is used with modulating gas valves (butterfly valves).

<sup>c</sup> On the Ranco Actuator, *electrical normal* is the position (extended = open; retracted = closed) of the actuator drive shaft (as viewed from the power end) when power is applied to the motor and input (command) signal is at the lowest point of the input voltage range.

<sup>d</sup> These motors are for use with modulating steam or hot water valves: valve and linkage replacement are required.

<sup>e</sup> This normally open motor provides *power end* damper linkage connection when space constraints prevent using a normally closed motor.

**Fig. 10—Replacing Ranco Linear Actuator with M7164 in a damper application. Use linkage (Q605 recommended) and pushrod to change from a linear to a circular force.**

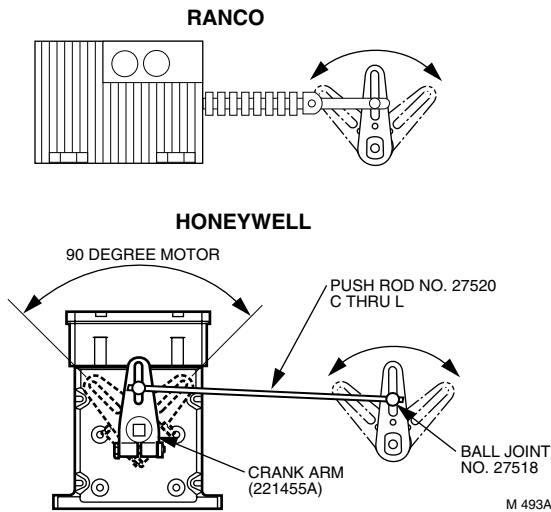

**MOUNTING IN A DAMPER APPLICATION**

Remove the Ranco Actuator and mount the M7164 replacement as shown in Fig. 10.

**MOUNTING IN A VALVE APPLICATION**

Remove the Ranco Actuator and linkage and install the appropriate linkage and Modutrol IV motor according to the instructions in the Installation section supplied with the linkage.

**WIRING CONVERSION**

Disconnect power supply before beginning installation to prevent electrical shock or equipment damage. All wiring must comply with local electrical codes, ordinances, and regulations.

To wire the M7161, M7164, proceed as follows. See Table 2. Disconnect power, then remove wiring from Ranco Actuator and connect to the motor according to Table 2 and Fig. 11.

TABLE 2—LA2-1000/2000 TO M7164 TERMINAL INTERCHANGES.

From Ranco LA2-1000/2000		To Honeywell M7161G, M7164A,G	
Terminal	Function	Terminal	Function
1—COMD (+)	+ command signal	C	+ signal
6—REF (—)	signal common	R	- common
9—24 Vac	power supply	L1 <sup>a</sup> or T1	power supply
10—24 Vac	power supply	L2 <sup>a</sup> or T2	—
		F <sup>b</sup>	

<sup>a</sup> Terminals L1 and L2 are used for 120 Vac motors. New power supply wiring must be run for 120 Vac motors.

<sup>b</sup> This terminal is not used when replacing Ranco Actuators.

Fig. 11—Wiring for replacement of Ranco LA2-1000/2000 Series Actuators with Honeywell 24V M7164A,G.

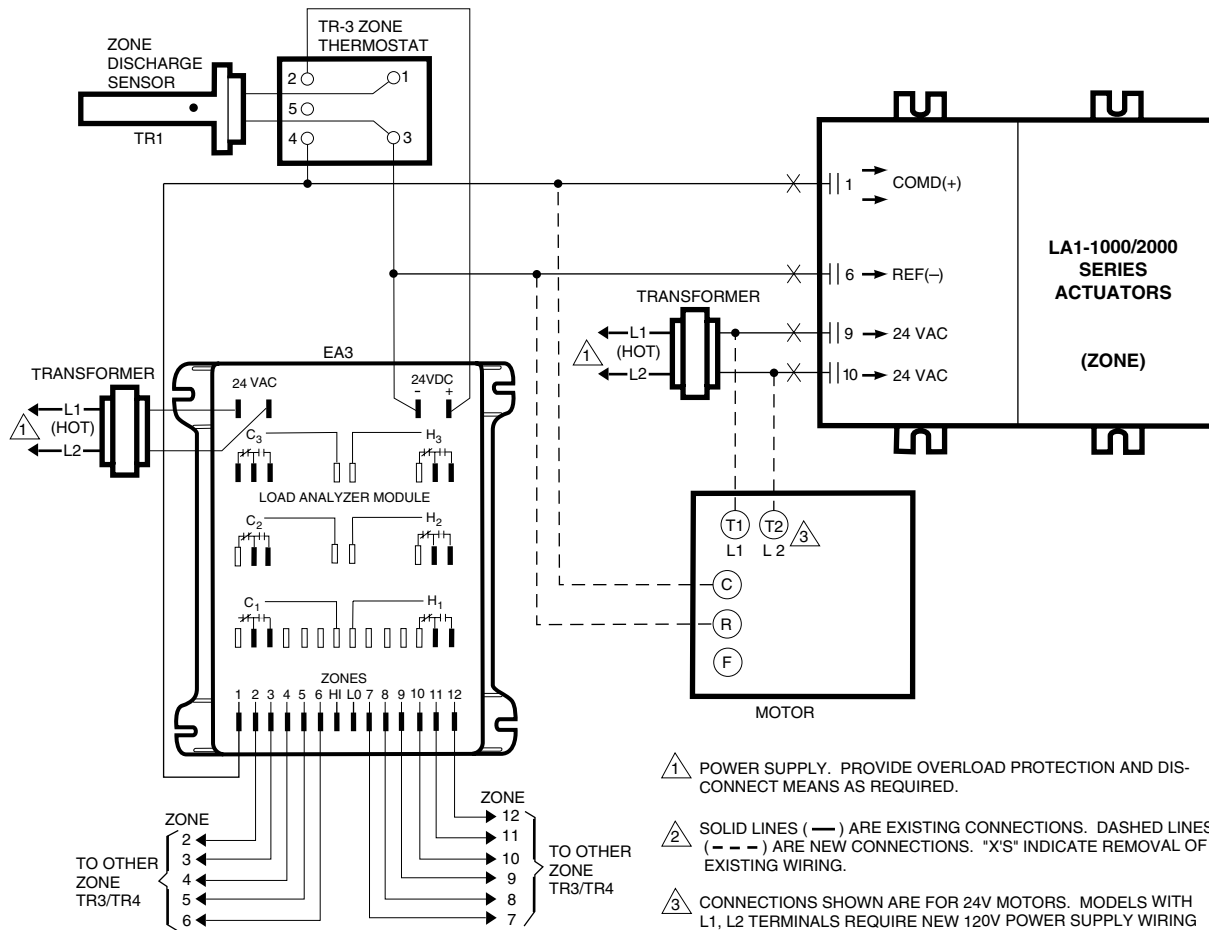

M3006

## Checkout



After installation and linkage adjustment, operate the motor through the thermostat or panel. Make sure that:

- The motor operates the damper or valve properly.
- The motor responds properly as input voltage is varied.
- The auxiliary switch, if used, operates at the desired point of motor rotation.



Inspect the motor, linkage, and valve or damper to see that all mechanical connections are correct and secure. In damper installations, the pushrod should not extend more than a few inches past the ball joints. Check to see that there is adequate clearance for the linkage to move through its stroke without binding or striking other objects. See System Instructions for additional checkout procedures.

### MOTOR OPERATION CHECK

M7161A,B, M7164A,B and M7184A

Jumper terminals C and F; motor should drive to the fully open (clockwise ) position as viewed from the power end. Remove jumper. Remove the lead from terminal C or R; motor should drive to the closed (fully counterclockwise ) position.

M7161G and M7164G

Jumper terminals C and F; motor should drive full closed (fully counterclockwise ) position as viewed from the power end). Remove jumper. Remove the lead from terminal C or R; motor should drive to the open (fully clockwise ) position.

# Honeywell

---

**Home and Building Control**

Honeywell Inc.  
1985 Douglas Drive North  
Golden Valley, Minnesota 55422

**Home and Building Control**

Honeywell Limited—Honeywell Limitée  
740 Ellesmere Road  
Scarborough, Ontario  
M1P 2V9

*Helping You Control Your World*



QUALITY IS KEY

Printed in U.S.A.