

# Honeywell

# Duct Temperature Averaging Sensors

C7021J, C7023J, C7031J, C7041J CABLE  
C7021R, C7023R, C7041R RIGID COPPER

## INSTALLATION INSTRUCTIONS

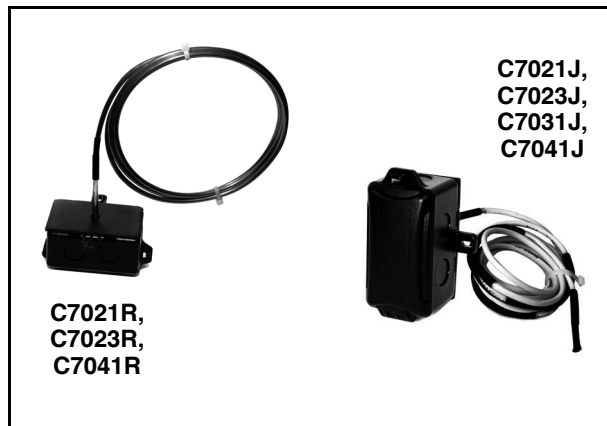

## MODEL SELECTION

Models are available to meet most application needs.

- C7021 - 10K Ohms NTC Type II
- C7023 - 10K Ohms NTC Type III
- C7031 - 10K PTC
- C7041 - 20K Ohms NTC

For a complete list of available sensors see the Sensors Product Overview brochure (form number 63-9285).

## MOUNTING

The C7021J, C7023J, C7031J, and C7041J Wire/Thermistor Averaging Sensors and the C7021R, C7023R, and C7041R Rigid Copper Averaging Sensors can be mounted in a duct to sense average air temperature.

### **IMPORTANT**

*Select a spot for the sensor to expose it to average duct air temperature. Avoid locations where stratification can cause sensing errors.*

## INSTALLATION

### **When Installing this Product...**

1. Read these instructions carefully. Failure to follow them could damage the product or cause a hazardous condition.
2. Check ratings given in instructions and on the product to ensure the product is suitable for your application.
3. Installer must be a trained, experienced service technician.
4. After installation is complete, check out product operation as provided in these instructions.

### **IMPORTANT**

*All wiring must agree with applicable codes, ordinances and regulations.*



62-0219-02

## C7021J, C7023J, C7031J, C7041J Mounting

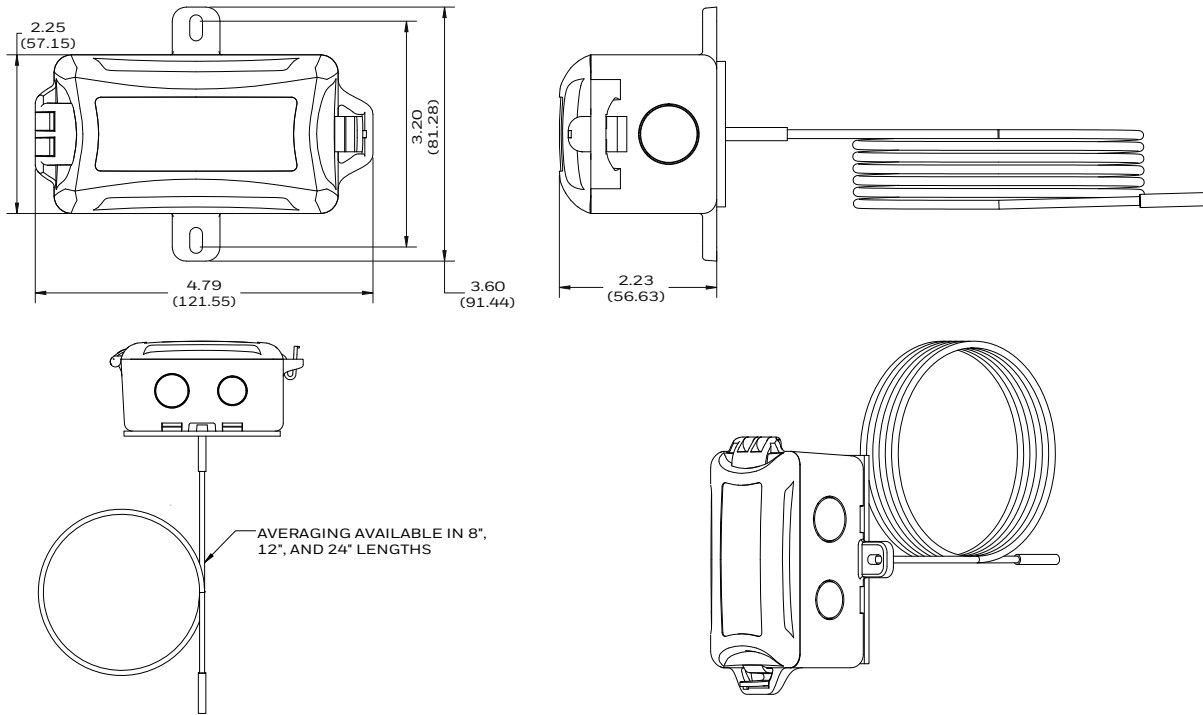

Fig. 1. C7021J, C7023J, C7031J, C7041J dimensions in in. (mm).

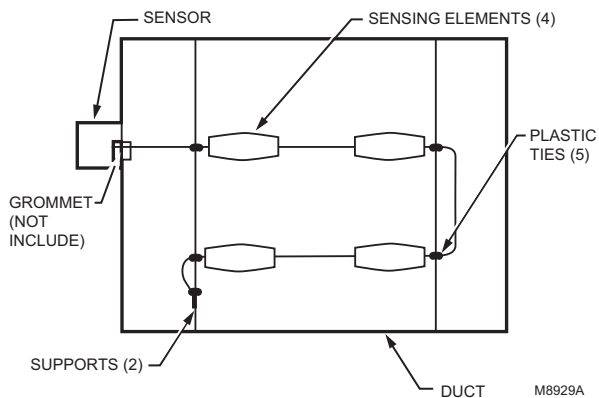

Fig. 2. Duct cross section showing method of installing C7021J, C7023J, C7031J, C7041J Averaging Electronic Sensor.

1. Install two supports inside the duct to hold the averaging element.
2. Cut a 7/8 in. (22 mm) hole in the side of the duct to insert the averaging element.
3. Fasten the terminal box to the outside of the duct and thread the element through the hole and into the duct.
4. Use plastic wire ties to fasten the element to the supports. Seal the hole around the element with a rubber grommet.
5. Secure the end of the element to the duct on the support to prevent continuous flexing or abrasion.

### IMPORTANT

To ensure that the C7021J/C7023J/C7031J/C7041J senses average duct temperature, position the temperature elements approximately as shown in Fig. 2. Do not allow the elements to touch or be close to the duct sides.

NOTE: When the sensor is used as a deck sensor in a multizone system, be sure to space the elements equally in the duct midstream as shown in Fig. 3.

Install one C7021J/C7023J/C7031J/C7041J just upstream from the cold deck zone dampers and the other C7021J/C7023J/C7031J/C7041J upstream from the hot deck zone dampers. Position the thermistors to sense the average deck temperature.

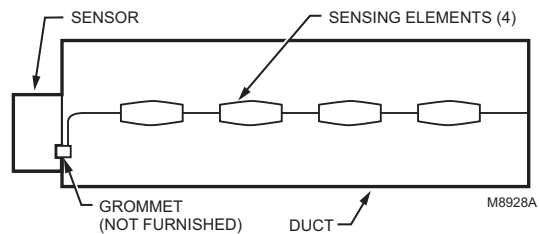
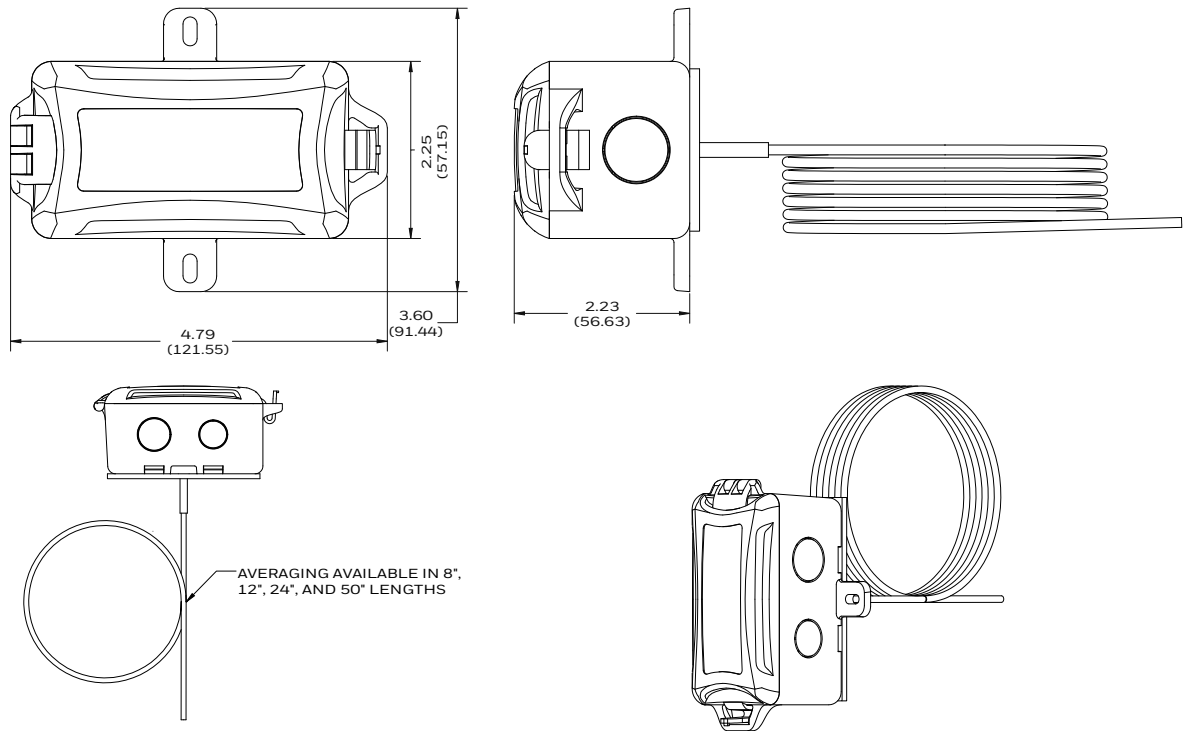

Fig. 3. Duct cross section showing method of installing C7021J, C7023J/C7031J/C7041J in a multizone system.

### C7021R, C7023R, C7041R Mounting



**Fig. 4. C7021R, C7023R, C7041R dimensions in in. (mm).**

1. Install two supports inside the duct to hold the averaging element.
2. Cut a 7/8 in. (22 mm) hole in the side of the duct.
3. Insert the averaging element into the duct through the hole.
4. Fasten the terminal box to the outside of the duct and thread the element through the hole and into the duct.
5. Use plastic wire ties to fasten the element to the supports. Seal the hole around the element with a rubber grommet.
6. Secure the end of the element to the duct on the support to prevent continuous flexing or abrasion.

**IMPORTANT**

To ensure that the C7021R, C7023R, C7041R senses average duct temperature, position the temperature elements approximately as shown in Fig. 5. Do not allow the elements to touch or be close to the duct sides.

NOTE: When the sensor is used as a deck sensor in a multizone system, be sure to space the elements equally in the duct midstream as shown in Fig. 6.

Install one C7021R, C7023R, C7041R just upstream from the cold deck zone dampers and the other C7021R, C7023R, C7041R upstream from the hot deck zone dampers. Position the thermistors to sense the average deck temperature.

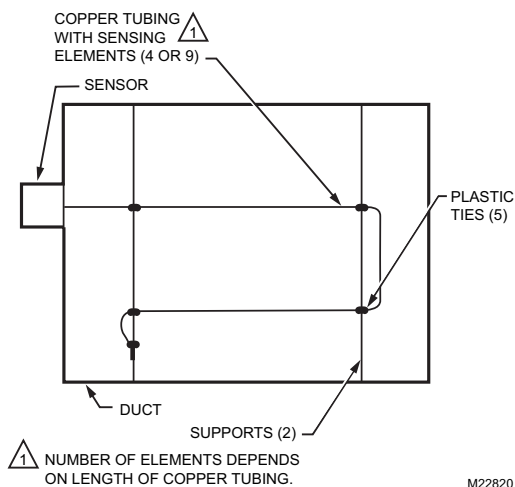

**Fig. 5. Duct cross section showing method of installing C7021R, C7023R, C7041R Averaging Electronic Sensor.**

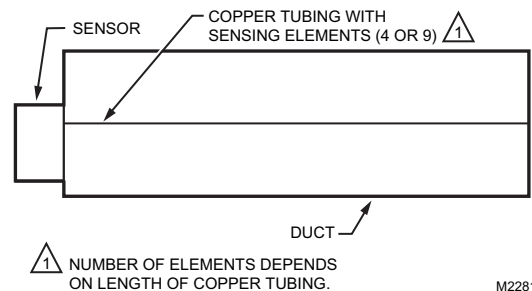

**Fig. 6. Duct cross section showing method of installing C7021R, C7023R, C7041R in a multizone system.**

**Honeywell Building Technologies**

In the U.S.:

Honeywell

715 Peachtree Street NE

Atlanta, GA 30308

[customer.honeywell.com](http://customer.honeywell.com)

[buildingcontrols.honeywell.com](http://buildingcontrols.honeywell.com)

® U.S. Registered Trademark  
©2021 Honeywell International Inc.  
62-0219-02 M.S. Rev. 01-21  
Printed in United States

**Honeywell**