

## Installation manual



## SmartVFD HVAC

Variable Frequency Drives  
for Variable Torque Applications

By using this Honeywell literature, you agree that Honeywell will have no liability for any damages arising out of your use or modification to, the literature. You will defend and indemnify Honeywell, its affiliates and subsidiaries, from and against any liability, cost, or damages, including attorneys' fees, arising out of, or resulting from, any modification to the literature by you.



**INDEX**

Document: DPD00323D  
Version release date: 18.1.18

<b>1. Safety</b> .....	<b>2</b>
1.1 Danger .....	2
1.2 Warnings .....	3
1.3 Grounding and ground fault protection .....	3
1.4 Running the motor .....	4
<b>2. Receipt of delivery</b> .....	<b>5</b>
2.1 'Product modified' sticker .....	5
2.2 Unpacking and lifting the drive .....	5
2.2.1 Lifting frames MR8 and MR9 .....	6
2.3 Type designation code .....	7
2.4 Accessories .....	8
<b>3. Mounting</b> .....	<b>9</b>
3.1 Dimensions .....	9
3.1.1 Wall mount, MR4-MR7 .....	9
3.1.2 Wall mount, MR8 and MR9 .....	11
3.1.3 Flange mount .....	12
3.2 Cooling .....	17
<b>4. Power cabling</b> .....	<b>19</b>
4.1 UL standards on cabling .....	20
4.1.1 Cable dimensioning and selection .....	20
4.2 Control cables .....	22
4.3 Cable installation .....	23
4.3.1 Frames MR4 to MR7 .....	23
4.3.2 Frames MR8 and MR9 .....	30
4.3.3 Cable and motor insulation checks .....	38
4.4 Installation in corner-grounded network .....	38
<b>5. Commissioning</b> .....	<b>39</b>
5.1 Commissioning of the SmartVFD HVAC .....	40
5.2 Changing EMC protection class .....	41
5.2.1 Frames MR4 to MR6 .....	41
5.2.2 Frames MR7 and MR8 .....	43
5.2.3 Frame MR9 .....	45
<b>6. Control unit</b> .....	<b>47</b>
6.1 Control Unit Cabling .....	48
6.1.1 Selection of the Control Cables .....	48
6.1.2 Control Terminals and Dip Switches .....	48
6.2 Fieldbus Connection .....	52
6.2.1 Using Fieldbus Through an Ethernet Cable .....	53
6.2.2 Using Fieldbus Through an RS485 Cable .....	55
6.3 Installation of Option Boards .....	59
6.4 Installation of a Battery for the Real Time Clock (RTC) .....	61
6.5 Galvanic Isolation Barriers .....	62
<b>7. Maintenance</b> .....	<b>63</b>
<b>8. Product data</b> .....	<b>64</b>
8.1 Power ratings .....	64

8.1.1 Mains voltage 208-240 V .....	64
8.1.2 Mains voltage 380-480V .....	65
8.1.3 Mains voltage 525-600V .....	66
8.1.4 Definitions of overloadability .....	67
8.2 SmartVFD HVAC - technical data .....	68
8.2.1 Technical information on control connections .....	71

# 1. SAFETY

This manual contains clearly marked cautions and warnings which are intended for your personal safety and to avoid any unintentional damage to the product or connected appliances.

**Please read the information included in cautions and warnings carefully.**

The cautions and warnings are marked as follows:



	= DANGEROUS VOLTAGE!
	= WARNING or CAUTION

Table 1. Warning signs

## 1.1 Danger



The **components of the power unit of the Smart VFD HVAC are live** when the drive is connected to mains potential. Coming into contact with this voltage is **extremely dangerous** and may cause death or severe injury.



The **motor terminals U, V, W and the brake resistor terminals are live** when the drive is connected to mains, even if the motor is not running.



**After disconnecting** the drive from the mains, **wait** until the indicators on the keypad go out (if no keypad is attached see the indicators on the cover). Wait 5 more minutes before doing any work on the connections of the drive. Do not open the cover before this time has expired. After expiration of this time, use a measuring equipment to absolutely ensure that no voltage is present. **Always ensure absence of voltage before starting any electrical work!**



The control I/O-terminals are isolated from the mains potential. However, the **relay outputs and other I/O-terminals may have a dangerous control voltage** present even when the drive is disconnected from mains.



**Before connecting** the drive to mains make sure that the front and cable covers of the drive are closed.



During a ramp stop (see the Application Manual), the motor is still generating voltage to the drive. Therefore, do not touch the components of the drive before the motor has completely stopped. Wait until the indicators on the keypad go out (if no keypad is attached see the indicators on the cover). Wait additional 5 minutes before starting any work on the drive.

## 1.2 Warnings



The Honeywell Smart VFD HVAC is meant for **fixed installations only**.



**Do not perform any measurements** when the drive is connected to the mains.



The **touch current** of the Honeywell Smart VFD HVAC exceeds 3.5mA AC. According to standard EN61800-5-1, a **reinforced protective ground connection** must be ensured. See chapter 1.3.



If the drive is used as a part of a machine, the **machine manufacturer is responsible** for providing the machine with a **supply disconnecting device** (EN 60204-1).



Only **spare parts** delivered by Honeywell can be used.



At power-up, power brake, or fault reset **the motor will start immediately** if the start signal is active, unless the pulse control for Start/Stop logic has been selected. Furthermore, the I/O functionalities (including start inputs) may change if parameters, applications or software are changed. Disconnect, therefore, the motor if an unexpected start can cause danger.



The **motor starts automatically** after automatic fault reset if the autoreset function is activated. See the Application Manual for more detailed information.



**Prior to measurements on the motor or the motor cable**, disconnect the motor cable from the drive.



**Do not touch the components on the circuit boards**. Static voltage discharge may damage the components.



Check that the **EMC level** of the drive corresponds to the requirements of your supply network. See chapter 5.2.



In a domestic environment, this product may cause radio interference in which case supplementary mitigation measures may be required.

## 1.3 Grounding and ground fault protection



### CAUTION!

The Honeywell Smart VFD HVAC AC drive must always be grounded with an grounding conductor connected to the grounding terminal marked with .

The touch current of the drive exceeds 3.5mA AC. According to EN61800-5-1, one or more of the following conditions for the associated protective circuit shall be satisfied:

1. A fixed connection and
  - a) the **protective earthing conductor** has a cross-sectional area of at least 6 AWG (10 mm<sup>2</sup>) Cu or 4 AWG (16 mm<sup>2</sup>) Al through its total run.
  - b) an automatic disconnection of the supply in case of loss of continuity of the protective conductor. See chapter 4.

- c) provision of an additional terminal for a second **protective earthing conductor** of the same cross-sectional area as the original **protective earthing conductor**.

OR

2. Connection with an industrial connector according to IEC 60309 and a minimum **protective earthing connector** cross-section of 12 AWG (2.5 mm<sup>2</sup>) as part of a multi-conductor power cable. Adequate strain relief shall be provided.

**NOTE:** Due to the high capacitive currents present in the drive, fault current protective switches may not function properly.



**Do not perform any voltage withstand tests** on any part of the drive. There is a certain procedure according to which the tests shall be performed. Ignoring this procedure may result in damaged product.

---

## 1.4 Running the motor

### MOTOR RUN CHECK LIST



**Before starting the motor**, check that the motor is **mounted properly** and ensure that the machine connected to the motor allows the motor to be started.



Set the maximum motor speed (frequency) according to the motor and the machine connected to it.



**Before reversing the motor** make sure that this can be done safely.



Make sure that no power correction capacitors are connected to the motor cable.



Make sure that the motor terminals are not connected to mains potential.

**NOTE!** You can download the English and French product manuals with applicable safety, warning and caution information from <https://customer.honeywell.com/en-US/Pages/default.aspx>.

**REMARQUE** Vous pouvez télécharger les versions anglaise et française des manuels produit contenant l'ensemble des informations de sécurité, avertissements et mises en garde applicables sur le site <https://customer.honeywell.com/en-US/Pages/default.aspx>.

## 2. RECEIPT OF DELIVERY

Check the correctness of delivery by comparing your order data to the drive information found on the package label. If the delivery does not correspond to your order, contact the supplier immediately. See chapter 2.3.

### 2.1 'Product modified' sticker

In the small plastic bag included with delivery you will find a silver *Product modified* sticker. The purpose of the sticker is to notify the service personnel about the modifications made in the drive. Attach the sticker on the side of the drive to avoid losing it. Should the drive be later modified mark the change on the sticker.

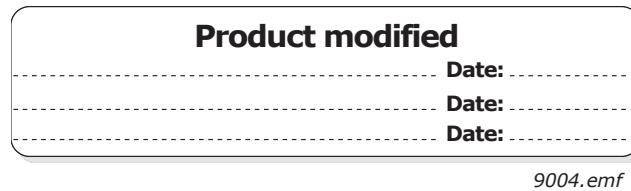

Figure 1. 'Product modified' sticker

### 2.2 Unpacking and lifting the drive

The weights of the drives vary greatly according to the size. You may need to use a piece of special lifting equipment to remove the drive from its package. Note the weights of each individual frame size in Table 2 below.

Frame	Weight [kg]	Weight [lb.]
MR4	6.0	13.2
MR5	10.0	22.0
MR6	20.0	44.1
MR7	37.5	82.7
MR8	70.0	154.3
MR9	108.0	238.1

Table 2. Frame weights

If you decide to use a piece of lifting equipment see picture below for recommendations to lift the drive.

### 2.2.1 Lifting frames MR8 and MR9

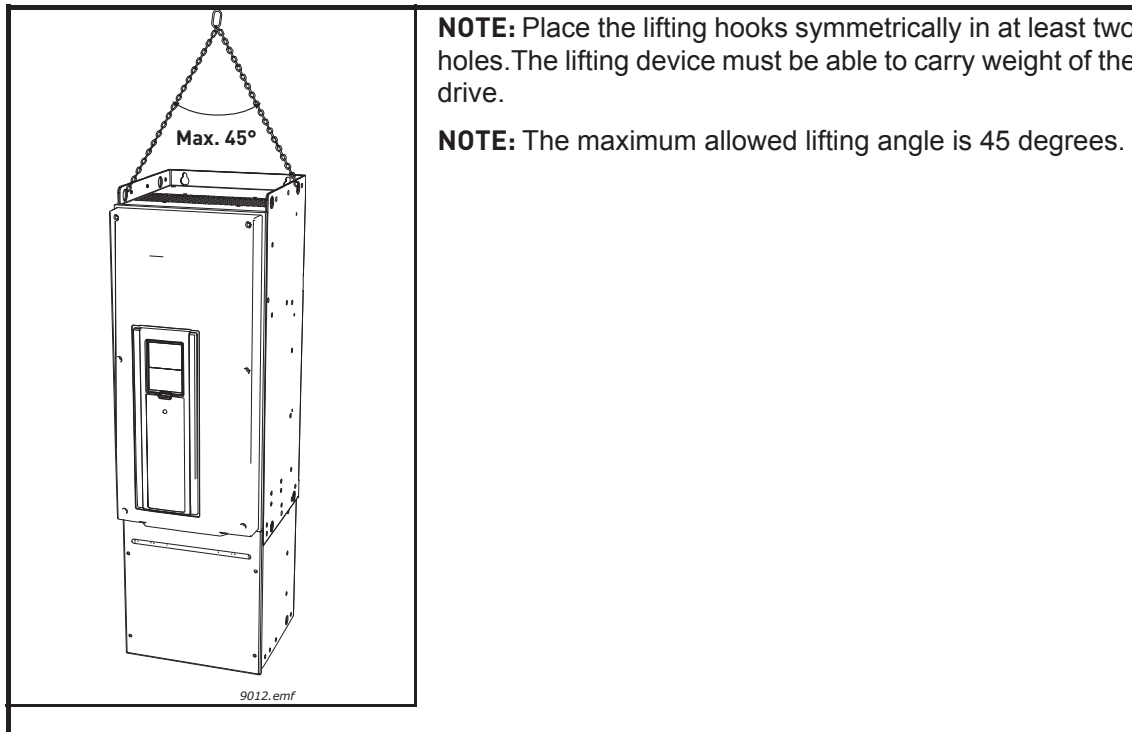

Figure 2. Lifting bigger frames

The Honeywell Smart VFD HVAC undergoes scrupulous tests and quality checks at the factory before it is delivered to the customer. However, after unpacking the product, check that no signs of transport damages are to be found on the product and that the delivery is complete.

Should the drive have been damaged during the shipping, please contact primarily the cargo insurance company or the carrier.



### 2.3 Type designation code

Honeywell type designation code is formed of a four-segment code. Each segment of the type designation code uniquely corresponds to the product and options you have ordered. The code is of the following format:

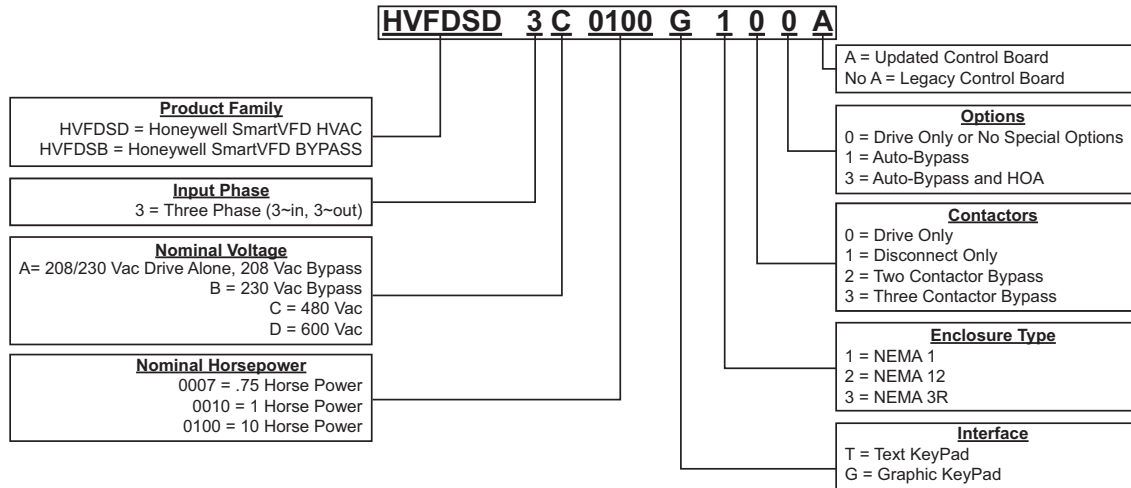

## 2.4 Accessories

After having opened the transport package and lifted the converter out, check immediately that these various accessories were included in the delivery:

- Rubber grommets (sizes vary according to frame)
- Power cable clamps for EMC grounding
- Screws for fixing the power cable clamps
- Control cable grounding clamps
- M4 screw for EMC level change in frame MR7
- Additional grounding screw (if necessary, see chapter 1.3)
- Ferrite holder
- Optional plastic shield to prevent unintended contact with live parts from front (MR8 and MR9, IP00)

### 3. MOUNTING

The drive must be mounted in vertical position on the wall. Ensure that the mounting plane is relatively even.

The drive shall be fixed with four screws (or bolts, depending on the unit size).

#### 3.1 Dimensions

##### 3.1.1 Wall mount, MR4-MR7

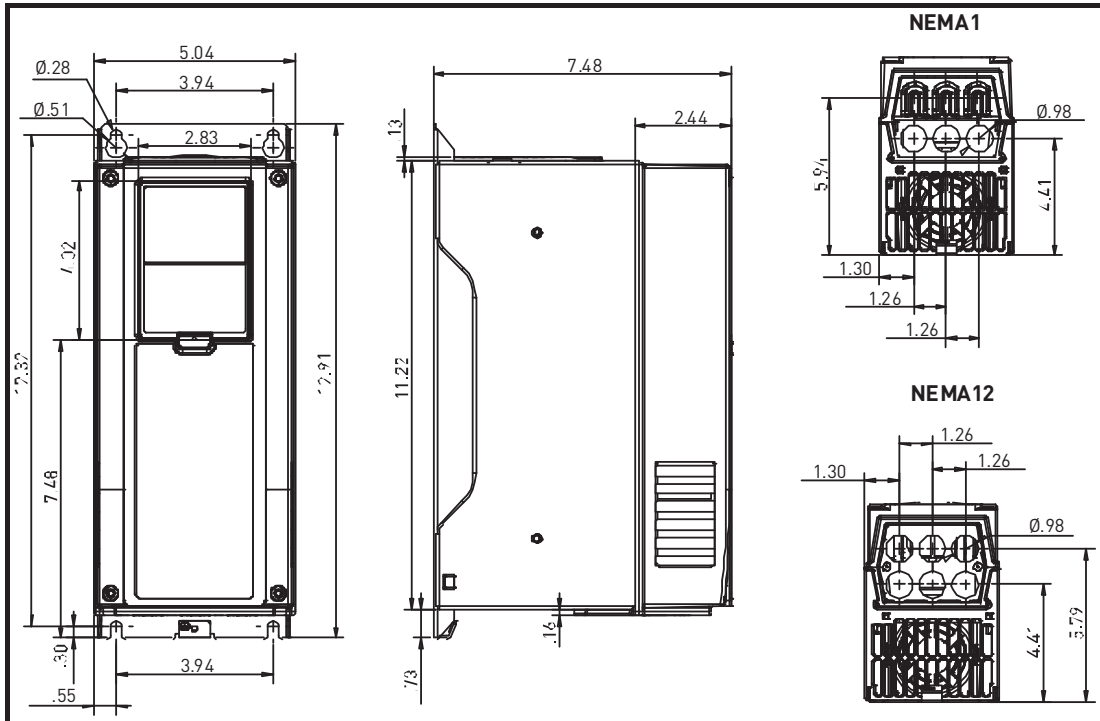

Figure 3. SmartVFD HVAC dimensions, MR4, wall mount



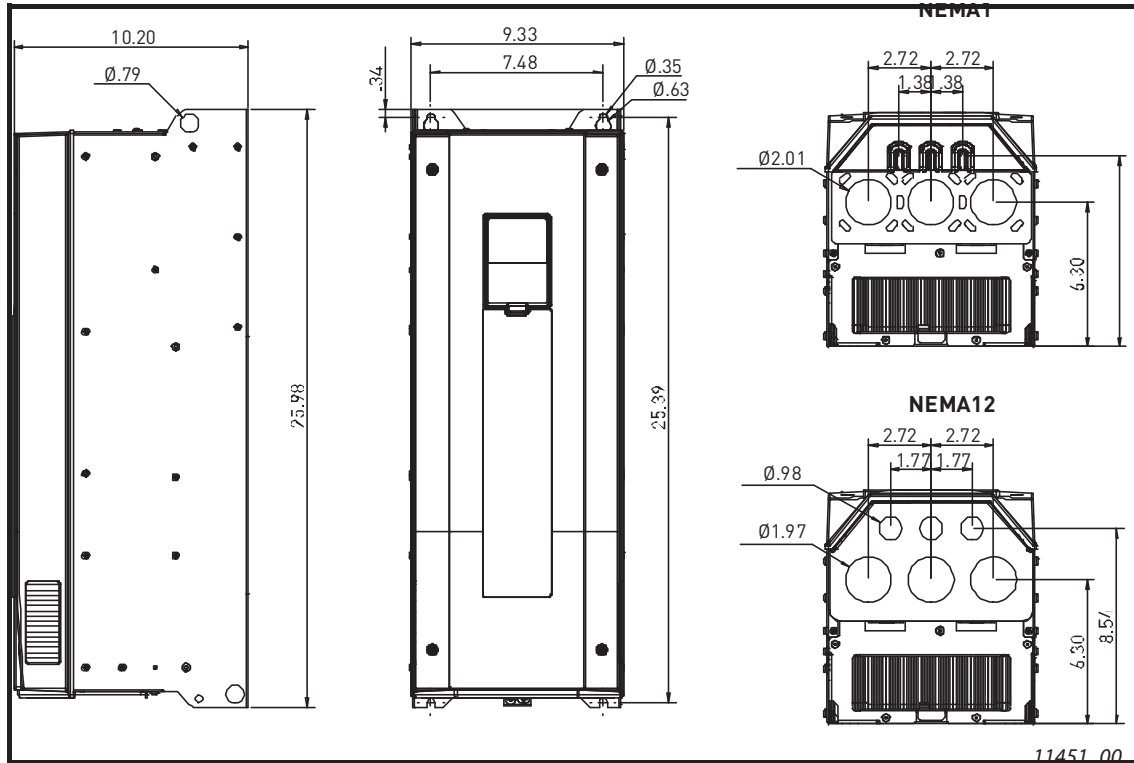

Figure 6. SmartVFD HVAC dimensions, MR7, wall mount

### 3.1.2 Wall mount, MR8 and MR9

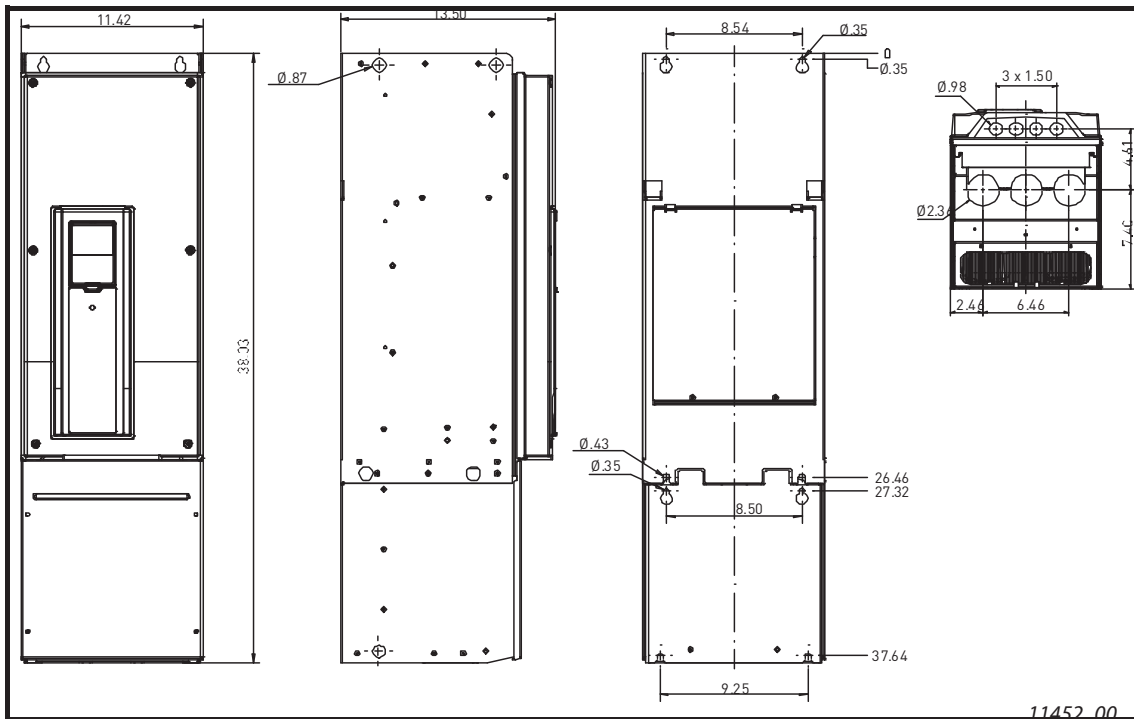

Figure 7. AC drive dimensions, MR8 NEMA1 and NEMA12

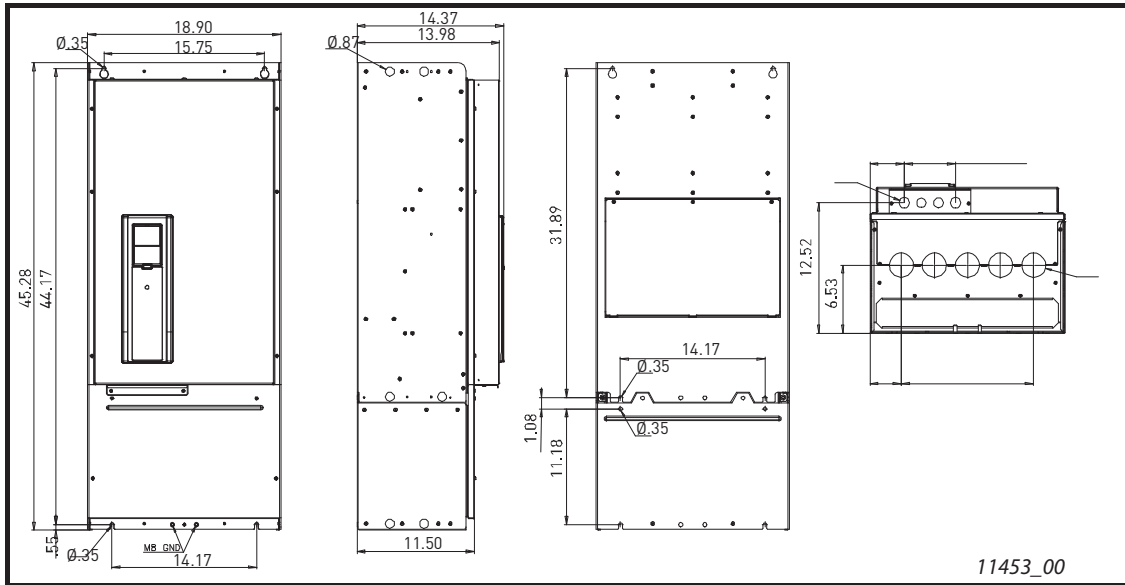

Figure 8. AC drive dimensions, MR9 NEMA1 and NEMA12 (preliminary)

### 3.1.3 Flange mount

The AC drive can also be recessed into the cabinet wall or similar surface. A special flange mount option is available for this purpose. For an example of a flange-mounted drive, see Figure 9.

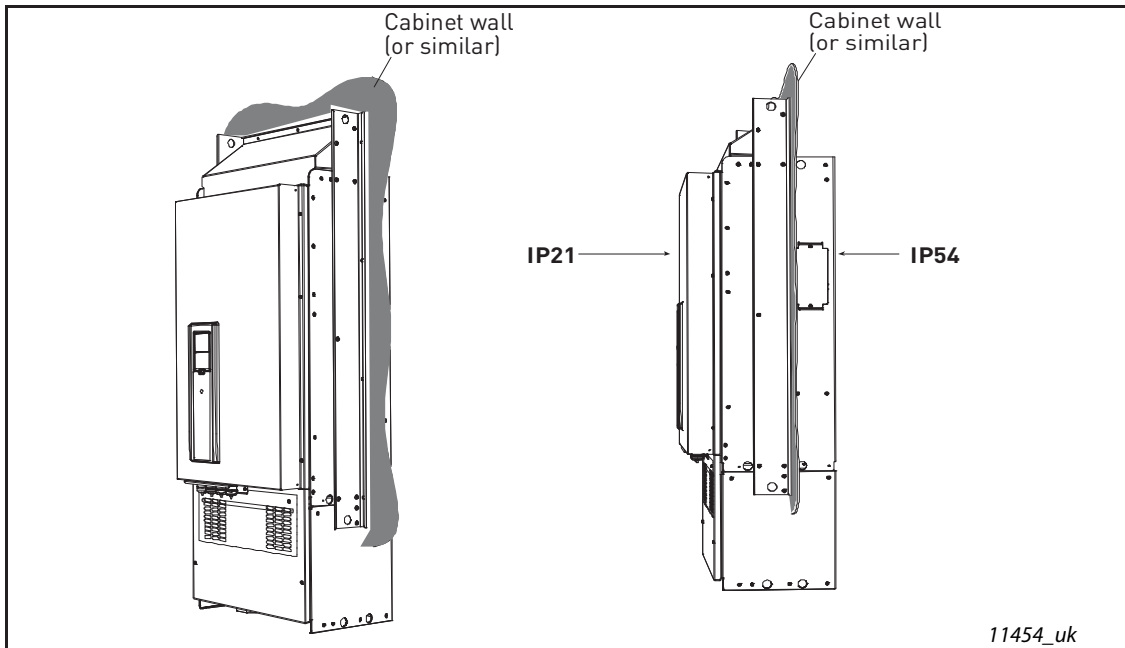

Figure 9. Example of flange mount (frame MR9)

**3.1.3.1 Flange mount - Frames MR4 to MR6**

Figure 10. presents the dimensions of the mounting opening and Figure 11. the depth dimensions of the drives with the flange mount option.

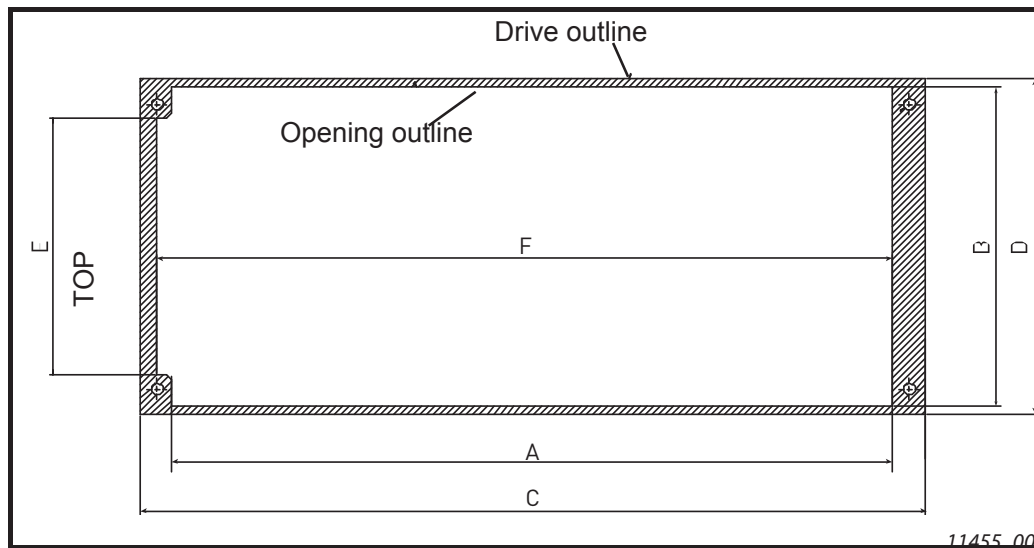

Figure 10. Flange mount cutout dimensions for MR4 to MR6

Frame	A	B	C	D	E	F
MR4	12.20	5.39	13.27	5.67	4.33	12.44
MR5	16.06	5.98	17.09	6.30	5.20	16.30
MR6	21.02	7.99	22.05	8.31	7.24	21.30

Table 3. Flange mount cutout dimensions for MR4 to MR6 [in]

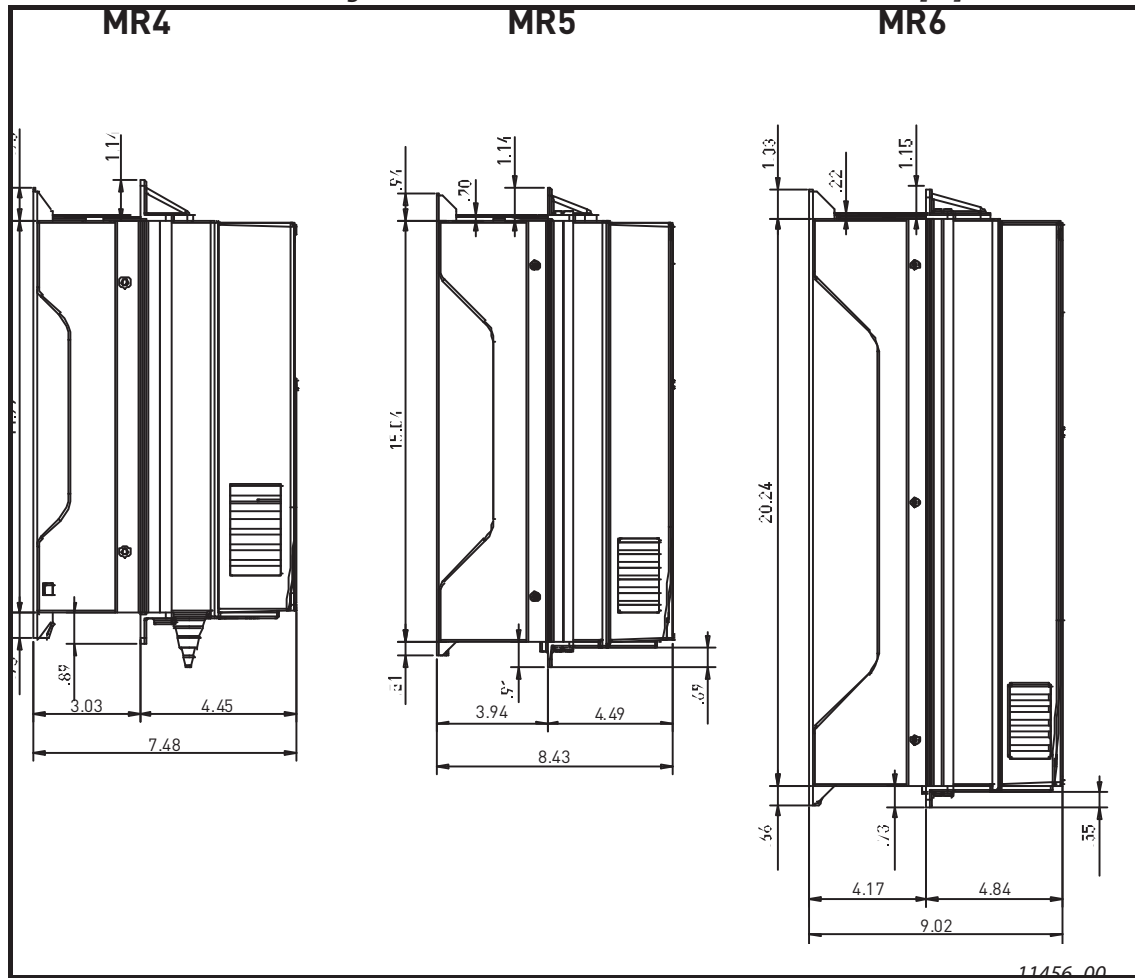

Figure 11. MR4 to MR6, flange mount, depth dimensions



**3.1.3.2 Flange mount MR7 to MR9**

Figure 12. presents the dimensions of the mounting opening and Figure 13. the dimensions of the drives with the flange mount option.

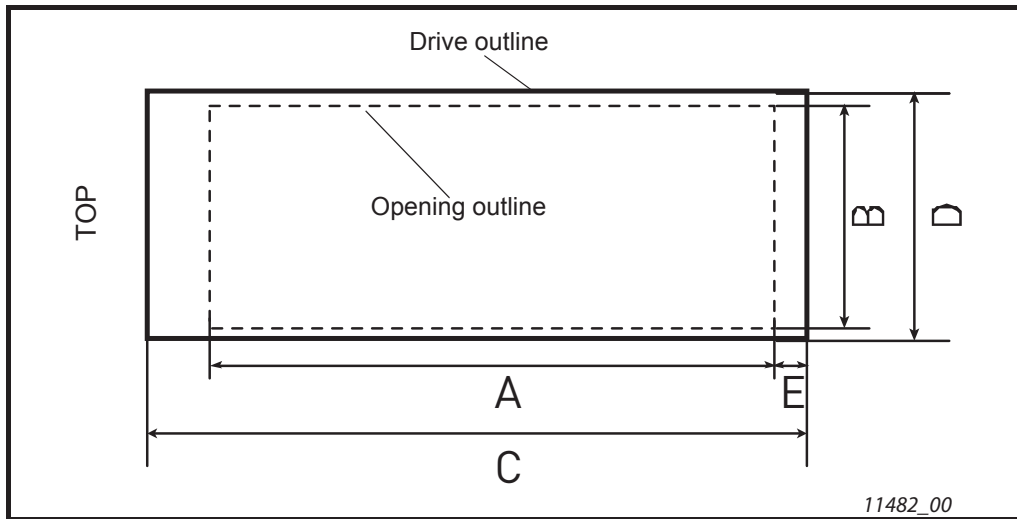

Figure 12. Flange mount cutout dimensions for MR7 to MR9

Frame	A	B	C	D	E
MR7	25.79	9.45	26.85	10.55	.53
MR8	33.82	11.73	34.96	14.13	.67
MR9	38.39	19.09	41.34	20.87	2.13

Table 4. Flange mount cutout dimensions for MR7 to MR9 [in]

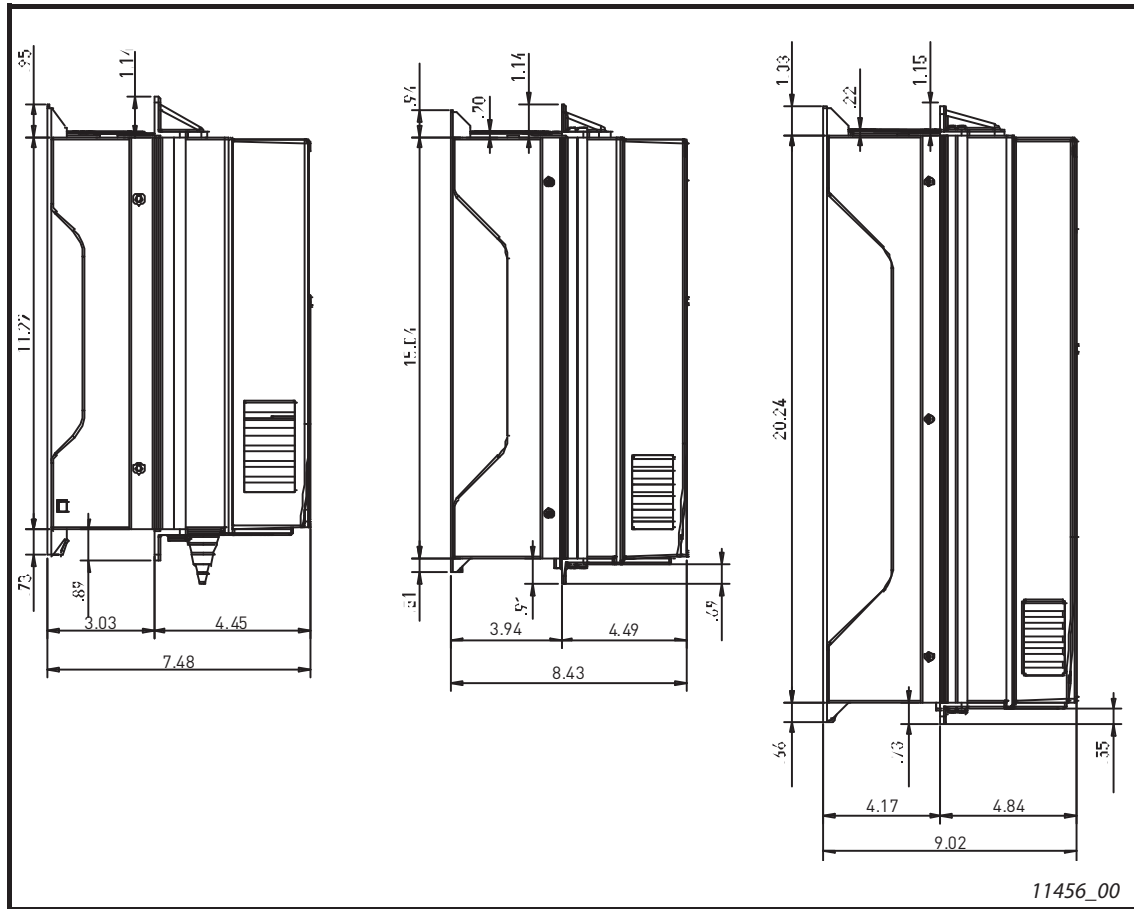
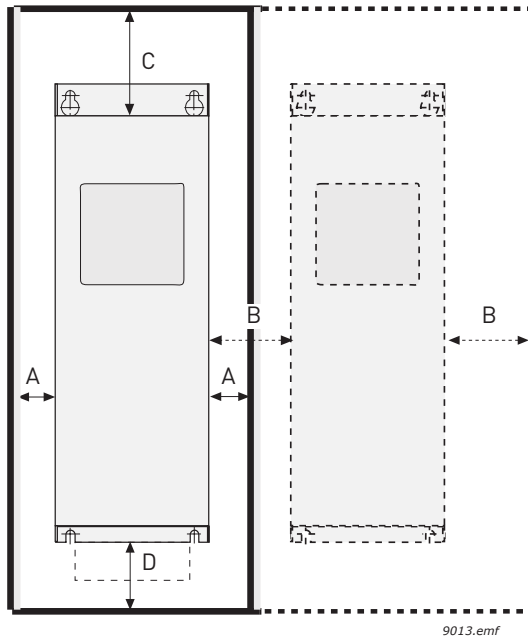

Figure 13. MR7 to MR9, flange mount, depth dimensions

### 3.2 Cooling

The drive produces heat in operation and is cooled by air circulated by a fan. Enough free space needs to be left around the drive to ensure sufficient air circulation and cooling. Different acts of maintenance also require a certain amount of free space.

Make sure that the temperature of the cooling air does not exceed the maximum ambient temperature of the converter.



Min clearance [in], NEMA1				
Type	A*	B*	C	D
MR4	.79	.79	3.94	1.97
MR5	.79	.79	4.72	2.36
MR6	.79	.79	6.30	3.15
MR7	.79	.79	9.84	3.94
MR8	.79	.79	11.8	5.91
MR9	.79	.79	13.78	7.87

\*. Min clearances A and B for drives with IP54 enclosure is 0 in.

Table 5. Min. clearances around drive

Figure 14. Installation space

- A = clearance around the drive (see also B)
- B = distance from one drive to another or distance to cabinet wall
- C = free space above the drive
- D = free space underneath the drive

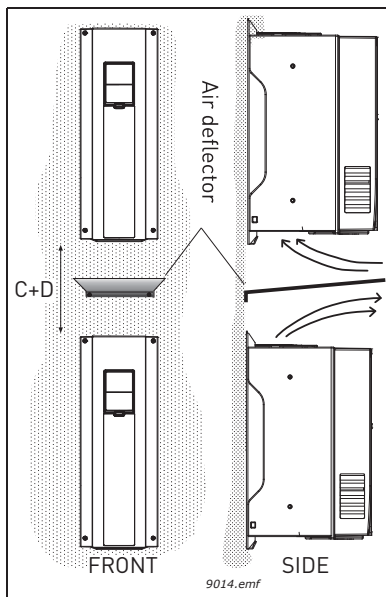

Note that if several units are mounted above one another the required free space equals C + D (see Figure 15.). Moreover, the outlet air used for cooling by the lower unit must be directed away from the air intake of the upper unit.

Figure 15. Installation space when drives are mounted on top of each other

Type	Cooling air required [cfm]
MR4	26
MR5	44
MR6	112
MR7	109
MR8	197
MR9	366

Table 6. Required cooling air

## 4. POWER CABLING

The mains cables are connected to terminals L1, L2 and L3 and the motor cables to terminals marked with U, V and W. See Table 7 for the cable recommendations for different EMC levels.

Use cables with heat resistance of at least +158°F. The cables and the fuses must be dimensioned according to the drive nominal OUTPUT current which you can find on the rating plate.

Cable type	EMC levels According to EN61800-3 (2004)		
	1 <sup>st</sup> environment	2nd environment	
	Category C2	Category C3	Level T
Mains cable	1	1	1
Motor cable	3*	2	2
Control cable	4	4	4

Table 7. Cable types required to meet standards

- 1 = Power cable intended for fixed installation and the specific mains voltage. Shielded cable not required. (MCMK or similar recommended).
- 2 = Symmetrical power cable equipped with concentric protection wire and intended for the specific mains voltage. (MCMK or similar recommended). See Figure 16.
- 3 = Symmetrical power cable equipped with compact low-impedance shield and intended for the specific mains voltage. [MCCMK, EMCMK or similar recommended; Recommended cable transfer impedance (1...30MHz) max. 100mohm/m]. See Figure 16.  
\*360° grounding of the shield with cable glands in motor end needed for EMC level C2.
- 4 = Screened cable equipped with compact low-impedance shield (JAMAK, SAB/ÖZCuY-O or similar).

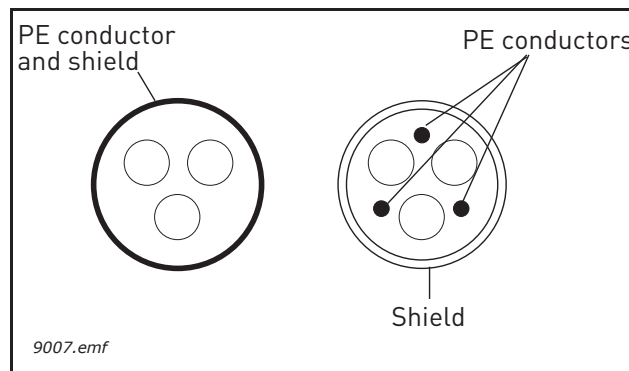

Figure 16.

**NOTE:** The EMC requirements are fulfilled at factory defaults of switching frequencies (all frames).

**NOTE:** If safety switch is connected the EMC protection shall be continuous over the whole cable installation.

## 4.1 UL standards on cabling

To meet the UL (Underwriters Laboratories) regulations, use a UL-approved copper cable with a minimum heat-resistance of +140/167°F. Use Class 1 wire only.

The units are suitable for use on a circuit capable of delivering not more than 100,000 rms symmetrical amperes, 600V maximum.

### 4.1.1 Cable dimensioning and selection

Table 8 shows the minimum dimensions of the Cu/Al-cables and the corresponding fuse sizes. Recommended fuse types are gG/gL.

These instructions apply only to cases with one motor and one cable connection from the drive to the motor. In any other case, ask the factory for more information.

#### 4.1.1.1 Cable and fuse sizes, frames MR4 to MR6, North America

The recommended fuse types are gG/gL (IEC 60269-1) or class T (UL & CSA). The fuse voltage rating should be selected according to the supply network. The final selection should be made according to local regulations, cable installation conditions and cable specification. Bigger fuses than what is recommended below shall not be used.

Check that the fuse operating time is less than 0.4 seconds. Operating time depends on used fuse type and impedance of the supply circuit. Consult the factory about faster fuses. Honeywell offers recommendations also for high speed J (UL & CSA), aR (UL recognized, IEC 60269-4) and gS (IEC 60269-4) fuse ranges.

Frame	Type*	$I_L$ [A]	Fuse (class T) [A]	Mains, motor and ground cable Cu	Terminal cable size	
					Main terminal	Ground terminal
MR4	A007	3.7	6	AWG14	AWG24-AWG10	AWG17-AWG10
	A0010	4.8	6	AWG14	AWG24-AWG10	AWG17-AWG10
	A0015	6.6	10	AWG14	AWG24-AWG10	AWG17-AWG10
	A0020	8	10	AWG14	AWG24-AWG10	AWG17-AWG10
	A0030	11	15	AWG14	AWG24-AWG10	AWG17-AWG10
	A0040	12.5	20	AWG14	AWG24-AWG10	AWG17-AWG10
	C 0015	3.4	6	AWG14	AWG24-AWG10	AWG17-AWG10
	C 0020	4.8	6	AWG14	AWG24-AWG10	AWG17-AWG10
	C 0030	5.6	10	AWG14	AWG24-AWG10	AWG17-AWG10
	C 0040	8.0	10	AWG14	AWG24-AWG10	AWG17-AWG10
	C 0050	9.6	15	AWG14	AWG24-AWG10	AWG17-AWG10
	C 0075	12.0	20	AWG14	AWG24-AWG10	AWG17-AWG10

Frame	Type*	$I_L$ [A]	Fuse (class T) [A]	Mains, motor and ground cable Cu	Terminal cable size	
					Main terminal	Ground terminal
MR5	A0050	18	25	AWG10	AWG20-AWG5	AWG17-AWG8
	A0075	24.2	30	AWG10	AWG20-AWG5	AWG17-AWG8
	A0100	31	40	AWG8	AWG20-AWG5	AWG17-AWG8
	C 0100	16.0	25	AWG10	AWG20-AWG5	AWG17-AWG8
	C 0150	23.0	30	AWG10	AWG20-AWG5	AWG17-AWG8
	C 0200	31.0	40	AWG8	AWG20-AWG5	AWG17-AWG8
	D0030	3.9	6	AWG14	AWG20-AWG5	AWG17-AWG8
	D0050	6.1	10	AWG14	AWG20-AWG5	AWG17-AWG8
	D0075	9	10	AWG14	AWG20-AWG5	AWG17-AWG8
	D0100	11	15	AWG14	AWG20-AWG5	AWG17-AWG8
MR6	A0150	48	60	AWG4	AWG13-AWG0	AWG13-AWG2
	A0200	62	80	AWG4	AWG13-AWG0	AWG13-AWG2
	C 0250	38.0	50	AWG4	AWG13-AWG0	AWG13-AWG2
	C 0300	46.0	60	AWG4	AWG13-AWG0	AWG13-AWG2
	C 0400**	61.0	80	AWG4	AWG13-AWG0	AWG13-AWG2
	D0150	18	20	AWG10	AWG13-AWG0	AWG13-AWG2
	D0200	22	25	AWG10	AWG13-AWG0	AWG13-AWG2
	D0250	27	30	AWG8	AWG13-AWG0	AWG13-AWG2
	D0300	34	40	AWG8	AWG13-AWG0	AWG13-AWG2

\*. For more information on type code, see page 7.

\*\* The 460V models require 90-degree wire to meet UL regulations

Table 8. Cable and fuse sizes for Honeywell Smart VFD HVAC (MR4 to MR6)

The cable dimensioning is based on the criteria of the Underwriters' Laboratories UL508C: Cables must be PVC-isolated; Max ambient temperature +86°F, max temperature of cable surface +158°F; Use only cables with concentric copper shield; Max number of parallel cables is 9.

When using cables in parallel, **NOTE HOWEVER** that the requirements of both the cross-sectional area and the max number of cables must be observed.

For important information on the requirements of the grounding conductor, see standard Underwriters' Laboratories UL508C.

For the correction factors for each temperature, see the instructions of standard Underwriters' Laboratories UL508C.

#### 4.1.1.2 Cable and fuse sizes, frames MR7 to MR9, North America

The recommended fuse types are gG/gL (IEC 60269-1) or class T (UL & CSA). The fuse voltage rating should be selected according to the supply network. The final selection should be made according to local regulations, cable installation conditions and cable specification. Bigger fuses than what is recommended below shall not be used.

Check that the fuse operating time is less than 0.4 seconds. Operating time depends on used fuse type and impedance of the supply circuit. Consult the factory about faster fuses. Honeywell offers recommendations also for high speed J (UL & CSA), aR (UL recognized, IEC 60269-4) and gS (IEC 60269-4) fuse ranges.

Frame	Type	I <sub>L</sub> [A]	Fuse (class T) [A]	Mains, motor and ground cable Cu	Terminal cable size	
					Main terminal	Ground terminal
MR7	A0250	75	100	AWG2	AWG9-AWG2/0	AWG9-AWG2/0
	A0300	88	110	AWG1	AWG9-AWG2/0	AWG9-AWG2/0
	A0400	105	150	AWG1/0	AWG9-AWG2/0	AWG9-AWG2/0
	C 0500	72.0	100	AWG2	AWG9-AWG2/0	AWG9-AWG2/0
	C 0600	87.0	110	AWG1	AWG9-AWG2/0	AWG9-AWG2/0
	C 0750	105.0	150	AWG1/0	AWG9-AWG2/0	AWG9-AWG2/0
	D0400	41	50	AWG6	AWG9-AWG2/0	AWG9-AWG2/0
	D0500	52	60	AWG6	AWG9-AWG2/0	AWG9-AWG2/0
	D0600	62	70	AWG4	AWG9-AWG2/0	AWG9-AWG2/0
MR8	A0500	143	200	AWG3/0	AWG1-350kcmil	AWG1-350kcmil
	A0600	170	225	250kcmil	AWG1-350kcmil	AWG1-350kcmil
	A0750	208	250	350kcmil	AWG1-350kcmil	AWG1-350kcmil
	C 1000	140.0	200	AWG3/0	AWG1-350 kcmil	AWG1-350 kcmil
	C 1250	170.0	225	250 kcmil	AWG1-350 kcmil	AWG1-350 kcmil
	C 1500	205.0	250	350 kcmil	AWG1-350 kcmil	AWG1-350 kcmil
	D0750	80	90	AWG1/0	AWG1-350kcmil	AWG1-350kcmil
	D1000	100	110	AWG1/0	AWG1-350kcmil	AWG1-350kcmil
	D1250	125	150	AWG2/0	AWG1-350kcmil	AWG1-350kcmil
MR9	A1000	261	350	2x250kcmil	AWG1-350kcmil	AWG1-350kcmil
	A1250	310	400	2x350kcmil	AWG1-350kcmil	AWG1-350kcmil
	C 2000	261.0	350	2*250 kcmil	AWG1-350 kcmil	AWG1-350 kcmil
	C 2500	310.0	400	2*350 kcmil	AWG1-350 kcmil	AWG1-350 kcmil
	D1500	144	175	AWG3/0	AWG1-350kcmil	AWG1-350kcmil
	D2000	208	250	300kcmil	AWG1-350kcmil	AWG1-350kcmil

Table 9. Cable and fuse sizes for Honeywell Smart VFD HVAC (MR7 to MR9)

The cable dimensioning is based on the criteria of the Underwriters' Laboratories UL508C: Cables must be PVC-isolated; Max ambient temperature +86°F, max temperature of cable surface +158°F; Use only cables with concentric copper shield; Max number of parallel cables is 9.

When using cables in parallel, **NOTE HOWEVER** that the requirements of both the cross-sectional area and the max number of cables must be observed.

For important information on the requirements of the grounding conductor, see standard Underwriters' Laboratories UL508C.

For the correction factors for each temperature, see the instructions of standard Underwriters' Laboratories UL508C.

## 4.2 Control cables

For information on control cables see chapter 6.



### 4.3 Cable installation

- Before starting, check that none of the components of the drive is live. Read carefully the warnings in chapter 1.
- Place the motor cables sufficiently far from other cables
- Avoid placing the motor cables in long parallel lines with other cables.
- If the motor cables run in parallel with other cables note the minimum distances between the motor cables and other cables given in table below.

Distance between cables, [in]	Shielded cable, [ft]
11.8	≤ 164
39.4	≤ 656

- The given distances also apply between the motor cables and signal cables of other systems.
- The maximum lengths of motor cables are 328 ft. (MR4), 492 ft. (MR5 and MR6) and 656 ft. (MR7 to MR9).
- The motor cables should cross other cables at an angle of 90 degrees.
- If cable insulation checks are needed, see chapter Cable and motor insulation checks.

Start the cable installation according to the instructions below:

#### 4.3.1 Frames MR4 to MR7

<b>1</b>	Strip the motor and mains cables as advised below.
----------	--

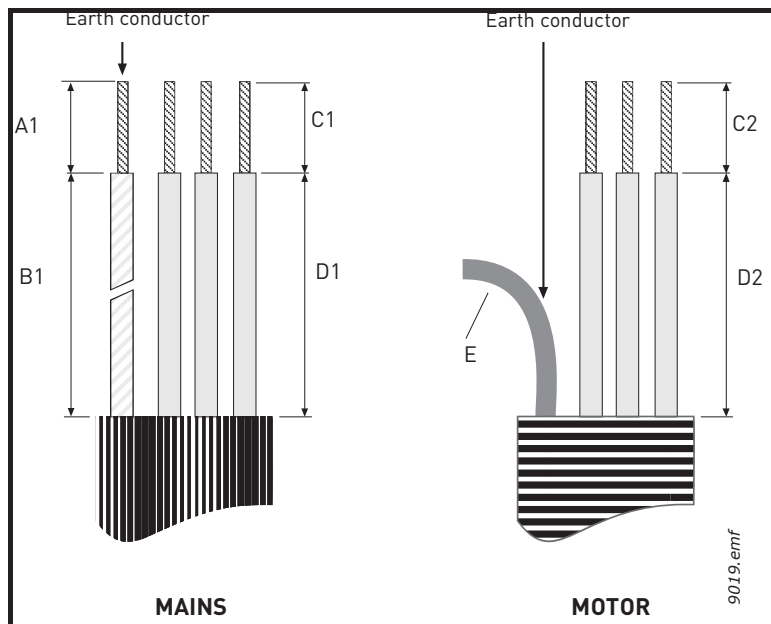

Figure 17. Stripping of cables

Frame	A1	B1	C1	D1	C2	D2	E
MR4	.59	1.38	.39	.79	.28	1.38	Leave as short as possible
MR5	.79	1.57	.39	1.18	.39	1.57	
MR6	.79	3.54	.59	2.36	.59	2.36	
MR7	.79	3.15	.79	3.15	.79	3.15	

Table 10. Cables stripping lengths [in]

**2**

Open the cover of the drive.

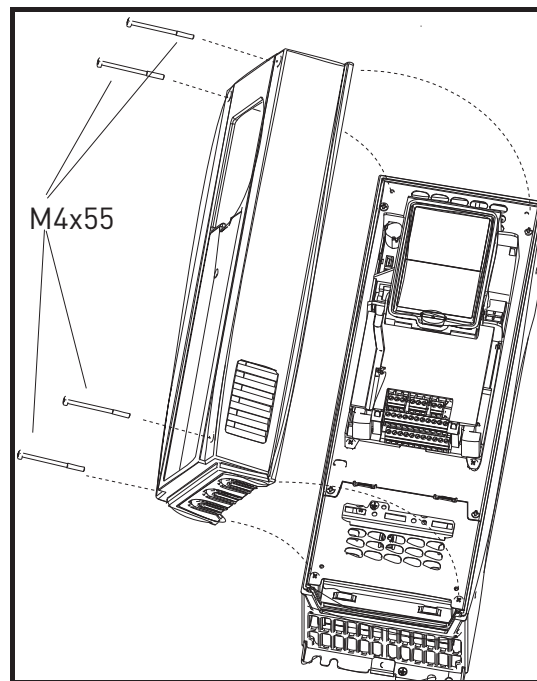

Figure 18.

**3**

Remove the screws of the cable protection plate. Do not open the cover of the power unit!

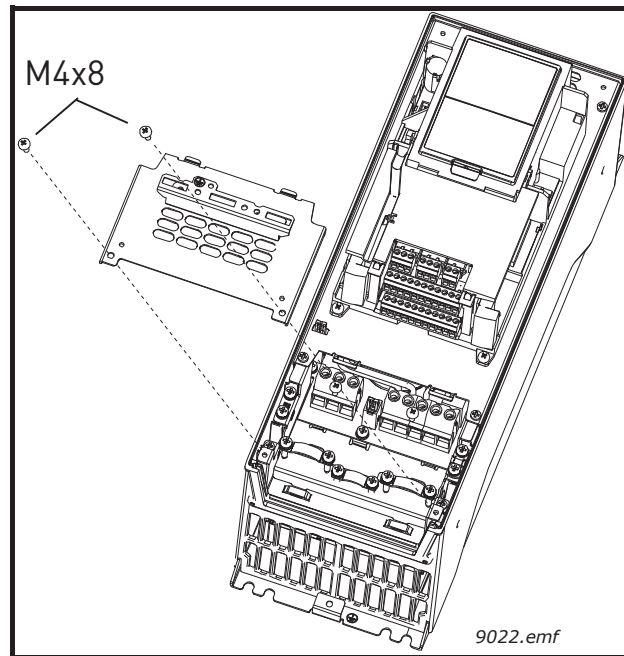

Figure 19.

**4**

Insert the cable grommets (included in the delivery) in the openings of the cable entry plate (included) as shown in the picture.

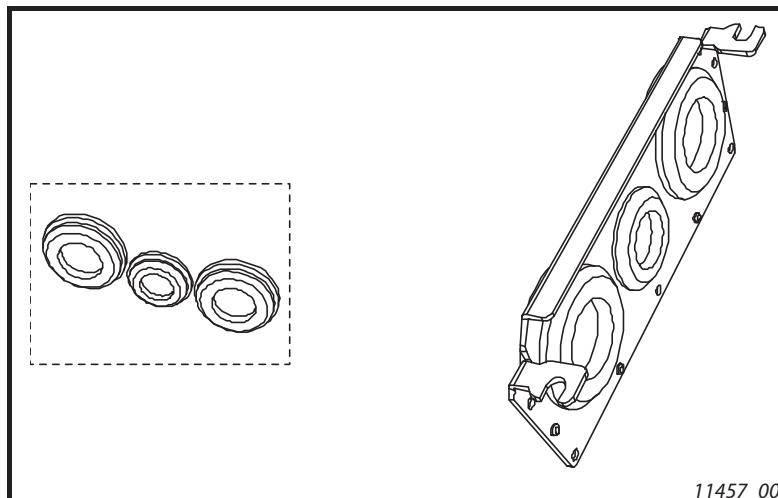

Figure 20.

**5**

Insert the cables - supply cable, motor cable - in the openings of the cable entry plate. Then cut the rubber grommets open to slide the cables through. Do not cut the grommet openings wider than what is necessary for the cables you are using.

**IMPORTANT NOTE FOR NEMA12 INSTALLATION:**

To meet the requirements of the enclosure class NEMA12, the connection between the grommet and the cable must be tight. Therefore, lead the first bit of the cable out of the grommet straight before letting it bend. If this is not possible, the tightness of the connection must be ensured with insulation tape or a cable tie.

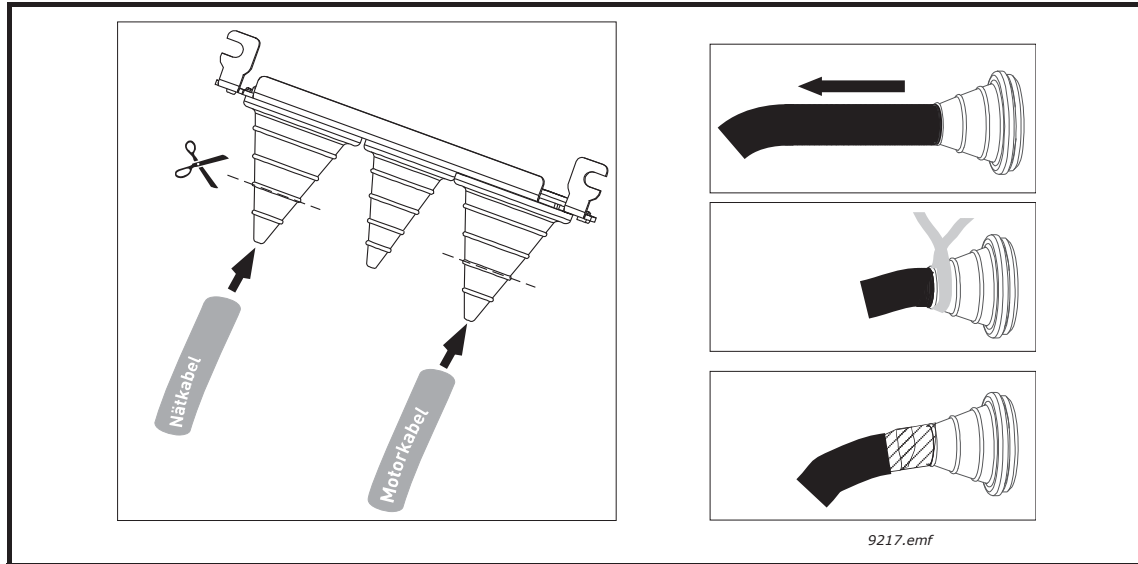

Figure 21.

**6**

Detach the cable clamps and the grounding clamps (Figure 22) and place the cable entry plate with the cables in the groove on the drive frame (Figure 23).

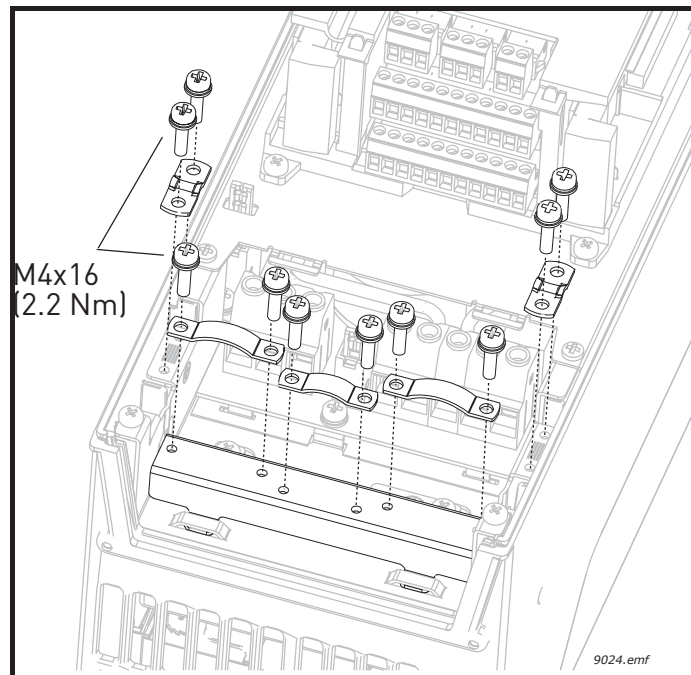

Figure 22.

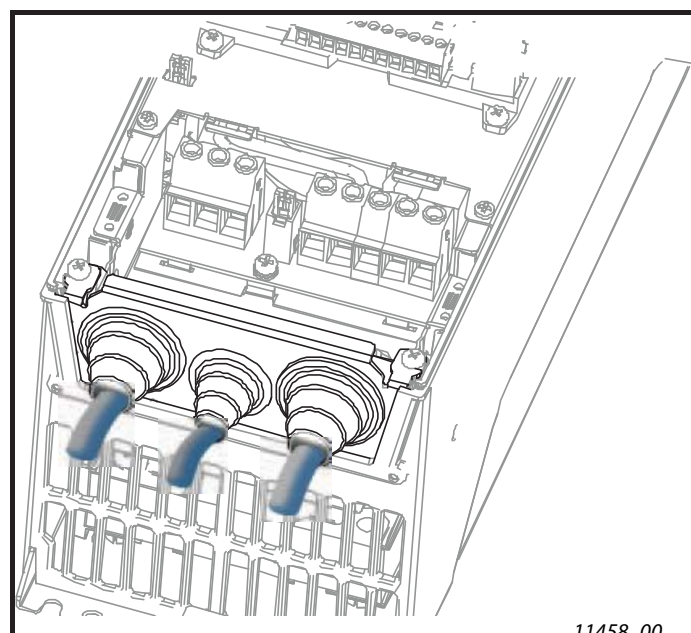

Figure 23.

7	<p>Connect the stripped cables (see Figure 17 and Table 10) as shown in Figure 24.</p> <ul style="list-style-type: none"> <li>• Expose the shield of all three cables in order to make a 360-degree connection with the cable clamp (1).</li> <li>• Connect the (phase) conductors of the supply and motor cables into their respective terminals (2).</li> <li>• Form the rest of the cable shield of all three cables into “pigtails” and make a grounding connection with a clamp as shown in Figure 24 (3). Make the pigtails <b>just long enough</b> to reach and be fixed to the terminal - not longer.</li> </ul>
---	--

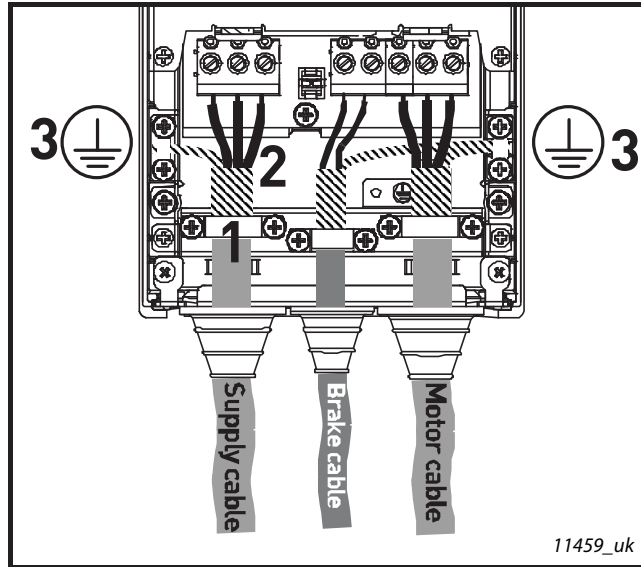



Figure 24.

**Tightening torques of cable terminals:**

Frame	Type	Tightening torque [Nm]/[lb-in.] Power and motor terminals		Tightening torque [Nm]/[lb-in.] EMC grounding clamps		Tightening torque, [Nm]/[lb-in.] Grounding terminals	
		[Nm]	lb-in.	[Nm]	lb-in.	[Nm]	lb-in.
MR4	A 0007-A 0040	0.5—0.6	4.5—5.3	1.5	13.3	2.0	17.7
	C 0015-C 0075						
MR5	A 0050-A 0100	1.2—1.5	10.6—13.3	1.5	13.3	2.0	17.7
	C 0100-C 0200						
	D 0030-D 0100						
MR6	A 0150-A 0200	10	88.5	1.5	13.3	2.0	17.7
	C 0250-C 0400						
	D 0150-D 0300						
MR7	A 0250-A 0400	8/15*	70.8/132.8*	1.5	13.3	8/15*	70.8/132.8*
	C 0500-C 0750						
	D 0400-D 0600						

\*. Cable clamping (Ouneva Pressure Terminal Connector)

Table 11. Tightening torques of terminals

**8** Check the connection of the grounding cable to the motor and the drive terminals marked with  .

**NOTE:** Two protective conductors are required according to standard EN61800-5-1. See Figure 25 and chapter Grounding and ground fault protection. Use an M5 size screw and tighten it to 2.0 Nm (17.7 lb-in.).

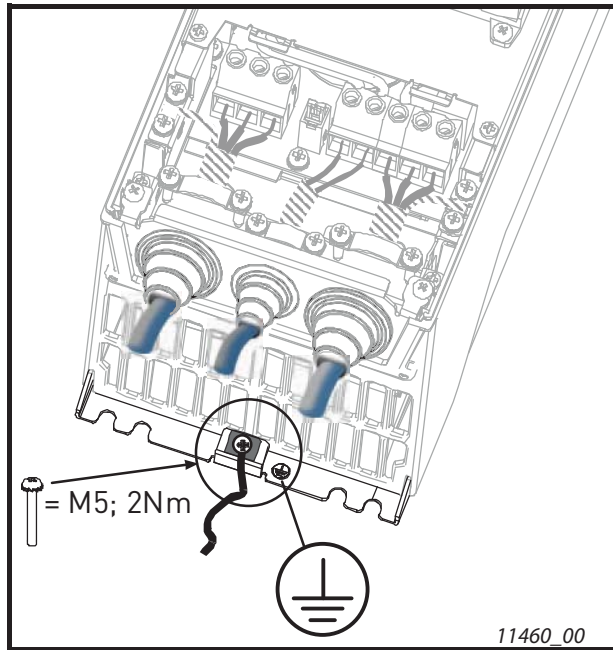

Figure 25. Additional protective grounding connector

**9** Re-mount the cable protection plate (Figure 26) and the cover of the drive.

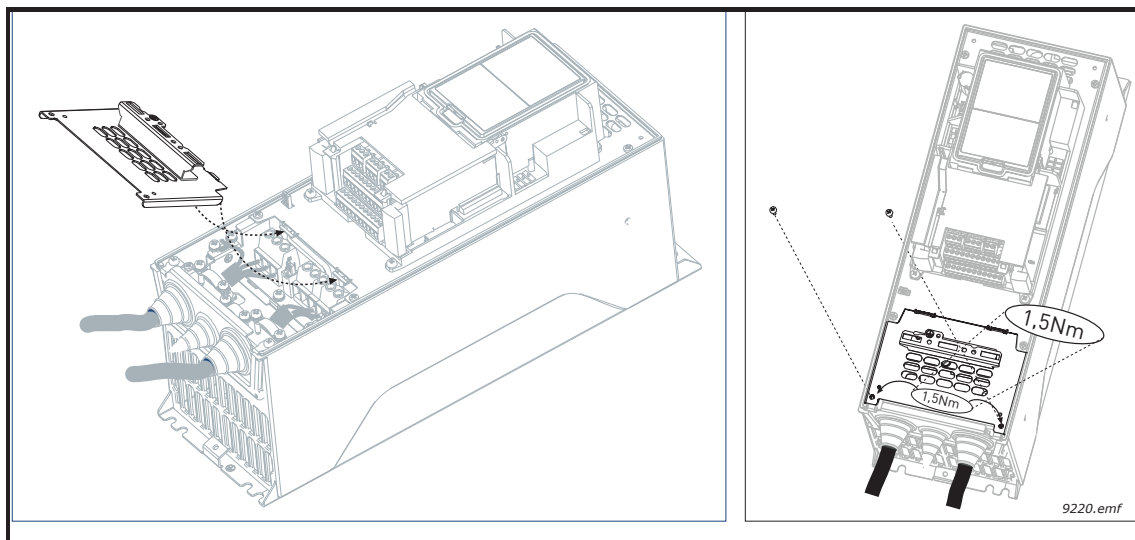

Figure 26. Re-mounting of cover components

4.3.2 Frames MR8 and MR9

**1** Strip the motor and mains cables as advised below.

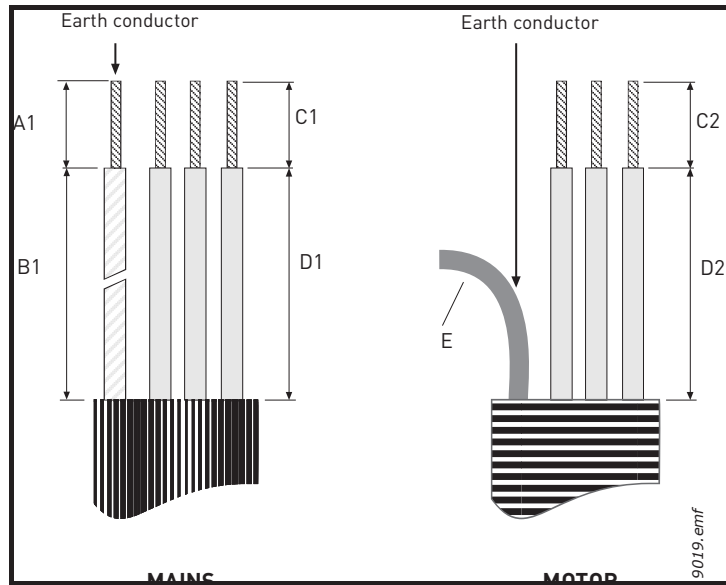

Figure 27. Stripping of cables

Frame	A1	B1	C1	D1	C2	D2	E
MR8	1.57	7.09	.98	11.81	.98	11.81	Leave as short as possible
MR9	1.57	7.09	.98	11.81	.98	11.81	

Table 12. Cables stripping lengths [in]



**2** MR9 only: Remove the main cover of the AC drive.

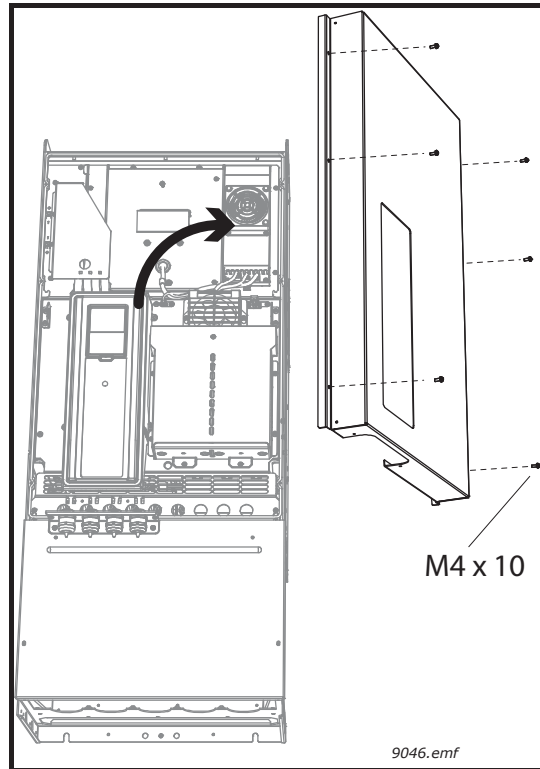

Figure 28.

**3** Remove the cable cover (1) and the cable fitting plate (2).

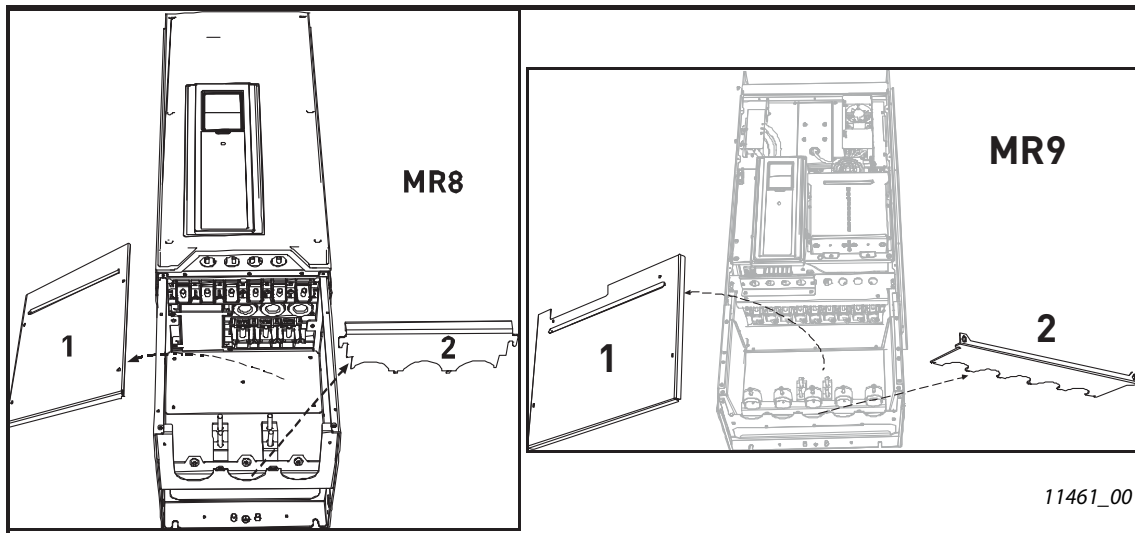

Figure 29.

**4** MR9 only: Loosen the screws and remove the sealing plate.

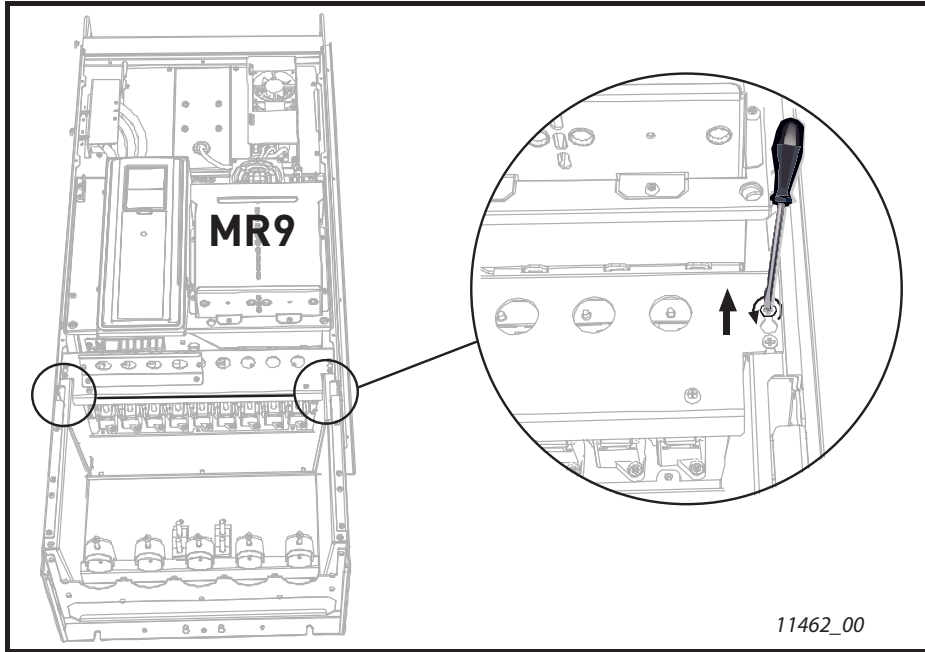

Figure 30.

**5** Locate the terminals. **OBSERVE** the exceptional placement of motor cable terminals in MR8!

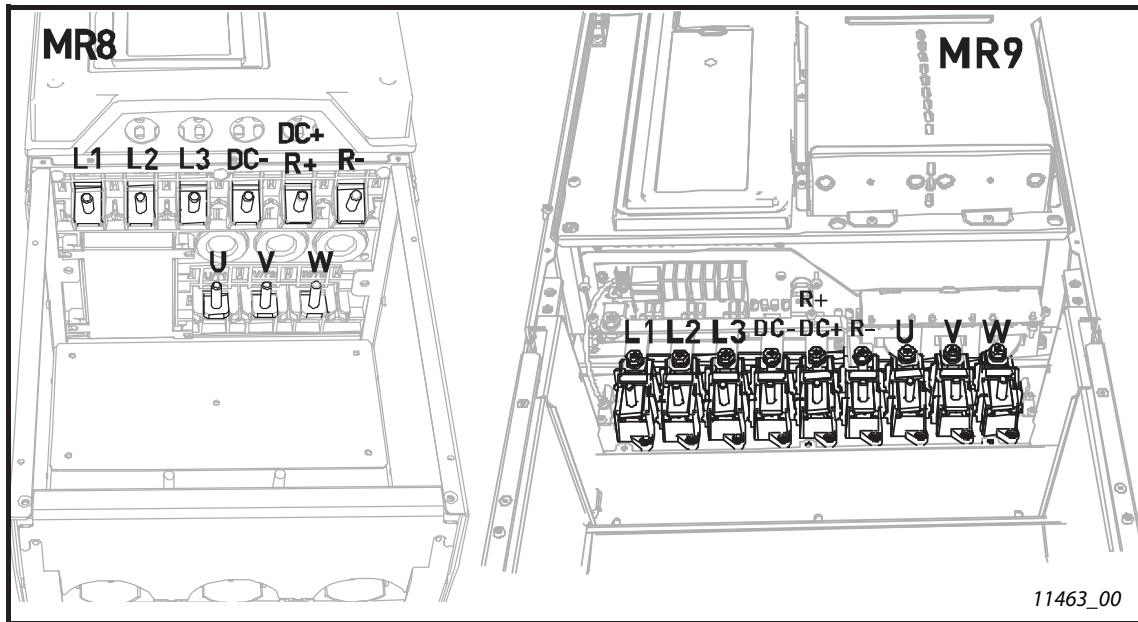
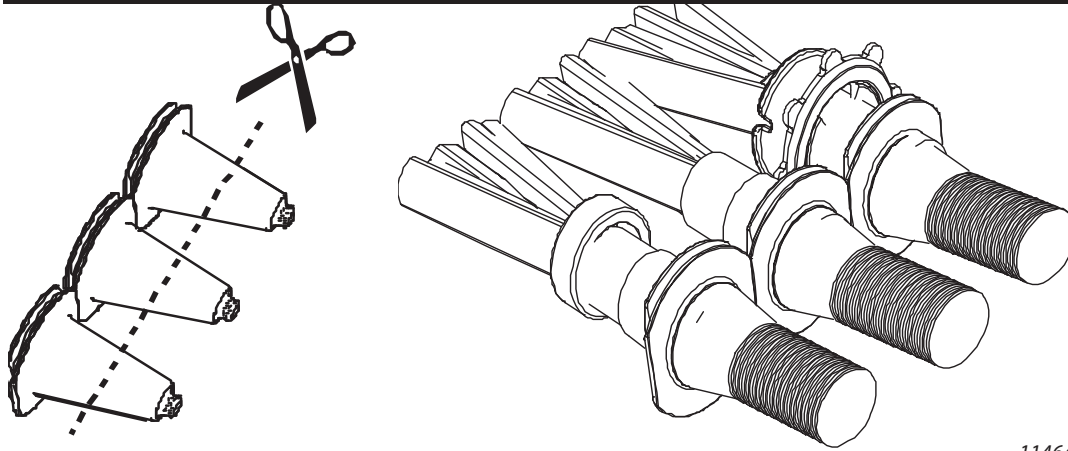

Figure 31.

6

Cut the rubber grommets open to slide the cables through. Should the grommets fold in while inserting the cable, just draw the cable back a bit to straighten the grommets up. Do not cut the grommet openings wider than what is necessary for the cables you are using.



11464 00

Figure 32.

7

Place the grommet with the cable so that the frame end plate fits in the groove on the grommet, see Figure 33. To meet the requirements of the enclosure class NEMA12, the connection between the grommet and the cable must be tight. Therefore, lead the first bit of the cable out of the grommet **straight** before letting it bend. If this is not possible, the tightness of the connection must be ensured with insulation tape or a cable tie. As an example, see Figure 21.

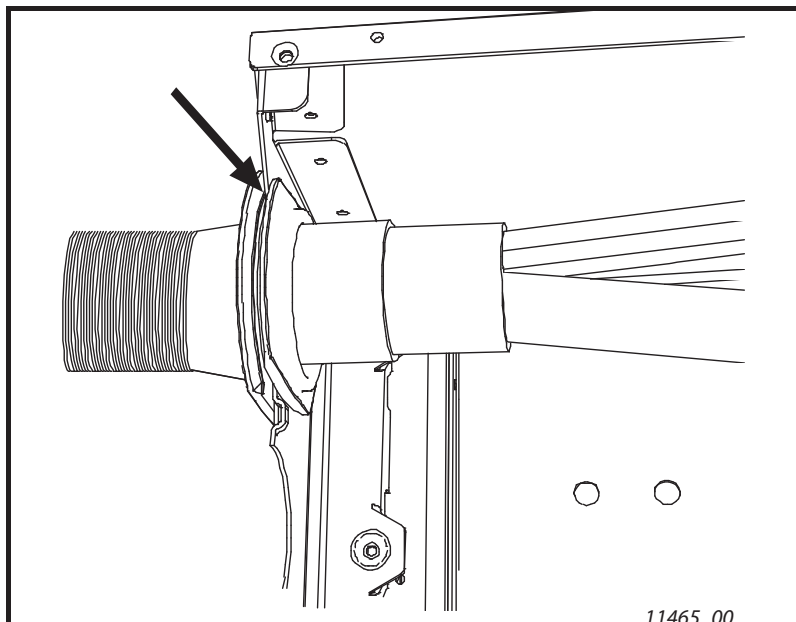

11465 00

Figure 33.

**8**

If you use thick cables insert the cable separators in between the terminals in order to avoid contact between the cables.

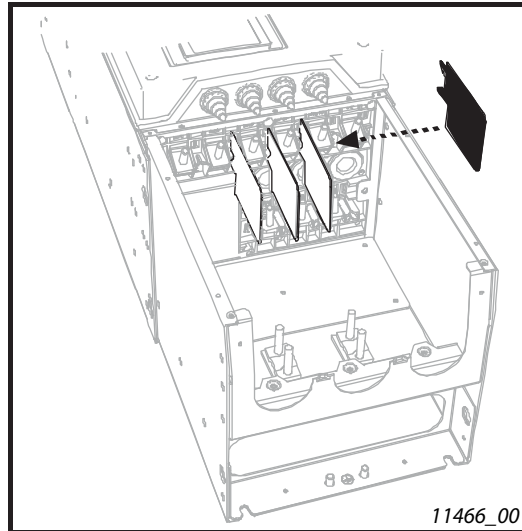

Figure 34.

**9**

Connect the cables stripped as shown in Figure 27.

- Connect the (phase) conductors of the supply and motor cables into their respective terminals (a).
- Form the rest of the cable shield of all cables into “pigtails” and make a grounding connection as shown in Figure 35 (b) using the clamp from the *Accessories bag*.
- Note also correct position of the ferrite holder (c) AFTER the cable stripping (in MR8 and EMC class C2 only).
- Note: If you use several cables on one connector observe the position of cable lugs on top of each other. See Figure 36 below.

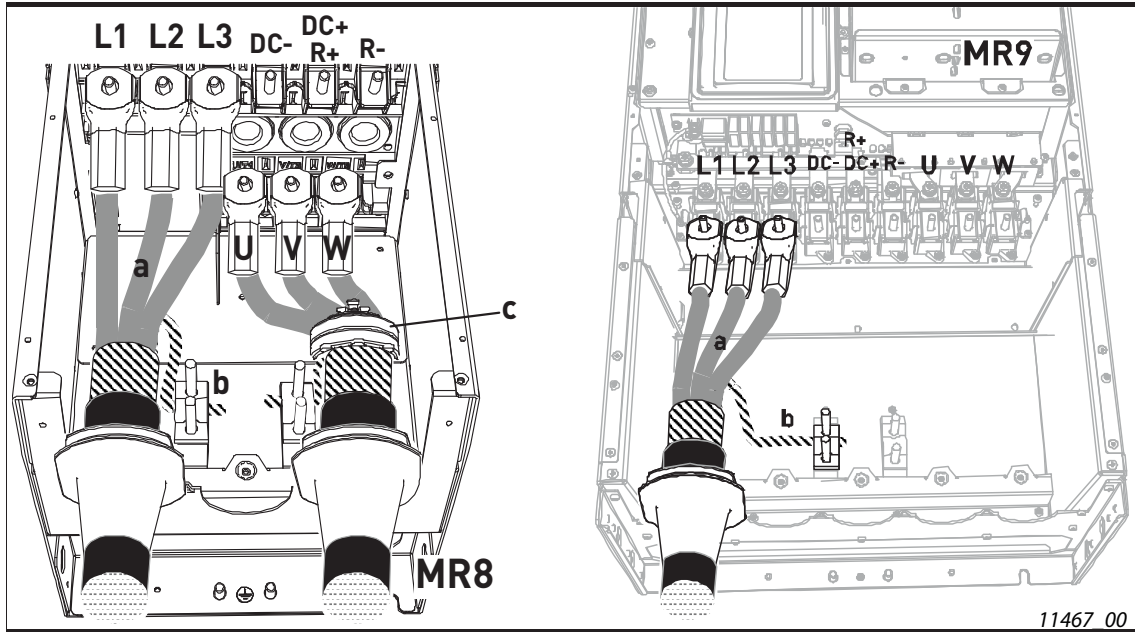

Figure 35.

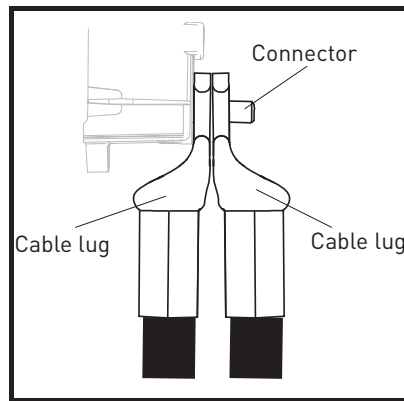

Figure 36. Placing two cable lugs on top of each other

**Tightening torques of cable terminals:**

Frame	Type	Tightening torque [Nm]/[lb-in.] Power and motor terminals		Tightening torque [Nm]/[lb-in.] EMC grounding clamps		Tightening torque, [Nm]/[lb-in.] Grounding terminals	
		[Nm]	lb-in.	[Nm]	lb-in.	[Nm]	lb-in.
MR8	A 0500-A 0750	20/40*	177/354*	1.5	13.3	20	177
	C 1000-C 1500						
	D 0750-D 1250						
MR9	A 1000-A 1250	20/40*	177/354*	1.5	13.3	20	177
	C 2000-C 2500						
	D 1500-D 2000						

\*. Cable clamping (Ouneva Pressure Terminal Connector)

Table 13. Tightening torques of terminals

**10** Expose the shield of all three cables in order to make a 360-degree connection with the cable clamp.

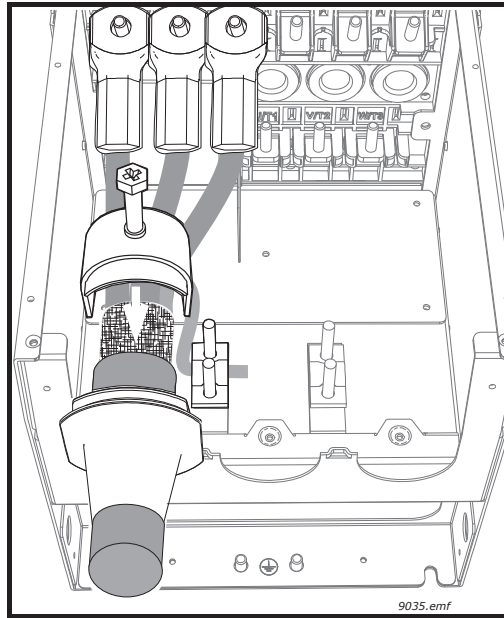

Figure 37.

**11** Re-attach first the cable fitting plate and then the cable cover.

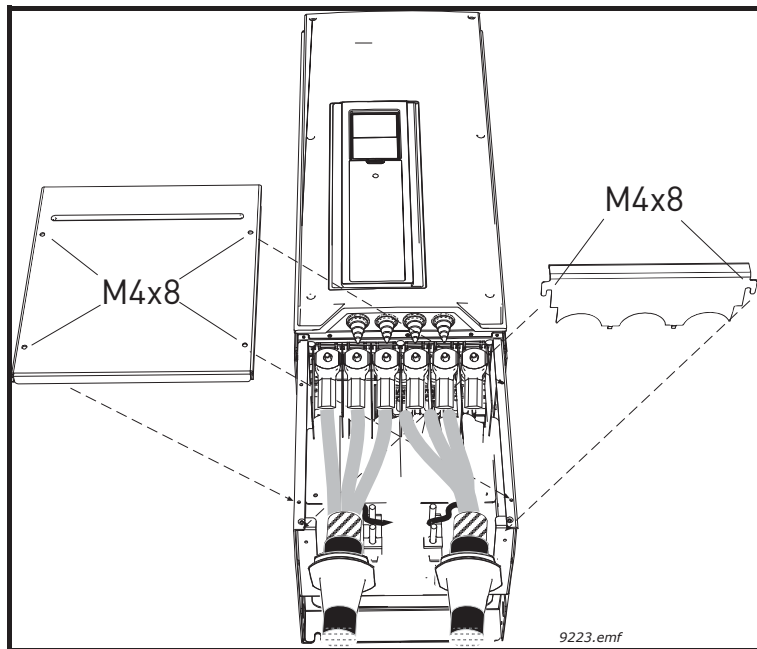

Figure 38.

**12**

**MR9 only:** Now re-mount the main cover (unless you want to make the control connections first).

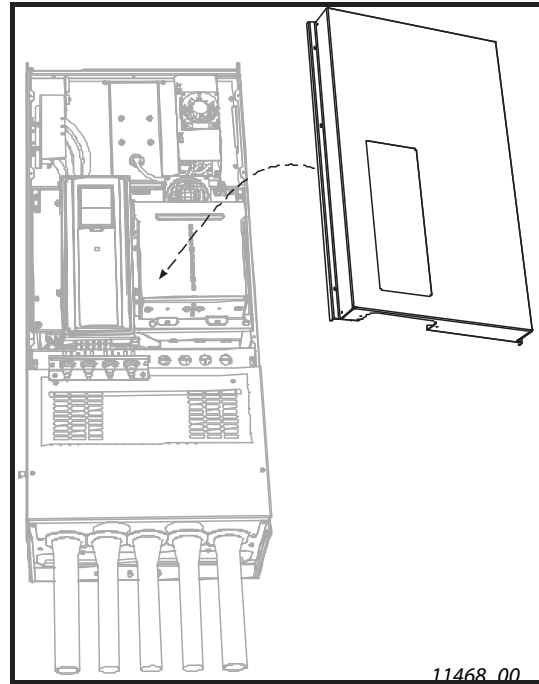



Figure 39.

**13**

Check the connection of the earth cable to the motor and the AC drive terminals marked with .

**NOTE:** Two protective conductors are required according to standard EN61800-5-1. See chapter Grounding and ground fault protection.

Connect the protective conductor using a cable shoe and an M8 screw (included in the *Accessories bag*) on **either** of the screw connectors as advised in Figure 40.

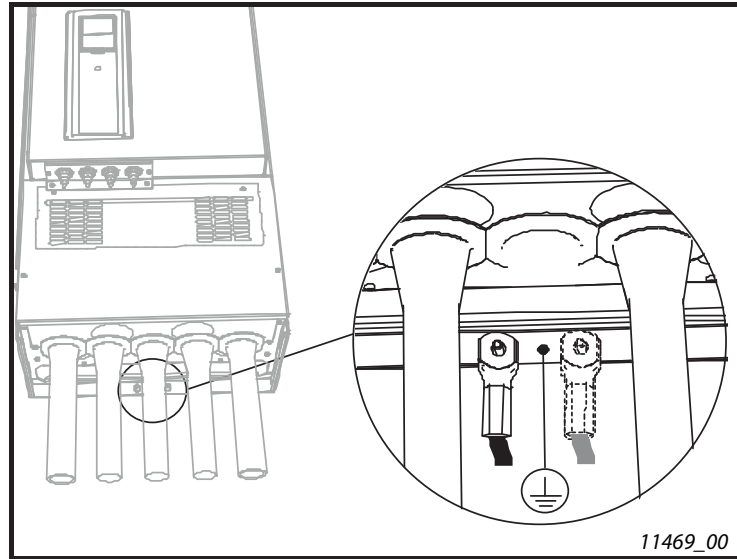

Figure 40.

#### 4.3.3 Cable and motor insulation checks

1. Motor cable insulation checks  
Disconnect the motor cable from terminals U, V and W of the drive and from the motor. Measure the insulation resistance of the motor cable between each phase conductor as well as between each phase conductor and the protective ground conductor. The insulation resistance must be  $>1\text{M}\Omega$  at ambient temperature of  $68^\circ\text{F}$ .
2. Mains cable insulation checks  
Disconnect the mains cable from terminals L1, L2 and L3 of the drive and from the mains. Measure the insulation resistance of the mains cable between each phase conductor as well as between each phase conductor and the protective ground conductor. The insulation resistance must be  $>1\text{M}\Omega$  at ambient temperature of  $68^\circ\text{F}$ .
3. Motor insulation checks  
Disconnect the motor cable from the motor and open the bridging connections in the motor connection box. Measure the insulation resistance of each motor winding. The measurement voltage must equal at least the motor nominal voltage but not exceed 1000 V. The insulation resistance must be  $>1\text{M}\Omega$  at ambient temperature of  $68^\circ\text{F}$ .

#### 4.4 Installation in corner-grounded network

Corner grounding is allowed for the drive types rating from 72 A to 310 A at 380...480 V supply and from 75 A to 310 A at 208...240 V supply.

In these circumstances the EMC protection class must be changed to level C4 following the instructions in Chapter 5.2 of this manual.

Corner grounding is not allowed for the drive types with rating from 3.4 A to 61 A at 380...480 V supply and 3.7 A to 62 A with 208...240 V supply.



## 5. COMMISSIONING

*Before commissioning, note the following directions and warnings:*



Internal components and circuit boards of the drive (except for the galvanically isolated I/O terminals) are live when it is connected to mains potential. **Coming into contact with this voltage is extremely dangerous and may cause death or severe injury.**



The motor terminals **U, V, W** and the brake resistor terminals **B-/B+** are live when the drive is connected to mains, **even if the motor is not running.**



The control I/O-terminals are isolated from the mains potential. However, the **relay outputs and other I/O-terminals may have a dangerous control voltage** present even when the drive is disconnected from mains.



Do not make any connections to or from the drive when it is connected to the mains.



**After disconnecting** the drive from the mains, **wait** until the fan stops and the indicators on the keypad go out (if no keypad is attached see the indicators on the cover). Wait 5 more minutes before doing any work on the connections of the drive. Do not open the cover before this time has expired. After expiration of this time, use a measuring equipment to absolutely ensure that no voltage is present. **Always ensure absence of voltage before electrical work!**



**Before connecting** the frequency converter to mains make sure that the front and cable covers of the drive are closed.

## 5.1 Commissioning of the SmartVFD HVAC

<b>1</b>	Read carefully the safety instructions in Chapter 1 and above and follow them.
<b>2</b>	<p>After the installation, make sure that:</p> <ul style="list-style-type: none"> <li>• both the drive and the motor are grounded.</li> <li>• the mains and motor cables comply with the requirements given in chapter 4.1.1.</li> <li>• the control cables are located as far as possible from the power cables, see chapter 4.3.</li> <li>• the shields of the shielded cables are connected to protective ground marked with .</li> <li>• check the tightening torques of all terminals</li> <li>• the wires do not touch the electrical components of the drive.</li> <li>• the common inputs of digital input groups are connected to +24V or ground of the I/O terminal or the external supply.</li> </ul>
<b>3</b>	Check the quality and quantity of cooling air (chapter 3.2 and Table 6).
<b>4</b>	Check the inside of the drive for condensation.
<b>5</b>	<b>Check that all Start/Stop switches connected to the I/O terminals are in Stop-position.</b>
<b>6</b>	<p>Before connecting the AC drive to mains:</p> <ul style="list-style-type: none"> <li>• check mounting and condition of all fuses and other protective devices</li> </ul>
<b>7</b>	Run the Startup Wizard (see the Application Manual).

## 5.2 Changing EMC protection class

If your supply network is an IT (impedance-grounded) system but your AC drive is EMC-protected according to class C2 you need to modify the EMC protection of the AC drive to EMC-level T. This is done by removing the built-in EMC jumpers with a simple procedure described below:



Warning! Do not perform any modifications on the drive when it is connected to mains.

### 5.2.1 Frames MR4 to MR6

1

Remove the main cover of the drive (see pages 24 and 31) and locate the jumpers connecting the built-in RFI-filters to ground. See Figure 41. and Figure 42.

**NOTE:** The locations of the EMC-jumpers have changed in frames MR5 and MR6. Figure 41. shows the old locations and Figure 42. the new locations in frames MR5 and MR6.

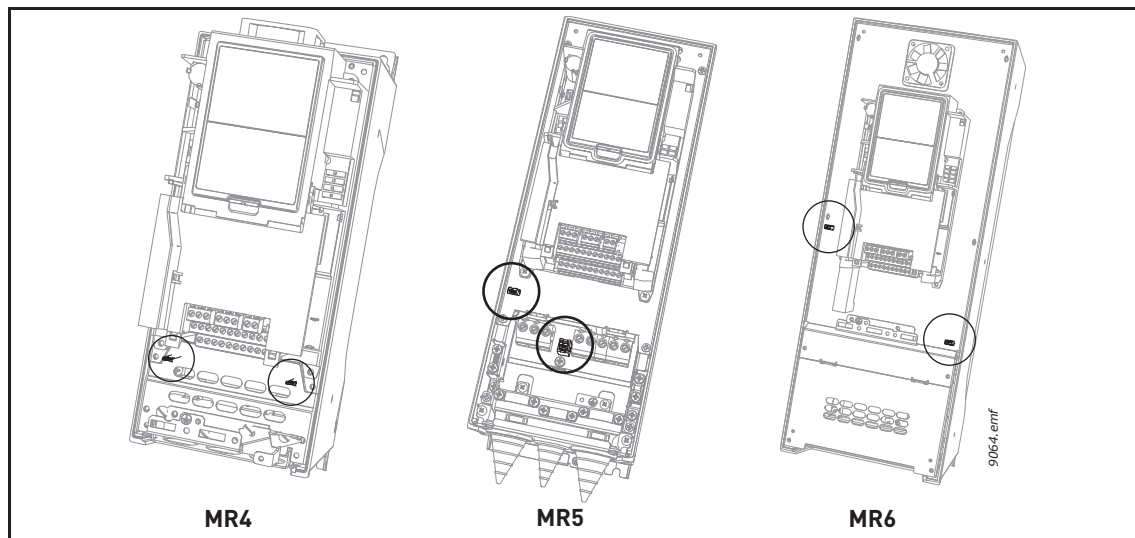

Figure 41. Current locations of the EMC-jumpers in frame MR4, old locations in frames MR5 and MR6

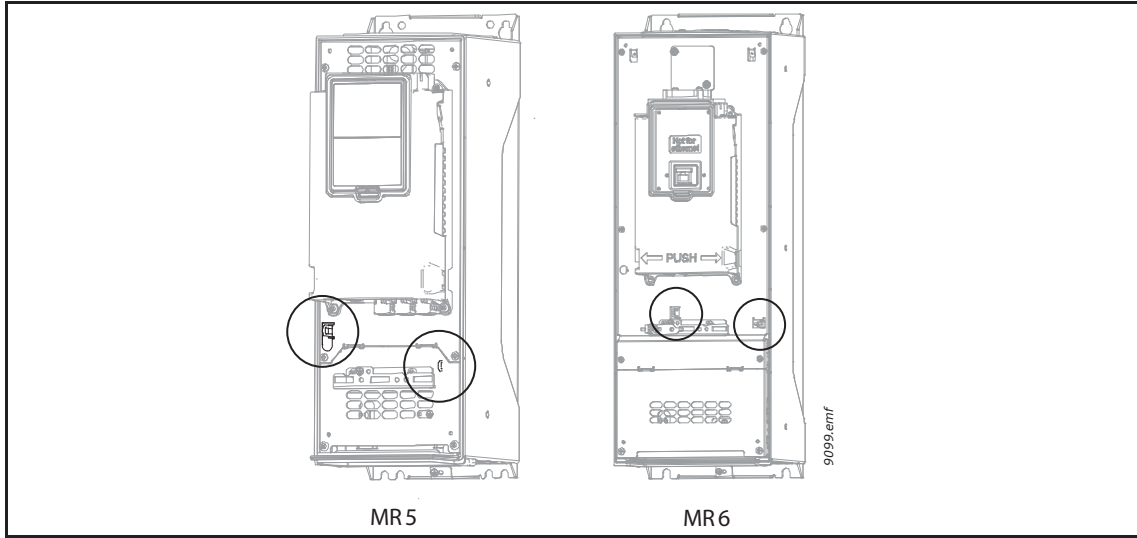

Figure 42. Current locations of the EMC-jumpers in frames MR5 and MR6

**2** Disconnect the RFI-filters from ground by removing the EMC-jumpers using long-nose pliers or similar. See Figure 43.

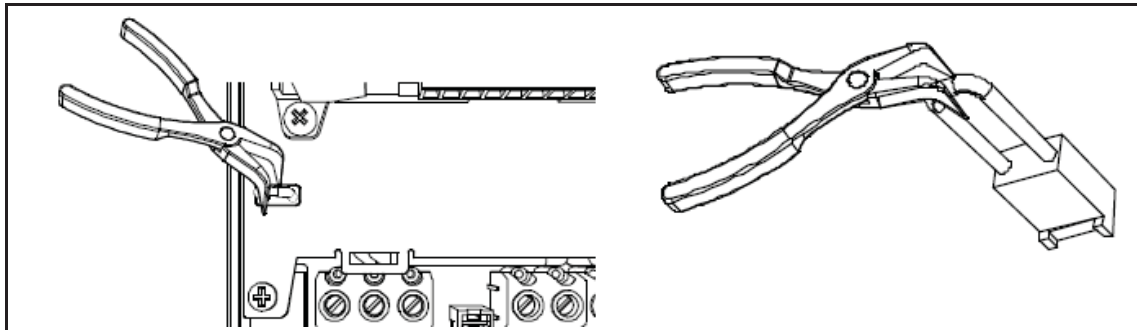

Figure 43. Removing the jumper, MR5 as example

### 5.2.2 Frames MR7 and MR8

Follow the procedure described above to modify the EMC protection of the drive of frames MR7 and MR8 to EMC-level C4.

**1**

Remove the main cover of the drive and locate the jumper. **MR8 only:** Push down the grounding arm. See Figure 44.

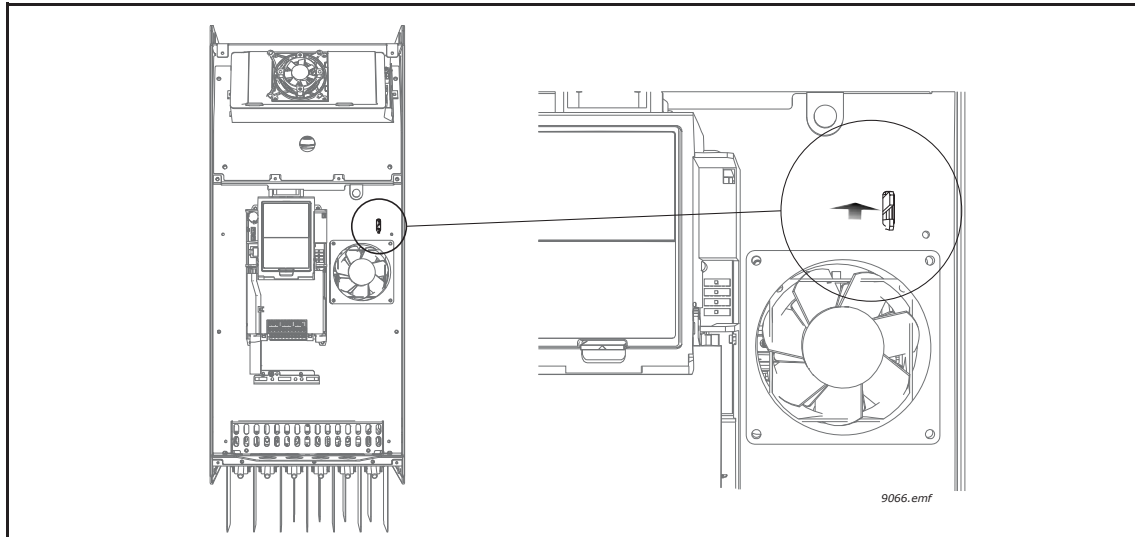

Figure 44.

**2**

**MR7 and MR8:** Locate the EMC box under the cover. Remove the screws of the box cover to expose the EMC-jumper. Detach the jumper and re-fix the box cover.

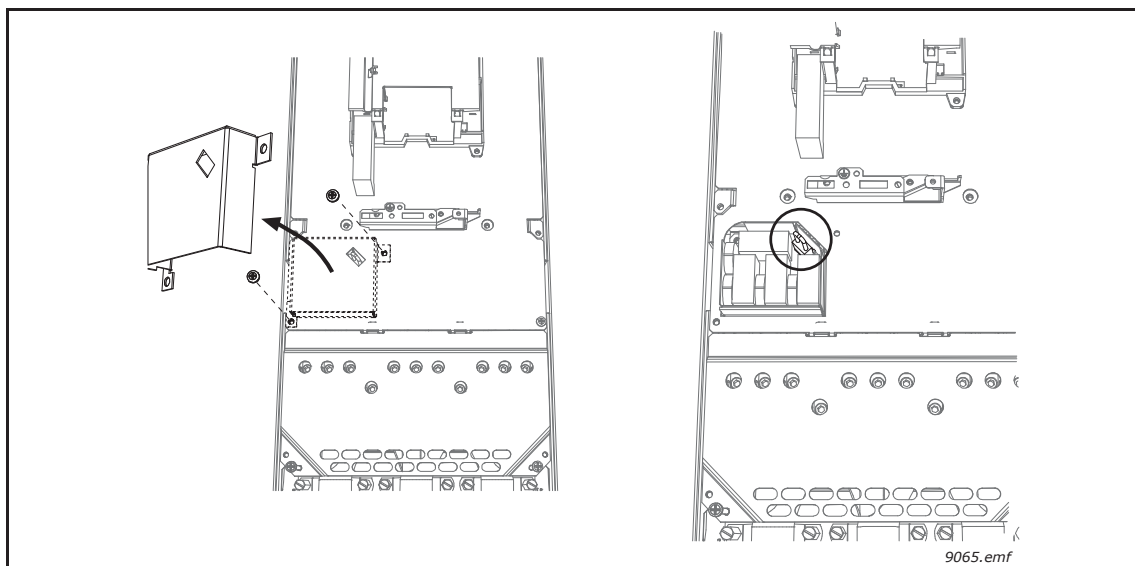

Figure 45.

**3****MR7 only:** locate the DC grounding busbar between connectors R- and U and detach the busbar from the frame by undoing the M4 screw.

Figure 46. MR7: Detaching the DC grounding busbar from frame

### 5.2.3 Frame MR9

Follow the procedure described above to modify the EMC protection of the AC drive of frame MR9 to EMC-level T.

**1** Find the *Molex* connector in the accessories bag. Remove the main cover of the AC drive and locate the place for the connector next to the fan. Push the Molex connector in its place. See Figure 47.

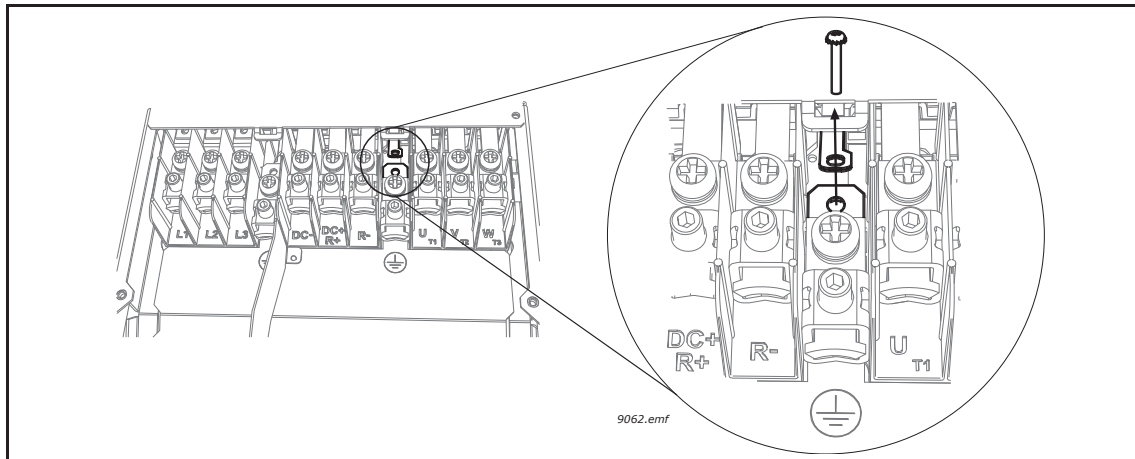
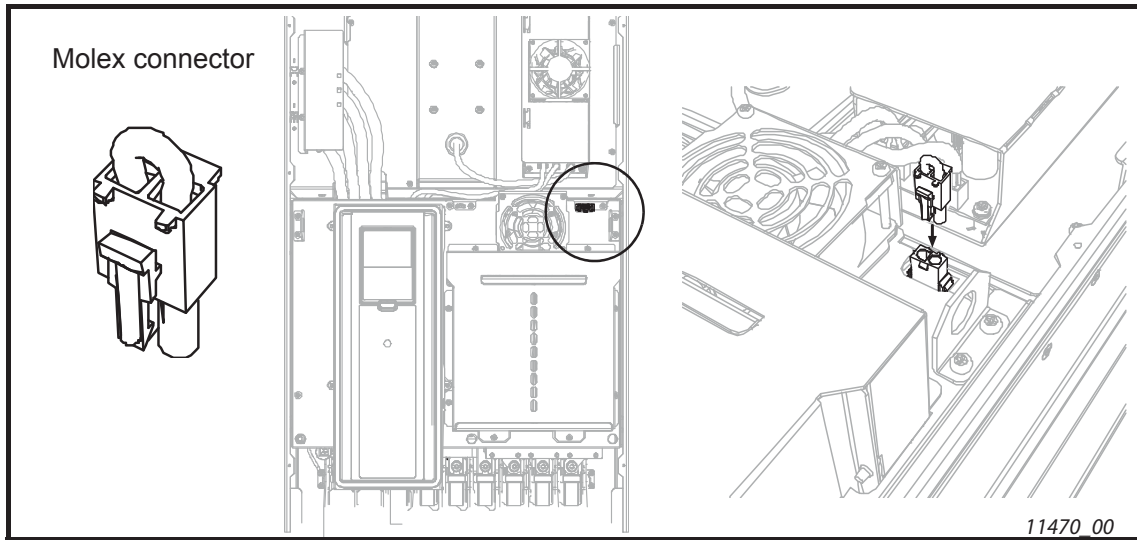

Figure 47.

**2** Further remove the extension box cover (1), the touch shield (2) the I/O plate (4) with I/O grommet plate (3). Locate the EMC jumper on the EMC board (see magnification below) and remove it.

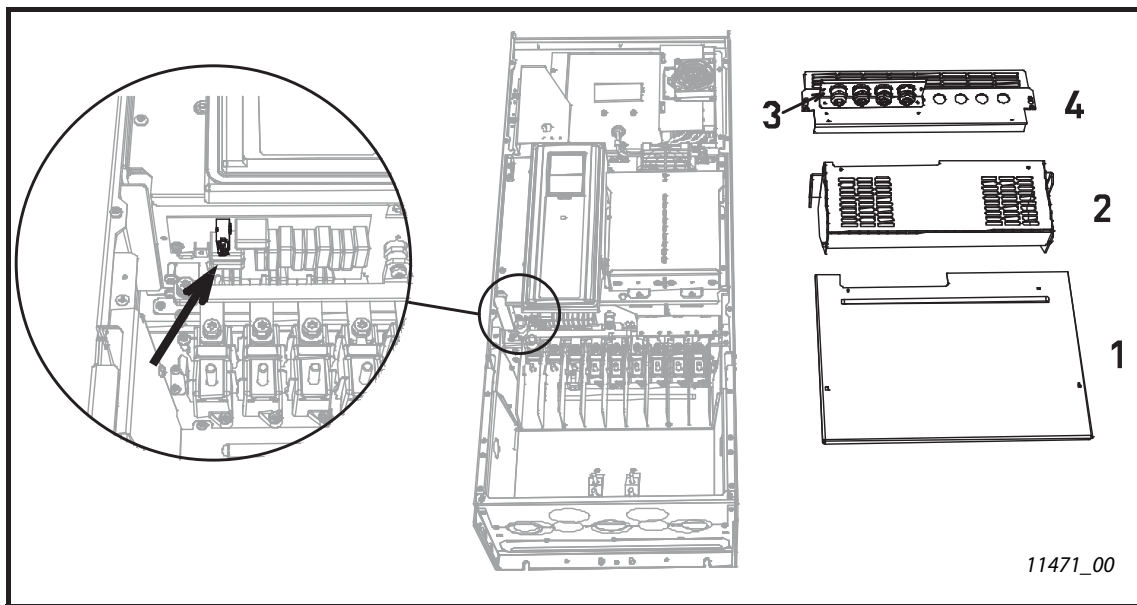

Figure 48.

	<b>CAUTION!</b> Before connecting the AC drive to mains make sure that the EMC protection class settings of the drive are appropriately made.
	<b>NOTE!</b> After having performed the change write ' <i>EMC level modified</i> ' on the sticker included with the drive delivery (see below) and note the date. Unless already done, attach the sticker close to the name plate of the drive. <div data-bbox="626 407 1138 533" style="border: 1px solid black; border-radius: 10px; padding: 5px; text-align: center;"><p><b>Product modified</b></p><p>Date: _____</p><p>Date: _____</p><p>EMC-level modified C1 -&gt;T Date: DD.MM.YY</p></div>



## 6. CONTROL UNIT

The control unit of the AC drive contains the standard boards and the option boards. The option boards are connected to the slots of the control board (see 6.3 Installation of Option Boards).

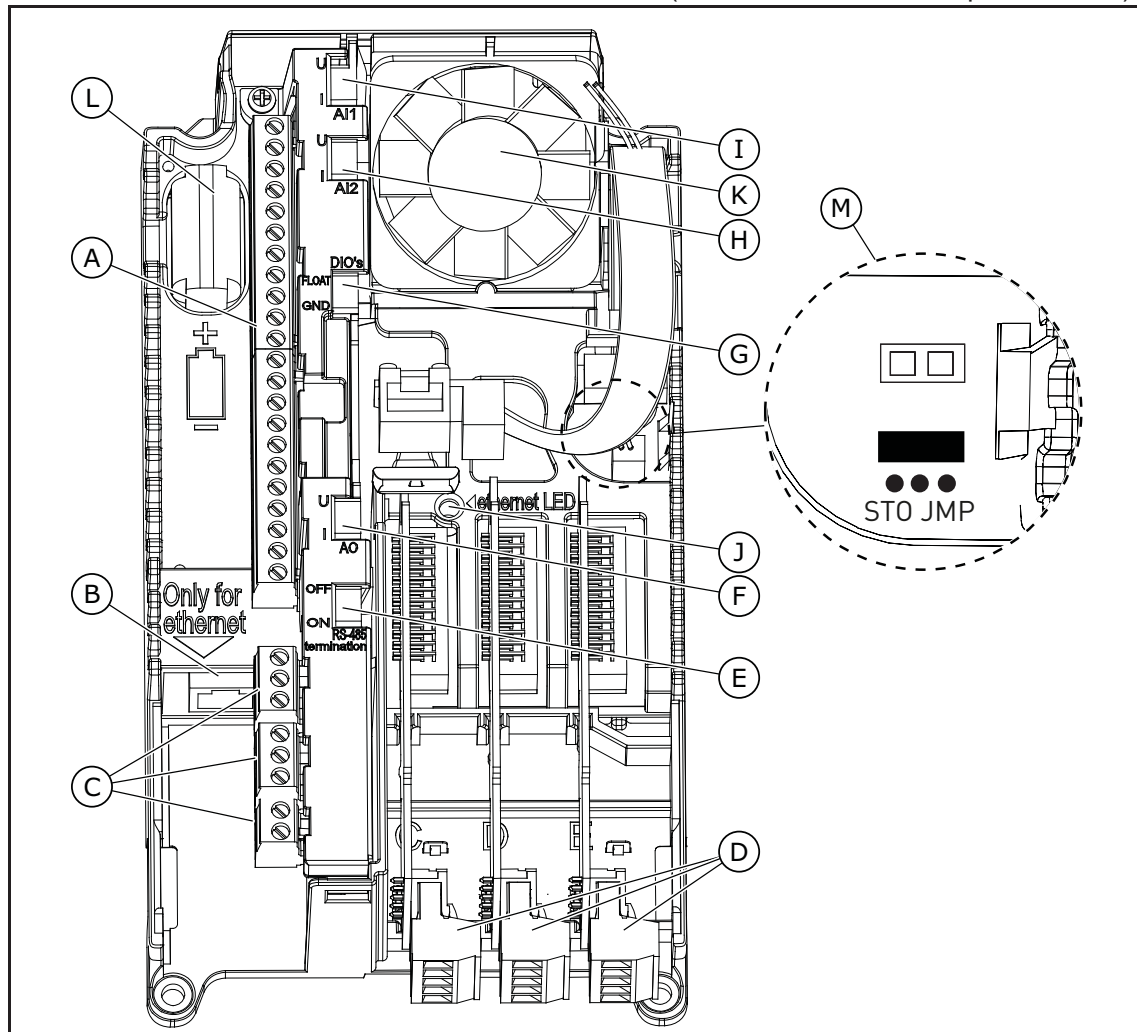

Figure 49. The components of the control unit

- |  |  |
|--|--|
| A. The control terminals for the standard I/O connections  | B. The Ethernet connection                                   |
| C. The relay board terminals for 3 relay outputs or 2 relay outputs and a thermistor                               | D. The option boards   |
| E. A DIP switch for the RS485 bus termination  | F. A DIP switch for the signal selection of Analogue Output  |
| G. A DIP switch for the isolation of the digital inputs from ground  | H. A DIP switch for the signal selection of Analogue Input 2 |
| I. A DIP switch for the signal selection of Analogue Input 1   | J. The status indicator of the Ethernet connection           |
| K. A fan (only in IP54 of MR4 and of MR5)  | L. The battery for the RTC                                   |
| M. The location and the default position of the Safe Torque Off (STO) jumper (feature not available, do not touch) |  |

When you receive the AC drive, the control unit contains the standard control interface. If you included special options in your order, the AC drive will be as in your order. On the next pages, you will find information on the terminals and general wiring examples.

It is possible to use the drive with an external power source with these properties: +24 VDC  $\pm 10\%$ , minimum 1000 mA. Connect the external power source to terminal 30. This voltage is sufficient to keep the control unit on and for you to set the parameters. The measurements of the main circuit (for example, the DC link voltage, and the unit temperature) are not available when the drive is not connected to mains.

The status LED of the drive shows the status of the drive. The status LED is located in the control panel, below the keypad, and it can show 5 different statuses.

Colour of the LED light	Status of the drive
Blinking slowly	Ready
Green	Run
Red	Fault
Orange	Alarm
Blinking fast	Downloading software

Table 14. The statuses of the status LED of the drive

## 6.1 Control Unit Cabling

The standard I/O board has 22 fixed control terminals and 8 relay board terminals. You can see the standard connections of the control unit and the descriptions of signals in Fig. 39.

### 6.1.1 Selection of the Control Cables

The control cables must be a minimum of 20 AWG (0.5 mm<sup>2</sup>) screened multicore cables. See more on the cable types in Table 7 on page 19. The terminal wires must be a maximum of 12 AWG (2.5 mm<sup>2</sup>) for the relay board terminals and other terminals.

The terminal	The terminal screw	Tightening torque	
		Nm	lb-in.
All the terminals of the I/O board and the relay board	M3	0.5	4.5

Table 15. Control cable tightening torques

### 6.1.2 Control Terminals and Dip Switches

Here you see the basic description of the terminals of the standard I/O board and the relay board. For more information, see 8.2.1 Technical information on control connections.

Some terminals are assigned for signals that have optional functions that you can use with the DIP switches. See more in 6.1.2.1 Selection of terminal functions with DIP switches.

		Standard I/O board																		
		Terminal	Signal	Description																
Reference potentiometer 1...10kΩ	↑	1	+10 Vref	Reference output																
		2	AI1+	Analogue input, voltage or current	Frequency reference															
2-wire transmitter	↔	3	AI1-	Analogue input common, (current)																
		4	AI2+	Analogue input, voltage or current	Frequency reference															
Actual value I = (0)4...20mA	↔	5	AI2-	Analogue input common, (current)																
		6	24Vout	24V auxiliary voltage																
-	-	7	GND	I/O ground																
		8	DI1	Digital input 1	Start forward															
		9	DI2	Digital input 2	Start reverse															
		10	DI3	Digital input 3	External fault															
		11	CM	Common for DI1-DI6	*)															
		12	24Vout	24V auxiliary voltage																
-	-	13	GND	I/O ground																
		14	DI4	Digital input 4	<table border="1"> <tr> <td>DI4</td> <td>DI5</td> <td>Freq. ref.</td> </tr> <tr> <td>Open</td> <td>Open</td> <td>Analog input 1</td> </tr> <tr> <td>Closed</td> <td>Open</td> <td>Preset Freq. 1</td> </tr> <tr> <td>Open</td> <td>Closed</td> <td>Preset Freq. 2</td> </tr> <tr> <td>Closed</td> <td>Closed</td> <td>Preset Freq. 3</td> </tr> </table>	DI4	DI5	Freq. ref.	Open	Open	Analog input 1	Closed	Open	Preset Freq. 1	Open	Closed	Preset Freq. 2	Closed	Closed	Preset Freq. 3
		DI4	DI5	Freq. ref.																
		Open	Open	Analog input 1																
		Closed	Open	Preset Freq. 1																
		Open	Closed	Preset Freq. 2																
Closed	Closed	Preset Freq. 3																		
15	DI5	Digital input 5																		
16	DI6	Digital input 6	Fault reset																	
17	CM	Common for DI1-DI6	*)																	
mA	↔	18	AO1+	Analogue signal (+output)	Output frequency															
		19	AO1-/GND	Analogue output common / I/O ground																
-	-	30	+24Vin	24V auxiliary input voltage																
		A	RS485	Serial bus, negative	Modbus RTU BACnet, N2															
		B	RS485	Serial bus, positive																
RUN	⊗	21	RO1 NC	Relay output 1	RUN															
		22	RO1 CM																	
		23	RO1 NO																	
		24	RO2 NC	Relay output 2	FAULT															
		25	RO2 CM																	
		26	RO2 NO																	
32	RO3 CM	Relay output 3	READY																	
33	RO3 NO																			

Figure 50. The signals of the control terminals on the standard I/O board, and a connection example. If you include the optional code +SBF4 in your order, the relay output 3 is replaced with a thermistor input.

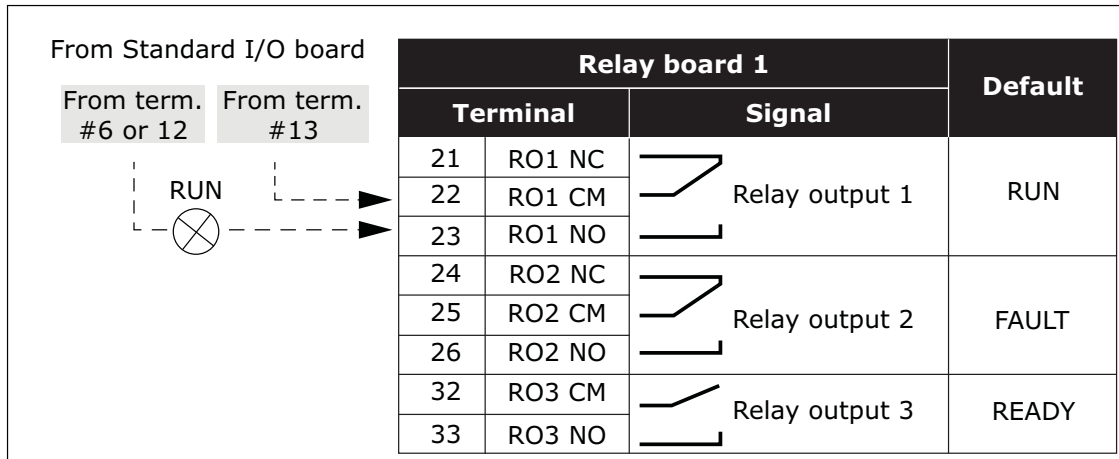

Figure 51. The standard relay board

#### 6.1.2.1 Selection of terminal functions with DIP switches

You can make 2 selections with the DIP switches for specified terminals. The switches have 2 positions: up and down. You can see the location of the DIP switches and the possible selections in Figure 52.

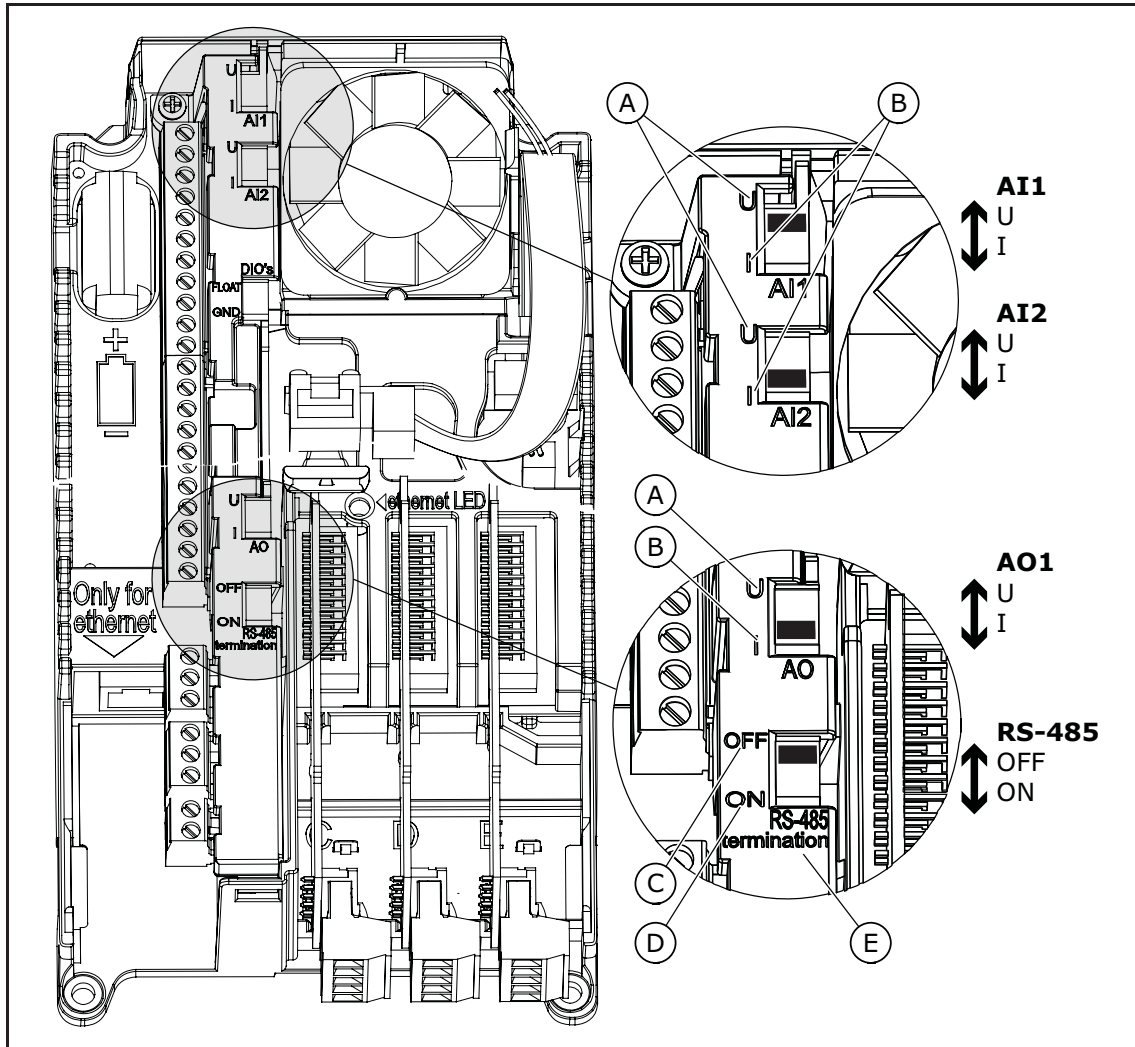

Figure 52. The selections of the DIP switches

- A. The voltage signal (U), 0-10 V input
- B. The current signal (I), 0-20 mA input
- C. OFF
- D. ON
- E. The RS-485 bus termination

The DIP switch	The default position
AI1	U
AI2	I
AO1	I
RS485 bus termination	OFF

Table 16. The default positions of the DIP switches

### 6.1.2.2 Isolation of digital inputs from ground

It is possible to isolate from ground the digital inputs (terminals 8-10 and 14-16) on the standard I/O board. To do this, change the position of a DIP switch on the control board.

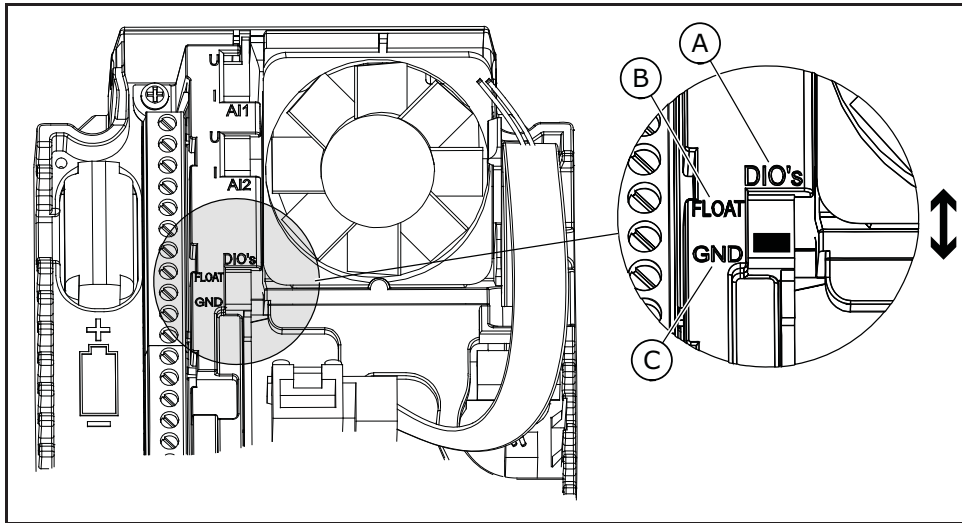

Figure 53. Change the position of this switch to isolate the digital inputs from ground

- A. The digital inputs
- B. Floating
- C. Connected to GND (default)

## 6.2 Fieldbus Connection

You can connect the drive to fieldbus with an RS485 or an Ethernet cable. If you use an RS485 cable, connect it to terminal A and B of the standard I/O board. If you use an Ethernet cable, connect it to the Ethernet terminal below the cover of the drive.

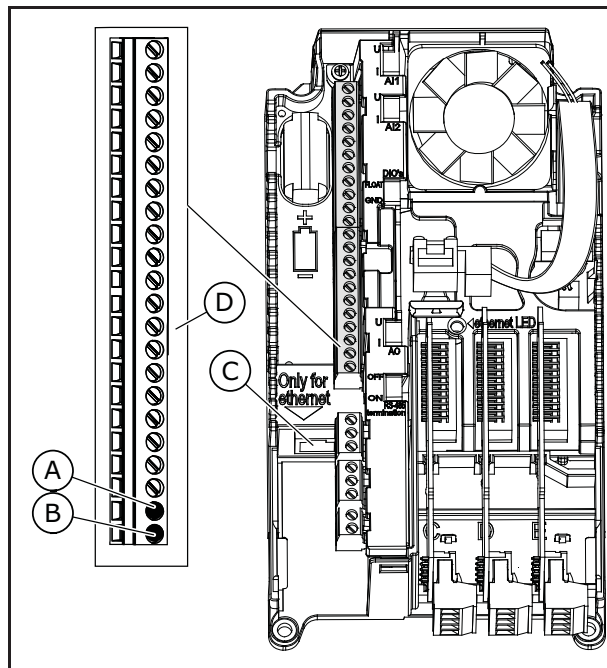

Figure 54. The Ethernet and RS485 connections

- A. RS485 terminal A = Data -
- B. RS485 terminal B = Data +
- C. The Ethernet terminal
- D. The control terminals

### 6.2.1 Using Fieldbus Through an Ethernet Cable

Item	Description
The plug type	A shielded RJ45 plug, maximum length 40 mm (1.57 in)
The cable type	CAT5e STP
The cable length	Maximum 100 m (328 ft)

Table 17. Ethernet cable data

#### 6.2.1.1 ETHERNET CABLING

**1** Connect the Ethernet cable to its terminal.

**2**

In IP21, cut free the opening on the cover of the AC drive for the Ethernet cable. In IP54, cut a hole in a grommet and move the cable through it.

- If the grommet folds in when you put the cable, pull the cable back to make the grommet straight.
- The hole in the grommet must not be wider than your cable.
- Pull the first bit of the cable out of the grommet so that it stays straight. If this is not possible, make the connection tight with some insulation tape or a cable tie.

**IP21**

**IP54**

**3**

Put the cover of the drive back. Keep the distance between the Ethernet cable and the motor cable at a minimum of 30 cm (11.81 in).

See more in the Installation Manual of the fieldbus that you have.

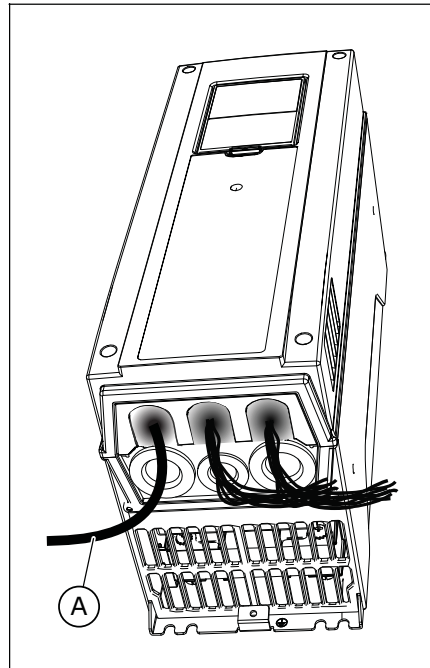

**A. The Ethernet cable in IP21**

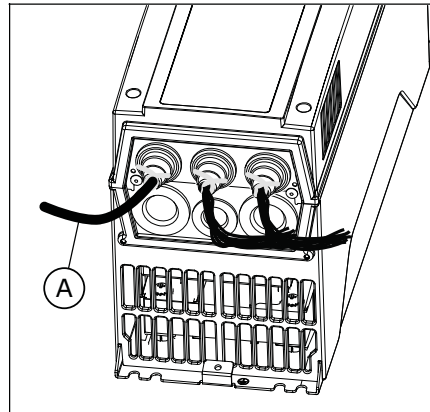

**A. The Ethernet cable in IP54**



### 6.2.2 Using Fieldbus Through an RS485 Cable

Item	Description
The plug type	2.5 mm <sup>2</sup>
The cable type	STP (shielded twisted pair), Belden 9841 or almost the same
The cable length	So that it agrees with the fieldbus. See the fieldbus manual.

Table 18. RS485 cable data

#### RS485 CABLING

1	<p>Remove approximately 15 mm (0.59 in) of the grey shield of the RS485 cable. Do this for the 2 fieldbus cables.</p> <ol style="list-style-type: none"> <li>a. Strip the cables for approximately 5 mm (0.20 in) to put them in the terminals. Do not keep more than 10 mm (0.39 in) of the cable outside the terminals.</li> <li>b. Strip the cable at such a distance from the terminal that you can attach it to the frame with the grounding clamp for control cable. Strip the cable at a maximum length of 15 mm (0.59 in). Do not remove the aluminium shield of the cable.</li> </ol>	
---	--	--

2

Connect the cable to the standard I/O board of the drive, in terminals A and B.

- A = negative
- B = positive

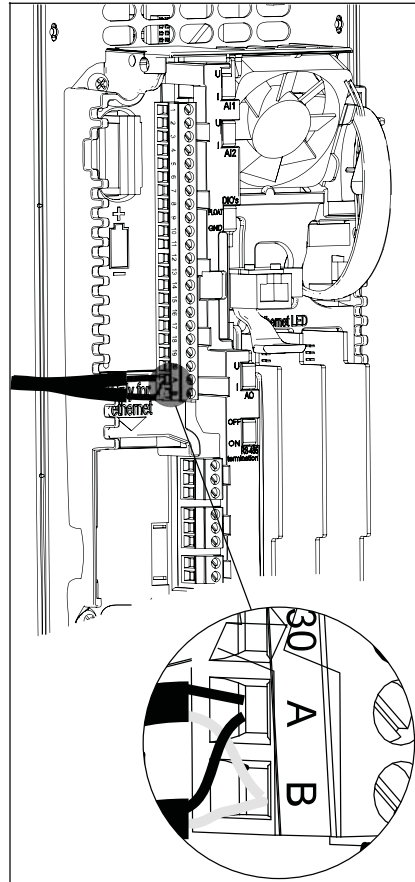

3

Attach the shield of the cable to the frame of the drive with a grounding clamp for control cable to make a grounding connection.

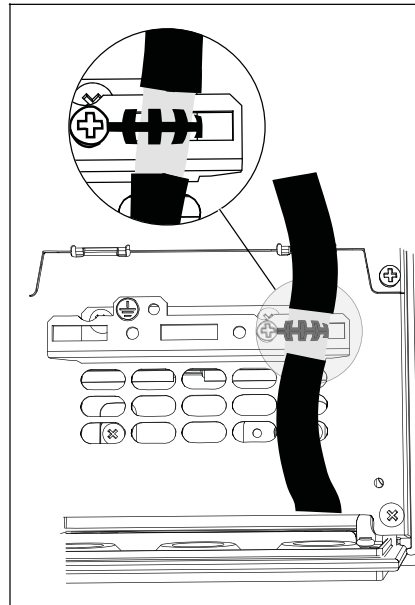

4

If the drive is the last device on the field-bus line, set the bus termination.

- a. Find the DIP switches on the left side of the control unit of the drive.
- b. Set the DIP switch of the RS485 bus termination to the ON position.
- c. Biasing is built in the bus termination resistor. The termination resistance is 220 Ω.

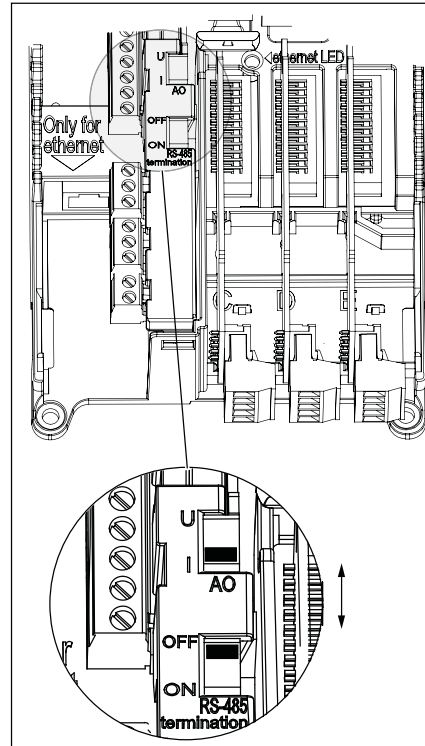

5

In IP21, unless you have cut the openings for other cables, cut an opening on the cover of the drive for the RS485 cable.

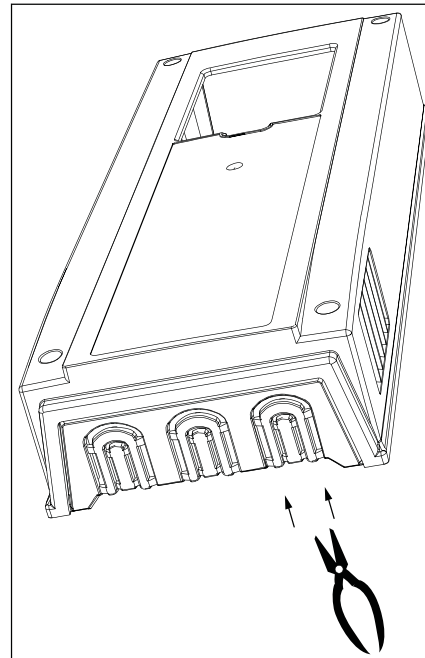

6

Put the cover of the drive back. Pull the RS485 cables to the side.

- a. Keep the distance of the Ethernet, I/O and Fieldbus cables from the motor cable at a minimum of 30 cm (11.81 in).
- b. Move the fieldbus cables away from the motor cable.

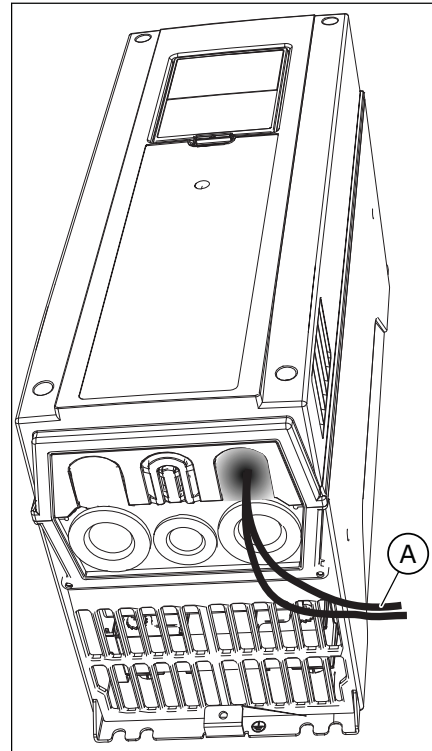

**A. The fieldbus cables**

7

Set the bus termination for the first and the last device of the fieldbus line. We recommend that the first device on the fieldbus is the master device.

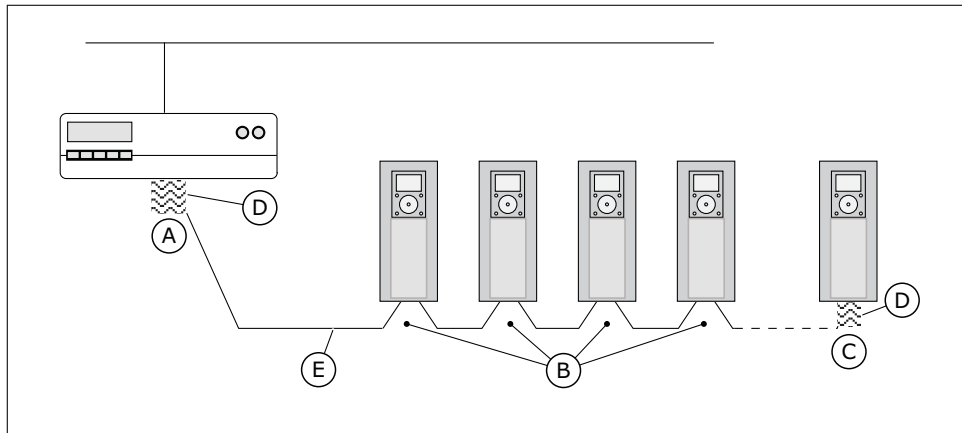

- |   |  |
|---|--|
| A. The termination is activated                   | B. The termination is deactivated                |
| C. The termination is activated with a DIP switch | D. The bus termination. The resistance is 220 Ω. |
| E. The fieldbus                                   |  |

Note: If you do power-down to the last device, there is no bus termination.

### 6.3 Installation of Option Boards

**⚠ CAUTION!**

Do not install, remove, or replace option boards on the drive when the power is on. Doing this can cause damage to the boards.

Install the option boards into the option board slots of the drive. Refer to Table 19.

Type of the option board	Description of the option board	The correct slot or slots
HVFDSDOPT6DI	The I/O expander board	C, D, E
HVFDSDOPT2RO1T	The Thermistor relay board	C, D, E
HVFDSDOPT1AI2AO	The I/O expander board	C, D, E
HVFDSDOPT3RO	The Relay board	C, D, E
HVFDSDOPT1RO5DI	The I/O expander board	C, D, E
HVFDOPPTMP	The Temperature measurement board	C, D, E
32006630-001	The LonWorks fieldbus board	D, E

Table 19. The option boards and their correct option board slots

#### THE INSTALLATION PROCEDURE

1

Open the cover of the AC drive.

**⚠ WARNING**  
Do not touch the control terminals. They can have a dangerous voltage also when the drive is disconnected from mains.

**2**

If you have an HVFDSDOPT or an 32006630-001 option board, make sure that the label on it says "dv" (dual voltage). This shows that the option board is compatible with the drive.

Note: It is not possible to install option boards that are not compatible with the drive.

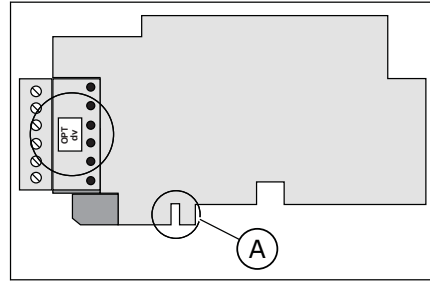

**A. The slot coding**

**3**

To get access to the option board slots, open the cover of the control unit.

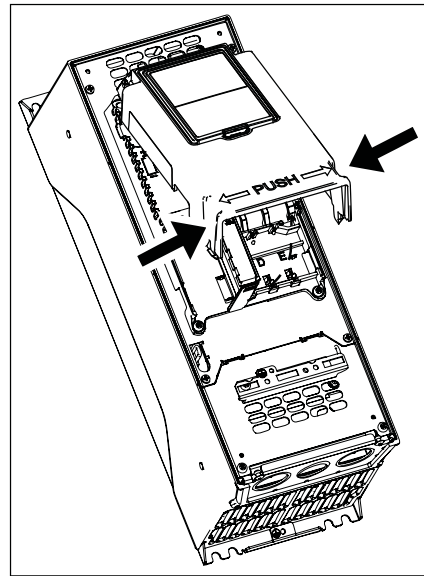

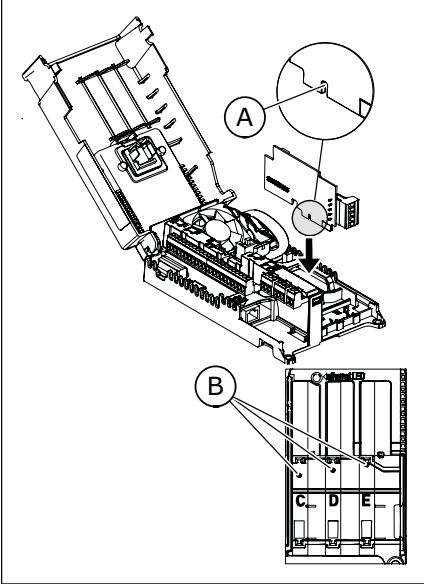
<b>4</b>	<p>Install the option board into the correct slot: C, D or E. See Table 19.</p> <p>a. The option board has a slot coding, because of which it is not possible to install the option board in an incorrect slot.</p>	 <p><b>A. The slot coding</b> <b>B. The option board slots</b></p>
----------	---	--

<b>5</b>	Close the cover of the control unit. Put the cover of the AC drive back.
----------	--

#### 6.4 Installation of a Battery for the Real Time Clock (RTC)

To use the Real Time Clock (RTC), you must install a battery in the drive.

<b>1</b>	Use a ½ AA battery with 3.6 V and a capacity of 1000-1200 mAh. You can use, for example, a Panasonic BR-1/2 AA or a Vitzrocell SB-AA02.
----------	---

<b>2</b>	Install the battery on the left side of the control panel. See Figure 49 on page 47.
----------	--

The battery will last approximately 10 years. See more about the functions of the RTC in the Application Manual.

### 6.5 Galvanic Isolation Barriers

The control connections are isolated from mains. The GND terminals are permanently connected to I/O ground.

The digital inputs on the standard I/O board can be galvanically isolated from the I/O ground. To isolate the digital inputs, use the DIP switch that has the positions FLOAT and GND.

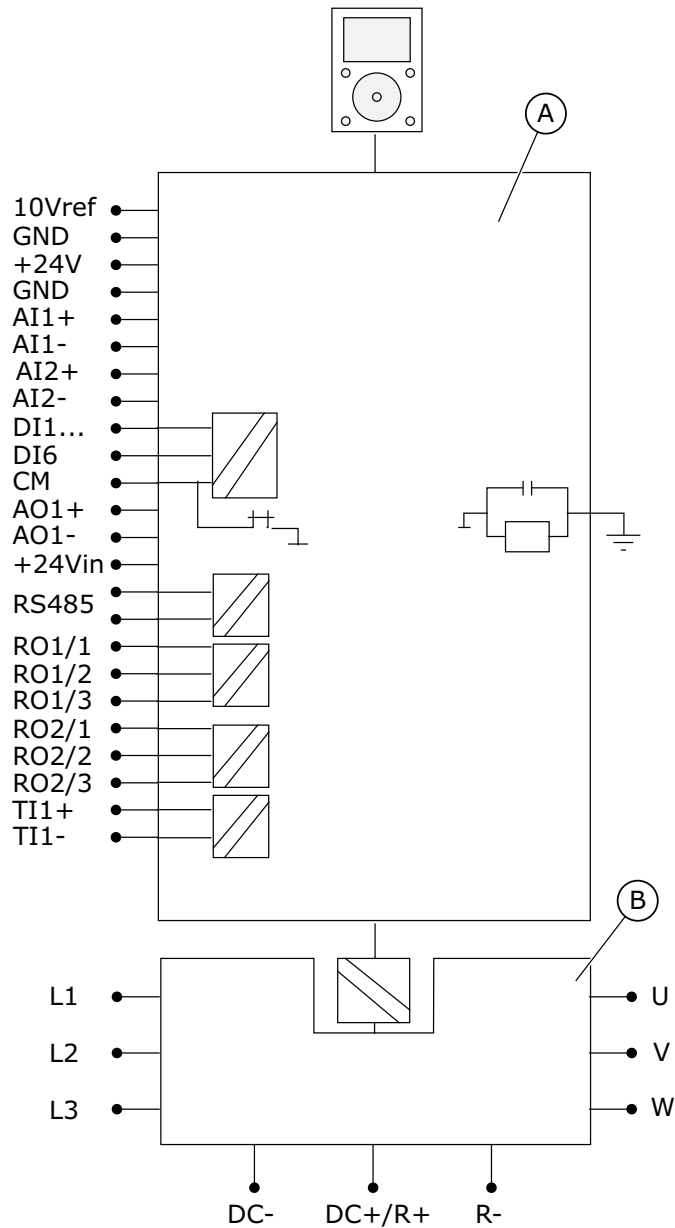

Table 20. The galvanic isolation barriers

A. The control unit

B. The power unit



## 7. MAINTENANCE

In normal conditions, the AC drive is maintenance-free. However, regular maintenance is recommended to ensure a trouble-free operation and a long lifetime of the drive. We recommend to follow the table below for maintenance intervals.

**NOTE:** Because of capacitor type (thin film capacitors), reforming of capacitors is not necessary.

Maintenance interval	Maintenance action
Regularly and according to general maintenance interval	<ul style="list-style-type: none"> <li>• Check tightening torques of terminals</li> </ul>
6–24 months (depending on environment)	<ul style="list-style-type: none"> <li>• Check input and output terminals and control I/O terminals.</li> <li>• Check operation of cooling fan</li> <li>• Check for corrosion on terminals, busbars and other surfaces</li> </ul>
24 months	Clean heatsink and cooling tunnel
3–6 years	Change internal IP54 fan
6–10 years	Change main fan

*Table 1. Maintenance*

## 8. PRODUCT DATA

### 8.1 Power ratings

#### 8.1.1 Mains voltage 208-240 V

<b>Mains voltage 208-240V, 50-60 Hz, 3~</b>					
Converter type	Loadability		Motor shaft power		
	Low*		230 supply	208-240V supply	
	Rated continuous current $I_L$ [A]	10% overload current [A]	10% overload 40°C [kW]	10% overload 40°C [hp]	
<b>MR4</b>	<b>A 0007</b>	<b>3.7</b>	<b>4.1</b>	<b>0.55</b>	<b>0.75</b>
	<b>A 0010</b>	<b>4.8</b>	<b>5.3</b>	<b>0.75</b>	<b>1.0</b>
	<b>A 0015</b>	<b>6.6</b>	<b>7.3</b>	<b>1.1</b>	<b>1.5</b>
	<b>A 0020</b>	<b>8.0</b>	<b>8.8</b>	<b>1.5</b>	<b>2.0</b>
	<b>A 0030</b>	<b>11.0</b>	<b>12.1</b>	<b>2.2</b>	<b>3.0</b>
	<b>A 0040</b>	<b>12.5</b>	<b>13.8</b>	<b>3.0</b>	<b>4.0</b>
<b>MR5</b>	<b>A 0050</b>	<b>18.0</b>	<b>19.8</b>	<b>4.0</b>	<b>5.0</b>
	<b>A 0075</b>	<b>24.2</b>	<b>26.4</b>	<b>5.5</b>	<b>7.5</b>
	<b>A 0100**</b>	<b>31.0</b>	<b>34.1</b>	<b>7.5</b>	<b>10.0</b>
<b>MR6</b>	<b>A 0150</b>	<b>48.0</b>	<b>52.8</b>	<b>11.0</b>	<b>15.0</b>
	<b>A 0200**</b>	<b>62.0</b>	<b>68.2</b>	<b>15.0</b>	<b>20.0</b>
<b>MR7</b>	<b>A 0250</b>	<b>75.0</b>	<b>82.5</b>	<b>18.5</b>	<b>25.0</b>
	<b>A 0300</b>	<b>88.0</b>	<b>96.8</b>	<b>22.0</b>	<b>30.0</b>
	<b>A 0400</b>	<b>105.0</b>	<b>115.5</b>	<b>30.0</b>	<b>40.0</b>
<b>MR8</b>	<b>A 0500</b>	<b>143.0</b>	<b>154.0</b>	<b>37.0</b>	<b>50.0</b>
	<b>A 0600</b>	<b>170.0</b>	<b>187.0</b>	<b>45.0</b>	<b>60.0</b>
	<b>A 0750</b>	<b>208.0</b>	<b>225.5</b>	<b>55.0</b>	<b>75.0</b>
<b>MR9</b>	<b>A 1000</b>	<b>261.0</b>	<b>287.1</b>	<b>75.0</b>	<b>100.0</b>
	<b>A 1250</b>	<b>310.0</b>	<b>341.0</b>	<b>90.0</b>	<b>125.0</b>

\* See chapter 8.1.4.

\*\* Given low loadabilities valid for 230V drives at a switching frequency of 4kHz

Table 20. Power ratings, supply voltage 208-240V.

**NOTE:** The rated currents in given ambient temperatures (in Table 3) are achieved only when the switching frequency is equal to or less than the factory default.

8.1.2 Mains voltage 380-480V

<b>Mains voltage 380-480V, 50-60 Hz, 3~</b>					
Converter type	Loadability		Motor shaft power		
	Low*		400V supply	480V supply	
	Rated continuous current $I_L$ [A]	10% overload current [A]	10% overload 104°F [kW]	10% overload 104°F [HP]	
<b>MR4</b>	<b>C 0015</b>	<b>3.4</b>	<b>3.7</b>	<b>1.1</b>	<b>1.5</b>
	<b>C 0020</b>	<b>4.8</b>	<b>5.3</b>	<b>1.5</b>	<b>2.0</b>
	<b>C 0030</b>	<b>5.6</b>	<b>6.2</b>	<b>2.2</b>	<b>3.0</b>
	<b>C 0040</b>	<b>8.0</b>	<b>8.8</b>	<b>3.0</b>	<b>4.0</b>
	<b>C 0050</b>	<b>9.6</b>	<b>10.6</b>	<b>4.0</b>	<b>5.0</b>
	<b>C 0075**</b>	<b>12.0</b>	<b>13.2</b>	<b>5.5</b>	<b>7.5</b>
<b>MR5</b>	<b>C 0100</b>	<b>16.0</b>	<b>17.6</b>	<b>7.5</b>	<b>10</b>
	<b>C 0150</b>	<b>23.0</b>	<b>25.3</b>	<b>11.0</b>	<b>15.0</b>
	<b>C 0200**</b>	<b>31.0</b>	<b>34.1</b>	<b>15.0</b>	<b>20.0</b>
<b>MR6</b>	<b>C 0250</b>	<b>38.0</b>	<b>41.8</b>	<b>18.5</b>	<b>25.0</b>
	<b>C 0300</b>	<b>46.0</b>	<b>50.6</b>	<b>22.0</b>	<b>30.0</b>
	<b>C 0400**</b>	<b>61.0</b>	<b>67.1</b>	<b>30.0</b>	<b>40.0</b>
<b>MR7</b>	<b>C 0500</b>	<b>72.0</b>	<b>79.2</b>	<b>37.0</b>	<b>50.0</b>
	<b>C 0600</b>	<b>87.0</b>	<b>95.7</b>	<b>45.0</b>	<b>60.0</b>
	<b>C 0750</b>	<b>105.0</b>	<b>115.5</b>	<b>55.0</b>	<b>75.0</b>
<b>MR8</b>	<b>C 1000</b>	<b>140.0</b>	<b>154.0</b>	<b>75</b>	<b>100</b>
	<b>C 1250</b>	<b>170.0</b>	<b>187.0</b>	<b>90</b>	<b>125</b>
	<b>C 1500</b>	<b>205.0</b>	<b>225.5</b>	<b>110</b>	<b>150</b>
<b>MR9</b>	<b>C 2000</b>	<b>261.0</b>	<b>287.1</b>	<b>132</b>	<b>200</b>
	<b>C 2500</b>	<b>310.0</b>	<b>341.0</b>	<b>160</b>	<b>250</b>

\* See chapter 8.1.4

\*\* Given low loadabilities valid for 480V drives at a switching frequency of 4kHz

Table 1. Power ratings, supply voltage 380-480V.

**NOTE:** The rated currents in given ambient temperatures (in Table 3) are achieved only when the switching frequency is equal to or less than the factory default.

8.1.3 Mains voltage 525-600V

<b>Mains voltage 525-600V, 50-60 Hz, 3~</b>				
Converter type	Loadability			Motor shaft power
	Low*			600V supply
	Rated continuous current $I_L$ [A]	10% overload current [A]	10% overload current [A]	104°F [HP]
<b>MR5</b>	D0030	3.9	4.3	3.0
	D0050	6.1	6.7	5.0
	D0075	9.0	9.9	7.5
	D0100	11.0	12.1	10.0
<b>MR6</b>	D0150	18.0	19.8	15.0
	D0200	22.0	24.2	20.0
	D0250	27.0	29.7	25.0
	D0300	34.0	37.4	30.0
<b>MR7</b>	D0400	41.0	45.3	40.0
	D0500	52.0	57.2	50.0
	D0600	62.0	68.2	60.0
<b>MR8</b>	D0750	88.0	154.0	75.0
	D1000	110.0	187.0	100.0
	D1250	137.5	225.5	125.0
<b>MR9</b>	D1500	144.0	158.4	150.0
	D2000	208.0	228.8	200.0

\* See chapter 8.1.4

Table 2. Power ratings, supply voltage 525-600V.

### 8.1.4 Definitions of overloadability

**Low overload** = Following continuous operation at rated output current  $I_L$ , the converter is fed with  $110\% * I_L$  for 1 min, followed by a period of  $I_L$ .

Example: If the duty cycle requires  $110\%$  rated current  $I_L$  for 1 min in every 10 min, the remaining 9 min must be at rated current or less.

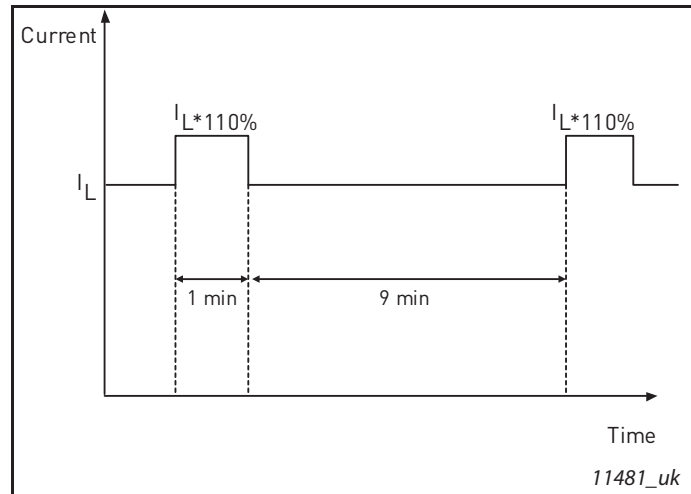

Figure 1. Low overload

## 8.2 SmartVFD HVAC - technical data

<b>Mains connection</b>	Input voltage $U_{in}$	208...240V; 380...480V; 525...600V; -10%...+10%
	Input frequency	47...66 Hz
	Connection to mains	Once per minute or less
	Starting delay	4 s (MR4 to MR6); 6 s (MR7 to MR9)
<b>Motor connection</b>	Output voltage	0- $U_{in}$
	Continuous output current	$I_L$ : Ambient temperature max. +104°F, overload 1.1 x $I_L$ (1 min./10 min.)
	Starting current	$I_S$ for 2 s every 20 s
	Output frequency	0...320 Hz (standard)
	Frequency resolution	0.01 Hz
<b>Control characteristics</b>	Switching frequency (see parameter M3.1.2.1)	200-500 V <ul style="list-style-type: none"> <li>• MR4-MR6:</li> <li>• 1.5-10 kHz</li> <li>• Default: 6 kHz (except for A 0040, A 0100, A 0200, C 0075, C 0200 and C 0400: 4 kHz)</li> <li>• MR7-MR9:</li> <li>• 1.5-6 kHz</li> <li>• Default: MR7: 4 kHz, MR8: 3 kHz, MR9: 2 kHz</li> </ul> 600 V <ul style="list-style-type: none"> <li>• MR5-MR9:</li> <li>• 1.5-6 kHz</li> <li>• Default: 2 kHz</li> <li>• For a product that is configured for a C4 installation on IT network the maximum switching frequency is limited to default 2kHz.</li> </ul> Automatic switching frequency derating in case of overload.
	Frequency reference Analogue input Panel reference	Resolution 0.1% (10-bit), accuracy $\pm 1\%$ Resolution 0.01 Hz
	Field weakening point	8...320 Hz
	Acceleration time	0.1...3000 sec
	Deceleration time	0.1...3000 sec

<b>Ambient conditions</b>	Ambient operating temperature	$I_L$ : -10°C (no frost)...+40°C, 14 (no frost) ... 104 F Up to 50 °C with derating (1.5%/1°C)
	Storage temperature	-40°C ... +70°C -40°F...+158°F
	Relative humidity	0 to 95% R <sub>H</sub> , non-condensing, non-corrosive
	Air quality: chemical vapours mechanical particles	IEC 60721-3-3, unit in operation, class 3C2 IEC 60721-3-3, unit in operation, class 3S2
	Altitude	100% load capacity (no derating) up to 1,000 m / 3280 ft 1-% derating for each 100m/328ft above 1,000m/3280ft <u>Max. altitudes:</u> <b>208...240V:</b> 4,500m/14763 ft (TN and IT systems) <b>380...480V:</b> 4,500m/14763 ft (TN and IT systems) <b>525...690 V:</b> 2,000m/6562 ft (TN and IT systems, no corner grounding) <u>Voltage for I/O signals:</u> Up to 2,000m/6561ft : Allowed up to <b>240V</b> 2,000m...4,500m / 6561...14763ft: Allowed up to <b>120V</b>
<b>Ambient conditions (cont.)</b>	Vibration EN61800-5-1/ EN60068-2-6	5...150 Hz <b>Displacement amplitude</b> 1 mm (peak) at 5...15.8 Hz (MR4...MR9) <b>Max acceleration amplitude</b> 1 G at 15.8...150 Hz (MR4...MR9)
	Shock EN61800-5-1 EN60068-2-27	UPS Drop Test (for applicable UPS weights) Storage and shipping: max 15 G, 11 ms (in package)
	Enclosure class	IP21/NEMA 1 standard in entire kW/HP range IP54/NEMA12 option Note! Keypad required for IP54/NEMA12

<b>EMC (at default settings)</b>	Immunity	Fulfils EN61800-3 (2004), first and second environment						
	Emissions	<p>Depend on EMC level.</p> <p>+EMC2: EN61800-3 (2004), Category C2 Honeywell Smart VFD HVAC will be delivered with class C2 EMC filtering, if not otherwise specified.</p> <p>Honeywell Smart VFD HVAC can be modified for IT-networks. See chapter 5.2.</p> <ul style="list-style-type: none"> <li>• 200-500 V: EN 61800-3 (2004), category C2.</li> <li>• 600 V: EN 61800-3 (2004), category C3.</li> <li>• All: The product is configurable to category C4 for installation on IT networks. The drive can be modified for IT type mains. See chapter 7.6 Installation in an IT system. The IP00 / UL Open Type drive has by default category C4.</li> </ul>						
<b>Emissions</b>	Average noise level (cooling fan) sound power level in dB(A)	<table style="width: 100%; border: none;"> <tr> <td style="width: 50%;">MR4: 65</td> <td style="width: 50%;">MR7: 77</td> </tr> <tr> <td>MR5: 70</td> <td>MR8: 86</td> </tr> <tr> <td>MR6: 77</td> <td>MR9: 87</td> </tr> </table>	MR4: 65	MR7: 77	MR5: 70	MR8: 86	MR6: 77	MR9: 87
MR4: 65	MR7: 77							
MR5: 70	MR8: 86							
MR6: 77	MR9: 87							
<b>Safety</b>		EN 61800-5-1 (2007), CE, cUL; (see unit nameplate for more detailed approvals)						
<b>Control connections</b>	<b>See chapter 8.2.1.</b>							
<b>Protections</b>	Overvoltage trip limit	Yes						
	Undervoltage trip limit	Yes						
	Ground fault protection	In case of ground fault in motor or motor cable, only the drive is protected						
	Mains supervision	Yes						
	Motor phase supervision	Trips if any of the output phases is missing						
	Overcurrent protection	Yes						
<b>Protections (cont.)</b>	Unit overtemperature protection	Yes						
	Motor overload protection	Yes						
	Motor stall protection	Yes						
	Motor underload protection	Yes						
	Short-circuit protection of +24V and +10V reference voltages	Yes						

Table 3. Smart VFD HVAC technical data



8.2.1 Technical information on control connections

<b>Basic I/O board</b>		
<b>Terminal</b>	<b>Signal</b>	<b>Technical information</b>
<b>1</b>	Reference output	+10V, +3%; Maximum current 10 mA
<b>2</b>	Analogue input, voltage or current	Analogue input channel 1 0- +10V (Ri = 200 kΩ) 4-20 mA (Ri =250 Ω) Resolution 0.1 %, accuracy ±1 % Selection V/mA with dip-switches (see page 50)
<b>3</b>	Analogue input common (current)	Differential input if not connected to ground; Allows ±20V differential mode voltage to GND
<b>4</b>	Analogue input, voltage or current	Analogue input channel 1 Default:4-20 mA (Ri =250 Ω) 0-10 V (Ri=200kΩ) Resolution 0.1 %, accuracy ±1 % Selection V/mA with dip-switches (see page 50)
<b>5</b>	Analogue input common (current)	Differential input if not connected to ground; Allows 20V differential mode voltage to GND
<b>6</b>	24V aux. voltage	+24VDC, ±10%, max volt. ripple < 100mVrms; max. 250mA Dimensioning: max. 1000mA/control box. Short-circuit protected
<b>7</b>	I/O ground	Ground for reference and controls (connected internally to frame ground through 1MΩ)
<b>8</b>	Digital input 1	Positive or negative logic Ri = min. 5kΩ 18...30V = "1"
<b>9</b>	Digital input 2	
<b>10</b>	Digital input 3	
<b>11</b>	Common A for DIN1-DIN6	Digital inputs can be disconnected from ground, see chapter 6.1.2.2.
<b>12</b>	24V aux. voltage	+24VDC, ±10%, max volt. ripple < 100mVrms; max. 250mA Dimensioning: max. 1000mA/control box. Short-circuit protected
<b>13</b>	I/O ground	Ground for reference and controls (connected internally to frame ground through 1MΩ)
<b>14</b>	Digital input 4	Positive or negative logic Ri = min. 5kΩ 18...30V = "1"
<b>15</b>	Digital input 5	
<b>16</b>	Digital input 6	
<b>17</b>	Common A for DIN1-DIN6	Digital inputs can be disconnected from ground, see chapter 6.1.2.2.
<b>18</b>	Analogue signal (+output)	Analogue output channel 1, selection 0 -20mA, load <500 Ω Default:0-20 mA 0-10V Resolution 0.1 %, accuracy ±2 % Selection V/mA with dip-switches (see page 50)
<b>19</b>	Analogue output common	
<b>30</b>	24V auxiliary input voltage	Can be used as external power backup for the control unit (and fieldbus)
<b>A</b>	RS485	Differential receiver/transmitter Set bus termination with dip switches (see page 50)
<b>B</b>	RS485	

Table 4. Technical information on basic I/O board

<b>Relay board 1</b>	Relay board with two Type 8A/STST and one Type 8A/STDT relays. 5,5 mm isolation between channels. External interface connector See chapter 6.	
<b>21</b>	Relay output 1*	Switching capacity 24VDC/8A
<b>22</b>		250VAC/8A
<b>23</b>		125VDC/0.4A Min. switching load 5V/10mA
<b>24</b>	Relay output 2*	Switching capacity 24VDC/8A
<b>25</b>		250VAC/8A
<b>26</b>		125VDC/0.4A Min. switching load 5V/10mA
<b>32</b>	Relay output 3*	Switching capacity 24VDC/8A
<b>33</b>		250VAC/8A 125VDC/0.4A Min. switching load 5V/10mA

\* If 230VAC is used as control voltage from the output relays, the control circuitry must be powered with a separate isolation transformer to limit short circuit current and overvoltage spikes. This is to prevent welding on the relay contacts. Refer to standard EN 60204-1, section 7.2.9

*Table 5. Technical information on Relay board 1*



**Home and Building Technologies**

In the U.S.:

Honeywell

715 Peachtree Street NE

Atlanta, GA 30308

[customer.honeywell.com](http://customer.honeywell.com)

© U.S. Registered Trademark  
© 2018 Honeywell International Inc.  
38-00007—03 M.S. Rev. 01-18  
Printed in U.S.A.

**Honeywell**

Subject to change without notice