



Installation, Operation & Maintenance

ACT/ACTF Air Separators

402-108

SUPERSEDES: NEW

EFFECTIVE: August 4, 2021

DESCRIPTION:

The ACT/ACTF air separator is an ASME vessel designed with openings in a large diameter chamber to create and maintain a vortex where air can separate and be removed from the circulating water. The ACT/ACTF is designed and constructed in accordance with ASME section VIII, Division 1. This product is intended for hot and chilled water closed loop systems though alternate materials may be chosen to accommodate other applications.

INSTALLATION:

The ACT/ACTF air separator should be installed at the point of lowest solubility of air within the system fluid.

Where the temperature is the highest -

After the boiler and/or heat exchanger or before the chiller.

Where the pressure is the lowest -

Prior to the pump suction or at the top of a system.

As with all hydronic systems, it is recommended to have the expansion tank connection to the system on the suction side of the pump. A base ring comes standard on eight inch and larger connection units. The flow must be directed to the inlet connection of the separator. The flow should enter in the top connection and exit through the bottom connection. Nozzles are not designed to handle external pipe loads.

Be aware of the type of expansion tank to be installed in your system as this will impact the installation of the air separator.

BLADDER TYPE EXPANSION TANK SYSTEM:

Bladder style expansion tanks are used in "air elimination" systems. An automatic air vent is to be installed in the connection at the top of the ACT, ATC & ACTF. Automatic vents can also be installed at other high points in the system to assure an air free system. Refer to Taco instruction sheets 402-015, 402-002, 402-093, 402-020 & 402-100 for installation information on bladder or diaphragm expansion tanks.

PLAIN STEEL TYPE EXPANSION TANK SYSTEM:

Plain steel expansion tanks are used in "air control" systems. It is critical to the proper operation of air control systems that the air be redirected back to the expansion tank from the air separator.

In a plain steel expansion tank system, manual valves are to be used for initial venting. A tee should be installed in the vent connection at the top of the ACT/ACTF with piping from the branch connection of the tee piped to the expansion tank. The top line connection should be piped to a manual vent valve to allow initial venting of the system. Manual valves can be installed in other high points of the system to facilitate initial venting of the system. Be sure to have a 3 degree slope in the branch piping going from the tee to the PS tank. (See diagram) A gate valve should be installed in line connecting the ACT/ACTF to the expansion tank connection to facilitate servicing of the expansion tank.

WARNING: Be sure to make provisions to accommodate the weight of the ACT/ACTF when filled with water. Failure to follow these instructions could result in injury or death and property damage.

MAINTENANCE:

A manual blow down valve is to be added to the blow down connection at the bottom of the ACT/ACTF air separator. The function of the manual blow down is to facilitate the purging of sediment from the bottom of the ACT/ACTF. A regular inspection schedule should be adopted and carried out by properly trained personnel to examine the pressure vessel for corrosion and its cause, extent and possible arrest, to determine minimum metal thicknesses, maximum metal

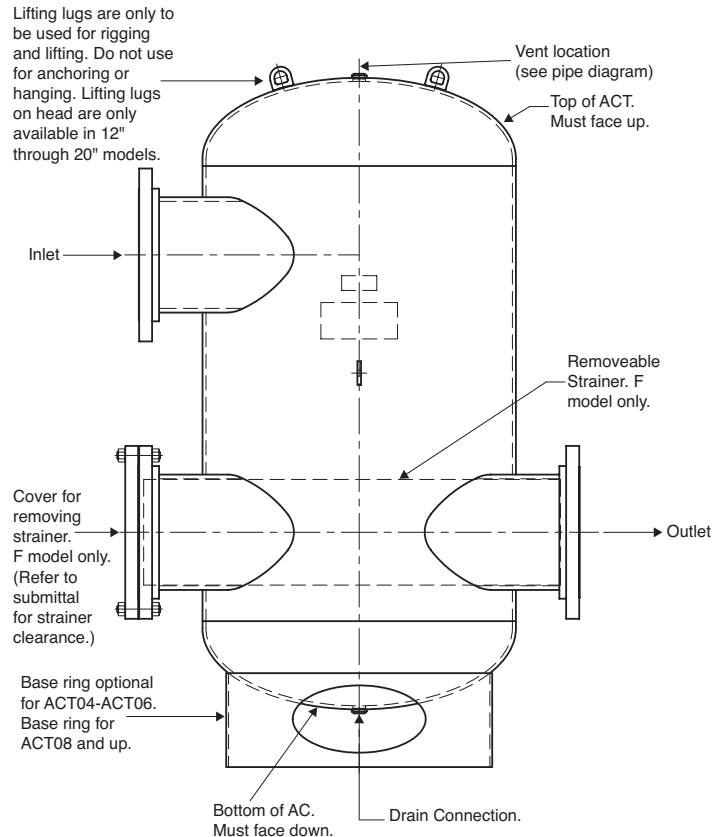

NAMEPLATE

A	123456	CERTIFIED BY:	<input type="checkbox"/>
	MAWP-S 125	PSI AT 240	°F
	MAWP-T	PSI AT	°F
	MDMT -20	°F AT 125	PSI
	PART No. AC06F-125		
	CRN No. 12345	DATE 10-2014	
	MADE IN U.S.A.		
	B	C	D

A. National Board Number B. CRN Number C. Model Number D. Date

temperatures, and calculation of reduction in allowable working pressure and to conduct hydrostatic tests. Also, defects such as cracks, laminations and distortion of shell, heads or connections should be noted and repaired if possible, after consultation with and acceptance by a commissioned authorized inspector who shall be involved at all stages of any repairs or alterations of the ASME vessel.

ACF MODELS



WARNING: Before performing any maintenance procedure it is important to read and understand the instructions. **Be sure to allow the system water temperature to cool to below 100 degrees before performing maintenance to prevent; property damage injury, serious bodily injury or death.**



WARNING: Leakage, corrosion or indications of damage are signs of an impending serious failure of the ACT/ACTF. Periodically inspect for damage and if noted the ACT/ACTF must be serviced or replaced. **Failure to follow these instructions could result in serious personal injury or death and property damage.**

1. ACFT models have a strainer that is serviced by removing the blind flange from the connection opposite the inlet connection. Isolation valves must be installed upstream and downstream the ACTF unit. Once isolation valves are in the off position, the associated pumps and heat sources should be shut down and locked out. You can then remove the blind flange and stainless steel strainer for cleaning.
2. When reinstalling the strainer, make sure the leading end engages with the inlet nozzle to support the strainer. If the strainer is not engaged, you will not be able to reinstall the blind flange.
3. Check the gasket surface for residual gasket material. Clean and install new gasket to ensure proper sealing. The flanges

used on these vessels are standard ANSI flanges and standard ANSI ring Gaskets can be used. The bottom of the ACT/ACTF may need to be cleaned periodically. This is particularly the case during the initial startup period. Opening the manual blow down valve for a few seconds should dislodge accumulated dirt from the bottom of the tank.

FABRICATED STEEL VERSIONS OF THIS MODEL ARE NOT FOR USE IN DOMESTIC (POTABLE) WATER SYSTEMS:

Domestic, potable or fresh water can cause serious corrosion when in direct contact with carbon steel. This can result in leakage and property damage. Do not use for domestic, potable or fresh water. Failure to follow this instruction may result in serious personal injury and property damage.

TYPICAL PIPING DIAGRAMS

AIR SEPARATOR WITH CAPTIVE AIR TANK (DIAGRAM 1)

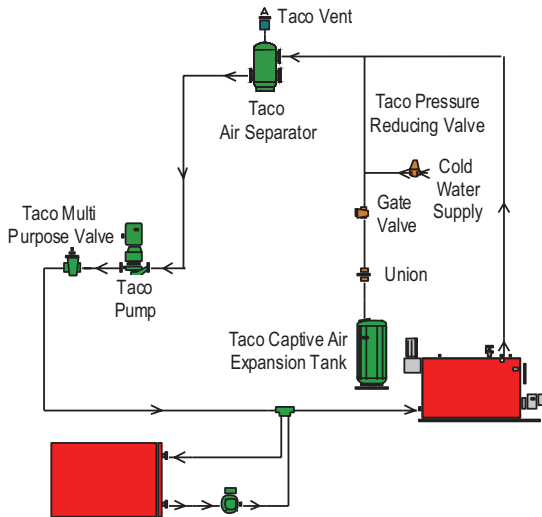

AIR SEPARATOR WITH PLAIN STEEL TANK (DIAGRAM 2)

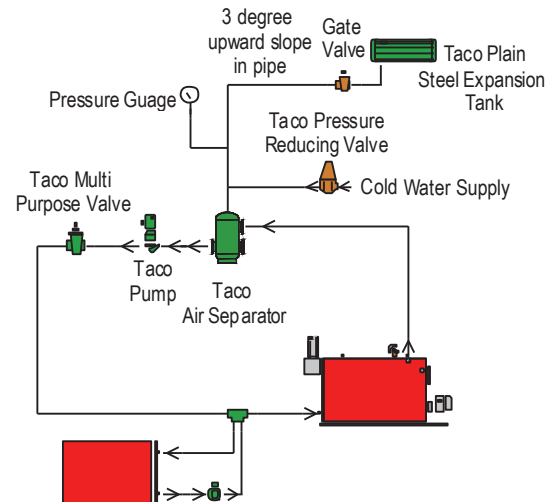

AIR SEPARATOR IN HEATING SYSTEM (DIAGRAM 3)

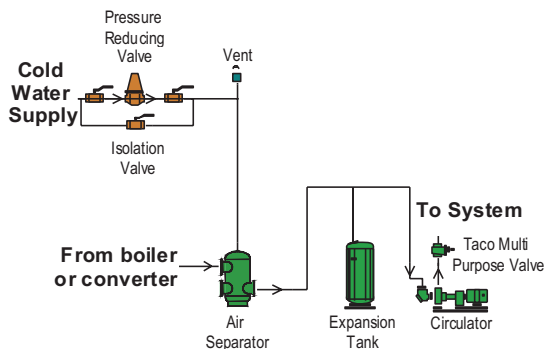

AIR SEPARATOR IN COOLING SYSTEM (DIAGRAM 4)

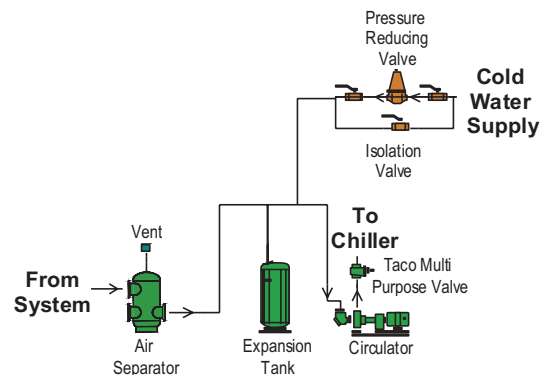

Taco Comfort Solutions A Taco Family Company

Taco, Inc., 1160 Cranston Street, Cranston, RI 02920 | Tel: (401) 942-8000 | FAX: (401) 942-2360

Taco (Canada), Ltd., 8450 Lawson Road, Suite #3, Milton, Ontario L9T 0J8 | Tel: (905) 564-9422 | FAX: (905) 564-9436

Visit our web site: www.TacoComfort.com | Printed in USA | ©2021 Taco, Inc.

