

Suction Diffuser Rear Strainer Pullout (RSP) with Integral Cast Straightening Vanes

SUPERSEDES: December 5, 2013

EFFECTIVE: July 15, 2017

Plant I.D. 001-4219

LOCATION & INSTALLATION:

1. Locate and install pump per pump manufacturer's instructions.
NOTE: When selecting pump location, ensure there is sufficient space available to remove the Suction Diffuser straightening vane assembly and strainer for routine maintenance. Clearance requirements are shown as dimension "C" in Table 1.
2. Mount suction diffuser directly to pump suction flange. Pump and suction diffuser flanges should be aligned before connections are made. Piping should **NEVER** be drawn into place by force. Inlet connection is labeled with the word "SYSTEM" on the flange and outlet flange is labeled "PUMP".
3. Both suction and discharge piping should be suspended or supported close to the pump so that no pipe weight rests on pump. To support the Suction Diffuser, cut a piece of 1¼" pipe without threads to the approximate length required from one of the bosses provided on the pump connection to the adjustable foot nut. See Figure 1: Piping Diagram.
4. Place pipe on nut and under the boss and turn the nut counter-clockwise until sufficient load is supplied to give maximum support.

MOUNTING:

1. Suction Diffusers can be mounted in a vertical or horizontal position. Bosses are cast into the Suction Diffuser body to accommodate pipe supports for each position.
2. If used in a horizontal position, the pump should be positioned at right angles to the piping.
3. A blow down valve may be installed on the drain connection of the Suction Diffuser.



NOTE: Blow down is **MOST** effective when system connection of the Suction Diffuser is in the 12 o'clock position.

4. When insulating the Suction Diffuser, allowances need to be made for removal of the straightening vane assembly and cleaning of the strainer.

TABLE 1: STRAIGHTENING VANE AND STRAINER CLEARANCE DIMENSION

Model Number	System	Pump	C	Model Number	System	Pump	C
SD020015-5	2 Flanged	1½ Flanged	8.49 (216)	SD060060-5	6 Flanged	6 Flanged	19.02 (483)
SD020020-5	2 Flanged	2 Flanged	8.24 (209)	SD080060-5	8 Flanged	6 Flanged	
SD025020-5	2½ Flanged	2 Flanged		8.97 (228)	SD100060-5	10 Flanged	6 Flanged
SD030020-5	3 Flanged	2 Flanged	SD080080-5		8 Flanged	8 Flanged	
SD025025-5	2½ Flanged	2½ Flanged	10.47 (266)	SD100080-5	10 Flanged	8 Flanged	29.40 (747)
SD030025-5	3 Flanged	2½ Flanged		SD120080-5	12 Flanged	8 Flanged	
SD040025-5	4 Flanged	2½ Flanged	12.86 (327)	SD100100-5	10 Flanged	10 Flanged	33.72 (856)
SD030030-5	3 Flanged	3 Flanged		SD120100-5	12 Flanged	10 Flanged	
SD040030-5	4 Flanged	3 Flanged	15.36 (390)	SD140100-5	14 Flanged	10 Flanged	34.00 (864)
SD050030-5	5 Flanged	3 Flanged		SD120120-5	12 Flanged	12 Flanged	
SD040040-5	4 Flanged	4 Flanged	15.36 (390)	SD140120-5	14 Flanged	12 Flanged	34.00 (864)
SD050040-5	5 Flanged	4 Flanged		SD160120-5	16 Flanged	12 Flanged	
SD060040-5	6 Flanged	4 Flanged	15.36 (390)	SD140140-5	14 Flanged	14 Flanged	34.00 (864)
SD050050-5	5 Flanged	5 Flanged		SD160140-5	16 Flanged	14 Flanged	
SD060050-5	6 Flanged	5 Flanged	15.36 (390)				
SD080050-5	8 Flanged	5 Flanged					

NOTE: Dimensions are in inches. Metric dimensions are in millimeters and are in parentheses ().

FIGURE 1: PIPING DIAGRAM

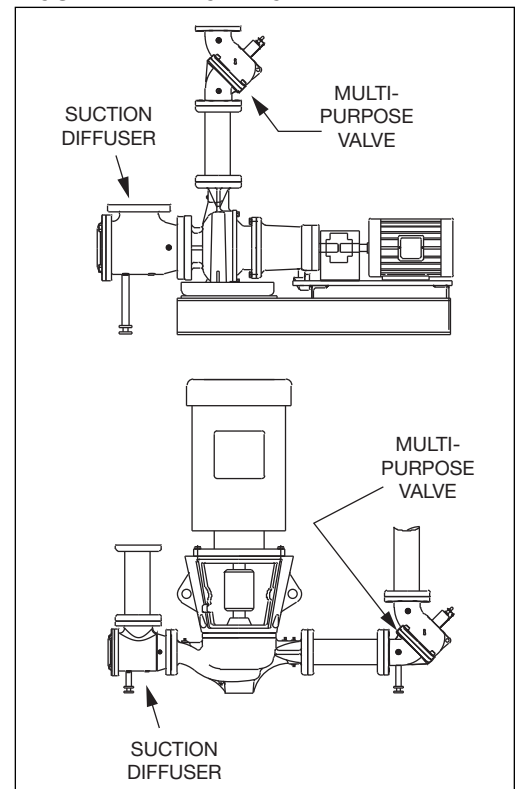

START-UP STRAINER REMOVAL:

The fine mesh start up strainer should be removed after initial system fluid circulation and proper system cleaning.

1. Shut the pump off and close the service valves to isolate the Suction Diffuser and pump from the system. Allow enough time for the system fluid to cool below 100° F (38° C).
2. Once isolated remove drain plug on bottom of Suction Diffuser and allow system pressure to drop to zero (if installed this may be accomplished by opening the blow down valve).
3. Loosen the cover bolts on the rear of the Suction Diffuser and carefully break it loose from the Suction Diffuser body. Once all drainage has stopped completely remove the bolts and cover from the Suction Diffuser body.
4. Remove the strainers from the Suction Diffuser body.
5. Remove the fine mesh start up strainer (if still in place) and discard appropriately.
6. Inspect all components for any damage and replace any damaged components as necessary.
7. Inspect cover "O" ring and replace as necessary.
8. Reinstall the permanent strainer into Suction Diffuser body. Making sure that the permanent strainer is properly seated inside of Suction Diffuser body, reattach the cover and secure in place by tightening the bolts in criss-cross pattern.
9. Open isolation valves slowly while inspecting the "O" ring sealing area for leaks.
10. Return system to normal operating conditions.

CLEANING:

1. It is recommended that valved gauge connections be provided on diffuser inlet and pump suction connections to indicate when cleaning is needed.
2. Note pressure drop when strainer is clean. When the pressure drop increases 100%, remove the strainer and clean.

NOTE: Follow the same procedures in the START-UP STRAINER REMOVAL section when performing routine maintenance and cleaning of the permanent strainer.

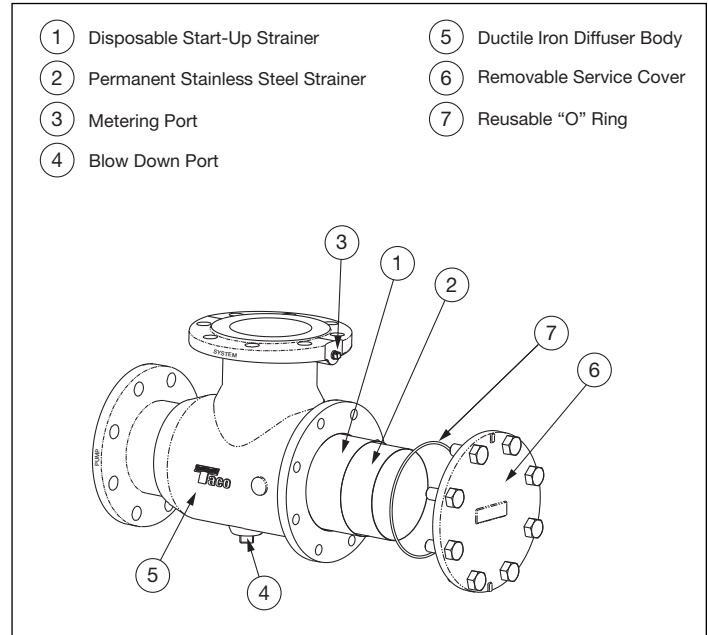

LIMITED WARRANTY STATEMENT

Taco, Inc. will repair or replace without charge (at the company's option) any product or part which is proven defective under normal use within one (1) year from the date of start-up or one (1) year and six (6) months from date of shipment (whichever occurs first).

In order to obtain service under this warranty, it is the responsibility of the purchaser to promptly notify the local Taco stocking distributor or Taco in writing and promptly deliver the subject product or part, delivery prepaid, to the stocking distributor. For assistance on warranty returns, the purchaser may either contact the local Taco stocking distributor or Taco. If the subject product or part contains no defect as covered in this warranty, the purchaser will be billed for parts and labor charges in effect at time of factory examination and repair.

Any Taco product or part not installed or operated in conformity with Taco instructions or which

has been subject to misuse, misapplication, the addition of petroleum-based fluids or certain chemical additives to the systems, or other abuse, will not be covered by this warranty.

If in doubt as to whether a particular substance is suitable for use with a Taco product or part, or for any application restrictions, consult the applicable Taco instruction sheets or contact Taco at [401-942-8000].

Taco reserves the right to provide replacement products and parts which are substantially similar in design and functionally equivalent to the defective product or part. Taco reserves the right to make changes in details of design, construction, or arrangement of materials of its products without notification.

TACO OFFERS THIS WARRANTY IN LIEU OF ALL OTHER EXPRESS WARRANTIES. ANY WARRANTY IMPLIED BY LAW INCLUDING WARRANTIES OF MERCHANTABILITY OR

FITNESS IS IN EFFECT ONLY FOR THE DURATION OF THE EXPRESS WARRANTY SET FORTH IN THE FIRST PARAGRAPH ABOVE.

THE ABOVE WARRANTIES ARE IN LIEU OF ALL OTHER WARRANTIES, EXPRESS OR STATUTORY, OR ANY OTHER WARRANTY OBLIGATION ON THE PART OF TACO.

TACO WILL NOT BE LIABLE FOR ANY SPECIAL, INCIDENTAL, INDIRECT OR CONSEQUENTIAL DAMAGES RESULTING FROM THE USE OF ITS PRODUCTS OR ANY INCIDENTAL COSTS OF REMOVING OR REPLACING DEFECTIVE PRODUCTS.

This warranty gives the purchaser specific rights, and the purchaser may have other rights which vary from state to state. Some states do not allow limitations on how long an implied warranty lasts or on the exclusion of incidental or consequential damages, so these limitations or exclusions may not apply to you.

Taco Comfort Solutions A Taco Family Company

Taco, Inc., 1160 Cranston Street, Cranston, RI 02920 | Tel: (401) 942-8000 | FAX: (401) 942-2360

Taco (Canada), Ltd., 8450 Lawson Road, Suite #3, Milton, Ontario L9T 0J8 | Tel: (905) 564-9422 | FAX: (905) 564-9436

Visit our web site: www.TacoComfort.com | Printed in USA | ©2017 Taco, Inc.

