

MC 950

True Condenser Microphone

Order # 730.262



FEATURES

- Flexible true condenser microphone
- Supercardioid polar pattern
- Outstanding clear and detailed sound
- Switchable pre-attenuation (-15dB) and low-cut filter
- High sensitivity
- High impulse fidelity and good transient response
- Handcrafted in Germany

APPLICATION

The MC 950 is a flexible true condenser microphone with switchable -15 dB attenuation and low-cut filter. If you appreciate a clear sound and high impulse fidelity of small-diaphragm condenser microphones, our MC 950 is the right choice.

Due to its largely linear frequency response with gentle treble boost, the MC 950 microphone is suitable for use with a variety of signal sources such as piano, choir, orchestra or solo instruments of any kind. Due to its supercardioid polar pattern, the MC 950 can be used where sound from the rear is to be reliably attenuated, as it provides the most effective sound suppression at 140° and 220°.

The microphone also delivers excellent results for speech and vocal recordings - we recommend the optionally available WS 101 wind shield for speech and vocal recordings from a short distance as well as for outdoor recordings.

TECHNICAL SPECIFICATIONS

Transducer type	True condenser
Operating principle	Pressure gradient
Frequency response	40 - 20,000 Hz
Polar pattern	Supercardioid
Sensitivity (0 dB = 1 V/Pa)	.35 mV/Pa (= -29 dBV)
Nominal impedance	180 Ω
Load impedance	1000 Ω
Max. SPL	
at 1 kHz	124 dB
with pre-attenuation	139 dB
Signal-to-noise ratio rel. to 1 Pa	72 dB
A-weighted equivalent SPL	15 dB
Low-cut filter	switchable, 6 dB/octave at 250 Hz
Power supply	11 - 52 V phantom power
Current consumption	4.6 mA
Connector	3-pin XLR, male
Dimensions:	
Length	128 mm
Diameter	21 mm
Weight	106 g

SUPPLIED ACCESSORY

MA-CL 21 Microphone clamp. Order # 727.946

OPTIONAL ACCESSORIES

EA 19/25	Elastic suspension 19 - 25 mm, incl. MA-CL 36 microphone clamp. Order # 407.194
WS 101	Wind shield, charcoal-grey Order # 111.244
WS 53	Wind shield, small, charcoal-grey. Order # 436.607



beyerdynamic

CREATE THE AMAZING

MC 950

True Condenser Microphone

Order # 730.262

FREQUENCY RESPONSE & POLAR PATTERN

This frequency response curve and polar pattern correspond to a typical production sample for this microphone.

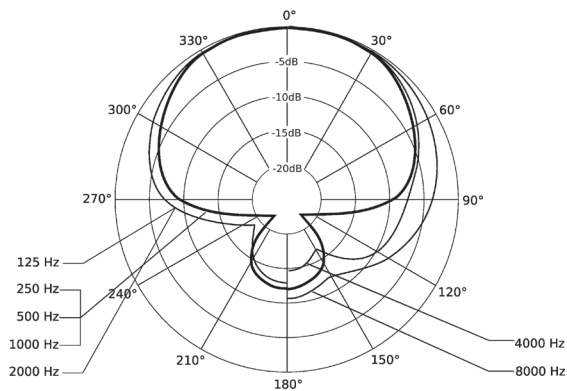
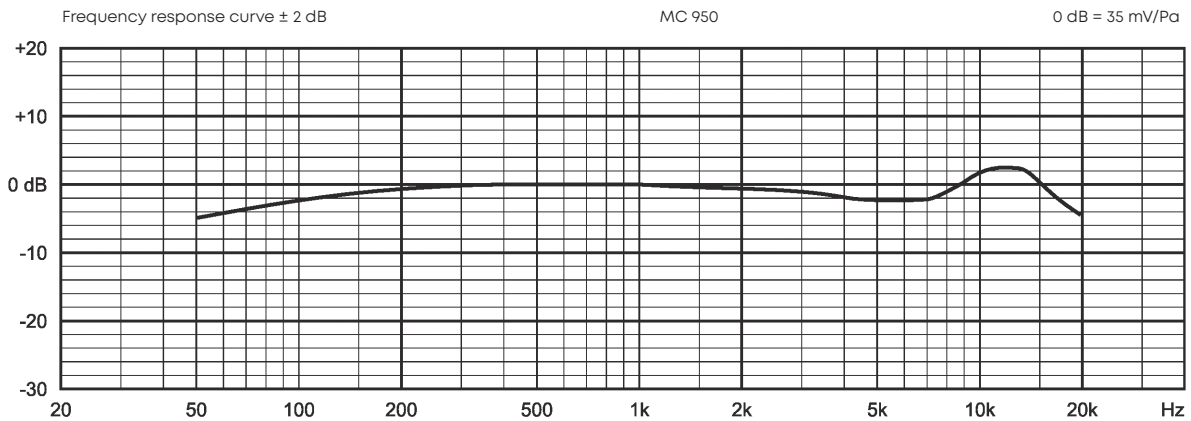

CREATE THE AMAZING



beyerdynamic

beyerdynamic GmbH & Co. KG
Theresienstr. 8 · 74072 Heilbronn / Germany
Tel. +49 (0) 71 31 / 617 - 300 · info@beyerdynamic.de · www.beyerdynamic.com

2/2

For further distributors worldwide, please go to www.beyerdynamic.com
Non-contractual illustrations. Contents subject to change without notice. E5/MC 950 (09.23)