



PL-150

Crystallite Series
Granite Composite Sinks

Features

- Single Bowl
- Available in 7 Colors
- Stain / Scratch / Fade Resistant
- Made in Germany



Color Pictured: Onyx
*Pictured with Matching Onyx Strainer

Material



- Pure Quartz Sand with High Grade Acrylic Binders

Installation

- Undermount

Available Color/Finishes

Intended for reference only

Color	Description
	Alpina
	Chroma
	Concrete
	Gunmetal
	Mocha
	Onyx
	Sand

6140 Ulmerton Road Clearwater, FL 33760
Phone: (727) 388-9895
Fax: (727) 362-1281

For the most current Specification Sheet, go to www.buildpelican.com





PL-150

Crystallite Series
Granite Composite Sinks

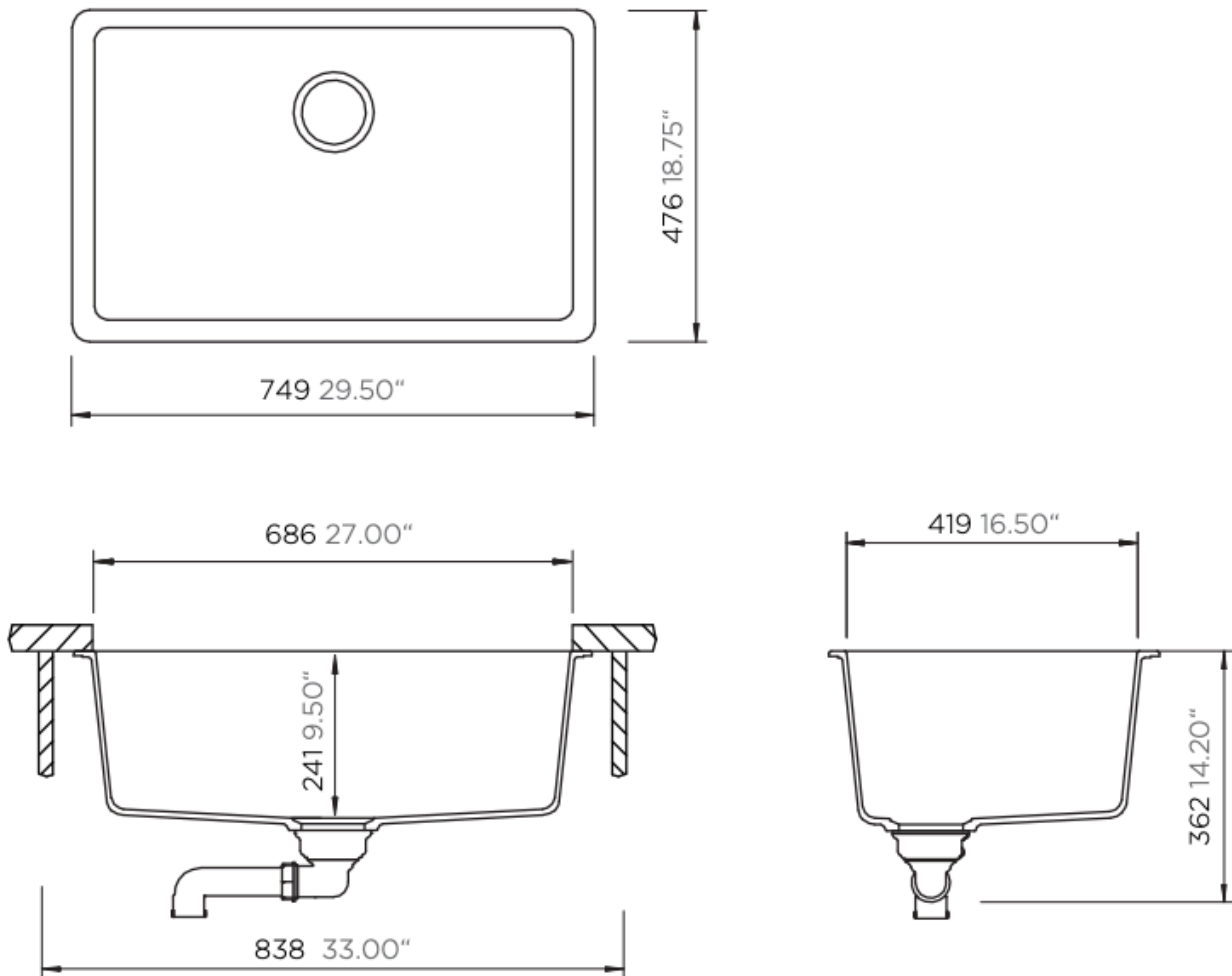

Technical Information

All product dimensions are nominal

Exterior Measurements: 29.50" x 18.75" x 9.50"

Interior Measurements: 27.00" x 16.50" x 9.50"

Bowl Configuration: Single

Installation Information

Install this product according to the installation instructions.

Limited Lifetime Warranty

See website for detailed warranty information.

6140 Ulmerton Road Clearwater, FL 33760

Phone: (727) 388-9895

Fax: (727) 362-1281

For the most current Specification Sheet, go to www.buildpelican.com

