

Bronze Threaded, Solder, NIBCO® Press System and Grooved Ball Valves

NIB-SEAL® Technical Data

NIBCO bronze ball valves installed with NIB-SEAL® insulated handles are the only approach that keeps your insulated piping system completely intact.

The revolutionary NIB-SEAL insulated handle system used with a NIBCO bronze ball valve, stops condensate, cold. Its unique thermal barrier design keeps moisture from infiltrating your insulated system while preventing thermal energy loss through exposed metal handles.

Designed for new installations or retrofitting existing systems, NIB-SEAL bronze ball valves offer a wide range of advantages for typical commercial HVAC systems as well as industrial applications where insulated piping is desirable.

In addition, the NIB-SEAL handle was tested to UL 2043 and is UL listed for installation in air-handling spaces (plenums).

- Protective sleeve provides a stationary surface to affix the insulation, allowing operation of the valve without destroying the integrity of the insulated system.
- High-strength cylindrical handle design features easy access to standard adjustable memory stop for system balancing.
- Cap and insulating plug provide a vapor seal to prevent exchange of air, to maximize the efficiency of your insulated piping system.
- Position indicators allow at-a-glance determination of whether valve is in open or closed position.
- Preformed hole allows for convenient tagging.

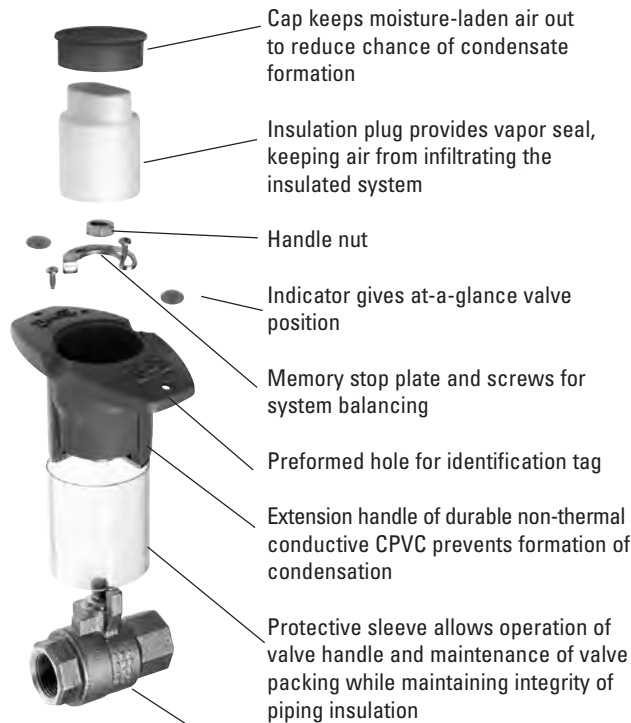

Temperature range: 15° F to 250° F

Not intended for steam applications in excess of 15 PSI

NIBCO two-piece or three-piece bronze ball valve is an integral part of the NIB-SEAL valve system

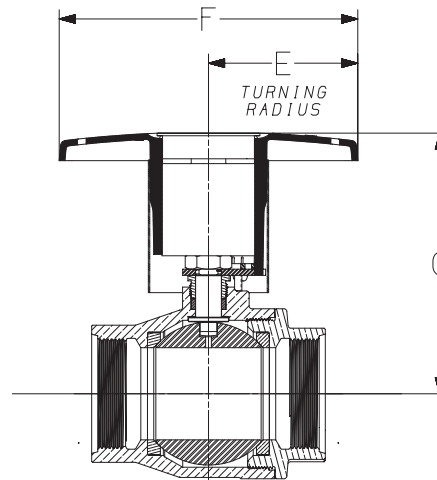

Size	Dimensions					
	Valve Series 580-70*/590*			Valve Series 585-70/595		
	C	E	F	C	E	F
.250	—	—	—	3.750	2.188	4.25
.375	—	—	—	3.750	2.188	4.25
.500	3.750	2.188	4.25	3.750	2.188	4.25
.750	3.750	2.188	4.25	4.000	2.188	4.25
1.000	4.000	2.188	4.25	4.25	2.188	4.25
1.250	4.250	2.188	4.25	5.375	3.375	6.50
1.500	5.375	3.375	6.50	5.563	3.375	6.50
2.000	5.563	3.375	6.50	5.875	3.375	6.50
2.500	5.875	3.375	6.50	—	—	—

*Use 585-70/595 for 1/4" - 1"

For bronze ball valves with factory-installed NIB-SEAL insulated handle, order appropriate NIBCO valve figure number with suffix "NS."

Example: T-585-70-NS, 1/2"

NIB-SEAL on sweat ball valves are shipped unassembled.

Sample Specification

For piping systems requiring up to 2" of insulation, specify a non-conductive CPVC extended-handle bronze ball valve tested to UL 2043, is UL listed for installation in air handling spaces (plenums), that offers a vapor seal, adjustable memory stop, position indicators and convenient valve packing maintenance—all without disturbing the insulation. Specify NIB-SEAL insulated handle.

Example: T-585-70-NS

Visit our website for the most current information.