

NIB-SEAL® Locking Handle

U.S. PATENT 9,810,344

The patented technology of the 3-in-1 NIB-SEAL locking handle solves three problems at once: **it extends, it insulates, and it locks**. The innovative locking handle design extends valve actuation to provide ample room for insulating around piping systems, and its unique thermal barrier system prevents heat transfer and condensate development. The NIB-SEAL locking handle also allows the valve to be locked in the full open or closed position to prevent incidental actuation.

Designed for new installations, the NIB-SEAL locking handle is engineered to work with NIBCO® bronze ball valves.**

Applications: For piping systems requiring up to 2" of insulation, specify a non-conductive CPVC extended-locking handle bronze ball valve tested to UL 2043, and UL listed for installation in air handling spaces. The assembly offers a vapor seal, position indicators, locking device, and actuation without disturbing the insulation. Designed for new installations, the NIB-SEAL locking handle installed on bronze ball valves offers a wide range of advantages for typical commercial HVAC systems as well as industrial applications where insulated piping with a locking device is desirable. Specify NIB-SEAL insulated locking handle.

Approvals: UL 2043

Safety Lock Compatibility: Cable lock as small as 1/8" diameter to padlock as big as 0.33" diameter shackle.

Temperature Range: 15° F to 250° F

Not intended for steam applications in excess of 15 PSI.

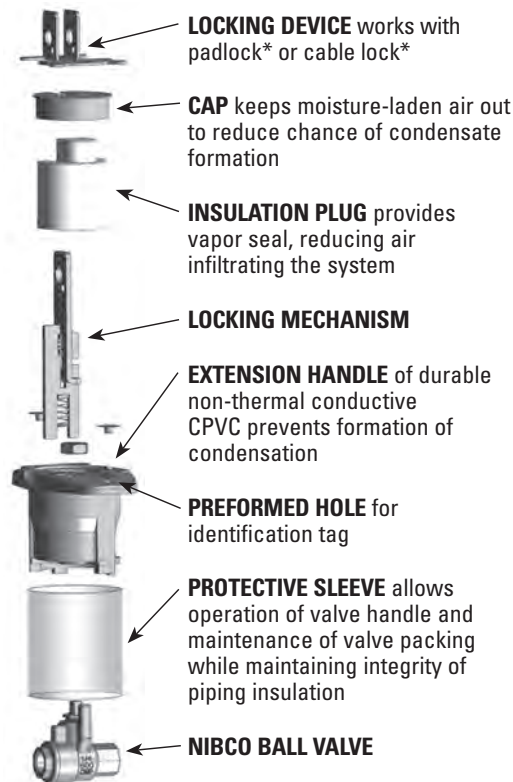
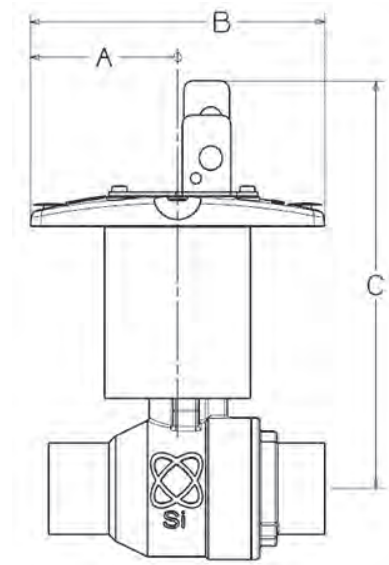

Dimensions

Series 585						
Sizes	A		B		C	
	In.	mm.	In.	mm.	In.	mm.
1/4"	2.19	55.58	4.25	107.95	5.30	134.59
3/8"	2.19	55.58	4.25	107.95	5.30	134.58
1/2"	2.19	55.58	4.25	107.95	5.42	137.56
3/4"	2.19	55.58	4.25	107.95	5.69	144.50
1"	2.19	55.58	4.25	107.95	5.88	149.40
1 1/4"	3.38	85.73	6.50	165.10	6.84	173.67
1 1/2"	3.38	85.73	6.50	165.10	7.06	179.33
2"	3.38	85.73	6.50	165.10	7.30	185.44

Factory installed only.

Order appropriate factory installed NIBCO valve figure number with suffix "LX". Example: T-585-70-LX, 1/2"

NIB-SEAL on solder/sweat ball valves are shipped unassembled.

* Padlock and cable lock not included

** Valve type showing above is just for handle representation

Visit our website for the most current information.