

CME-PlusTM

Kit assembly

Installation and operating instructions



English (US) Installation and operating instructions

Original installation and operating instructions

CONTENTS

	Page
1. Limited warranty	3
2. Symbols used in this document	3
3. General	3
4. Shipment inspection	3
5. Kit assembly	4
5.2 Assemble the tank/transducer manifold	4
5.3 Attach the tank	5
6. Install the pump	5
6.1 Set the pump parameters	5
6.2 Perform functional test	5



Warning

Prior to installation, read these installation and operating instructions. Installation and operation must comply with local regulations and accepted codes of good practice.



Warning

The use of this product requires experience with and knowledge of the product. Persons with reduced physical, sensory or mental capabilities must not use this product, unless they are under supervision or have been instructed in the use of the product by a person responsible for their safety. Children must not use or play with this product.

1. Limited warranty

Products manufactured by GRUNDFOS PUMPS CORPORATION (Grundfos) are warranted to the original user only to be free of defects in material and workmanship for a period of 24 months from date of installation, but not more than 30 months from date of manufacture. Grundfos' liability under this warranty shall be limited to repairing or replacing at Grundfos' option, without charge, F.O.B. Grundfos' factory or authorized service station, any product of Grundfos' manufacture. Grundfos will not be liable for any costs of removal, installation, transportation, or any other charges which may arise in connection with a warranty claim. Products which are sold but not manufactured by Grundfos are subject to the warranty provided by the manufacturer of said products and not by Grundfos' warranty. Grundfos will not be liable for damage or wear to products caused by abnormal operating conditions, accident, abuse, misuse, unauthorized alteration or repair, or if the product was not installed in accordance with Grundfos' printed installation and operating instructions.

To obtain service under this warranty, the defective product must be returned to the distributor or dealer of Grundfos' products from which it was purchased together with proof of purchase and installation date, failure date, and supporting installation data. Unless otherwise provided, the distributor or dealer will contact Grundfos or an authorized service station for instructions. Any defective product to be returned to Grundfos or a service station must be sent freight prepaid; documentation supporting the warranty claim and/or a Return Material Authorization must be included if so instructed.

GRUNDFOS WILL NOT BE LIABLE FOR ANY INCIDENTAL OR CONSEQUENTIAL DAMAGES, LOSSES, OR EXPENSES ARISING FROM INSTALLATION, USE, OR ANY OTHER CAUSES. THERE ARE NO EXPRESS OR IMPLIED

WARRANTIES, INCLUDING MERCHANTABILITY OR FITNESS FOR A PARTICULAR PURPOSE, WHICH EXTEND BEYOND THOSE WARRANTIES DESCRIBED OR REFERRED TO ABOVE.

Some jurisdictions do not allow the exclusion or limitation of incidental or consequential damages and some jurisdictions do not allow limit actions on how long implied warranties may last. Therefore, the above limitations or exclusions may not apply to you. This warranty gives you specific legal rights and you may also have other rights which vary from jurisdiction to jurisdiction.

2. Symbols used in this document



Warning

If these safety instructions are not observed, it may result in personal injury!



Caution

If these safety instructions are not observed, it may result in malfunction or damage to the equipment!

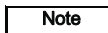

Note

Notes or instructions that make the job easier and ensure safe operation.

3. General

The Grundfos CME-Plus® system is for the pumping of clean, thin and non-explosive liquids, not containing solid particles or fibers that may attack the pump mechanically or chemically.

This manual describes the installation and operation of the Grundfos CME-Plus® Kit Assembly.

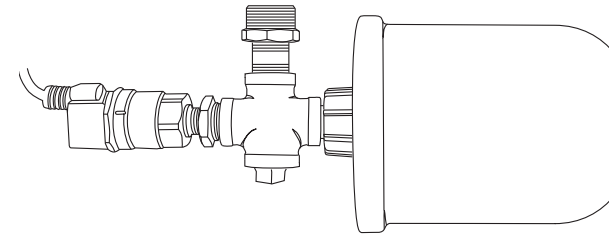

TM05 0651 1311

Fig. 1 Tank and transducer manifold assembly



Caution

If your pump is carrying the UL mark, official UL approval has been given for this pump for use with water only.

This product is Listed to applicable UL standards and requirements by Underwriters Laboratories Inc. for use with water only.

4. Shipment inspection

Examine the components carefully to make sure no damage has occurred to the pump during shipment. Care should be taken to ensure the components are NOT dropped or mishandled.

Check to see that these parts are included; see fig. 8 on p. 5.

1. Tank and sensor manifold
 - Diaphragm tank with O ring
 - Pressure transducer
 - 1/2" NPT plug
 - 1/2" NPT cross fitting
 - 1/2" to discharge size bushing
 - 1/4" to 1/2" bushing
 - 1/2" NPT nipple

2. Discharge assembly
 - 4" x discharge size pipe
 - Discharge size union
 - Discharge size nipple
 - Discharge size tee fitting
3. Suction assembly
 - Suction size pipe nipple
 - Suction size check valve
4. These installation and operating instructions

5. Kit assembly

5.1 Discharge assembly

1. Remove the CME pump from the box and place on workbench or work area.

Note

If you purchased a completed CME-Plus from the factory, a discharge pipe and union is already installed in the pump discharge and the tank/transducer manifold is already assembled. Attach the union assembly and then skip to section 5.3 Attach the tank.

2. Wrap 3 to 4 turns of Teflon® tape on all of the male threads of the discharge pipe fittings.
3. Thread the 4-inch by discharge sized pipe into the discharge of the pump. Thread the union, then the 2-inch by discharge sized pipe and tee onto the discharge pipe so that tee is on its side and the horizontal opening faces away from the terminal box.

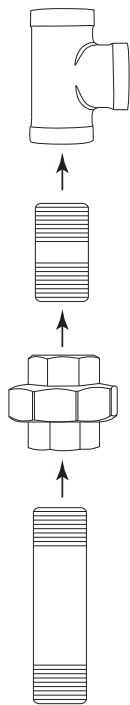

Fig. 2 Discharge assembly

5.2 Assemble the tank/transducer manifold

1. Wrap 3 to 4 turns of Teflon tape on all of the male threads of the pipe fittings and the pressure transducer. It is not necessary to wrap Teflon tape on the tank threads.
2. Thread the 1/2" NPT plug into a port on the cross fitting until hand tight. This port can be any of the four ports of the cross fitting. See fig. 3.

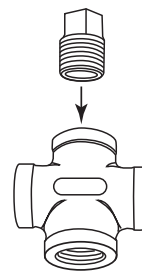

Fig. 3 Threading plug into cross fitting

3. Thread the 1/4" to 1/2" NPT bushing into one of the ports next to the plug from Step 2 in the cross fitting. This will be opposite of where the tank will be positioned. See fig. 4. Tighten until wrench tight.

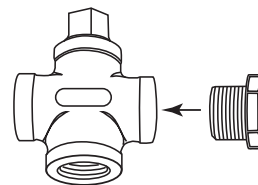

Fig. 4 Threading bushing into cross fitting next to plug

4. Thread the pressure transducer into the 1/4" NPT port of the bushing that you installed in Step 3 (this is before wiring the transducer to the terminal box); see fig. 5. Tighten until wrench tight.

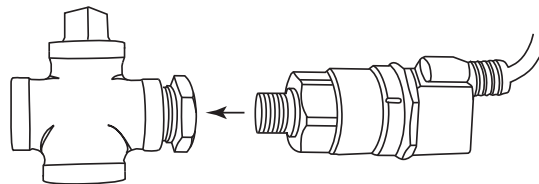

Fig. 5 Threading pressure transducer into bushing

5. Thread the 1/2" NPT pipe nipple into the port on the cross fitting opposite of the 1/2" NPT plug from Step 2. Tighten wrench tight; see fig. 6.
6. Thread the 1/2" to discharge size NPT bushing(s) onto 1/2" NPT pipe nipple. Tighten wrench tight; see fig. 6.

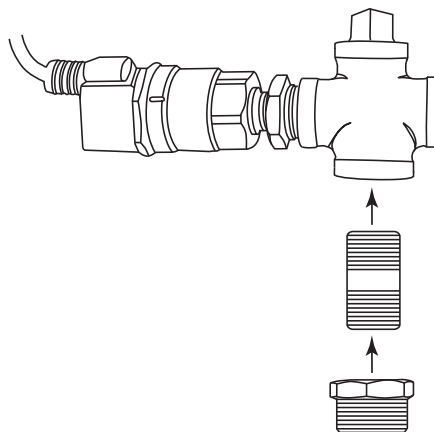

Fig. 6 Installing pipe nipple into cross fitting and bushing onto pipe nipple

TM05 0653 1311

TM05 0654 1311

TM05 0655 1311

TM05 0652 1311

TM05 0656 1311

7. Thread the tank/transducer manifold assembly to discharge tee as shown in fig. 7. Tighten wrench tight.
8. Tighten the cross fitting such that the transducer, plug and bushing(s) are positioned horizontally. Tighten wrench tight.

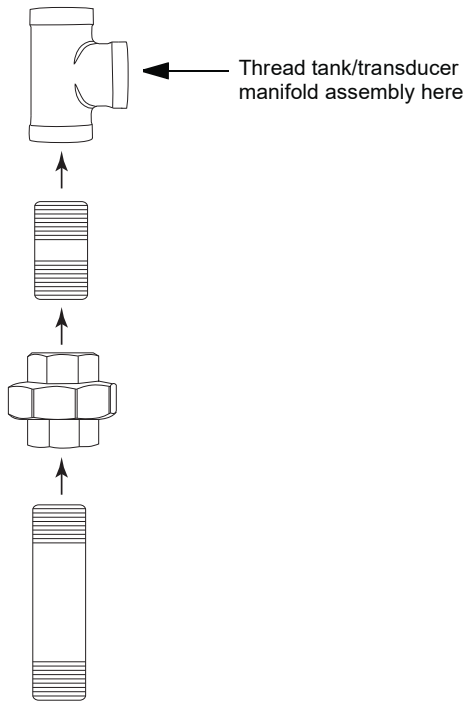

Fig. 7 Threading tank/transducer manifold assembly to discharge tee

TM05 0652 1311

5.3 Attach the tank

1. Remove the plastic protective cover from over the tank threads. Confirm the O-ring is in place and thread the tank into the final port in the 1/2" NPT cross fitting opposite the pressure transducer. Tank should now also be horizontal. Tighten until hand tight.
2. The tank is pre-charged from the factory to 50 psi (+/- 7 psi) and may need to be adjusted for optimum pump performance. Tank pre-charge pressure must be 0.7 x actual setpoint. 49 psi is the correct pre-charge setting for a 70 psi setpoint (70 x 0.7 = 49).

6. Install the pump

1. Install the pump according to the CM and CME Installation and Operating Instructions with these additional steps:
 - Wrap 3 to 4 turns of Teflon tape on the male threads of the suction size pipe nipple.
 - Thread the suction sized pipe nipple directly in the pump inlet fitting.
 - Thread the check valve onto the pipe nipple; tighten until wrench tight.

Note

If you purchased a complete CME-Plus from the factory, the pressure transducer and R100 settings are already installed.

2. Connect the main power cable and pressure transducer cable to the motor terminal box according to the CME Installation and Operating Instructions supplied with the pump.

6.1 Set the pump parameters

Using an R100 remote programmer, set the following parameters:

- SENSOR TYPE: As per the label on the transducer (typically 4-20 mA and range 0-87 psi (0-6 bar) or 0-145 psi (0-10 bar))
- STOP FUNCTION:Active
- CONTROL MODE:Controlled

6.2 Perform functional test

Note

Pump must be primed before functional test.

Start the pump and perform the following functional test including monitoring for leaks and watching for any obvious problems:

1. Reduce the setpoint to the second LED light from the bottom on the motor control panel by pressing the DOWN arrow as many times as necessary.
2. Slowly close the discharge line valve and observe that the motor reduces speed to compensate for the lower flow rate.
3. Fully close the discharge line valve to test the motor stop function. (The motor should stop within approximately 2 minutes if there are no leaks).

Note: The stop function may not operate properly, if the setpoint requires 90% to 100% of the motor maximum speed or if the diaphragm tank pre-pressure is not in the desired range.

4. Fully open the discharge line valve and observe that the pump starts again.



Warning

After setting your pump setpoint, be sure that you have not inadvertently set the pump to run on Max Curve, Min Curve or Stop. See the CRE, CRIE...CME Installation and Operating Instructions for more information.

5. The pump is ready for its normal operation now. Please see the CME Installation and Operating Instructions supplied with the pump for further instructions.

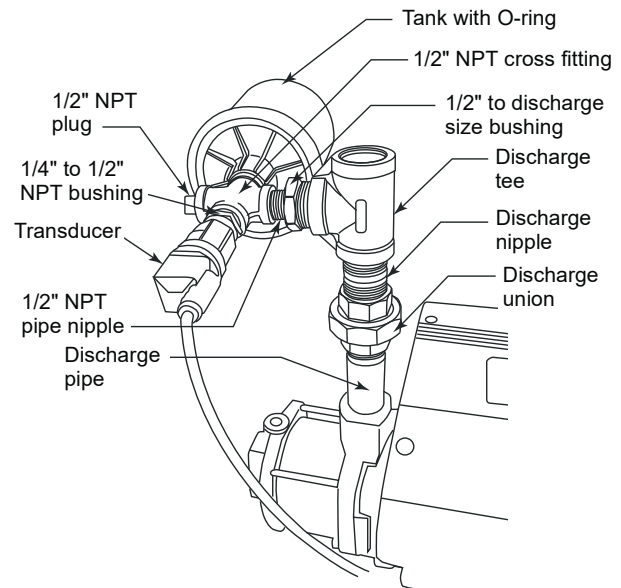

Fig. 8 Completed kit assembly

TM05 0659 1411

U.S.A.

GRUNDFOS Pumps Corporation
17100 West 118th Terrace
Olathe, Kansas 66061
Phone: +1-913-227-3400
Telefax: +1-913-227-3500

Canada

GRUNDFOS Canada Inc.
2941 Brighton Road
Oakville, Ontario
L6H 6C9
Phone: +1-905 829 9533
Telefax: +1-905 829 9512

México

Bombas GRUNDFOS de México S.A. de C.V.
Boulevard TLC No. 15
Parque Industrial Stiva
Aeropuerto
Apodaca, N.L.C.P. 66600
Phone: +52-81-8144 4000
Telefax: +52-81-8144 4010

L-CM-TL-004 0411

93025158 0411	US
ECM: 1374201	

© 2011 Grundfos Pumps Corp.

The name Grundfos, the Grundfos logo, and the payoff Be-Think-Innovate are registered trademarks owned by Grundfos Management A/S or Grundfos A/S, Denmark. All rights reserved worldwide.