

CR, CRN 95-255

North America

Installation and operating instructions



CR, CRN 95-255

English (US)

Installation and operating instructions 4

Français (CA)

Notice d'installation et de fonctionnement. 32

Español (MX)

Instrucciones de instalación y operación 62

Appendix A. **92**

English (US) Installation and operating instructions

Original installation and operating instructions	11.4	The motor-protective circuit breaker has not tripped, but the pump does not run.	28
Table of contents	11.5	The pump performance is not constant	28
1. Limited warranty	4	11.6 The pump runs, but gives no water	28
2. General information	5	11.7 The pump runs backwards when switched off	28
2.1 Hazard statements	5	11.8 Leakage in the shaft seal	28
2.2 Notes	5	11.9 Noise	29
2.3 Safety information for the motor	5	12. Technical data	30
3. Product introduction	6	12.1 Operating conditions	30
3.1 Applications	6	12.2 Electrical data	31
3.2 Intended use	6	12.3 Dimensions and weights	31
3.3 Identification	7	13. Disposing of the product	31
3.4 Type key	7		
4. Receiving the product	9	1. Limited warranty	
4.1 Transporting the product	9	Products manufactured by Grundfos Pumps Corporation (Grundfos) are warranted to the original user only to be free of defects in material and workmanship for a period of 24 months from date of installation, but not more than 30 months from date of manufacture. Grundfos' liability under this warranty shall be limited to repairing or replacing at Grundfos' option, without charge, F.O.B. Grundfos' factory or authorized service station, any product of Grundfos manufacture. Grundfos will not be liable for any costs of removal, installation, transportation, or any other charges that may arise in connection with a warranty claim. Products which are sold, but not manufactured by Grundfos, are subject to the warranty provided by the manufacturer of said products and not by Grundfos' warranty. Grundfos will not be liable for damage or wear to products caused by abnormal operating conditions, accident, abuse, misuse, unauthorized alteration or repair, or if the product was not installed in accordance with Grundfos' printed installation and operating instructions and accepted codes of good practice. The warranty does not cover normal wear and tear. To obtain service under this warranty, the defective product must be returned to the distributor or dealer of Grundfos' products from which it was purchased together with proof of purchase and installation date, failure date and supporting installation data. Unless otherwise provided, the distributor or dealer will contact Grundfos or an authorized service station for instructions. Any defective product to be returned to Grundfos or a service station must be sent freight prepaid; documentation supporting the warranty claim and/or a Return Material Authorization must be included if so instructed. Grundfos will not be liable for any incidental or consequential damages, losses, or expenses arising from installation, use, or any other causes. There are no express or implied warranties, including merchantability or fitness for a particular purpose, which extend beyond those warranties described or referred to above. Some	
4.2 Unpacking the product	9		
4.3 Inspecting the product	9		
4.4 Lifting the product	9		
5. Mechanical installation	13		
5.1 Drive-end motor bearing	14		
5.2 CRN 95, 125, 155 high-pressure range	14		
5.3 Motors for Variable Frequency Drive (VFD)	14		
5.4 Installation guidelines	14		
5.5 Foundation	16		
5.6 Vibration dampening	17		
5.7 Outdoor installation	17		
5.8 Tightening torques	18		
5.9 Flange forces and torques	19		
6. Electrical connection	20		
6.1 Maximum absorbed current	20		
7. Starting up the product	21		
7.1 Startup procedure	21		
7.2 Shaft seal run-in	22		
7.3 Operating the product	22		
8. Servicing the product	23		
8.1 Contaminated pumps	24		
8.2 Service documentation	24		
8.3 Maintaining the product	24		
9. Taking the product out of operation	25		
9.1 Taking the product permanently out of operation	25		
10. Storing the product	26		
10.1 Frost protection	26		
11. Fault finding the product	27		
11.1 The motor does not run when started	27		
11.2 The motor-protective circuit breaker trips immediately when the power supply is switched on	27		
11.3 The motor-protective circuit breaker trips occasionally	28		

jurisdictions do not allow the exclusion or limitation of incidental or consequential damages and some jurisdictions do not allow limitations on how long implied warranties may last. Therefore, the above limitations or exclusions may not apply to you. This warranty gives you specific legal rights and you may also have other rights which vary from jurisdiction to jurisdiction. Products which are repaired or replaced by Grundfos or authorized service center under the provisions of these limited warranty terms will continue to be covered by Grundfos warranty only through the remainder of the original warranty period set forth by the original purchase date.

2. General information



Read this document before you install the product. Installation and operation must comply with local regulations and accepted codes of good practice.

2.1 Hazard statements

The symbols and hazard statements below may appear in Grundfos installation and operating instructions, safety instructions and service instructions.



DANGER

Indicates a hazardous situation which, if not avoided, will result in death or serious personal injury.



WARNING

Indicates a hazardous situation which, if not avoided, could result in death or serious personal injury.



CAUTION

Indicates a hazardous situation which, if not avoided, could result in minor or moderate personal injury.

The hazard statements are structured in the following way:



SIGNAL WORD

Description of the hazard

Consequence of ignoring the warning

- Action to avoid the hazard.

2.2 Notes

The symbols and notes below may appear in Grundfos installation and operating instructions, safety instructions and service instructions.



Observe these instructions for explosion-proof products.



A blue or gray circle with a white graphical symbol indicates that an action must be taken.



A red or gray circle with a diagonal bar, possibly with a black graphical symbol, indicates that an action must not be taken or must be stopped.



If these instructions are not observed, it may result in malfunction or damage to the equipment.



Tips and advice that make the work easier.

2.3 Safety information for the motor



Read the safety information specific for the motor in the instructions for the motor which are supplied with the pump.

3. Product introduction

These installation and operating instructions describe Grundfos CR, CRN 95-255 pumps fitted with 60 Hz NEMA motors.

3.1 Applications

CR, CRN pumps are suitable for industrial applications such as the following:

- water supply
- cooling
- heating
- pressure boosting
- water treatment
- liquid transfer of cold or hot clean liquids.

3.2 Intended use

Only use the CR, CRN pumps according to the specifications stated in these installation and operating instructions.

3.2.1 Pumped liquids

DANGER

Fire and explosion

Death or serious personal injury

- Do not use the pump for flammable, combustible or explosive liquids.



WARNING

Chemical attack and leakage

Death or serious personal injury

- Do not use the pump for liquids which can attack the pump materials chemically.
- Contact Grundfos if in doubt.



WARNING

Corrosive liquids

Death or serious personal injury

- Wear personal protective equipment.



WARNING

Toxic liquids

Death or serious personal injury

- Wear personal protective equipment.



CAUTION

Hot or cold liquid

Minor or moderate personal injury

- Wear personal protective equipment.



CR, CRN pumps are suitable for pumping thin, clean, non-flammable, non-combustible or non-explosive liquids, not containing solid particles or fibers.

When pumping liquids with a density and/or viscosity higher than that of water, use motors with correspondingly higher outputs, if required.

Whether a pump is suitable for a particular liquid depends on a number of factors of which the most important are chloride content, pH value, temperature, content of chemicals and oils.

Please consult Grundfos for information about which pump types are suitable for a specific liquid.

3.3 Identification

3.3.1 Nameplate

The information on the pump nameplate is described below.

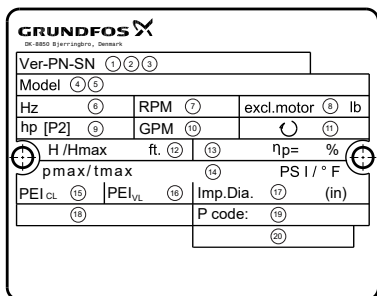

TM075722

Example of a nameplate

Pos.	Description
1	Version
2	Product number
3	Serial number
4	Model
5	Type designation
6	Frequency
7	Rated speed
8	Weight excluding motor
9	Motor-rated power output
10	Rated flow rate
11	Direction of rotation CCW: Counterclockwise CW: Clockwise
12	Head at rated flow rate / Maximum head
13	Hydraulic efficiency at rated flow rate
14	Maximum system pressure / Maximum liquid temperature. Note that this field may have two sets of data.
15	Pump Energy Index, constant load
16	Pump Energy Index, variable load
17	Impeller diameter
18	External reference (Other Equipment Manufacturer number)
19	Production code
20	Country of origin
21	Approval marks

3.4 Type key

Example

CRE 95-1-1 A-G-A-E-HQQE-N-C-B

Code	Explanation
CR	Type range: CR, CRI, CRN, CRT
E	Pump with integrated frequency converter
95	Flow rate (nominal, 50 Hz) [m ³ /h]
1	Number of impellers
1	Number of reduced-diameter impellers
A	Code for pump version
G	Code for pipe connection
A	Code for materials
E	Code for rubber parts
	Code for shaft seal:
H	• Shaft seal type designation
Q	• Seal face material (rotating seal face)
Q	• Seal face material (stationary seal face)
E	• Secondary seal material (rubber parts)
N	Code for motor: P2 [HP (kW)]
C	Code for motor: phase and voltage [V]
B	Code for motor: speed variant [rpm]

3.4.1 Key to codes

Code	Description
Pump version	
A	Basic version
B	Oversize motor
C	CR compact
D	Pump with pressure intensifier
E	Pump with certificate
F	Pump for high temperatures (with air-cooled top)
G	E-pump without operating panel
H	Horizontal version
I	Different pressure rating
J	E-pump with a different maximum speed
K	Pump with low NPSH
L	Pump including Grundfos CUE and certificate

Code	Description
M	Magnetic drive
N	With sensor
O	Cleaned and dried
P	Undersize motor
Q	High-pressure pump with high-speed MGE motor
R	Belt-driven pump
S	High-pressure pump
T	Thrust handling device
U	ATEX-approved pump
V	Cascade function
W	Deep-well pump with ejector
X	Special version
6	Special version with NSF 61/372 approval
Y	Electropolished
Z	Pumps with bearing flange

Pipe connection

A	Oval flange
B	NPT thread
CA	FlexiClamp
CX	TriClamp
F	DIN flange
FC	DIN 11853-2 flange (collar flange)
FE	EN 1092-1, type E
G	ANSI flange
J	JIS flange
N	Changed diameter of ports
P	PJE coupling (Victaulic type)
X	Special version

Materials

A	Basic version
C	Carbon-free pump
D	Carbon-graphite-filled PTFE (bearings)/tungsten carbide
E	Pickled and passivated (Only Japan)
H	Flanges and base plate EN 1.4408
K	Bronze (bearings)/tungsten carbide
L	Motor stool, base plate and flanges EN 1.4408
M	Motor stool, base plate, coupling and flanges EN 1.4408 and coupling guards in cobber. Bolts, nuts and spacing pipes EN 1.4401 or higher grade

Code	Description
N	Flanges EN 1.4408
P	PEEK neck ring
Q	Silicon carbide/silicon carbide bearing in pump and silicon carbide/silicon carbide seal faces in thrust handling device
R	Silicon carbide/silicon carbide bearing
S	PTFE neck rings
T	Base plate EN 1.4408
U	Silicon carbide/silicon carbide bearing in pump and silicon carbide/tungsten carbide seal faces in thrust handling device
W	Tungsten carbide/tungsten carbide
X	Special version

Rubber parts in pump

E	EPDM
F	FXM (Fluoraz [®])
K	FFKM (Kalrez [®])
N	CR (Neoprene)
V	FKM (Viton [®])

Shaft seal type designation

A	O-ring seal with fixed driver
H	Balanced cartridge seal with O-ring
O	Double seal, back-to-back
P	Double seal, tandem
X	Special version

Seal face material (rotating and stationary seal face)

B	Carbon, synthetic resin-impregnated
U	Cemented tungsten carbide
Q	Silicon carbide
X	Other ceramics

Secondary seal material (rubber parts)

E	EPDM
F	FXM (Fluoraz [®])
K	FFKM (Kalrez [®])
V	FKM (Viton [®])

3.4.1.1 Codes for motor

Code	Description
P2 [HP (kW)]	
C	0.33 (0.25)
D	0.5 (0.37)
E	0.75 (0.55)
F	1 (0.75)
G	1.5 (1.1)
H	2 (1.5)
I	3 (2.2)
K	5 (4)
L	7.5 (5.5)
M	10 (7.5)
N	15 (11)
O	20 (15)
P	25 (18.5)
Q	30 (22)
R	40 (30)
S	50 (37)
T	60 (45)
U	75 (55)
V	100 (75)
W	120 (90)
1	150 (110)
2	175 (132)
3	215 (160)
4	270 (200)
5	335 (250)
Phase and voltage (V)	
A	1 x 200-240 V
B	3 x 200-240 V
C	3 x 440-480 V
D	3 x 380-500 V
X	Not defined
Speed variant (rpm)	
A	1450-2000
B	2900-4000
C	4000-5900
2	2-pole
4	4-pole

4. Receiving the product

4.1 Transporting the product

WARNING

Falling objects

Death or serious personal injury



- Keep the product in a stable and fixed position during transportation.
- Wear personal protective equipment.

4.2 Unpacking the product

WARNING

Falling objects

Death or serious personal injury



- Keep the product in a stable position during unpacking.
- Wear personal protective equipment.

4.3 Inspecting the product

Before you install the product, do the following:

1. Check that the product is as ordered.
2. Check that no visible parts have been damaged.

If parts are damaged or missing, contact your local Grundfos sales company.

4.4 Lifting the product

WARNING

Falling objects

Death or serious personal injury



- Do not use the motor eyebolts to lift the entire pump if the pump is fitted with a motor of another make than Grundfos ML, MLE and MG, MGE.
- Follow the lifting instructions.
- Use lifting equipment which is approved for the weight of the product.
- Persons must keep a safe distance to the product during lifting operations.
- Wear personal protective equipment.

The following sections describe various lifting situations and the lifting instructions which must be followed in order to obtain safe lifting of the product:

- Position of lifting brackets: See the section on position of lifting brackets.

- Lifting the motor with or without the motor stool: See the section on lifting the motor off the pump.
- Horizontal lift: See the section on lifting the product in horizontal position.
- Raising or laying down the product: See the section on raising or laying down the product.
- Vertical lift: See the section on lifting the product in vertical position.
- Lifting of CRE pumps: See the section on lifting of pumps fitted with MLE and MGE motors.

Related information

4.4.1 Position of lifting brackets

4.4.2 Lifting the motor off the pump

4.4.3 Lifting of pumps fitted with MLE and MGE motors

4.4.4 Lifting the product in horizontal position

4.4.5 Raising or laying down the product

4.4.6 Lifting the product in vertical position

4.4.1 Position of lifting brackets

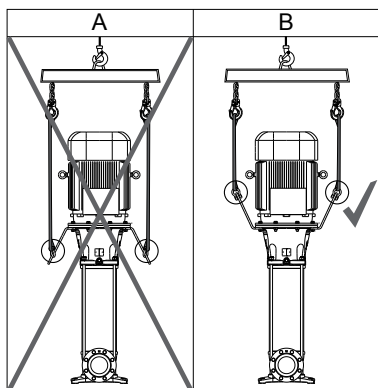

Position of lifting brackets

- | | |
|----|---|
| A: | Incorrect position of lifting brackets. |
| B: | Correct position of lifting brackets. |

4.4.2 Lifting the motor off the pump

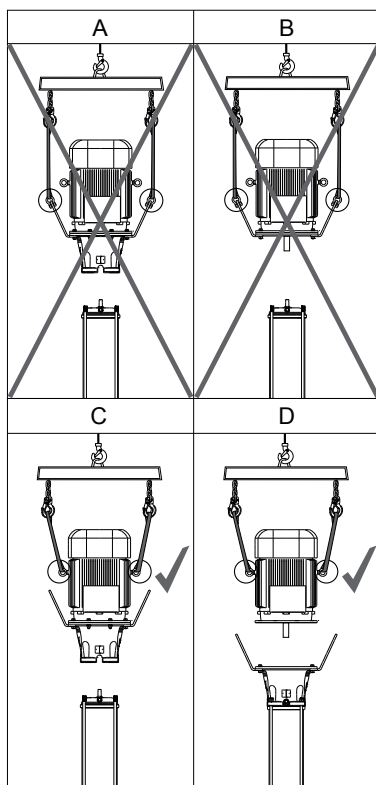

Lifting the motor

- | | |
|----|---|
| A: | Incorrect lifting of motor with motor stool. |
| B: | Incorrect lifting of motor without motor stool. |
| C: | Correct lifting of motor with motor stool. |
| D: | Correct lifting of motor without motor stool. |

4.4.3 Lifting of pumps fitted with MLE and MGE motors



When lifting a pump fitted with a motor that contains an integrated frequency converter, make sure that the terminal box does not come into contact with the lifting equipment.

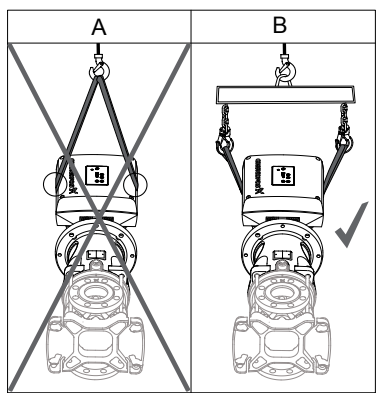

TM072290

Lifting of pumps fitted with MLE and MGE motors

- A: Incorrect lifting of pump with MLE motor.
- B: Correct lifting of pump with MLE motor.

4.4.4 Lifting the product in horizontal position

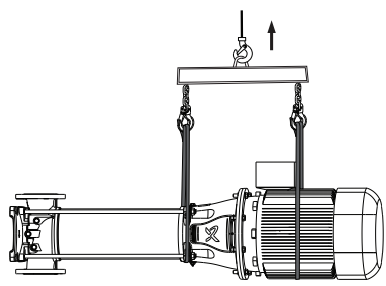

TM068773

Horizontal lift of pumps with 7.5 HP (5.5 kW) Grundfos ML, MLE and MG, MGE motors*

* See also the section on lifting of pumps fitted with MLE and MGE motors.

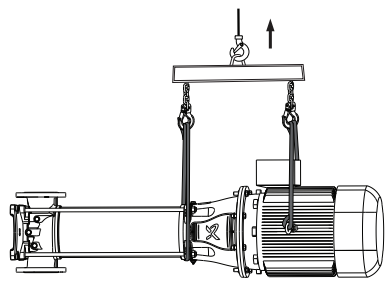

TM068774

Horizontal lift of pumps with 10-30 HP (7.5 - 22 kW) Grundfos ML, MLE and MG, MGE motors*

* See also the section on lifting of pumps fitted with MLE and MGE motors.

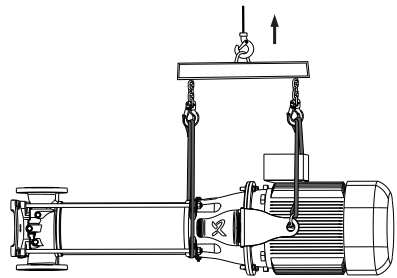

TM068627

Horizontal lift of pumps with 7.5 - 250 HP (5.5 - 200 kW) motors of other makes than Grundfos ML, MLE and MG, MGE motors

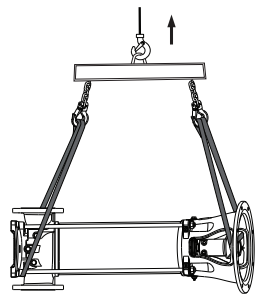

TM068775

Horizontal lift of pumps without a motor

Related information

[4.4.3 Lifting of pumps fitted with MLE and MGE motors](#)

4.4.5 Raising or laying down the product

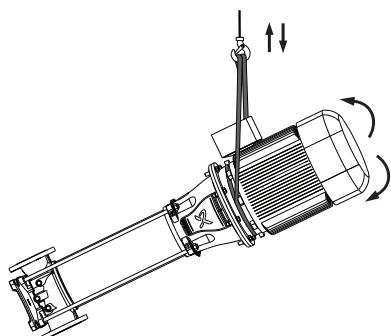

TM068744

Raising or laying down pumps with 7.5 HP (5.5 kW) Grundfos ML, MLE and MG, MGE motors*

* See also the section on lifting of pumps fitted with MLE and MGE motors.

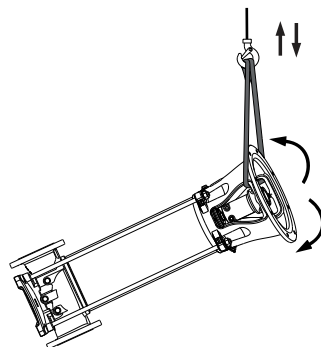

TM068745

Raising or laying down pumps without a motor

Related information

[4.4.3 Lifting of pumps fitted with MLE and MGE motors](#)

4.4.6 Lifting the product in vertical position

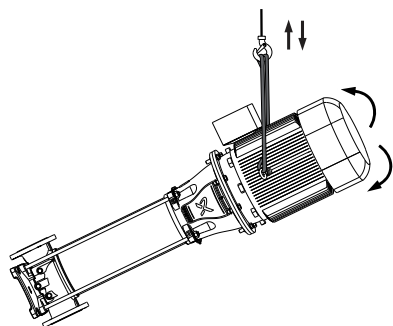

TM068743

Raising or laying down pumps with 10-30 HP (7.5 - 22 kW) Grundfos ML, MLE and MG, MGE motors*

* See also the section on lifting of pumps fitted with MLE and MGE motors.

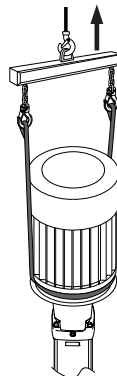

TM068597

Vertical lift of pumps with 7.5 HP (5.5 kW) Grundfos ML, MLE and MG, MGE motors

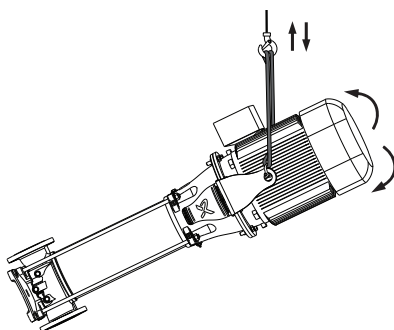

TM068742

Raising or laying down pumps with 7.5 - 250 HP (5.5 - 200 kW) motors of other makes than Grundfos ML, MLE and MG, MGE motors

5. Mechanical installation

DANGER

Falling objects

Death or serious personal injury

- Fasten the pump securely to a solid and even foundation according to the specifications stated in the installation and operating instructions.



WARNING

Contamination when pumping drinking water

Death or serious personal injury

- Before the pump is used for supplying drinking water, flush the pump thoroughly with clean water.
- Do not use the pump for drinking water if the internal parts have been in contact with particles or substances not suitable for water intended for human consumption.



WARNING

Falling objects

Death or serious personal injury

- Do not use the motor eyebolts to lift the entire pump if the pump is fitted with a motor of another make than Grundfos ML, MLE and MG, MGE.
- Follow the lifting instructions.
- Use lifting equipment which is approved for the weight of the product.
- Persons must keep a safe distance to the product during lifting operations.
- Wear personal protective equipment.

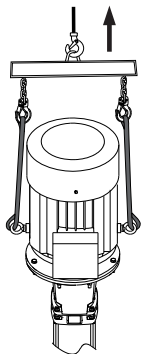

TM068598

Vertical lift of pumps with 10-30 HP (7.5 - 22 kW) Grundfos ML, MLE and MG, MGE motors

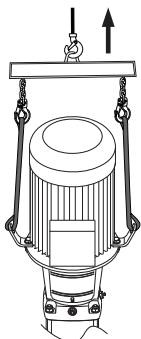

TM068599

Vertical lift of pumps with 7.5 - 250 HP (5.5 - 200 KW) motors of other makes than Grundfos ML, MLE and MG, MGE motors

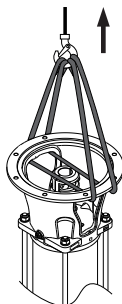

TM068162

Vertical lift of pumps without a motor

For lifting instructions, see the section on lifting the product.

Related information

[4.4 Lifting the product](#)

5.1 Drive-end motor bearing

Make sure to use the correct type of drive-end (DE) motor bearing for the bare-shaft pump. Please check the specific pump range and pump version stated on the nameplate and select the corresponding DE bearing.

Pump version ¹⁾	DE bearing CR 1-64 pump range		DE bearing CR 95-255 pump range	
	Deep-groove ball bearing (62/63xx)	Angular contact bearing (73xx)	Deep-groove ball bearing (62/63xx)	Angular contact bearing (73xx)
A Standard pump	0.33 - 10 HP	15-60 HP	100-300 HP	15-75 HP
T Pump with thrust handling device (THD) ²⁾	-	-	-	Not allowed
Z Pump with bearing flange ²⁾	0.33 - 60 HP	Not allowed	15-300 HP	Not allowed

1) Refer to the codes for pump version in the section on the type key.

2) Factory product variants (FPV).

Related information

3.4 Type key

5.2 CRN 95, 125, 155 high-pressure range



The pump sizes listed below are only to be used with soft starter or frequency converter.

CRN 95-6-3	CRN 125-7	CRN 155-5
CRN 95-6	CRN 125-8-2	CRN 155-6-2
CRN 95-7-2	CRN 125-8	CRN 155-6
CRN 95-7	CRN 125-9-3	CRN 155-7-2
CRN 95-8-2		CRN 155-7
CRN 95-8		CRN 155-8-3

5.3 Motors for Variable Frequency Drive (VFD)

To avoid bearing current when operating the pump with VFD, Grundfos recommends using an isolated bearing system for the following motor sizes:



- 2-pole motors: ≥ 60 HP (45 kW)
- 4-pole motors: ≥ 50 HP (37 kW)



Some installations may require protection at lower motor power due to either insufficient grounding, liquid influencing the grounding of the motor, or the combination of motor brand and frequency converter.

5.4 Installation guidelines

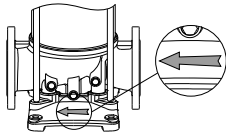
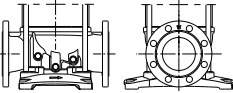
The pump must be secured to a horizontal, plane and solid foundation with bolts through the holes in the base plate. When installing the pump, be aware of the information below in order to avoid damaging the pump.

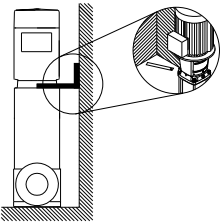
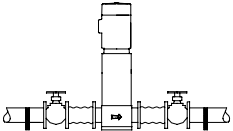
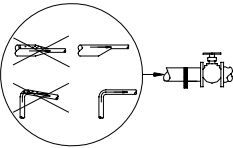
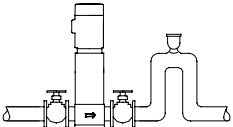
Illustration	Information
<p>1</p>  <p>TM069134</p>	<p>Arrows on the pump base plate show the direction of flow of liquid through the pump.</p>
<p>2</p>  <p>TM069156</p>	<p>These dimensions are stated in the appendix:</p> <ul style="list-style-type: none"> • port-to-port lengths • dimensions of the base plate • pipe connections • diameter and position of anchor bolts.
<p>3</p>  <p>TM070783</p>	<p>The pump can be installed vertically and horizontally. If you wish to install a pump horizontally, it must be ordered with support brackets fitted from factory and a foot-mounted motor.</p>
<p>3a</p>  <p>TM057705</p>	<p>Additional support. As the center of gravity of the pump is relatively high, we recommend that pumps installed on ships, in areas with risk of earthquake or in systems which can be moved, are equipped with an additional support bracket. You can fit the bracket from the motor stool to the bulkhead of the ship, a rigid wall in a building or to a rigid part.</p>
<p>4</p>  <p>TM020116</p>	<p>To minimize possible noise from the pump, we recommend that you fit expansion joints on either side of the pump. Build a foundation and carry out mechanical installation as described in the section on foundation. Fit isolating valves on either side of the pump to avoid draining the system if the pump needs to be removed for cleaning, repair or replacement. Always protect the pump against backflow by means of a check valve.</p>
<p>5</p>  <p>TM020114</p>	<p>Install the pipes so that air pockets do not occur.</p>
<p>6</p>  <p>TM020115</p>	<p>Fit a vacuum valve close to the pump if the installation has one of these characteristics:</p> <ul style="list-style-type: none"> • The outlet pipe slopes downwards away from the pump. • There is a risk of siphon effect. • Protection against backflow of unclean liquids is needed.

Related information

5.5 Foundation

5.5 Foundation

WARNING

Falling objects

Death or serious personal injury

- Keep the product in a stable and fixed position before installing it.
- Make sure that the foundation is suitable for the weight of the product.



We recommend that you install the pump on a concrete foundation which is heavy enough to provide permanent and rigid support for the entire pump. The foundation must be capable of absorbing any vibration, normal strain or shock. The concrete foundation must have an absolutely level and even surface.

1. Determine the size of the concrete foundation for vertical or horizontal mounting of the pump. Follow the instructions below.
2. Place the pump on the foundation.
3. Fasten the pump with anchor bolts according to the instructions below.
4. Make sure that the base plate is supported on the whole area.

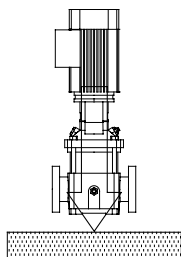

Correct installation

Length and width of the concrete foundation

The recommended length (L_f) and width (W_f) of the foundation for vertical and horizontal mounting are shown in the figures below.

- The length and width of the foundation must always be 7.87 inches (200 mm) larger than the length and width of the pump.
- Pumps with a motor size below or equal to 40 HP (30 kW): The length and width of the foundation must be 7.87 inches (200 mm) larger than the base plate.
- Pumps with a motor size equal to or above 50 HP (37 kW): The length and width of the foundation must always be 4.9 x 4.9 ft (1.5 x 1.5 m).

TM040342

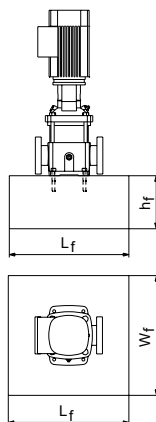

Foundation, vertical mounting

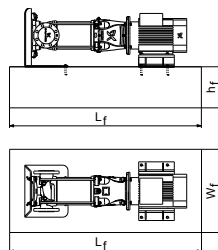

Foundation, horizontal mounting

Minimum height of the concrete foundation

- Calculate the minimum height of the foundation (h_f) using below equation.
- The mass of the foundation must be at least 1.5 times the total mass of the pump (M_p).
- Use a foundation with a mass up to 5 times that of the pump in installations where noiseless operation is particularly important.

$$h_f = \frac{M_p \times 1.5}{L_f \times W_f \times \delta_c}$$

The density (δ_c) of concrete is usually taken as 137.3 lb/ft³ (2200 kg/m³).

TM068985

TM070574

Anchor bolts

The foundation must be provided with anchor bolts for fixing the base plate.

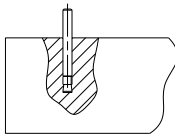

Anchor bolt in foundation

When the anchor bolts are in position, place the pump on the foundation. Then align the base plate using shims, if necessary, so that it is completely horizontal. See the figure below.

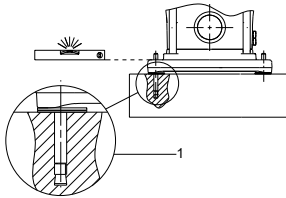

Alignment with shims (pos. 1)

5.6 Vibration dampening

Elimination of noise and vibrations is best achieved by means of a concrete foundation, vibration dampers and expansion joints.

If you use vibration dampers, install them under the foundation. For pumps with a motor size below or equal to 40 HP (30 kW), you can use vibration dampers.

For pumps with a motor size equal to or above 50 HP (37 kW), you can use a Sylomer® plate.

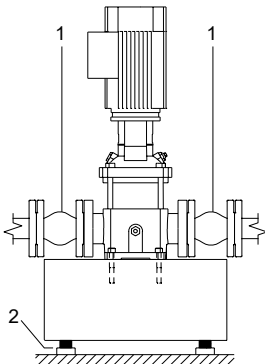

Pump on vibration dampers

Pos.	Description
1	Expansion joints
2	Vibration dampers

TM034589

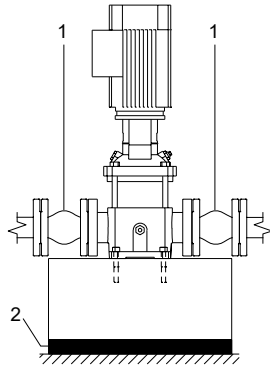

TM068000

Pump on Sylomer® plate

Pos.	Description
1	Expansion joints
2	Sylomer® plate

TM040362

5.7 Outdoor installation

When the pump is installed outdoors, we recommend that you provide the motor with a rain cover. We also recommend that you open one of the drain holes in the motor flange.

TM067999

5.8 Tightening torques

WARNING

Flange gasket blowout

Death or serious personal injury

- Tighten flange bolts according to the specified torque values.

WARNING

Falling objects

Death or serious personal injury

- Tighten the base plate anchor bolts according to the specified torque values.

The tables show the recommended torques for base plate anchor bolts and flange bolts.

The bolt quality must be minimum class 5.8 except for CR, CRN 95 with optional small base plate which must be minimum class 8.8.

Base plate anchor bolts

UNC bolts:

CR, CRN	Base plate anchor bolts		
	Bolt size	Torque	
	[Ø inch]	[lbf-ft]	[Nm]
95 with optional small base plate	UNC 1/2-13 (Ø9/16" free hole)	52	71
	UNC 5/8-11 (Ø11/16" free hole)	74	100
125-155	UNC 3/4-10 (Ø7/8" free hole)	66 ¹⁾	90 ¹⁾
	UNC 7/8-9 (Ø1" free hole)	140 ²⁾	190 ²⁾
185-255	UNC 7/8-9 (Ø1" free hole)	100	136

1) Applies for pumps fitted with motors up to and including 75 HP.

2) Applies for pumps fitted with motors of 100 HP and up.

Metric bolts:

CR, CRN	Base plate anchor bolts		
	Bolt size	Torque	
	[Ø mm]	[Nm]	[lbf-ft]
95 with optional small base plate	M12 (Ø14 free hole)	65	48
	M16 (Ø18 free hole)	100	75
125-155	M20 (Ø22 free hole)	90 ¹⁾	66 ¹⁾
	M24 (Ø26 free hole)	190 ²⁾	140 ²⁾
185-255	M24 (Ø26 free hole)	130	96

Flange bolts

UNC bolts and ANSI flanges:

CR, CRN	Flange bolts ANSI		
	Bolt size	Torque	
		[lbf-ft]	[Nm]
95	UNC 5/8-11	25	34
	UNC 3/4-10	60	81
125-155	UNC 3/4-10	60	81
	UNC 1-8	66	90
185-255	UNC 3/4-10	110	149
	UNC 7/8-9	185	251

Metric bolts and DIN/EN, JIS flanges:

CR, CRN	Flange bolts DIN/EN, JIS		
	Bolt size	Torque	
		[Nm]	[lbf-ft]
95	M16	30	22
	M20	90	66
125-155	M20	90	66
	M24	230	170
185-255	M20	90	66
	M24	230	170
	M27	300	222

5.9 Flange forces and torques

If not all loads reach the maximum permissible value stated in the tables below, one of these values may exceed the normal limit. Contact Grundfos for further information.

Y-direction: Inlet or outlet
 Z-direction: Direction of chamber stack
 X-direction: 90° from inlet or outlet

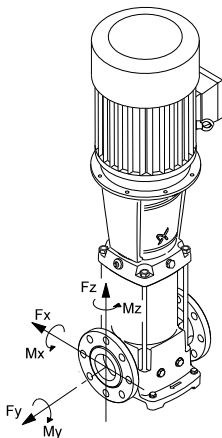

The following tables represent the values that apply according to the material quality.

Force limits for CR pumps

Flange	CR	Force, Y-direction [lbf (N)]	Force, Z-direction [lbf (N)]	Force, X-direction [lbf (N)]
4" ANSI (DN 100)	95	282 (1256)	228 (1013)	253 (1125)
6" ANSI (DN 150)	125, 155	422 (1875)	342 (1519)	380 (1688)
8" ANSI (DN 200)	185, 215, 255	465 (2513)	455 (2025)	506 (2250)

Force limits for CRN pumps

Flange	CRN	Force, Y-direction [lbf (N)]	Force, Z-direction [lbf (N)]	Force, X-direction [lbf (N)]
4" ANSI (DN 100)	95	565 (2513)	455 (2025)	506 (2250)
6" ANSI (DN 150)	125, 155	843 (3750)	683 (3038)	759 (3375)
8" ANSI (DN 200)	185, 215, 255	1130 (5025)	910 (4050)	1012 (4500)

Torque limits for CR pumps

Flange	CR	Torque, Y-direction [lbf (N)]	Torque, Z-direction [lbf (N)]	Torque, X-direction [lbf (N)]
4" ANSI (DN 100)	95	84 (375)	107 (475)	141 (625)
6" ANSI (DN 150)	125, 155	141 (625)	174 (775)	225 (1000)
8" ANSI (DN 200)	185, 215, 255	202 (900)	242 (1075)	309 (1375)

TMC40346

Torque limits for CRN pumps

Flange	CRN	Torque, Y-direction [lbf (N)]	Torque, Z-direction [lbf (N)]	Torque, X-direction [lbf (N)]
4" ANSI (DN 100)	95	169 (750)	214 (950)	281 (1250)
6" ANSI (DN 150)	125, 155	281 (1250)	349 (1550)	450 (2000)
8" ANSI (DN 200)	185, 215, 255	405 (1800)	483 (2150)	618 (2750)

6. Electrical connection



Follow the instructions for the motor when carrying out the electrical connections.

The electrical connection must be carried out by an authorized electrician in accordance with local regulations.

WARNING**Electric shock**

Death or serious personal injury

- Before starting any work on the product, make sure that the power supply has been switched off and that it cannot be accidentally switched on.
- Connect the pump to an external main switch close to the pump and to a motor-protective circuit breaker or a CUE frequency converter. Make sure you can lock the main switch in OFF position (isolated). Type and requirements as specified in EN 60204-1, 5.3.2.

**WARNING****Electric shock**

Death or serious personal injury

- Connect the pump to the same protective-earth (PE) potential as the motor if both motor bearings are of the insulated type such as ceramic bearings.



6.1 Maximum absorbed current



Some motors can absorb a maximum current which is larger than the full load current $I_{1/1}$ stated on the nameplate. See the table below.

Motor type according to the nameplate	Upper limit for absorbed current
Motors marked with both of the below for 60 Hz NEMA:	
<ul style="list-style-type: none"> • full load amps (full load current $I_{1/1}$) • SFA (service factor amps) 	SFA
Grundfos MG motors marked with both of the below for 60 Hz:	
<ul style="list-style-type: none"> • full load current $I_{1/1}$ • maximum current I_{max} 	I_{max}

7. Starting up the product



WARNING

Corrosive liquids

Death or serious personal injury

- Wear personal protective equipment.



WARNING

Toxic liquids

Death or serious personal injury

- Wear personal protective equipment.



CAUTION

Hot or cold liquid

Minor or moderate personal injury



- Wear personal protective equipment.
- Pay attention to the direction of the vent hole when you fill the pump with liquid and vent it.
- Make sure that no persons are hurt by the escaping liquid.



Fill the pump with liquid and vent it before you start the pump.



Pay attention to the direction of the vent hole during liquid filling and venting. Make sure that the escaping liquid does not cause damage to the motor or other components.

Vent valve, standard and an optional solution with hose connection

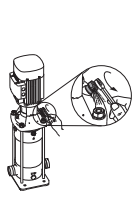

TM056098

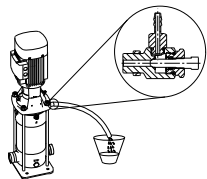

TM051160

7.1 Startup procedure

1. Close the isolating valve on the outlet side of the pump and open the isolating valve on the inlet side.

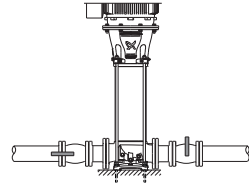

TM006682

2. Remove the priming plug from the pump head and slowly fill the pump with liquid. Replace the priming plug and tighten securely.

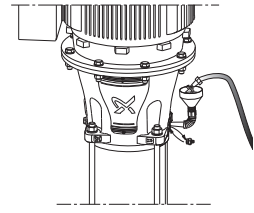

TM006683

3. See the correct direction of rotation of the pump on the motor fan cover.

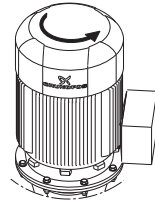

TM006684

4. Start the pump and check the direction of rotation.

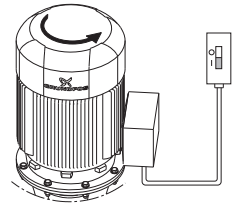

TM006685

5. Vent the pump by means of the vent valve in the pump head. At the same time, open the outlet isolating valve a little.

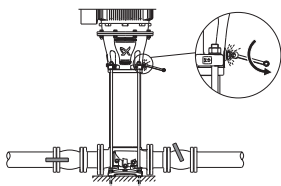

TM066886

6. Continue to vent the pump. At the same time, open the outlet isolating valve a little more.

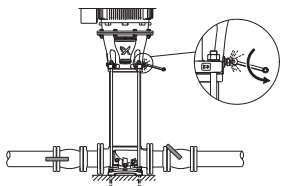

TM066887

7. Close the vent valve when a steady stream of liquid runs out of it.

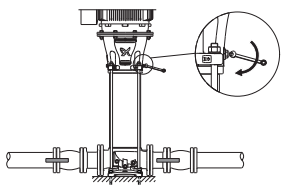

TM066888

8. Completely open the outlet isolating valve.

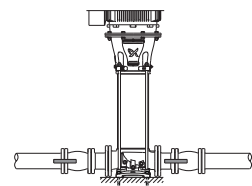

TM072337

7.2 Shaft seal run-in

WARNING

Corrosive liquids

Death or serious personal injury

- Wear personal protective equipment.



WARNING

Toxic liquids

Death or serious personal injury

- Wear personal protective equipment.



CAUTION

Hot or cold liquid

Minor or moderate personal injury

- Wear personal protective equipment.



Make sure that a leakage does not cause damage to the equipment.

The seal faces are lubricated by the pumped liquid, meaning that there may be a certain amount of leakage from the shaft seal.

When you start the pump for the first time, or when you install a new shaft seal, a certain run-in period is required before the leakage is reduced to an acceptable level. The time required for this depends on the operating conditions, that is every time the operating conditions change, a new run-in period will be started.

Under normal conditions, the leaking liquid will evaporate. As a result, no leakage will be detected.

7.3 Operating the product

For operating the product safely, observe the following hazard statements.

WARNING

Contamination when pumping drinking water

Death or serious personal injury

- Do not use the pump for drinking water if the internal parts have been in contact with particles or substances not suitable for water intended for human consumption.



WARNING

Airborne noise

Death or serious personal injury

- Wear personal protective equipment.



The sound pressure levels listed in the appendix relate to airborne noise emitted by pumps with motors fitted by Grundfos.

WARNING

Too high pressure and leakage

Death or serious personal injury

- Do not run the pump against a closed outlet valve.



WARNING**Intoxication if pumping toxic or corrosive liquids**

Death or serious personal injury

- Pumped liquid which is drained off or leaks from the pump must be collected for safe disposal.

**CAUTION****Hot or cold surface**

Minor or moderate personal injury



- Make sure that no one can accidentally come into contact with hot or cold surfaces.

8. Servicing the product**DANGER****Electric shock**

Death or serious personal injury



- Before starting any work on the product, make sure that the power supply has been switched off and that it cannot be accidentally switched on.

DANGER**Electric shock**

Death or serious personal injury



- Close the inlet and outlet valves to eliminate flow through the pump which can cause the pump to act as a turbine and consequently generate a current in the motor.

WARNING**Electric shock**

Death or serious personal injury



- Connect the pump to the same protective-earth (PE) potential as the motor if both motor bearings are of the insulated type such as ceramic bearings.

WARNING**Falling objects**

Death or serious personal injury



- Do not use the motor eyebolts to lift the entire pump if the pump is fitted with a motor of another make than Grundfos ML, MLE and MG, MGE.
- Follow the lifting instructions.
- Use lifting equipment which is approved for the weight of the product.
- Persons must keep a safe distance to the product during lifting operations.
- Wear personal protective equipment.

For lifting instructions, see the section on lifting the product.

WARNING**Falling objects**

Death or serious personal injury



- Keep the product in a stable and fixed position when working on it.

WARNING**Contamination when pumping drinking water**

Death or serious personal injury



- Before the pump is used for supplying drinking water, flush the pump thoroughly with clean water.
- Do not use the pump for drinking water if the internal parts have been in contact with particles or substances not suitable for water intended for human consumption.
- Always use original spare parts suitable for drinking water.

WARNING**Intoxication if pumping toxic or corrosive liquids**

Death or serious personal injury



- Pumped liquid which is drained off or leaks from the pump must be collected for safe disposal.

WARNING**Corrosive liquids**

Death or serious personal injury



- Wear personal protective equipment.



WARNING

Toxic liquids

Death or serious personal injury

- Wear personal protective equipment.



WARNING

Moving parts

Death or serious personal injury

- Install the coupling guards securely to the pump with the screws intended for this purpose.



CAUTION

Hot or cold liquid

Minor or moderate personal injury

- Wear personal protective equipment.



CAUTION

Hot or cold surface

Minor or moderate personal injury

- Make sure that no one can accidentally come into contact with hot or cold surfaces.



We recommend that you repair pumps with motors of 10 HP (7.5 kW) and up at the installation site. Necessary lifting equipment must be available.

Related information

[4.4 Lifting the product](#)

8.1 Contaminated pumps



CAUTION

Biological hazard

Minor or moderate personal injury

- Flush the pump thoroughly with water and rinse the pump parts in water after dismantling.

The product will be classified as contaminated if it has been used for a liquid which is injurious to health or toxic. If you request Grundfos to service the product, contact Grundfos with details about the pumped liquid before returning the product for service. Otherwise, Grundfos can refuse to accept the product for service.

Any application for service must include details about the pumped liquid.

Clean the product in the best possible way before you return it. Costs of returning the product are to be paid by the customer.

8.2 Service documentation

8.2.1 Pump

You can find detailed information about how to service your product in the service instructions which can be accessed via the QR code or link below:

Service instructions for CR, RN 95-255



<http://net.grundfos.com/qri/i/99233360>

Additional service documentation including service videos are available in Grundfos Product Center > <http://product-selection.grundfos.com/>.

8.2.2 Motor

Grundfos ML, MLE, MG and MGE motors

Service documentation is available in Grundfos Product Center > <http://product-selection.grundfos.com/>.

Motors of other makes

Contact the motor manufacturer.

8.3 Maintaining the product

DANGER

Electric shock

Death or serious personal injury



- Before starting any work on the product, make sure that the power supply has been switched off and that it cannot be accidentally switched on.

WARNING

Falling objects

Death or serious personal injury



- Do not use the motor eyebolts to lift the entire pump if the pump is fitted with a motor of another make than Grundfos ML, MLE and MG, MGE.
- Follow the lifting instructions.
- Use lifting equipment which is approved for the weight of the product.
- Persons must keep a safe distance to the product during lifting operations.
- Wear personal protective equipment.

For lifting instructions, see the section on lifting the product.

WARNING**Falling objects**

Death or serious personal injury

- Keep the product in a stable and fixed position when working on it.

**WARNING****Corrosive liquids**

Death or serious personal injury

- Wear personal protective equipment.

**WARNING****Toxic liquids**

Death or serious personal injury

- Wear personal protective equipment.

**CAUTION****Hot or cold liquid**

Minor or moderate personal injury

- Wear personal protective equipment.

**CAUTION****Hot or cold surface**

Minor or moderate personal injury

- Make sure that no one can accidentally come into contact with hot or cold surfaces.

**Related information**

[4.4 Lifting the product](#)

8.3.1 Pump

The pump bearings and the shaft seal are maintenance-free.

8.3.2 Motor

Carry out maintenance as described in the instructions for the motor which are supplied with the pump.

9. Taking the product out of operation**9.1 Taking the product permanently out of operation**

Observe the following if the pump is to be permanently taken out of operation and removed from the pipe system.

DANGER**Electric shock**

Death or serious personal injury

- Before starting any work on the product, make sure that the power supply has been switched off and that it cannot be accidentally switched on.

**WARNING****Falling objects**

Death or serious personal injury

- Do not use the motor eyebolts to lift the entire pump if the pump is fitted with a motor of another make than Grundfos ML, MLE and MG, MGE.
- Follow the lifting instructions.
- Use lifting equipment which is approved for the weight of the product.
- Persons must keep a safe distance to the product during lifting operations.
- Wear personal protective equipment.



For lifting instructions, see the section on lifting the product.

WARNING**Falling objects**

Death or serious personal injury

- Keep the product in a stable and fixed position when working on it.

**WARNING****Corrosive liquids**

Death or serious personal injury

- Wear personal protective equipment.

**WARNING****Toxic liquids**

Death or serious personal injury

- Wear personal protective equipment.

**CAUTION****Hot or cold liquid**

Minor or moderate personal injury

- Wear personal protective equipment.





CAUTION

Hot or cold surface

Minor or moderate personal injury



- Make sure that no one can accidentally come into contact with hot or cold surfaces.

Related information

[4.4 Lifting the product](#)

10. Storing the product

10.1 Frost protection

CAUTION

Hot or cold liquid

Minor or moderate personal injury



- Pay attention to the direction of the vent hole and drain plug when draining the pump. Make sure that the escaping liquid does not cause injury to persons.



- Wear personal protective equipment.



Pay attention to the direction of the vent hole and drain plug when draining the pump. Make sure that the escaping liquid does not cause damage to the motor or other components.

Drain pumps which are not being used during periods of frost to avoid damage.

To drain the pump loosen the vent screw in the pump head and remove all drain plugs from one side of the pump base.

Do not tighten the vent screw and replace the drain plug until the pump is to be used again.

11. Fault finding the product

DANGER

Electric shock

Death or serious personal injury



- Before starting any work on the product, make sure that the power supply has been switched off and that it cannot be accidentally switched on.

WARNING

Corrosive liquids

Death or serious personal injury



- Wear personal protective equipment.

WARNING

Toxic liquids

Death or serious personal injury



- Wear personal protective equipment.

WARNING

Falling objects

Death or serious personal injury



- Keep the product in a stable and fixed position when working on it.

CAUTION

Hot or cold liquid

Minor or moderate personal injury



- Wear personal protective equipment.

CAUTION

Hot or cold surface

Minor or moderate personal injury



- Make sure that no one can accidentally come into contact with hot or cold surfaces.

11.1 The motor does not run when started

Cause	Remedy
Supply failure.	Connect the power supply.
The fuses are blown.	Replace the fuses.
The motor-protective circuit breaker has tripped.	Reactivate the motor-protective circuit breaker.
The thermal protection has tripped.	Reactivate the thermal protection.
The main contacts in the motor-protective circuit breaker are not making contact or the coil is faulty.	Replace the contacts or the magnetic coil.
The control circuit is defective.	Repair the control circuit.
The motor is defective.	Replace the motor.

11.2 The motor-protective circuit breaker trips immediately when the power supply is switched on

Cause	Remedy
One fuse is blown or the automatic circuit breaker has tripped.	Replace the fuse or reset the circuit breaker.
The contacts in the motor-protective circuit breaker are faulty.	Replace the motor-protective circuit breaker contacts.
The cable connection is loose or faulty.	Fasten or replace the cable connection.
The motor winding is defective.	Replace the motor.
The pump is mechanically blocked.	Remove the mechanical blocking of the pump.
The motor-protective circuit breaker setting is too low.	Set the motor-protective circuit breaker correctly.

11.3 The motor-protective circuit breaker trips occasionally

Cause	Remedy
The motor-protective circuit breaker setting is too low.	Set the motor-protective circuit breaker correctly.
Low voltage at peak times.	Ensure a stable power supply.

11.4 The motor-protective circuit breaker has not tripped, but the pump does not run

Cause	Remedy
Supply failure.	Connect the power supply.
The fuses are blown.	Replace the fuses.
The thermal protection has tripped.	Reactivate the thermal protection.
The main contacts in the motor-protective circuit breaker are not making contact or the coil is faulty.	Replace the contacts or the magnetic coil.
The control circuit is defective.	Repair the control circuit.

11.5 The pump performance is not constant

Cause	Remedy
The pump inlet pressure is too low (cavitation).	Check the inlet conditions.
The inlet pipe or pump is partly blocked by impurities.	Clean the inlet pipe or pump.
The pump draws in air.	Check the inlet conditions.

11.6 The pump runs, but gives no water

Cause	Remedy
The inlet pipe or pump is blocked by impurities.	Clean the inlet pipe or pump.
The foot or check valve is blocked in closed position.	Repair the foot or check valve.
There is a leakage in the inlet pipe.	Repair the inlet pipe.
There is air in the inlet pipe or pump.	Check the inlet conditions.
The motor runs in the wrong direction of rotation.	Change the direction of rotation of the motor.

11.7 The pump runs backwards when switched off

Cause	Remedy
There is a leakage in the inlet pipe.	Repair the inlet pipe.
The foot or check valve is defective.	Repair the foot or check valve.

11.8 Leakage in the shaft seal

Cause	Remedy
The shaft seal is defective.	Replace the shaft seal.

11.9 Noise

Cause	Remedy
Cavitation.	Check the inlet conditions.
The pump does not rotate freely due to frictional resistance as a result of incorrect pump shaft position.	Adjust the pump shaft as described in the service documentation. See the section on service documentation.
Frequency converter operation.	See the instructions for the motor which are supplied with the pump.

12. Technical data

12.1 Operating conditions

12.1.1 Ambient temperature and altitude

See the instructions for the motor which are supplied with the pump.

12.1.2 Maximum system pressure and liquid temperature

The maximum permissible system pressure and liquid temperature are stated on the nameplate which is placed on the pump. For identification of the nameplate data, see the section on the nameplate.

12.1.3 Maximum permissible operating pressure and liquid temperature for the shaft seal

The operating range of a shaft seal depends on the operating pressure, the liquid temperature and the type of shaft seal.

The selection charts show which shaft seals are suitable at a given temperature and a given pressure.

See the figures below. The charts apply to clean water.

Ø22 shaft seals for 15-75 HP (11-55 kW)

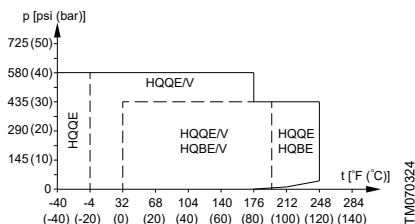

Maximum permissible operating pressure and liquid temperature for pumps with Ø22 shaft seal (≤ 75 HP (55 kW))

Ø28 and Ø36 shaft seals for 100-300 HP (75-224 kW)

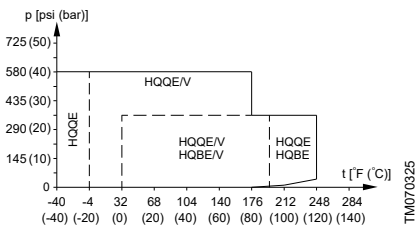

Maximum permissible operating pressure and liquid temperature for pumps with Ø28 and Ø36 shaft ends (100-300 HP (75-224 kW))

12.1.4 Minimum inlet pressure

We recommend that you calculate the inlet pressure "H" in these situations:

- The liquid temperature is high.
- The flow rate is significantly higher than the rated flow rate.
- Water is drawn from depths.
- Water is drawn through long pipes.
- Inlet conditions are poor.

To avoid cavitation, make sure that there is a minimum pressure on the inlet side of the pump.

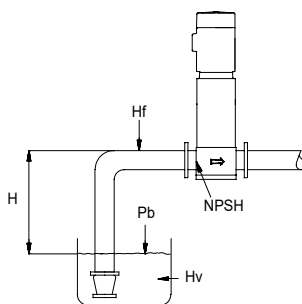

Schematic view of an open system with a CR pump

Calculate the maximum suction lift "H" in ft (m) head as follows:

$$H = P_b - NPSH - H_f - H_v \text{ (result in ft)}$$

$$(P_b \times 10.2 - NPSH - H_f - H_v \text{ (result in m)})$$

P_b = Barometric pressure in feet absolute (bar).

Barometric pressure can be set to 33.46 ft (1 bar).

In closed systems, P_b indicates the system pressure in ft (bar).

$NPSH$ = Net Positive Suction Head in ft (m) head, to be read from the NPSH curve in the appendix at the highest flow the pump will be delivering.

H_f = Friction loss in the inlet pipe in ft (m) head at the highest flow the pump will be delivering.

H_v = Vapor pressure in ft (m) head. See the appendix.

t_m = Liquid temperature.

If the calculated "H" is positive, the pump can operate at a suction lift of maximum "H" ft (m) head.

If the calculated "H" is negative, an inlet pressure of minimum "H" ft (m) head is required. There must be a pressure equal to the calculated "H" during operation.

Example with result in feet

$P_b = 33.46$ ft.

Pump type: CR 95.

Flow rate: 418 GPM.

NPSH (see the NPSH curve in the appendix):
11.48 ft head.

$H_f = 9.84$ ft head.

Liquid temperature: +140 °F.

H_v (see the appendix): 6.9 ft head.

$H = P_b - NPSH - H_f - H_v$ [ft head].

$H = 33.46 - 11.48 - 9.84 - 6.9 = 5.24$ ft. This means that the pump can operate at a suction lift of maximum 5.24 ft head.

Pressure in psi:

$H \times 0.433 \times$ specific gravity of pumped fluid

$5.24 \times 0.433 \times 1 = 2.27$ psi.

Example with result in meters

$P_b = 1$ bar

Pump type: CR 95

Flow rate: 95 m³/h

NPSH (see the NPSH curve in the appendix): 3.5 m head.

$H_f = 3.0$ m head.

Liquid temperature: +60 °C.

H_v (see the appendix): 2.1 m head.

$H = P_b \times 10.2 - NPSH - H_f - H_v$ [ft head].

$H = 1 \times 10.2 - 3.5 - 3.0 - 2.1 = 1.6$ m head.

This means that the pump can operate at a suction lift of maximum 1.6 m head.

Pressure in bar: $1.6 \times 0.0981 = 0.157$ bar.

Pressure in kPa: $1.6 \times 9.81 = 15.7$ kPa.

12.1.5 Maximum permissible inlet pressure

The table in the appendix states the maximum permissible inlet pressure for vertically mounted pumps. However, the actual inlet pressure + the maximum pump pressure at no flow must always be lower than the maximum permissible system pressure which is stated on the pump nameplate. For identification of the nameplate data, see the section on the nameplate.

The pumps are pressure-tested at a pressure of 1.5 times the maximum permissible system pressure.

12.1.6 Minimum flow rate**WARNING**

Too high pressure and leakage

Death or serious personal injury

- Do not run the pump against a closed outlet valve.

Due to the risk of overheating, do not use the pump at flows below the minimum flow rate.

The curves below show the minimum flow rate as a percentage of the rated flow rate in relation to the liquid temperature.

--- = air-cooled top.

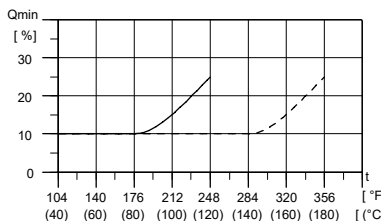

Minimum flow rate in percentage of nominal flow

12.1.7 Frequency of starts and stops

See data in the instructions that apply to the motor.

12.2 Electrical data

See the motor nameplate.

12.3 Dimensions and weights

Dimensions: see the appendix.

Weights: see the label on the packing.

13. Disposing of the product

This product or parts of it must be disposed of in an environmentally sound way.

1. Use the public or private waste collection service.
2. If this is not possible, contact the nearest Grundfos company or service workshop.



The crossed-out wheeled bin symbol on a product means that it must be disposed of separately from household waste. When a product reaches its end of life, take it to a collection point designated by the local waste disposal authorities. The separate collection and recycling of such products will help protect the environment and human health.

See also end-of-life information at www.grundfos.com/product-recycling.

Appendix A

A.1. NPSH

NPSH

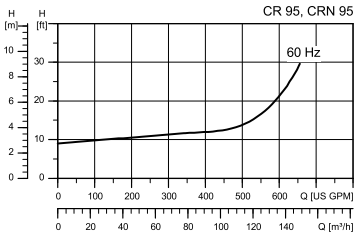

TM070428

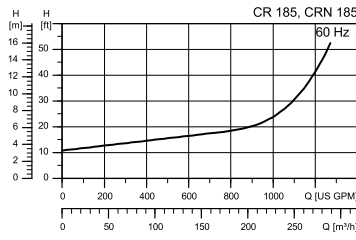

TM077575

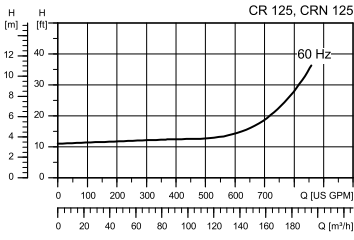

TM070429

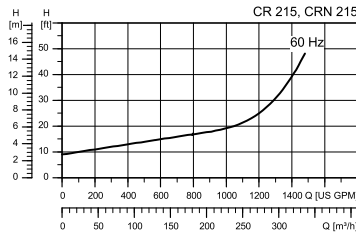

TM077576

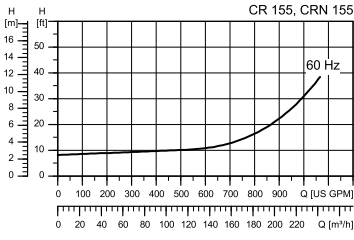

TM070430

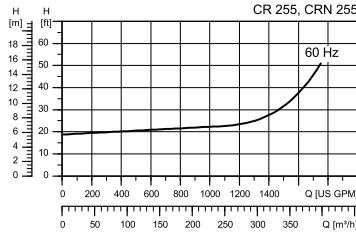

TM077577

A.2. Maximum inlet pressure

FR-CA: Pression d'aspiration maximale

ES-MX: Presión máxima admisible de succión

Pump type	Maximum inlet pressure [psi (bar)]
CR, CRN 95	
CR, CRN 95-1-1 → 95-2-2	145 (10)
CR, CRN 95-2-1 → 95-4-1	218 (15)
CR, CRN 95-4 → 95-5-1	290 (20)
CRN 95-6-3 → 95-8	290 (20)
CR, CRN 125	
CR, CRN 125-1-1 → 125-1	145 (10)
CR, CRN 125-2-2 → 125-3-2	218 (15)
CR, CRN 125-3-1 → 125-4-2	290 (20)
CRN 125-4-1 → 125-9-3	290 (20)
CR, CRN 155	
CR, CRN 155-1-1	145 (10)
CR, CRN 155-1 → 155-2-1	218 (15)
CR, CRN 155-2 → 155-3-2	290 (20)
CRN 155-3-1 → 155-8-3	290 (20)
CR, CRN 185	
CR, CRN 185-1-1 → 185-1	218 (15)
CR, CRN 185-2-2 → 185-6	290 (20)
CR, CRN 215	
CR, CRN 215-1-1	218 (15)
CR, CRN 215-1 → 215-5-1	290 (20)
CR, CRN 255	
CR, CRN 255-1-1	218 (15)
CR, CRN 255-1 → 255-4-1	290 (20)

A.3. Dimensions

FR-CA: Dimensions

ES-MX: Dimensiones

Pump type	PJE		ANSI		ANSI						
	L [inch] [(mm)]	H [inch] [(mm)]	D [inch] [(mm)]	L [inch] [(mm)]	H [inch] [(mm)]	ANSI flange	L ₁ [inch] [(mm)]	L ₂ [inch] [(mm)]	B ₁ [inch] [(mm)]	B ₂ [inch] [(mm)]	Ø
CR 95	-	-	-	14.96 (380)	5.51 (140)	4"	8.86 (225)	10.83 (275)	13.78 (350)	16.5 (419)	0.73 (18.5)
	14.96 (380)	5.51 (140)	5.56 (141.3)	14.96 (380)	5.51 (140)	4"	8.86 (225)	10.83 (275)	13.78 (350)	16.5 (419)	0.73 (18.5)
CR 125 CR 155	-	-	-	19.09 (485)	7.09 (180)	6"	10.83 (275)	13.07 (332)	16.73 (425)	19.65 (499)	0.89 (22.5)
	19.09 (485)	7.09 (180)	6.63 (168.3)	19.09 (485)	7.09 (180)	6"	10.83 (275)	13.07 (332)	16.73 (425)	19.65 (499)	0.89 (22.5)
CR 185 CR 215 CR 255	-	-	-	24.21 (615)	7.87 (200)	8"	13.78 (350)	16.34 (415)	20.08 (510)	23.58 (599)	1.04 (26.5)
	24.21 (615)	7.87 (200)	8.63 (219.1)	24.21 (615)	7.87 (200)	8"	13.78 (350)	16.34 (415)	20.08 (510)	23.58 (599)	1.04 (26.5)

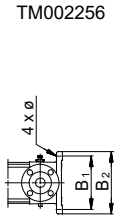

TM002256

TM070440

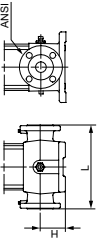

TM002252

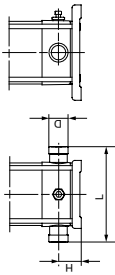

A.4. Sound pressure levels

FR-CA: Les niveaux de pression acoustique

ES-MX: Los niveles de presión sonora

2-pole 60 Hz NEMA				
Motor		LpA (ISO 3744)	LpA (ISO 3743-2 / ISO 1680 60 Hz)	LpA (ISO 3744)
HP	Phases	WEG TEFC [dB(A)]	Grundfos ML TEFC [dB(A)]	WEG ODP [dB(A)]
1/3	1	66	-	-
	3	65	58	-
1/2	1	66	-	-
	3	65	59	-
3/4	1	68	-	-
	3	65	59	-
1	1	68	-	-
	3	65	59	-
1 1/2	1	68	-	-
	3	68	58	-
2	1	68	-	-
	3	68	63	-
3	1	72	-	-
	3	68	63	-
5	1	75	-	-
	3	68	68	-
7 1/2	1	75	-	-
	3	70	68	-
10	1	75	-	-
	3	70	65	-
15	3	72	64.5	66
20	3	75	65	70
25	3	72	65.5	73
30	3	72	70.5	73
40	3	76	-	75
50	3	76	-	75
60	3	79	-	75
75	3	79	-	75
100	3	79	-	84
125	3	81	-	84
150	3	81	-	85
200	3	81	-	85
250	3	81	-	85
300	3	81	-	85

A.5. Vapor pressure H_v

FR-CA: Pression de vapeur H_v

ES-MX: Presión de vapor H_v

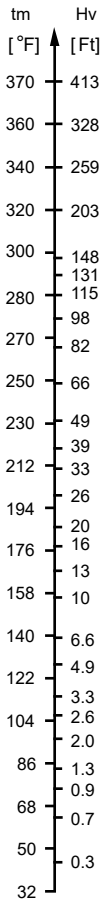

TM070326

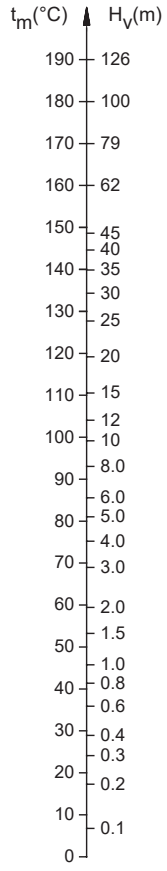

TM027445

U.S.A.

Global Headquarters for WU
856 Koomey Road
Brookshire, Texas 77423 USA
Phone: +1-630-236-5500

GRUNDFOS CBS Inc.
902 Koomey Road
Brookshire, TX 77423 USA
Phone: 281-994-2700
Toll Free: 1-800-955-5847
Fax: 1-800-945-4777

GRUNDFOS Pumps Corporation
9300 Loiret Boulevard
Lenexa, Kansas 66219 USA
Tel.: +1 913 227 3400
Fax: +1 913 227 3500

Canada

GRUNDFOS Canada inc.
2941 Brighton Road
Oakville, Ontario
L6H 6C9
Tel.: +1-905 829 9533
Fax: +1-905 829 9512

Mexico

Bombas GRUNDFOS de México
S.A. de C.V.
Boulevard TLC No. 15
Parque industrial Stiva Aeropuerto
Apodaca, N.L. 66600
Tel.: +52-81-8144 4000
Fax: +52-81-8144 4010

Revision Info

Last revised on 04-2021

99347135 08.2022

ECM: 1345704

www.grundfos.com

GRUNDFOS 

Trademarks displayed in this material, including but not limited to Grundfos and the Grundfos logo, are registered trademarks owned by The Grundfos Group. © 2022 Grundfos Holding AS, all rights reserved.