



### PERFORMANCE

- The Chef Express rapid cook oven utilizes a combination of convection heat, high speed impinged air, bottom infrared, and precision microwave to reduce cook times by more than 80% with chef-quality results. Chef Express ovens are equipped with a removable catalytic converter, which break down grease-laden vapors allowing for ventless operation.

### FEATURES

- Up to 80 recipes with 6 steps each
- USB port to upload/download recipes
- Easy to clean
- Adjustable temperature from 86F (30C) to 536F (280C)
- User Friendly Interface
- Cool to the touch exterior
- Certified ventless with easy removable catalytic converter
- Variable-speed impingement airflow
- Independently controlled top and bottom heaters
- Ventless side panels allow for zero side clearance installation
- Allows the use of metal pans
- Constructed from AISI430 (exterior) and AISI304 (interior) stainless steel
- Manual mode for on-the-fly cooking
- Warranty – 1 year parts and labor

### STANDARD ACCESSORIES

- Aluminum Paddle & USB Drive
- Baking / Pizza Stone
- Teflon Cooking Basket
- Lloyd Pan Panini Grill

\* Ultimate ventless allowance is dependent upon AHJ approval, as some jurisdictions may not recognize the ETL certification or application.

### VENTILATION

- ETL Mark listed for ventless certification.
- EPA 202 test
  - Product: Pepperoni Pizza
  - Results: 0.46 mg/m<sup>3</sup>
  - Ventless Requirements: <5.00 mg/m<sup>3</sup>
- Easy to remove catalytic converter reduces grease, smoke, and odor emissions.

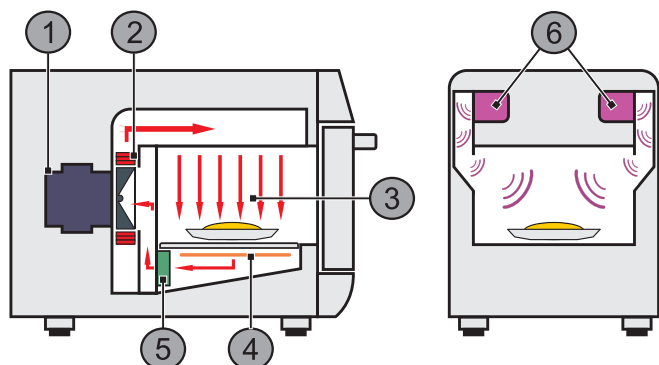

- |                       |                        |
|-----------------------|------------------------|
| 1. Blower Motor       | 4. IR heater           |
| 2. Impingement Heater | 5. Catalytic Converter |
| 3. Impinged Air       | 6. Magnetrons          |



### PRODUCT DIMENSIONS

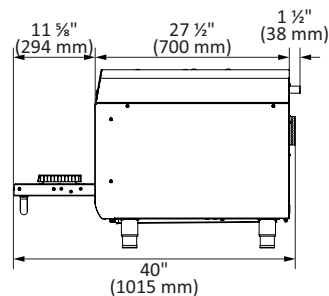
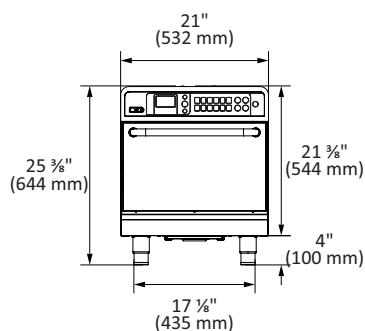
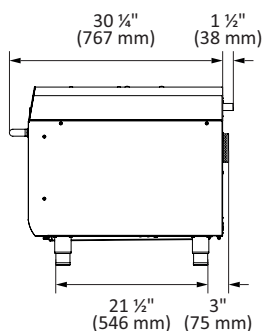

### INSTALLATION

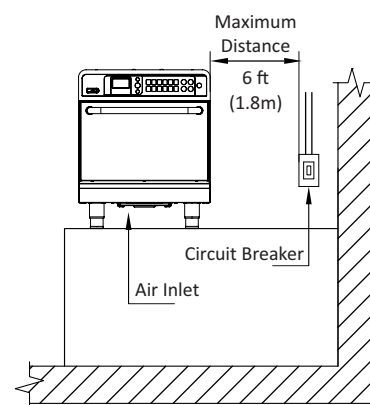
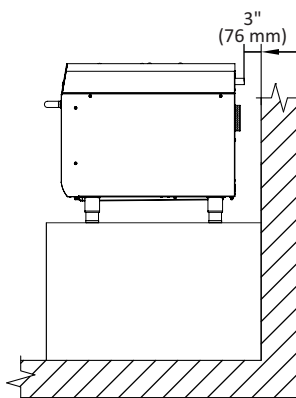
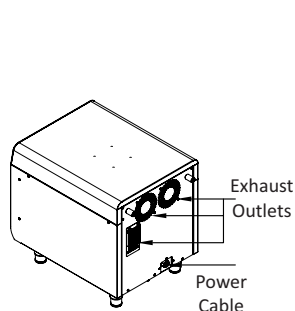

### ELECTRICAL SPECIFICATIONS

Ensure that the electrical characteristics of the building network are in accordance with the technical specifications located on the data badge located on rear panel of the unit. The outlet should be located no more than 6ft / 1.8m away from the unit.

This unit must be properly grounded to avoid electrical shock. This unit is equipped with a 3-prong plug. This plug must be connected to a properly installed and grounded outlet. In the event of an electrical short, properly grounding the unit reduces the risk of electrical shock by grounding the electrical current. The building electrical is the customer's responsibility.

Chef Express	Voltage (V)	Phases	Freq. (Hz)	Power (kW)	Circuit (A)	Consum. (kWh)	Cable	Socket
USA	208	Single	60	5.7	30	4	3x10AWG	NEMA 6-30
Canada	208	Single	60	5.7	30	4	3x10AWG	NEMA 6-30
Brazil	220	Single	60	6.3	32	4.4	3x4mm <sup>2</sup>	32A (2P+T)
Latin America 60Hz	220	Single	60	6.3	32	4.4	3x4mm <sup>2</sup>	32A (2P+T)
Latin America 50Hz	230	Single	50	7.2	32	5	3x4mm <sup>2</sup>	32A (2P+T)
Europe	230	Single	50	7.2	32	5	3x4mm <sup>2</sup>	32A (2P+T)

### GENERAL INSTRUCTIONS

The oven must be installed on a base or counter that supports the weight of the unit (approximately 194 lbs. / 88 kg)

For proper ventilation, a minimum space of 3" (76mm) between the rear of the oven and the wall is required.

Do not block the air inlets and exhaust outlets located on the bottom and rear of the oven.

It is not recommended for the unit to be positioned near stoves, deep fryers, hot plates and other equipment that releases fat, fumes and heat.

The oven must be installed at a leveled and ventilated location.

Improper installation may void the equipment warranty.

### DIMENSIONS

Chef Express	Product dimensions				Packing dimensions			
	Height	Width	Depth	Weight	Height	Width	Depth	Weight
	25 3/8" 644mm	21" 532mm	31 3/4" 805mm	194lbs 88kg	31 1/2" 800mm	22" 560mm	33 3/4" 860mm	242lb 110kg
Chamber Dimensions	Capacity		Height		Width		Depth	
	0.74 cu.ft 21L		5 3/4" 146mm		15 1/2" 394mm		14 1/4" 362mm	
Wall Clearance	Left Side		Back		Right Side			
	0" 0mm		3" 76mm		0" 0mm			