

JP-PS

Jet pumps with pressure switch, 115/230 V, 60 Hz

Service instructions



CONTENTS

	Page
1. General information	2
1.1 Hazard statements	2
1.2 Notes	2
2. Safety information for working on the product	3
3. Maintenance	3
4. Dismantling the product	3
4.1 Before dismantling the product	3
4.2 Dismantling the pressure switch	3
4.3 Dismantling the pump housing	4
4.4 Replacing the plugs	4
4.5 Dismantling the hydraulic parts	4
4.6 Dismantling the motor housing	5
5. Disconnecting the power cable from the pressure switch	6
5.1 Removing the motor fan	6
5.2 Removing the impeller	6
5.3 Removing the shaft seal	7
6. Assembling the product	8
6.1 Before assembling the product	8
6.2 Fitting the shaft seal	8
6.3 Fitting the impeller	9
6.4 Fitting the motor fan	9
6.5 Fitting the motor housing	9
6.6 Fitting the hydraulic parts	10
6.7 Fitting the pump housing	10
6.8 Connecting the power cable via the pressure switch	11
7. Additional information	13
7.1 Lubricant	13
7.2 Torques	13
7.3 Nameplate	13
7.4 Type key	14
7.5 Fault finding the product	14
7.6 Exploded view	15



Read this document before starting service work on the product. Installation and service work must comply with local regulations and accepted codes of good practice.

Observe the safety instructions in the installation and operating instructions for the product.

1. General information

1.1 Hazard statements

The symbols and hazard statements below may appear in Grundfos installation and operating instructions, safety instructions and service instructions.

**DANGER**

Indicates a hazardous situation which, if not avoided, will result in death or serious personal injury.

**WARNING**

Indicates a hazardous situation which, if not avoided, could result in death or serious personal injury.

**CAUTION**

Indicates a hazardous situation which, if not avoided, could result in minor or moderate personal injury.

The hazard statements are structured in the following way:

**SIGNAL WORD****Description of hazard**

Consequence of ignoring the warning.
- Action to avoid the hazard.

1.2 Notes

The symbols and notes below may appear in Grundfos installation and operating instructions, safety instructions and service instructions.



Observe these instructions for explosion-proof products.



A blue or grey circle with a white graphical symbol indicates that an action must be taken.



A red or grey circle with a diagonal bar, possibly with a black graphical symbol, indicates that an action must not be taken or must be stopped.



If these instructions are not observed, it may result in malfunction or damage to the equipment.



Tips and advice that make the work easier.

2. Safety information for working on the product

WARNING



Electric shock

Death or serious personal injury

- Switch off the power supply before you start any work on the product. Make sure that the power supply cannot be switched on accidentally.

WARNING



Electric shock

Death or serious personal injury

- The product is supplied with a grounding conductor and grounding-type attachment plug. To reduce the risk of electric shock, be certain that the product is connected only to a properly grounded, grounding-type receptacle (protective earth).

WARNING



Electric shock

Death or serious personal injury

- Power cables without a plug must be connected to a supply disconnecting device incorporated in the fixed wiring according to the local wiring rules.

WARNING



Chemical hazard

Death or serious personal injury

- Make sure that the product has only been used for water. If the product has been used for pumping aggressive liquids, flush the system with clean water before you start work on the product.

WARNING



Pressurized system

Death or serious personal injury

- Before dismantling the pump, drain the system or close the isolating valves on both sides of the pump. Slowly loosen the drain plug and unpressurize the system.

CAUTION



Impurities in the water

Minor or moderate personal injury

- Before the pump is used for supplying drinking water, flush the pump thoroughly with clean water.

CAUTION



Crushing of feet

Minor or moderate personal injury

- Wear safety shoes when handling the product.

CAUTION



Hot surface

Minor or moderate personal injury

- Use protective gloves if the liquid or ambient temperature is higher than 104 °F (40 °C).

CAUTION



Hot or cold liquid

Minor or moderate personal injury

- Make sure that escaping hot or cold liquid does not cause injury to persons or damage to the equipment.



Only qualified persons are allowed to service the pump.



Do not turn on the power supply until the pump has been filled with liquid.

3. Maintenance

The product is maintenance-free during normal operation. For cleaning, use a dry and dust-free cloth.

4. Dismantling the product



Position numbers of parts (numbers in brackets) refer to section [7.6 Exploded view](#).

4.1 Before dismantling the product

- Disconnect the power supply to the motor.
- Remove the power cable in accordance with local regulations.
- Gradually open a tap to release the pressure in the pump.
- Remove the drain plug (26) to drain the pump.
- Remove the pump from the plumbing.

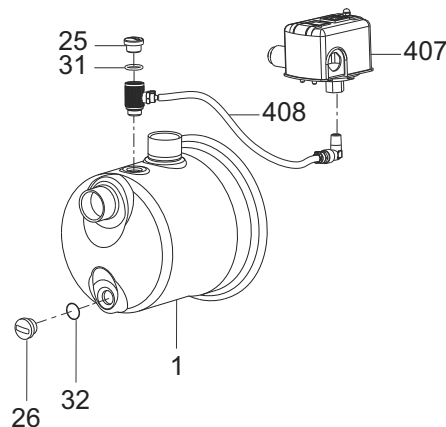

Fig. 1 Plugs (25, 26), pressure switch (407), and pressure switch connections (408)

4.2 Dismantling the pressure switch

1. Loosen the nut on the top cover of the pressure switch (407).
2. Lift up the pressure switch cover and set it aside.
3. Inside the pressure switch, use a large flat screw driver to turn the locking ring counterclockwise to loosen it.
4. Use small pliers or a wrench to loosen the pressure switch (407) and pressure switch connections (408).
5. Remove the pressure switch (407) and pressure switch connections (408) from the pump.

TM07 4518 1419

4.3 Dismantling the pump housing

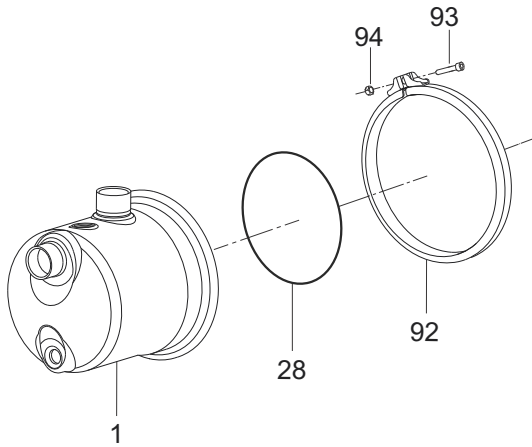

Fig. 2 Dismantling the pump housing

1. Place the pump vertically with the inlet facing upwards.
2. Unscrew the clamp ring (92) by loosening screw (93) and nut (94).
3. Remove the clamp ring (92) from the recess. Use two flat screw drivers to lift the clamp ring from the recess.

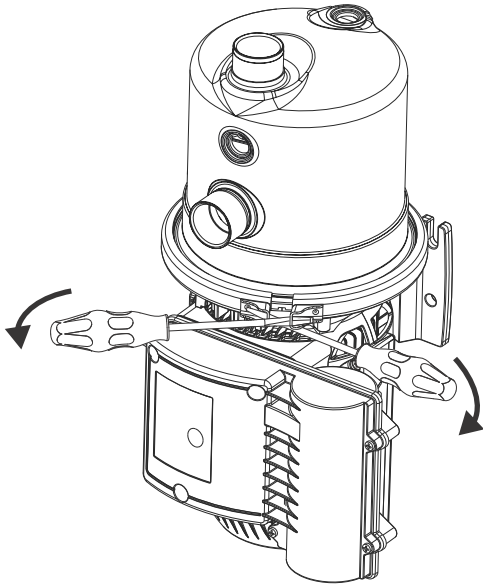

Fig. 3 Removing the clamp ring

4. Remove the pump housing (1) including the hydraulic parts (20 and 21).
5. Remove the O-ring (28).

4.4 Replacing the plugs

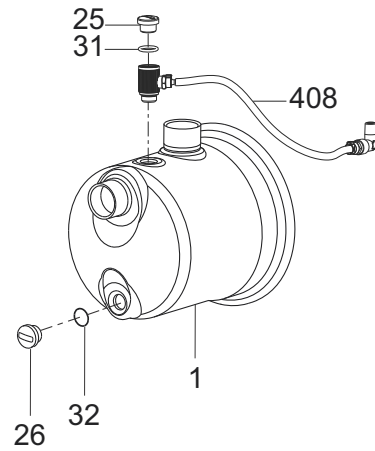

Fig. 4 Replacing the plugs

To replace the fill plug (25) and drain plug (26):

1. Remove the two plugs (25, 26) by turning each plug counterclockwise with a big flat screwdriver.
2. Lubricate the O-ring seats on the pump housing (1). See section [7.1 Lubricant](#).
3. Place the new plugs (25, 26) and O-rings (31, 32). Fasten the plugs (25, 26) by turning the plug clockwise with a large flat screwdriver.

4.5 Dismantling the hydraulic parts

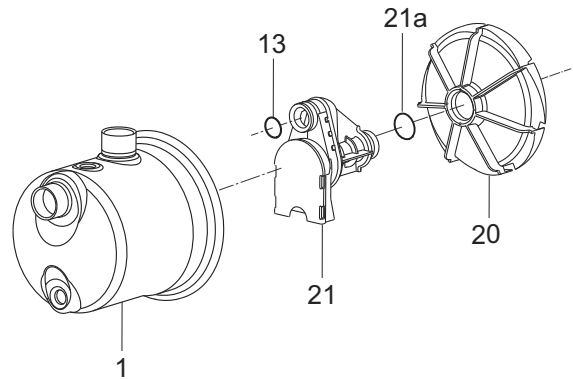

Fig. 5 Hydraulic parts and pump housing

1. Place the pump housing (1) vertically with the inlet facing upwards.
2. Use a suitable tool which fits inside the inlet and gently press down on the venturi tube (21) to loosen the hydraulic parts (20, 21, 21a and 13).

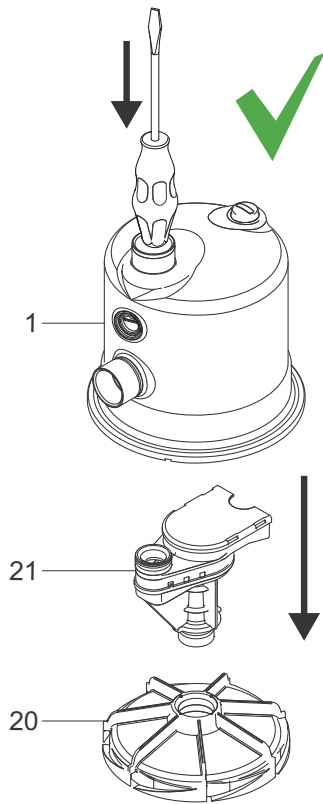

Fig. 6 Removal of hydraulic parts

! Do not try to remove the diffuser (20) by using screwdrivers or similar tools, as it might break.

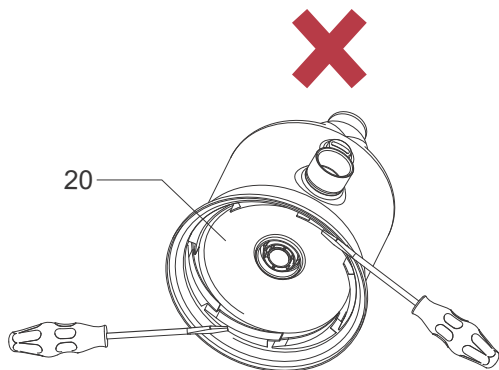
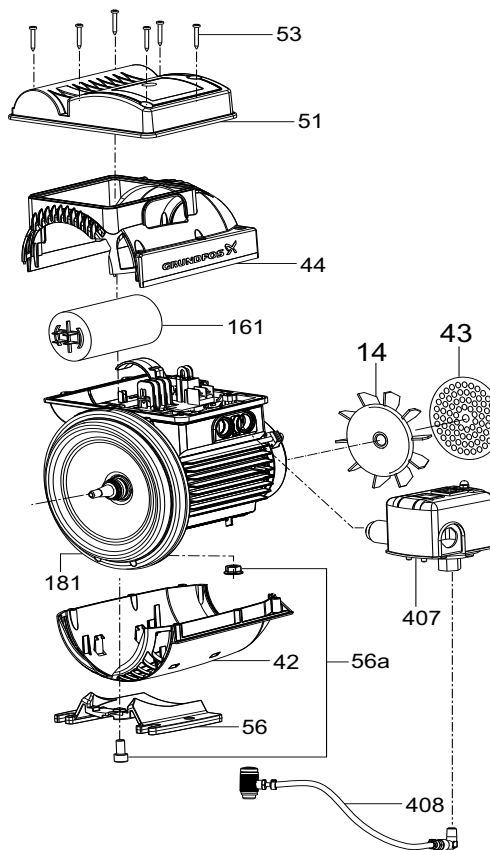

Fig. 7 Incorrect way to remove the diffuser

4.6 Dismantling the motor housing



TM07 4538 1419

TM07 3465 1319

Fig. 8 Dismantling the motor housing

1. Remove the terminal box cover (51) and upper motor shell housing (44) by loosening the screws (53).
2. Disconnect the power connections as required and follow the instructions in section 5. [Disconnecting the power cable from the pressure switch.](#)
3. Remove the motor housing grid (43).
4. Remove the base plate (56) by loosening the screw and nut (56a).
5. Remove the lower motor housing (42).

TM07 3813 0519

5. Disconnecting the power cable from the pressure switch



If you are replacing the motor housing (42, 44), disconnect the power cable from the pressure switch (407).

If you are replacing the impeller, remove the lower motor housing (42) and the upper motor housing (44) and disconnect the power cable from the pressure switch (407).

1. Locate the power-supply terminal and cable clamp inside the pressure switch.

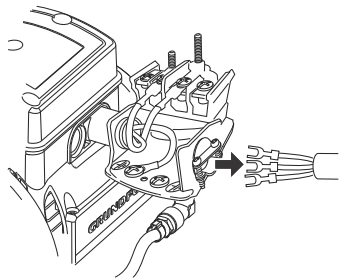

TM07 4373 1319

Fig. 9 Disconnecting the power cable

2. Loosen the three wires from the pressure switch.
3. Loosen the screw that holds the cable clamp.
4. Pull out the cable through the cable gland located on the side of the pressure switch.

5.1 Removing the motor fan

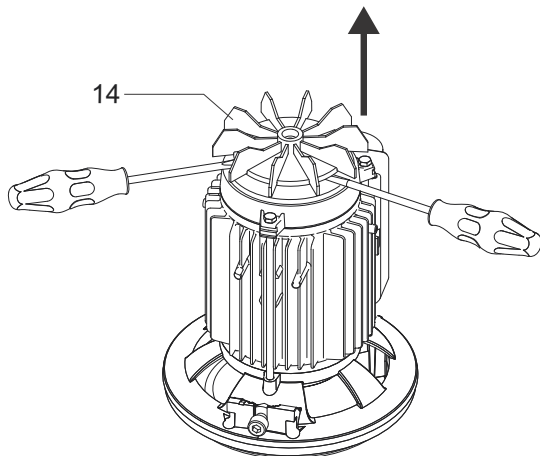

TM07 4329 1319

Fig. 10 Removing the motor fan

1. Remove the motor fan (14) from the shaft with two large flat screw drivers. Make sure to use sufficiently large screw drivers. Place the screw drivers between motor flange and fan at any two points.

5.2 Removing the impeller

1. Place the motor vertically with the impeller (19) facing upwards.
2. Clamp the motor shaft end in a vice with soft copper or aluminium jaw faces to protect the shaft end.

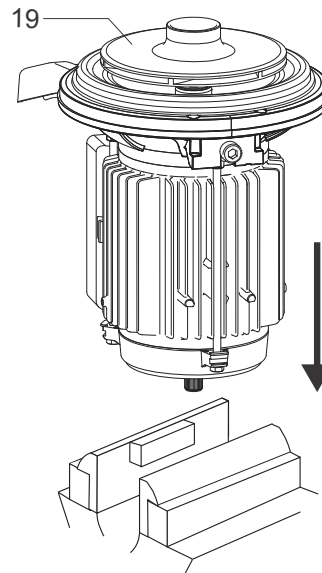

TM07 3817 0519

Fig. 11 Placing the motor shaft in a vice

3. Turn the impeller (19) counterclockwise by hand and remove it.

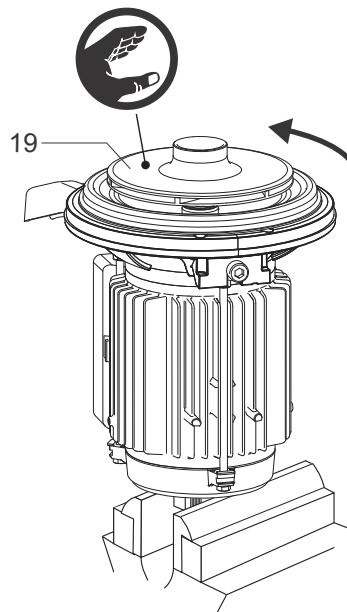

TM07 3818 0519

Fig. 12 Removing the impeller

5.3 Removing the shaft seal



Do not touch the seal faces.

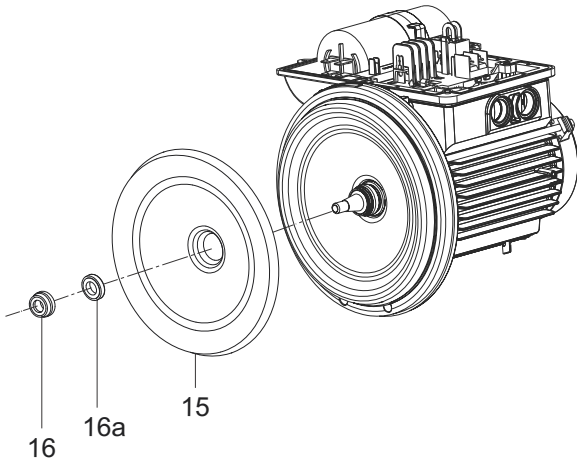

Fig. 13 Shaft seal and seal disc

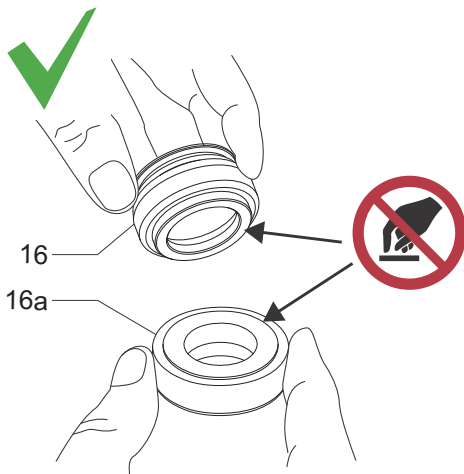

Fig. 14 How to hold the shaft seal correctly

1. Remove the rotating part of the shaft seal (16) by inserting two flat screw drivers in the shaft seal spring. Lever the screw drivers against any two points at the edge of the seal disc.

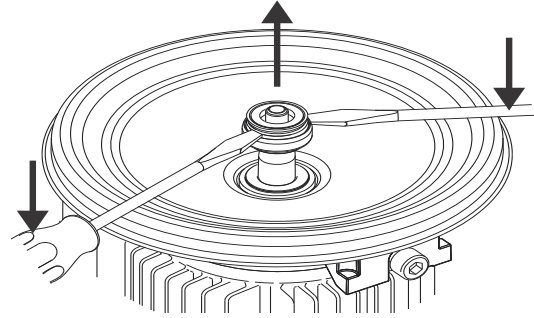

Fig. 15 Removing the rotating part of the shaft seal

2. Remove the seal disc (15) including the stationary part of the shaft seal (16a).
3. Remove the stationary shaft seal ring (16a) from the seal disc (15) by pushing gently with a finger from below. Hold the seal ring on the lower side and on the rubbery outer diameter. Do not touch the seal face.

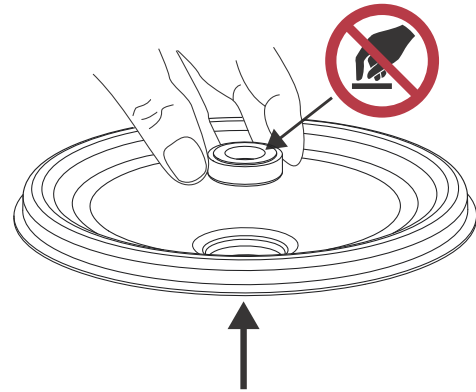

Fig. 16 Removing the stationary part of the shaft seal

TM07 4366 1319

TM07 3820 0519

TM07 3821 0519

TM07 3822 0519

6. Assembling the product



Position numbers of parts (numbers in brackets) refer to section [7.6 Exploded view](#).

6.1 Before assembling the product

- Clean and check all parts.
- Replace defective parts.

6.2 Fitting the shaft seal



Do not touch the seal faces.

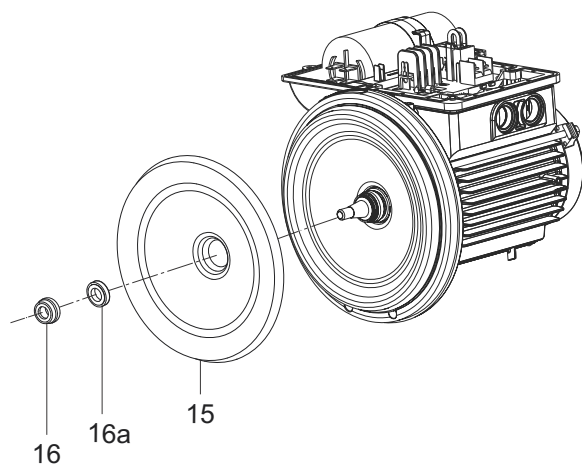

Fig. 17 Shaft seal and seal disc



Fig. 18 How to correctly hold the shaft seal

1. Clamp the motor shaft end in a vice with soft copper or aluminium jaw faces to protect the shaft end. See [fig. 11](#).
2. Lubricate the seal disc opening. See section [7.1 Lubricant](#).

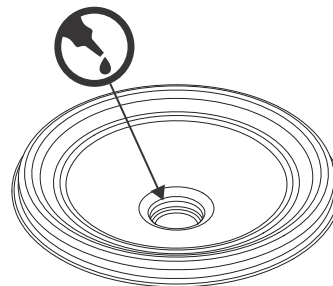

Fig. 19 Lubricating the seal disc

3. Fit the stationary part of the shaft seal (16a) inside the seal disc (15).



Fig. 20 Fitting the stationary part of the shaft seal

4. Lubricate the shaft. See section [7.1 Lubricant](#).
5. Place the seal disc (15) with the stationary part of the shaft seal (16a) on the shaft and make sure the seal disc (15) centers on the motor flange.

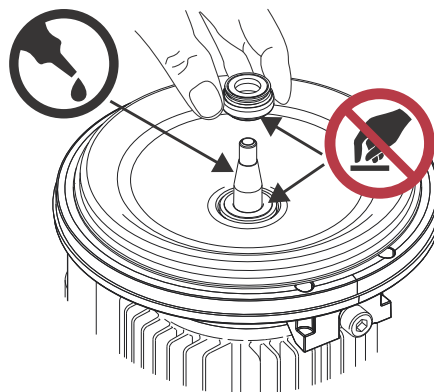

Fig. 21 Lubricating the shaft and placing the rotating part of the shaft seal.

6. Place the rotating part of the shaft seal (16) on the shaft and press it down with two fingers.

TM07 3823 0519

TM07 3824 0519

TM07 4366 1319

TM07 3825 0519

TM07 3820 0519

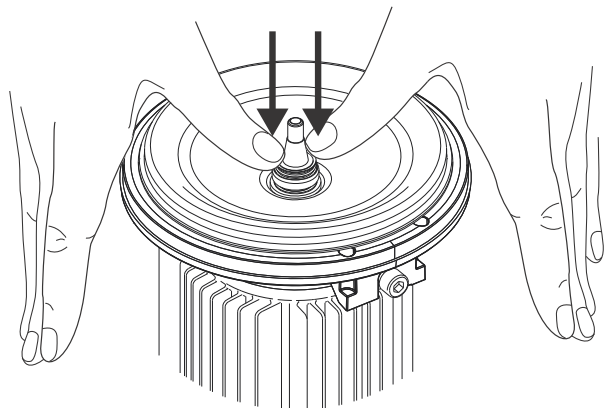

TM07 3826 0519

Fig. 22 Fitting the rotating part of the shaft seal

6.3 Fitting the impeller

1. Fit the impeller (19) on the shaft.
2. Spin the impeller (19) clockwise and tighten by hand until you feel the resistance of the mechanical stop.

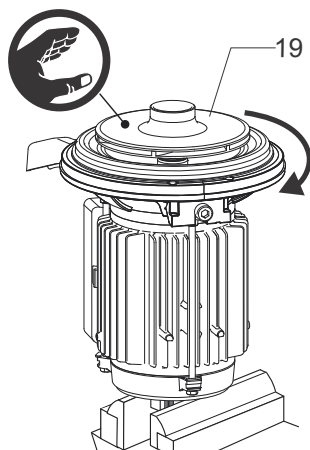

TM07 3827 0519

Fig. 23 Fitting the impeller

6.4 Fitting the motor fan

1. Place the pump in a vertical position with the shaft end facing upwards. The surface must be smooth or soft to protect the impeller (15) facing downwards.
2. Fit the motor fan (14) on the shaft by hand.

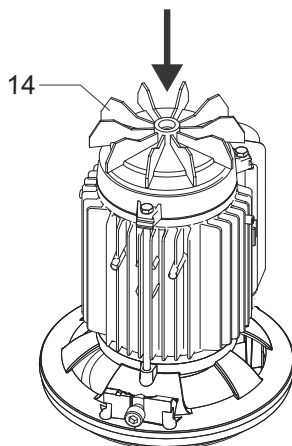
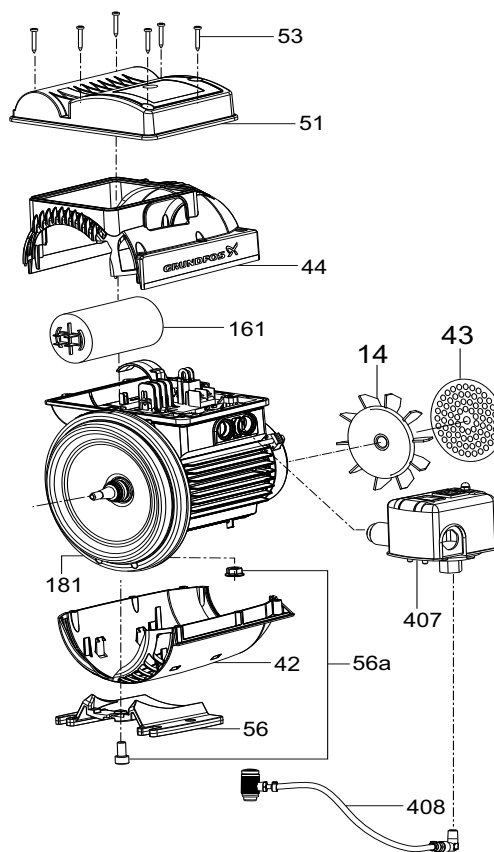

Fig. 24 Fitting the motor fan

TM07 4369 1319

6.5 Fitting the motor housing



TM07 3465 1319

Fig. 25 Fitting the motor housing

1. Place the pump in a vertical position with the motor fan (14) facing upwards.

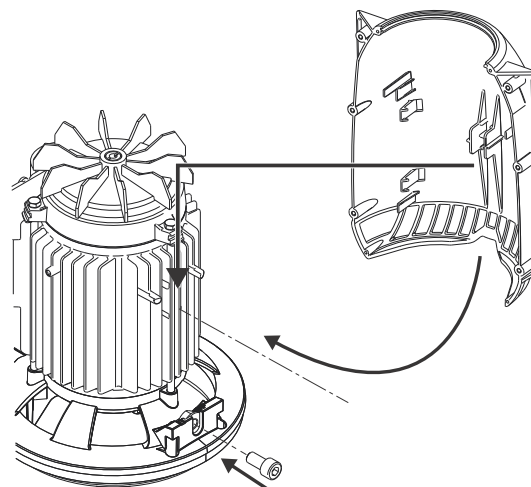

TM07 3829 0519

Fig. 26 Fitting the nut and the lower motor housing

2. Place the nut (56a) in the groove on the motor flange.
3. Fit the lower motor housing (42). Align the guides on the inside of the lower motor housing (42) with the metal cooling ribs on the stator housing. Click the motor housing in place.
4. Mount the foot (56) and tighten the screw (56a). Torque: 12 ± 1 Nm.
5. Fit the motor housing grid (43) in the groove in the motor shell (42).

6. Fit the upper motor housing (44).
7. Fasten the screws (53) that hold the motor housing together.
Torque: 1.5 ± 0.1 Nm.



Verification of assembly:

Turn the shaft by rotating the impeller (19) clockwise and check that the motor fan (14) does not touch the motor housing (42 and 44).

8. Fit the terminal box lid (51) and fasten the screws (53) that hold it in place.
9. Follow the instructions below on how to connect the power cable in section [6.6 Fitting the hydraulic parts](#).

6.6 Fitting the hydraulic parts

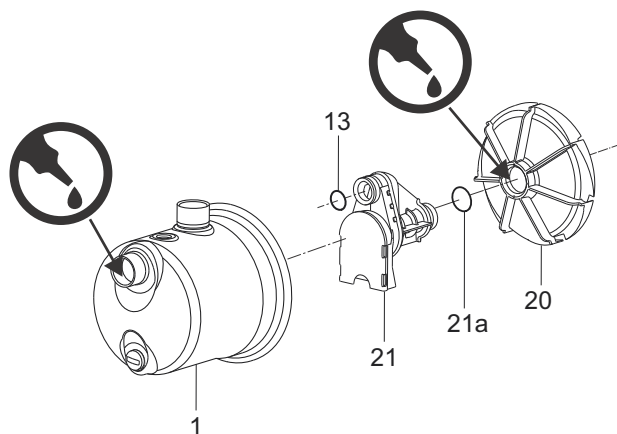

Fig. 27 Exploded view of hydraulic parts and pump housing

1. Lubricate the O-ring seat on the diffuser (20). See section [7.1 Lubricant](#).
2. Fit the two O-rings (13, 21a) on the venturi tube (21).
3. Assemble the venturi tube (21) and diffuser (20) by hand.
4. Lubricate the O-ring seat inside the inlet on the pump housing (1). See section [7.1 Lubricant](#).
5. Fit by hand the venturi tube (21) and diffuser (20) inside the pump housing (1).

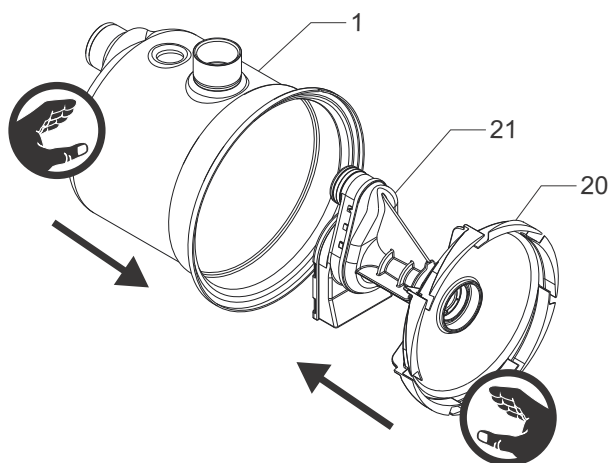

Fig. 28 Fitting the hydraulic parts in the pump housing

6.7 Fitting the pump housing

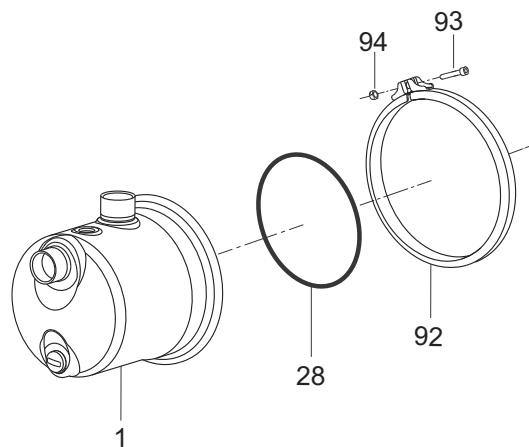

Fig. 29 Exploded view of the pump housing

1. Place the pump in a vertical position with the motor housing grid (43) facing downwards.
2. Fit the O-ring (28) on the seal disc (15). No lubrication is needed. Run a screw driver along the ring to remove any twisting.

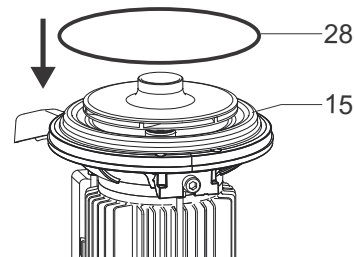

Fig. 30 Fitting the O-ring on the seal disc

3. Fit the pump housing (1) so that the cut-out on the edge of the pump housing is aligned with the marker on the edge of the motor flange.

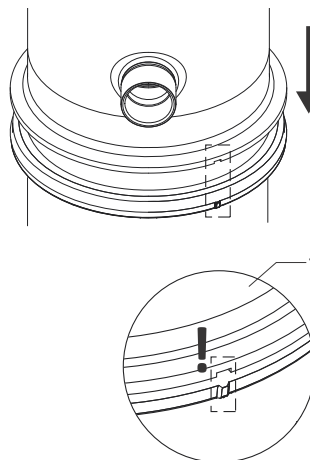

Fig. 31 Aligning the pump housing on the motor flange

4. Fit the clamp ring (92) on the recess. Use two flat screw drivers to widen the clamp.

TM07 4533 1419

TM07 3835 0919

TM07 3833 0519

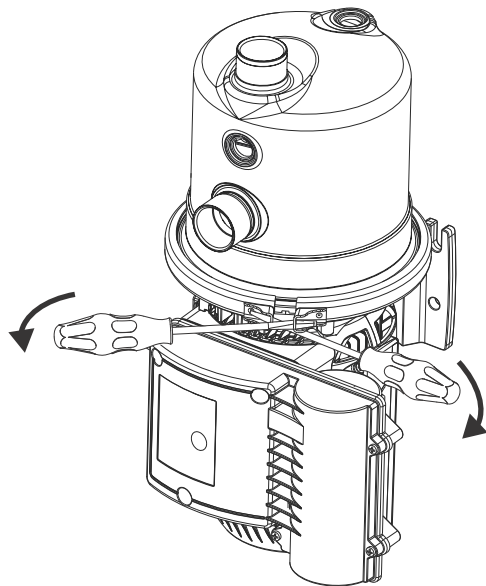

Fig. 32 Fitting the clamp ring

5. Place the screw (93) on one side and nut and washer (94) on the other side and tighten. Torque: 6.1 ± 0.1 Nm.

TM07 4535 1419

6.8 Connecting the power cable via the pressure switch

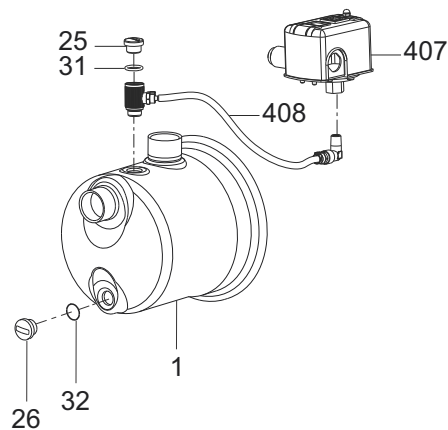

Fig. 1 Plugs and pressure switch connections

1. Locate the power-supply terminal and cable clamp inside the pressure switch (407).

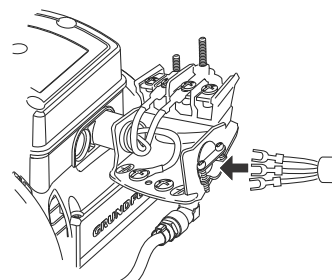

Fig. 2 Connecting the power cable via the pressure switch

2. Loosen the cable clamp.
3. Push one end of the cable through the cable gland located on the side of the pressure switch.
4. Connect the cable conductors to the power-supply terminals inside the pressure switch. See wiring diagram.
5. Tighten the terminal screws. Torque: 2.2 ± 0.2 Nm.
6. Tighten the cable clamp screw. Torque: 1.5 ± 0.1 Nm. Make sure not to overtighten the cable clamp screw.
7. Fit the cover onto the pressure switch and fasten the nut on the top of the pressure switch cover.

TM07 4518 1419

TM07 4374 1319

6.8.1 Wiring diagrams

Pressure switch to 115 V power cable

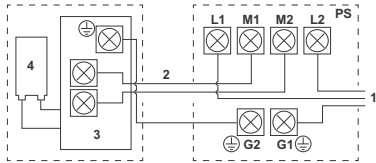

TM07 4151 1319

Pos.	Description
PS	Pressure switch
1	Power cable (in)
2	To motor (out)
3	Motor
4	Capacitor

From power cable to pressure switch:

G1	Green (ground)
L1	Black (live)
L2	White (neutral)

From pressure switch to motor:

G2	Yellow (ground)
M1	Brown (live)
M2	Blue (neutral)

Pressure switch to 230 V power cable

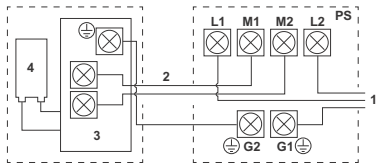

TM07 4151 1319

Pos.	Description
PS	Pressure switch
1	Power cable (in)
2	To motor (out)
3	Motor
4	Capacitor

From power cable to pressure switch:

G1	Green (ground)
L1	Black (live)
L2	Red (live)

From pressure switch to motor:

G2	Yellow (ground)
M1	Brown (live)
M2	Blue (neutral)

Pressure switch to 115 V residential hardwiring

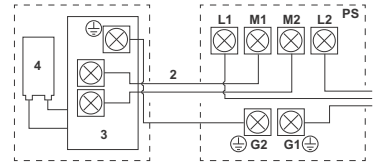

TM07 4151 1319

Pos.	Description
PS	Pressure switch
1	Residential hardwiring (in)
2	To motor (out)
3	Motor
4	Capacitor

From residential hardwiring to pressure switch:

G1	Bare copper (ground)
L1	Black (live)
L2	White (neutral)

From pressure switch to motor:

G2	Yellow (ground)
M1	Brown (live)
M2	Blue (neutral)

Pressure switch to 230 V residential hardwiring

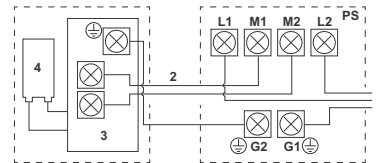

TM07 4151 1319

Pos.	Description
PS	Pressure switch
1	Residential hardwiring (in)
2	To motor (out)
3	Motor
4	Capacitor

From power cable to pressure switch:

G1	Bare copper (ground)
L1	Black (live)
L2	Red (live)

From pressure switch to motor:

G2	Yellow (ground)
M1	Brown (live)
M2	Blue (neutral)

7. Additional information

7.1 Lubricant

We recommend using soapy water.

7.2 Torques

Pos.	Description	Torque [Nm]
56a	Screw for mounting the foot (56a)	12 ± 1
-	Screws that hold the motor housing together (42 and 44)	1.5 ± 0.1
-	Screws for wiring in the terminal box	2.2 ± 0.2
-	Cable clamp screw in the terminal box	1.5 ± 0.1
53	Screws for mounting the cover (52) onto the terminal box	1.5 ± 0.1
93	Screw for mounting the clamp ring (92)	6.1 ± 0.1
94	Nut for mounting the clamp ring (92)	6.1 ± 0.1

7.3 Nameplate



Fig. 3 Nameplate example for JP-PS

Pos.	Description
1	Type (see the type key)
2	Min. flow rate and max. flow rate [gpm]
3	Min. head and max. head [ft]
4	Max. pressure [psi]
5	Supply voltage [V]
6	Enclosure type
7	Approvals
8	Full-load current [A]
9	Speed of rotation [rpm]
10	Country of origin
11	Capacitor data
12	Power consumption [Hp]
13	Rated power [Hp]
14	Insulation class
15	Enclosure class
16	Serial number
17	Max. liquid temperature [°F]
18	Max. ambient temperature [°F]
19	Factory and production code, year and week
20	Product number
21	Frequency
22	Service factor

TM07 4087 1319

7.4 Type key

Example:

JP PS 18-05-154 1x115/230 V 60 Hz Conduit XX

Code	Description
JP	Jet Pump
PS	Pressure Switch
18	Nominal flow rate [US gpm]
05	Horsepower [Hp]
154	Max. head [ft]
1x115/230V	Dual voltage (115 or 230 V)
60 Hz	Frequency [Hz]
Conduit	Type of power connection
XX	Country of origin

7.5 Fault finding the product

Fault finding procedures are described in the installation and operating instructions. Use the QR code or link below:



<http://net.grundfos.com/qr/i/99613293>

7.6 Exploded view

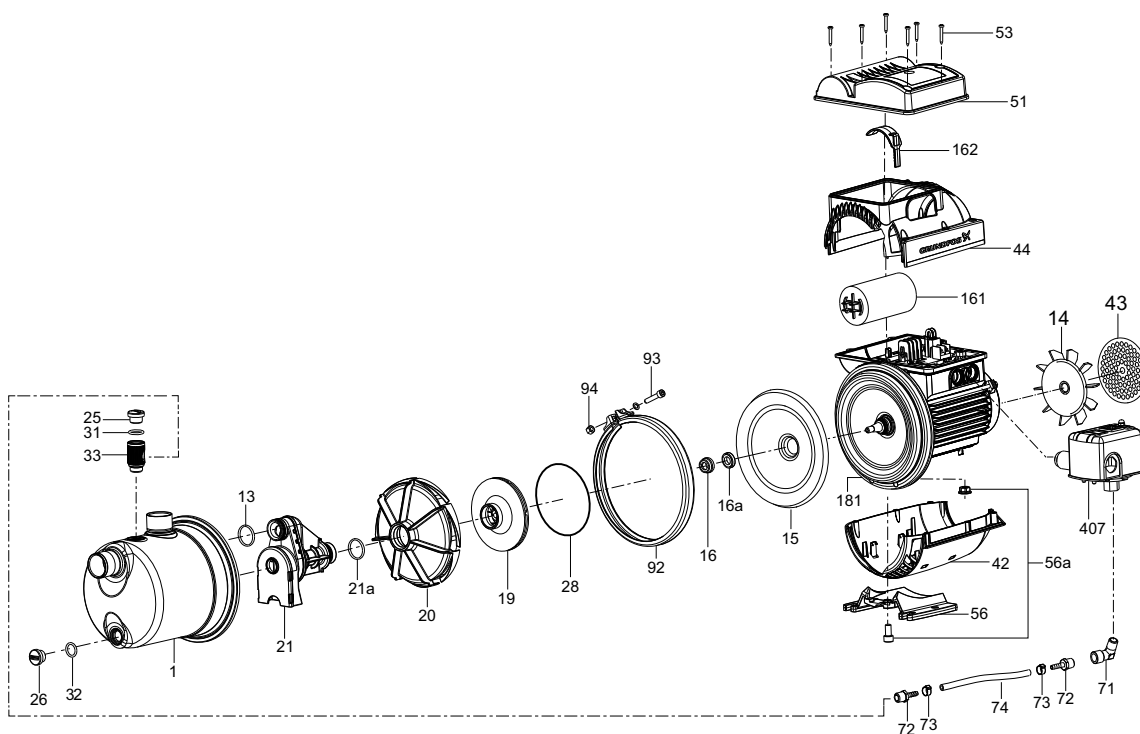

TM07 4372 1319

Pos.	Component	Material
1	Pump housing	Stainless steel AISI 304 (EN 1.4301)
13	O-ring	NBR
14	Motor fan	Composite
15	Seal disc	Stainless steel AISI 304 (EN 1.4301)
16	Shaft seal, rotary part	Carbon + NBR + AISI 304
16a	Shaft seal, stationary part	Alox + NBR
19	Impeller	Composite
20	Diffuser	Composite
21	Venturi tube	Composite
21a	O-ring	NBR
25	Plug (fill)	Composite
26	Plug (drain)	Composite
31	O-ring	NBR
32	O-ring	NBR
33	Connection extension	Stainless steel AISI 304 (EN 1.4301)
42	Lower motor housing	Composite
43	Motor housing grid	Stainless steel AISI 304 (EN 1.4301)
44	Upper motor housing	Composite
49	Impeller	Composite
51	Terminal box cover	Composite
53	Screws	
56	Base plate	Aluminium
74	Tubing	Polyurethane
92	Pump house ring	Stainless steel AISI 304 (EN 1.4301)
161	Capacitor	Composite
181	Motor flange	Aluminium
407	Pressure switch	Composite

GRUNDFOS Kansas City

9300 Loiret Blvd.
Lenexa, Kansas 66219
Phone: (913) 227-3400
Fax: (913) 227-3500

www.grundfos.us

GRUNDFOS Canada

2941 Brighton Road
Oakville, Ontario L6H 6C9 Canada
Phone: +1-905 829 9533
Telefax: +1-905 829 9512

www.grundfos.ca

GRUNDFOS México

Boulevard TLC No. 15
Parque Industrial Stiva Aeropuerto
C.P. 66600 Apodaca, N.L. México
Phone: 011-52-81-8144 4000
Fax: 011-52-81-8144 4010

www.grundfos.mx

99615172 0519
ECM: 1261106

Trademarks displayed in this material, including but not limited to Grundfos, the Grundfos logo and "be think innovate" are registered trademarks owned by The Grundfos Group. All rights reserved. © 2019 Grundfos Holding A/S, all rights reserved.