

JP PS

Jet pumps with pressure switch, 115/230 V, 60 Hz

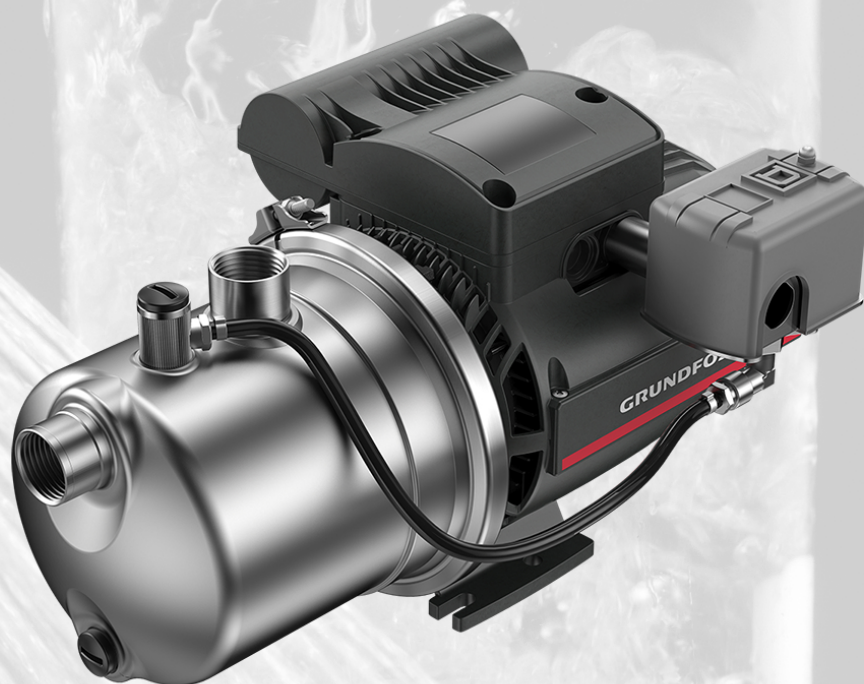

1. Product introduction	3
Product overview, JP PS	3
Applications	3
Pumped liquids	3
Features and benefits	3
Motor	3
Performance range	4
Product range	5
Identification	6
2. Construction	7
Material specification	7
3. Installation and operation	8
Mechanical installation	8
Electrical connection	11
4. Selection	12
Selection guide	12
5. Performance curves	13
How to read the curve charts	13
Curve charts, JP PS	14
6. Technical data	16
Dimensions and weights	16
Operating conditions	16
Product numbers	17
Electrical data	18
Approvals and marks	18
7. Grundfos Product Center	19

1. Product introduction

Grundfos JP PS pumps are designed for domestic use to ensure a constant supply of clean water to households, gardens, and light commercial applications.

JP PS is a self-priming, single-stage centrifugal jet pump. The pump has excellent suction capacity and is designed for long and trouble-free operation. The built-in ejector with guide vanes ensures optimum self-priming properties. The pressure switch gives more comfort to the user, as it allows the pump to start and stop automatically according to demand. The pump housing is made of stainless steel.

Product overview, JP PS

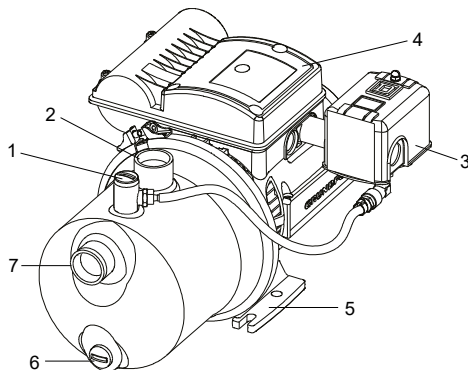

TM074051

Pos.	Description
1	Priming plug
2	Outlet connection, 1" NPT
3	Pressure switch and cable connection
4	Terminal box
5	Base plate
6	Drain plug
7	Inlet connection, 1" NPT

Applications

JP PS pumps are suitable for domestic water supply, where pressure boosting and self-priming is needed. The product can be used in a wide variety of applications, such as these:

- houses and duplexes, to boost the pressure of water coming from a break tank, roof tank or a well
- garden irrigation
- car wash
- small-scale agriculture and horticulture
- light commercial applications.

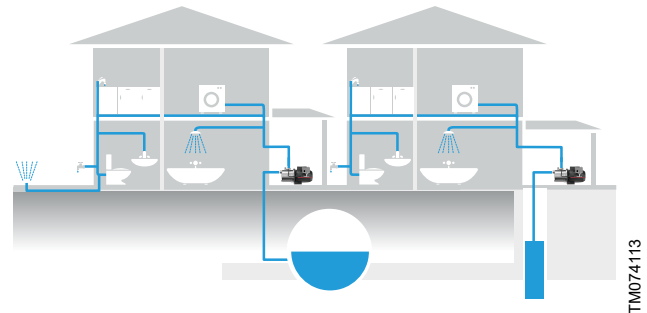

TM074113

Example of applications with JP PS

Pumped liquids

The product is suitable for pumping clean, thin, non-aggressive, non-toxic and non-explosive liquids without solid particles or fibers. Examples of liquids:

- potable water
- rainwater.

Features and benefits

JP PS for pressure-switch-based boosting

JP PS has a pressure switch to control pump operation. The pressure switch has a preset cut-in pressure and a cut-off pressure to turn the pump on and off according to demand.

JP PS features include:

- Self-priming and excellent suction lift of up to 26 ft (8 m)
- High quality pressure switch for auto stop/start
- Robust end suction design with top discharge
- Corrosion-resistant stainless steel construction
- Thermal and overload protection
- Dual voltage 115/230 V
- Built-in ejector complete with clean-out port to clear blockages from nozzle

Motor

The motor is air-cooled and equipped with oversized, sealed, greased-for-life ball bearings to ensure silent operation and minimum service.

The motors are single phase, have a built-in thermal switch and require no additional motor protection.

Performance range

The performance curves show the performance range of JP PS pumps.

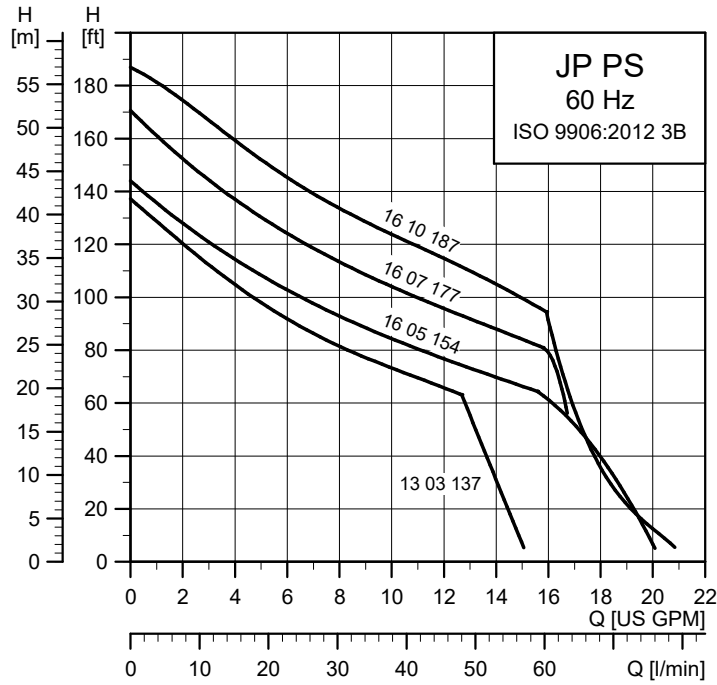

Performance range, JP PS

Related information

[Product range](#)

[Product numbers](#)

TM073799

Product range

JP PS 60 Hz, dual voltage 115/230 V, conduit connection

Model	Max. flow rate [gpm (m ³ h)]	Nom. flow rate [gpm (m ³ h)]	Hp	Max. head [ft (m)]	Nom. head [ft (m)]	Product number
JP PS 13 03 137	15 (3)	13 (3)	0.3	137 (42)	64 (36)	99463938
JP PS 16 05 154	20 (4)	18 (4)	0.5	145 (44)	65 (39)	99463939
JP PS 16 07 177	17 (4)	18 (4)	0.75	171 (52)	80 (47)	99463940
JP PS 16 10 187	21 (5)	22 (5)	1.0	187 (57)	95 (55)	99463941

Related information

[Performance range](#)

[Product numbers](#)

Identification

Nameplate example for JP PS

Pos.	Description
1	Type: JP PS 16 10 187
2	Qmin: 1.76 US gpm
3	Hmin: 5 ft
4	pmax: 87 psi
5	U: 1x115 V~
6	ENCLOSURE TYPE 3R
7	703194
8	I1/I: 13.8 A
9	rpm: 3400
10	Made in China by Grundfos
11	80 µF / 250 V~
12	THERMALLY PROTECTED
13	P1: 1.48 kW / 2 HP
14	IP:44
15	Class:F
16	Serial nr. 148083
17	Tmax liquid: 104 °F S1/140 °F S3
18	Tmax amb: 104 °F S1/131 °F S3
19	No: 99463941
20	P5 20 39
21	60 Hz
22	SF: 1.40

TM074087

Nameplate, JP PS

Pos.	Description
1	Type (see the type key)
2	Min. flow rate and max. flow rate [gpm]
3	Min. head and max. head [ft]
4	Max. pressure [psi]
5	Supply voltage [V]
6	Enclosure type
7	Approvals
8	Full-load current [A]
9	Speed of rotation [rpm]
10	Country of origin
11	Capacitor data
12	Power consumption [hp]
13	Rated power [hp]
14	Insulation class
15	Enclosure class
16	Serial number
17	Max. liquid temperature [°F]
18	Max. ambient temperature [°F]
19	Factory, production code, year and week
20	Product number
21	Frequency
22	Service factor

Related information

[Type key, JP PS](#)

Type key, JP PS

Example: JP PS 16-10-187 1x115/230V 60 Hz Conduit XX	
Type designation	Description
JP	Jet pump
PS	Pressure switch
16	Nominal flow rate [US gpm]
10	Horsepower [hp]
187	Max. head [ft]
1x115/230V	Dual voltage (115 or 230 V)
60 Hz	Frequency [Hz]
Conduit	Type of power connection
XX	Country of origin (Example: HU (Hungary))

Related information

[Nameplate example for JP PS](#)

2. Construction

Material specification

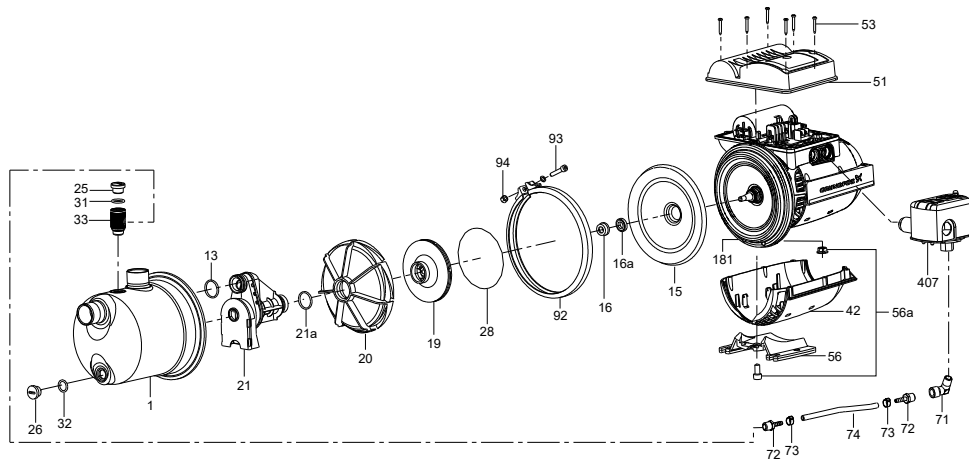

TM074504

Pos.	Component	Material	Pos.	Component	Material
1	Pump housing	Stainless steel AISI 304 (EN 1.4301)	33	Connection extension	Stainless steel AISI 304 (EN 1.4301)
13	O-ring	NBR	42	Motor housing	Composite
15	Seal disc	Stainless steel AISI 304 (EN 1.4301)	51	Terminal box cover	Composite
16	Shaft seal, rotary part	Carbon + NBR + AISI 304	56	Base plate	Aluminum
16a	Shaft seal, stationary part	Alox + NBR	71	Clip	
19	Impeller	Composite	72	Fitting 1/4 NPT	
20	Diffuser	Composite	73	Cable clamp	
21	Venturi tube	Composite	74	Tubing	Polyurethane
21a	O-ring	NBR	92	Pump housing ring	Stainless steel AISI 304 (EN 1.4301)
25	Plug (fill)	Composite	93	Screw	
26	Plug (drain)	Composite	94	Nut	
28	O-ring	NBR	161	Capacitor	
31	O-ring	NBR	181	Motor flange	Aluminum
32	O-ring	NBR	407	Pressure switch	Composite

3. Installation and operation

Mechanical installation

Placing the pump above ground is generally a convenient way to establish a water or rainwater supply. The pump can be installed both indoors and outdoors in a well ventilated location. When installed outdoors, the product needs a suitable cover to protect it from exposure to direct sunlight, rain, snow and frost. Place the product as close to the liquid to be pumped as possible to minimize the length of the inlet pipe. For ease of access we recommend a clearance of 20 in (0.5 m) on three sides which should include the rear side for cooling of the motor. Fasten the product to a solid horizontal foundation with a maximum inclination angle of $\pm 5^\circ$. The base plate must be facing downwards. If the pump is used for pumping rainwater or well water, we recommend installing a filter on the inlet side to protect the pump from sand, gravel or other debris. If the pump is installed above the liquid level, we recommend that you fit a foot valve with a strainer to the inlet pipe.

Pipe system

To obtain the optimum suction capacity that the dry-installed pump is designed for, the correct dimension of the pipe system is important. If a hose is used as inlet pipe, it must be non-collapsible. The diameter of the inlet pipe must be larger than 1" if the inlet pipe is longer than 32.8 ft (10 m), or if the suction lift exceeds 13.1 ft (4 m).

To ensure optimum operation and longer life of the pump, a pressure tank with a properly set air charge should be installed in the system. See the tank manufacturer's instructions for proper tank size selection and specific setting of the air charge. See table below for general guidelines.

Pressure switch cut-on pressure [psi]	Tank air pre-charge (no water pressure) [psi]
20	18
30	28
40	38

Inlet-pipe length and suction lift

The length of the inlet pipe of self-priming pumps depends on the geodetic suction lift. The recommended maximum length of the inlet pipe according to the suction lift is shown in the figure below. The example shows that if the suction lift is 8.2 ft (2.5 m), the length of the inlet pipe must not exceed 82 ft (25 m).

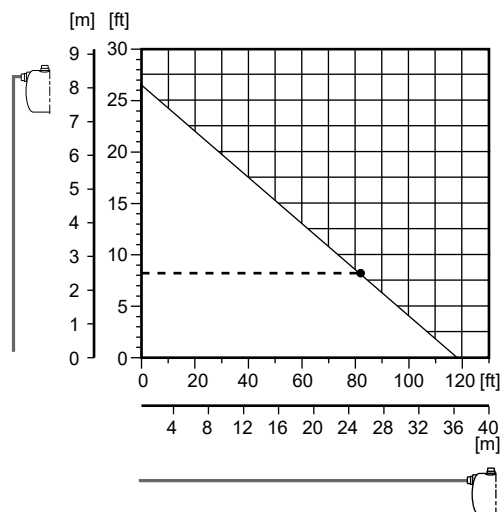

Maximum inlet-pipe length (horizontal axis) according to the suction lift (vertical axis)

Inlet and outlet pipes

The following are general considerations when connecting the inlet and outlet pipes:

- Install the pipes so that air pockets are avoided, especially on the inlet side of the pump.
- Use eccentric reducers with the tapered side down.
- Make sure the pipes are as straight as possible to avoid unnecessary bends and fittings. We recommend long-radius 90° pipe bends to decrease friction loss.
- Run the inlet pipe as direct as possible and, ideally, make sure the length is at least ten times the pipe diameter.
- If possible, run a horizontal inlet line. We recommend a gradual upward slope to pumps operating in suction-lift conditions, and a gradual downward slope to pumps operating in positive inlet-pressure conditions.
- A short pipe must be the same diameter as the inlet port or larger.
- A long pipe must be one or two sizes larger than the inlet port, depending on the length.

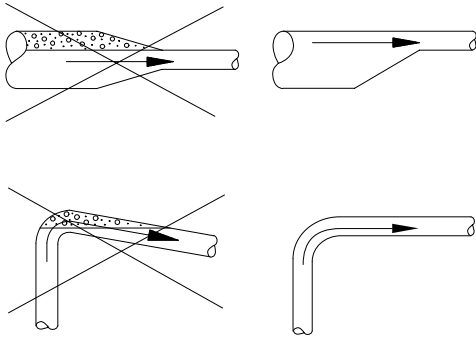

TM040338

Recommended pipe installation to avoid friction and air pockets

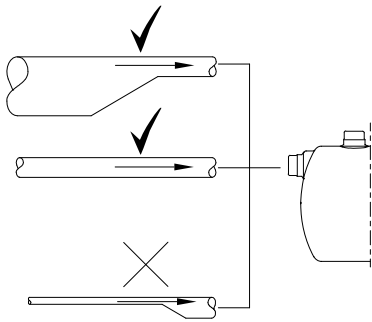

TM058227

Correct pipe sizing for connection to the pump inlet or outlet

Maximum system pressure



Make sure that the system in which the pump is installed is designed for the maximum pump pressure.

The maximum inlet pressure depends on the head at the actual duty point. The sum of the inlet pressure and the head must not exceed the maximum system pressure. We recommend installing a pressure-relief valve to protect the pump so that the outlet pressure does not exceed the maximum system pressure.

Installation examples

We recommend that you follow the installation examples.
Valves are not supplied with the pump.

Suction from a well (outdoor installation)

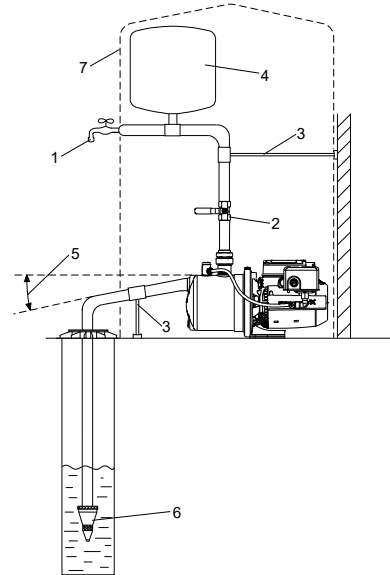

TM073984

Pos.	Description
1	Highest faucet
2	Isolating valve
3	Pipe support
4	Pressure tank
5	Slight downward slope
6	Foot valve with strainer. The foot valve is optional. We recommend using a foot valve with a JP PS installation.
7	Pump and tank cover

Suction from a tank

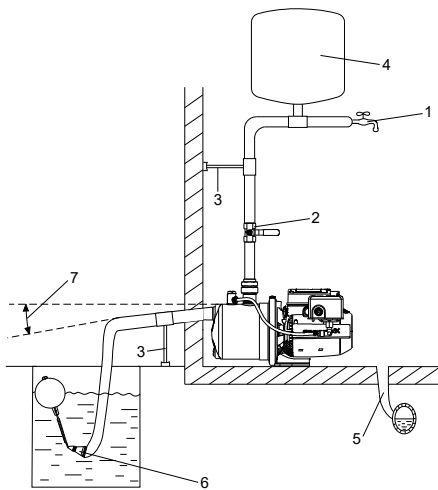

TM073986

Pos.	Description
1	Highest faucet
2	Isolating valve
3	Pipe support
4	Pressure tank
5	Drain to sewer
6	Strainer. A foot valve is optional. We recommend using a foot valve together with JP PS.
7	Slight downward slope

Electrical connection

The electrical connection and protection must be carried out in accordance with local regulations. Please also observe the following requirements:

- Make sure that the pump and pressure-control unit are suitable for the power supply to which they are to be connected.
- The pump and pressure-control unit must always be correctly grounded.
- The plug on the pump must have the same protective earth (PE) connection system as the power outlet. If not, use a suitable adapter if allowed by local regulations.
- A pump without plug must be connected to an external main switch or wired with a plug.

Motor protection

The pump incorporates current- and temperature-dependent motor protection. If the pump is running without water, is blocked or otherwise overloaded, the built-in thermal switch will cut out. When the motor has cooled sufficiently, it will restart automatically.

No external motor protection is required.

4. Selection

Selection guide

This guide helps you size and select your pump. Follow the instructions below.

Selection table

Selection table for JP PS, water supply on demand.

Model	1-5 taps/ 8.8-13.2 gpm/ (2-3 m ³ /h)	6-10 taps/ 13.2-17.6 gpm/ (3-4 m ³ /h)
JP PS 13 03 137	•	
JP PS 16 05 154*		•
JP PS 16 07 177*		•
JP PS 16 10 187*		•

* Selection depends on pressure needs.

How to use the selection table

Determine the model by selecting the rated flow either in a) the number of taps in the system, or b) in output in gallons per minute (or m³/h).

Related information

[How to read the curve charts](#)

[Curve charts, JP PS](#)

5. Performance curves

How to read the curve charts

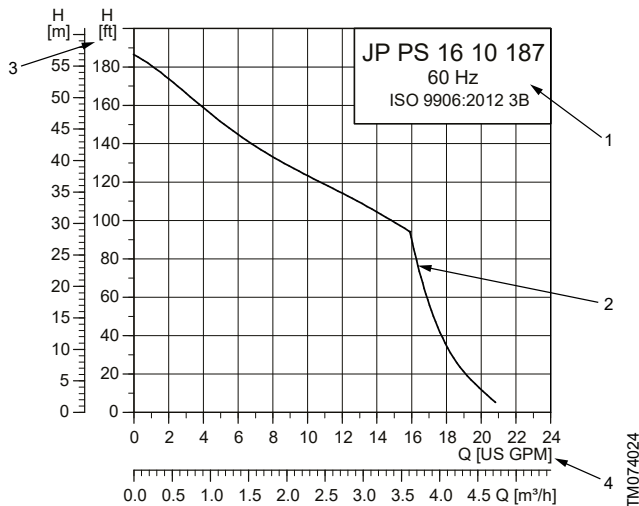

Pos.	Description
1	Pump type and frequency
2	Q-H curve for the pump; head (ft/m) to flow rate (gpm/m ³ /h)
3	[H] Head (ft/m)
4	[Q] flow rate (gpm/ m ³ /h)

The guidelines below apply to the following curves:

1. Standard motors are used for the measurements.
2. Measurements have been made with airless water at a temperature of 68 °F (20 °C).
3. The curves apply to a kinematic viscosity of $U = 1 \text{ mm}^2/\text{s}$ (1 cSt).
4. The QH curves apply to actual speed with the motor types mentioned at 60 Hz.

Related information

[Selection table](#)

Curve charts, JP PS

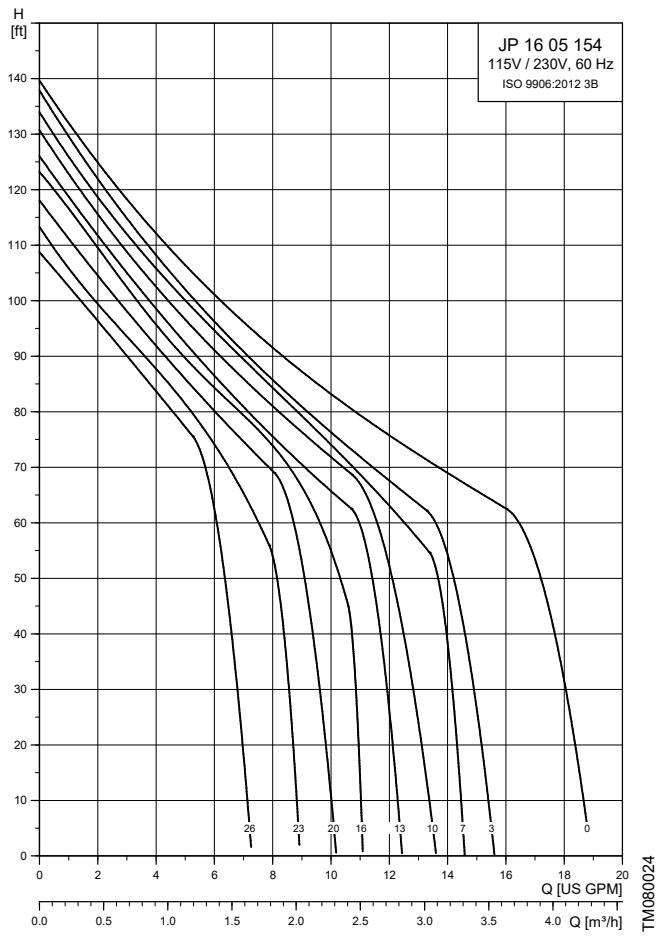
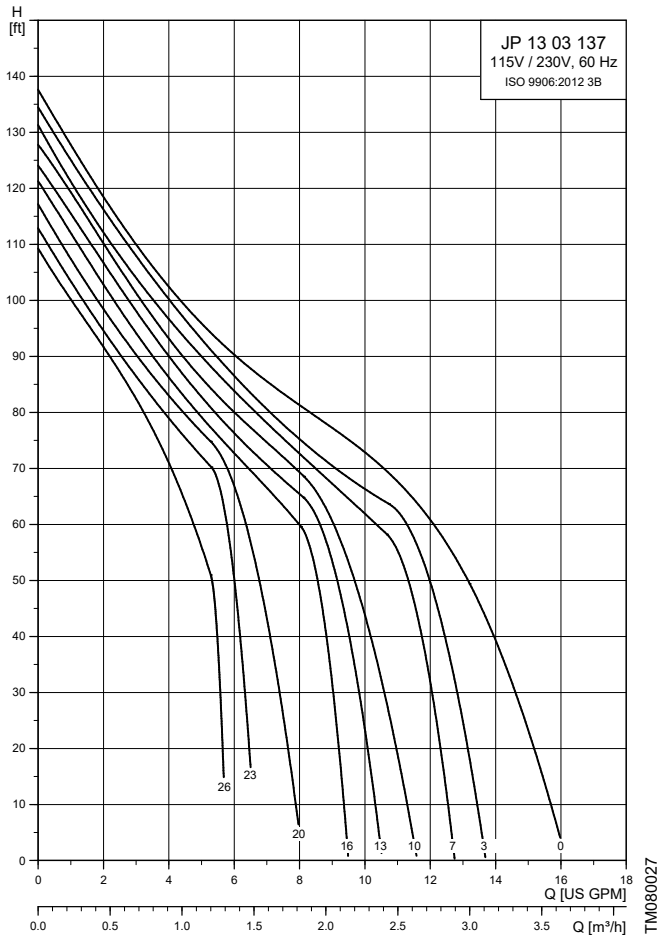

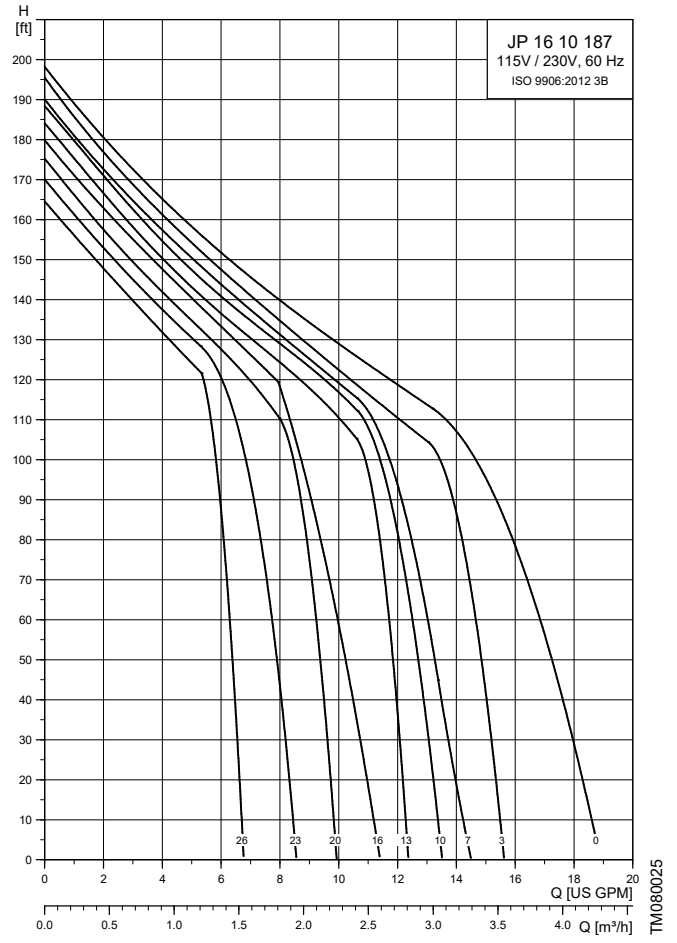
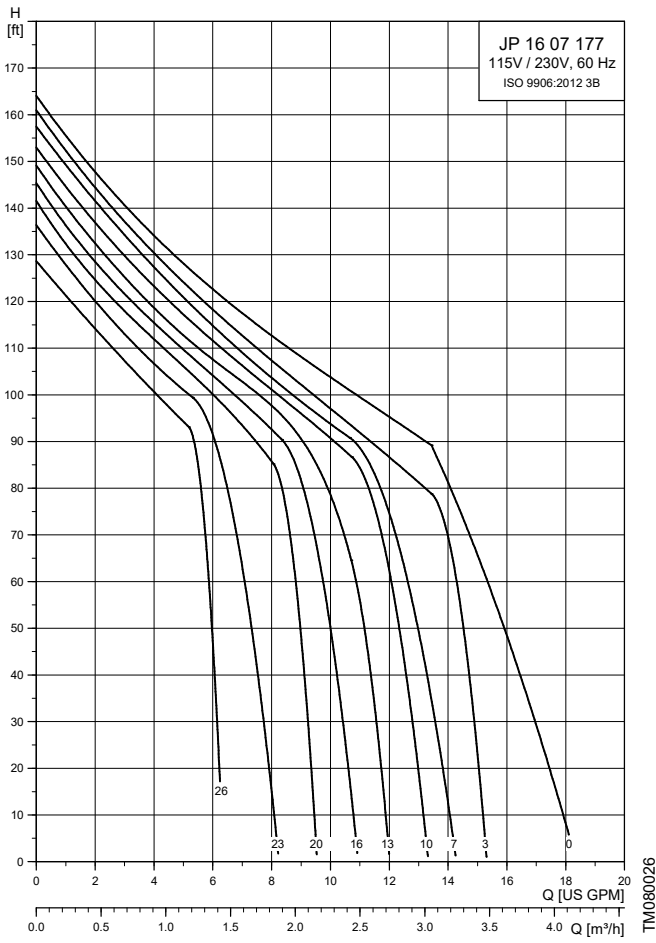

Related information

[Selection table](#)

6. Technical data

Dimensions and weights

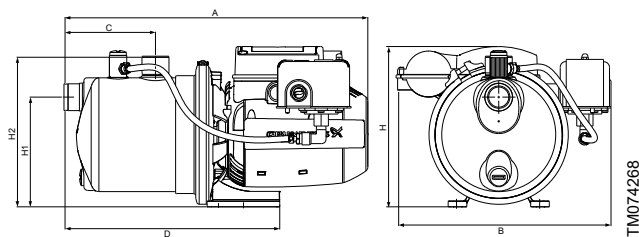

JP PS 13 03 137 and JP PS 16 05 154

Pos.	[in]	[mm]
A	15.9	403
B	11.23	285
C	4.77	121
D	11.30	287
H	8.23	209
H1	5.79	147
H2	7.88	200

JP PS 16 07 177 and JP PS 16 10 187

Pos.	[in]	[mm]
A	16.9	429
B	11.26	286
C	4.77	121
D	11.30	287
H	8.74	222
H1	5.83	148
H2	7.91	201

Weights

Model	Wt [lb]	Wt [kg]
JP PS 13 03 137	22.3	10.1
JP PS 16 05 154	23.4	10.6
JP PS 16 07 177	27.4	12.4
JP PS 16 10 187	31.1	14.1

Operating conditions

System pressure	Max. 87 psi (6 bar / 0.60 MPa)
Suction lift	Max. 26.25 ft (8 m), including inlet-pipe pressure loss at a liquid temperature of 68 °F (20 °C)
Liquid temperature	Max. 104 °F (40 °C) (S1) / 140 °F (60 °C) (S3*)
Ambient temperature	Max. 104 °F (40 °C) (S1) / 131 °F (55 °C) (S3*)
Relative humidity	Max. 98 %
Enclosure class	IP44

Insulation class	F
Supply voltage	1 x 115 V, 60 Hz 1 x 230 V, 60 Hz
Start/stop frequency	Max. 20 per hour
Sound pressure level	Max. sound pressure level of the pump: JP PS 13 03 137: 68 [dB(A)] JP PS 16 05 154: 70 [dB(A)] JP PS 16 07 177: 74 [dB(A)] JP PS 16 10 187: 81 [dB(A)]

* S3 means that the pump will run in intermittent operation to cool down the motor.

Product numbers

JP PS, 60 Hz

Dual voltage (115/230 V), direct wired.

NPT (F) internal thread.

Model	Product number
JP PS 13 03 137	99463938
JP PS 16 05 154	99463939
JP PS 16 07 177	99463940
JP PS 16 10 187	99463941

Related information

[Performance range](#)

[Product range](#)

Electrical data

Model	Voltage [V]	P1 [Hp (W)]	P2 [Hp (W)]	n [rpm]	I _n [A]	I _{start} [A]
JP PS 13 03 137	1 x 230	1 (750)	0.3 (250)	3400	3.3	11.26
	1 x 115	1 (750)	0.3 (250)	3400	6.5	22.35
JP PS 16 05 154	1 x 230	1.26 (930)	0.5 (330)	3400	4.2	12.50
	1 x 115	1.26 (930)	0.5 (330)	3400	8.2	26.30
JP PS 16 07 177	1 x 230	1.50 (1120)	0.75 (550)	3400	5.2	23.70
	1 x 115	1.50 (1120)	0.75 (550)	3400	10.3	47.54
JP PS 16 10 187	1 x 230	2 (1480)	1 (740)	3400	7.1	30.71
	1 x 115	2 (1480)	1 (740)	3400	13.8	59.50

Approvals and marks



7. Grundfos Product Center

Online search and sizing tool to help you make the right choice.

<https://product-selection.grundfos.com>

All the information you need in one place

Performance curves, technical specifications, pictures, dimensional drawings, motor curves, wiring diagrams, spare parts, service kits, 3D drawings, documents, system parts. Grundfos Product Center displays any recent and saved items, including complete projects, right on the main page.

Downloads

On the product pages, you can download installation and operating instructions, data booklets, service instructions, etc. in PDF format.

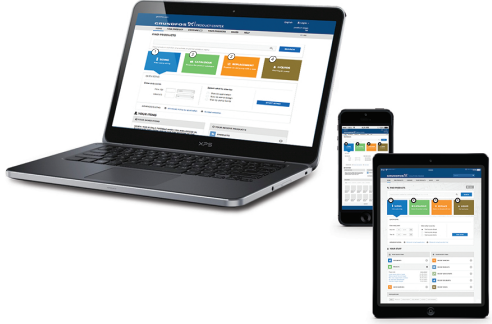

TM072384

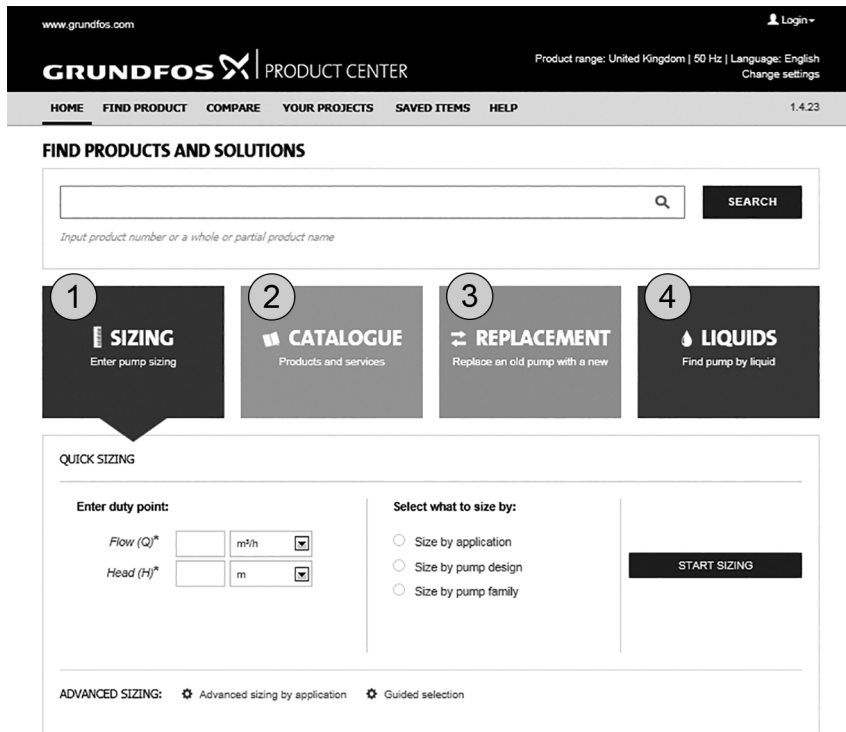

The screenshot shows the website header with the Grundfos logo and 'PRODUCT CENTER' text. Below the header is a navigation menu with options: HOME, FIND PRODUCT, COMPARE, YOUR PROJECTS, SAVED ITEMS, HELP. A search bar is present with a 'SEARCH' button. Below the search bar are four main navigation buttons: 1. SIZING (Enter pump sizing), 2. CATALOGUE (Products and services), 3. REPLACEMENT (Replace an old pump with a new), and 4. LIQUIDS (Find pump by liquid). Below these buttons is a 'QUICK SIZING' section with input fields for 'Flow (Q)*' (m³/h) and 'Head (H)*' (m), and radio buttons for 'Size by application', 'Size by pump design', and 'Size by pump family'. A 'START SIZING' button is located to the right of these options. At the bottom of the quick sizing section, there are links for 'ADVANCED SIZING' with sub-options for 'Advanced sizing by application' and 'Guided selection'.

TM070462

Pos.	Description
1	SIZING enables you to size a pump based on entered data and selection choices.
2	CATALOG gives you access to the Grundfos product catalog.
3	REPLACEMENT enables you to find a replacement product. <ul style="list-style-type: none"> • Search results will include information on • the lowest purchase price • the lowest energy consumption • the lowest total life cycle cost.
4	LIQUIDS enables you to find pumps designed for aggressive, flammable or other special liquids.

U.S.A.

Global Headquarters for WU
856 Koomey Road
Brookshire, Texas 77423 USA
Phone: +1-630-236-5500

GRUNDFOS CBS Inc.
902 Koomey Road
Brookshire, TX 77423 USA
Phone: 281-994-2700
Toll Free: 1-800-955-5847
Fax: 1-800-945-4777

GRUNDFOS Pumps Corporation
9300 Loiret Boulevard
Lenexa, Kansas 66219 USA
Tel.: +1 913 227 3400
Fax: +1 913 227 3500

Canada

GRUNDFOS Canada inc.
2941 Brighton Road
Oakville, Ontario
L6H 6C9
Tel.: +1-905 829 9533
Fax: +1-905 829 9512

Mexico

Bombas GRUNDFOS de México
S.A. de C.V.
Boulevard TLC No. 15
Parque industrial Stiva Aeropuerto
Apodaca, N.L. 66600
Tel.: +52-81-8144 4000
Fax: +52-81-8144 4010

Revision Info

Last revised on 04-2021

99599466 08.2021

ECM: 1321539

GRUNDFOS Holding A/S
Poul Due Jensens Vej 7
DK-8850 Bjerringbro
Tel: +45 87 50 14 00
www.grundfos.com

GRUNDFOS 