

LARGE DIAMETER

# Standard Vent Saw

DESIGNED FOR CUTTING ALL TYPES OF WOOD AND OTHER NONFERROUS MATERIALS, INCLUDING plywood, composition board and siding.

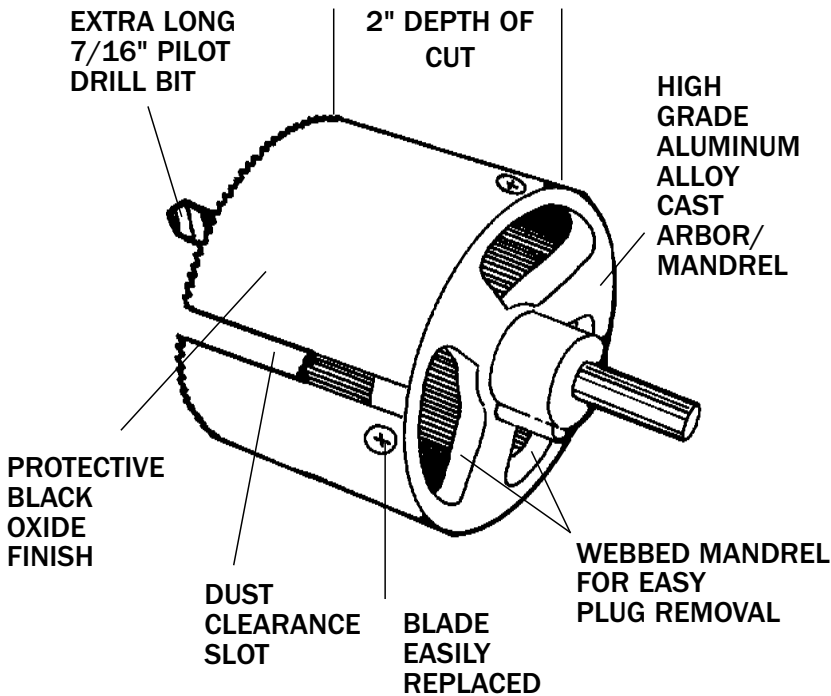

## OPERATING TIPS

PILOT DRILL IS PRE-INSTALLED IN VENT SAW. Drill bit point length extending beyond saw teeth is preset to accommodate hole cuts up to 2" deep. No further adjustment is necessary. Hold saw perpendicular to work when drilling pilot so that teeth engage evenly to assure accurate, efficient hole cutting. Keep a firm grip on drill and apply only moderate feed pressure while drilling pilot to maintain operator control when saw teeth engage material.

NOTE: Extra long pilot drill easily bores through nonferrous materials up to 4" thick. For some hole cutting applications, the extra pilot drill length may help locate the hole center from the other side of work in order to finish hole cuts up to a maximum 4" depth.

RECOMMENDED CUTTING SPEEDS WILL RANGE DEPENDING ON MATERIAL BEING CUT. Refer to drill manufacturer's use and care manual for recommended operating instructions and proper drill size. Generally, lower speeds should be used for hard, dense materials while higher speeds are more efficient when cutting in softer, less dense or thinner materials. For optimum performance and maximum blade life, operate Hole Saw at slowest speed and lowest feed pressure consistent with good results. Saw must be held perpendicular to the surface being cut. Cutting at an angle will result in blade damage.

REPLACEMENT BLADES: Blades are easily replaced by removing the 4 screws and lock nuts that hold blade to aluminum arbor. New replacement blades will come with a new set of screws and lock nuts. Place new blade over aluminum arbor and line up the holes in arbor with the holes in blades. Tighten screws securely using a 1/8" hex key wrench and 3/8" open or closed end wrench.

IDEAL FOR VENTING APPLICATIONS: Furnaces, Water Heaters, Kitchen and Bathroom Fans, Attic Vents, Cloths Dryers. Also used for installing fresh air intakes, water and sewer pipes, electrical boxes, lighting fixtures.

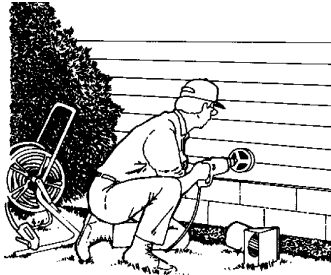

## SIZES:

### Large Diameter Standard Vent Saws

Catalog Number	Saw Diameter	Depth of Cut	Ctn. Wt. in LBS.
Inches	Inches		
HSW68	4-1/4 Dia.	2"	1.5
HSW97	6-1/4 Dia.	2"	2.0

### REPLACEMENT BLADES

RBW68	4-1/4 Dia.	2"	0.5
RBW97	6-1/4 Dia.	2"	0.9

### REPLACEMENT DRILL & EXTENSION

HSRD	Replacement Drill	0.3
HSX	13" Ext. -All Vent saws	.75

Distributed by: [BEST MATERIALS LLC](#)  
 Ph: 800-474-7570, 602-272-8128  
 Email: [sales@bestmaterials.com](mailto:sales@bestmaterials.com)  
[www.bestmaterials.com](http://www.bestmaterials.com)

**ALWAYS USE PROTECTIVE EYEWEAR.**