

DMH 25X

Dosing pump

Installation and operating instructions



DMH 25x
Installation and operating instructions
<http://net.grundfos.com/qr/i/99558949>

DMH 25X

English (GB)	
Installation and operating instructions	4
Čeština (CZ)	
Montážní a provozní návod	44
Deutsch (DE)	
Montage- und Betriebsanleitung	84
Español (ES)	
Instrucciones de instalación y funcionamiento	124
Français (FR)	
Notice d'installation et de fonctionnement	164
Ελληνικά (GR)	
Οδηγίες εγκατάστασης και λειτουργίας	204
Hrvatski (HR)	
Montažne i pogonske upute	245
Magyar (HU)	
Telepítési és üzemeltetési utasítás	285
Italiano (IT)	
Istruzioni di installazione e funzionamento	325
Nederlands (NL)	
Installatie- en bedieningsinstructies	365
Polski (PL)	
Instrukcja montażu i eksploatacji	405
Português (PT)	
Instruções de instalação e funcionamento	445
Română (RO)	
Instrucţiuni de instalare şi utilizare	485
Srpski (RS)	
Uputstvo za instalaciju i rad	525
Svenska (SE)	
Monterings- och driftsinstruktion	565
Slovensko (SI)	
Navodila za montažo in obratovanje	604
Türkçe (TR)	
Montaj ve kullanım kılavuzu	644
中文 (CN)	
安装和使用说明书	684
Appendix A	721
Appendix B	733

Original installation and operating instructions

Table of contents

1. General information	4	9. Operation	34
1.1 Introduction	4	9.1 Switching on/off.	34
1.2 Applications	4	9.2 Setting the dosing capacity.	34
2. Safety	5	9.3 Using the AR control unit (optional).	34
2.1 Identification of safety instructions in this manual	5	9.4 Electric servomotor (optional)	34
2.2 Qualification and training of personnel	5	9.5 Electronic preselection counter (optional)	34
2.3 Risks when safety instructions are not observed.	5	9.6 Electrically heated dosing head (optional)	34
2.4 Safety-conscious working.	5	10. Maintenance	35
2.5 Safety instructions for the operator/user.	5	10.1 General notes.	35
2.6 Safety instructions for maintenance, inspection and installation work	5	10.2 Diaphragm leakage control for diaphragm leakage detection	35
2.7 Unauthorised modification and manufacture of spare parts	6	10.3 Cleaning and maintenance intervals	35
2.8 Improper operating methods	6	10.4 Checking the oil level	35
2.9 Safety of the system in the event of a failure in the dosing system	6	10.5 Cleaning the suction and discharge valves	35
3. Technical data	6	10.6 Replacing the diaphragm and gear oil for dosing head with single diaphragm (no diaphragm leakage detection)	37
3.1 Identification.	6	10.7 Replacing the diaphragm for dosing head with double diaphragm	38
3.2 Pump models and pump types	9	11. Fault finding chart	41
3.3 Pump performance.	9	12. Dosing curves	43
3.4 Sound pressure level	11	13. Disposing of the product	43
3.5 Electrical data.	11		
3.6 AR control unit	11		
3.7 Power supply	12		
3.8 Ambient and operating conditions.	12		
3.9 Dosing medium.	12		
4. Transport and storage	13		
4.1 Delivery	13		
4.2 Unpacking	13		
4.3 Intermediate storage.	13		
4.4 Return	13		
5. Product description and accessories	14		
5.1 General description	14		
5.2 Dimensions	18		
5.3 Weight	22		
5.4 Stroke volume	22		
5.5 Materials.	22		
5.6 Data of contact pressure gauge for diaphragm leakage detection (optional)	22		
6. Installation	23		
6.1 General information on installation	23		
6.2 Installation location	23		
6.3 Mounting.	23		
6.4 Approximate values when using pulsation dampers.	23		
6.5 Optimum installation	25		
6.6 Installation tips	26		
6.7 Tube / pipe lines	27		
6.8 Connecting the suction and discharge lines.	27		
7. Electrical connections	28		
7.1 Electric servomotor (optional)	28		
7.2 Electronic preselection counter (optional)	28		
7.3 Electrically heated dosing head (optional).	28		
7.4 Diaphragm controller (optional)	29		
7.5 Connecting the power supply cable.	29		
8. Start-up/shutdown	30		
8.1 Initial start-up/subsequent start-up	30		
8.2 Start-up/subsequent start-up of DMH 251, 252 and 253	30		
8.3 Start-up/subsequent start-up of DMH 254, 255 and 257	31		
8.4 Setting the pressure relief valve	32		
8.5 Zero point adjustments	32		
8.6 Operating the pump	33		
8.7 Shutdown	33		

1. General information



Read this document before you install the product. Installation and operation must comply with local regulations and accepted codes of good practice.

1.1 Introduction

These installation and operating instructions contain all the information required for starting up and handling the DMH 25X piston diaphragm dosing pump.

If you require further information or if any problems arise, which are not described in detail in this manual, please contact the nearest Grundfos company.

1.2 Applications

The DMH 25X pump is suitable for liquid, non-abrasive and non-flammable media strictly in accordance with the instructions in this manual.

Explosion-proof pumps are identified from the pump and motor nameplates. An EC declaration of conformity is provided in accordance with the EC directive 2014/34/EU, the so-called ATEX directive. This declaration of conformity replaces the declaration of conformity in this manual.

Note

Warning



To operate a pump which has been identified as an explosion-proof pump for the dosing of inflammable media or for operation in potentially explosive operating sites in accordance with the EC directive 2014/34/EU, refer to the enclosed manual "ATEX-approved pumps" in addition to this manual.

Warning



Other applications or the operation of pumps in ambient and operating conditions, which are not approved, are considered improper and are not permitted. Grundfos accepts no liability for any damage resulting from incorrect use.

2. Safety

This manual contains general instructions that must be observed during installation, operation and maintenance of the pump. This manual must therefore be read by the installation engineer and the relevant qualified personnel/operators prior to installation and start-up, and must be available at the installation location of the pump at all times.

It is not only the general safety instructions given in this "Safety" section that must be observed, but all special safety instructions given in the other sections.

2.1 Identification of safety instructions in this manual

If the safety instructions or other advice in this manual are not observed, it may result in personal injury or malfunction and damage to the pump. The safety instructions and other advice are identified by the following symbols:



Warning

If these safety instructions are not observed, it may result in personal injury.

Caution

If these safety instructions are not observed, it may result in malfunction or damage to the equipment.

Note

Notes or instructions that make the job easier and ensure safe operation.

Information provided directly on the pump, e.g. labelling of fluid connections, must be maintained in a readable condition at all times.

2.2 Qualification and training of personnel

The personnel responsible for the operation, maintenance, inspection and installation must be appropriately qualified for these tasks. Areas of responsibility, levels of authority and the supervision of the personnel must be precisely defined by the operator.

If the personnel do not have the necessary knowledge, the necessary training and instruction must be given. If necessary, training can be performed by the manufacturer/supplier at the request of the operator of the pump. It is the responsibility of the operator to make sure that the contents of this manual are understood by the personnel.

2.3 Risks when safety instructions are not observed

Non-observance of the safety instructions may have dangerous consequences for the personnel, the environment and the pump. If the safety instructions are not observed, all rights to claims for damages may be lost.

Non-observance of the safety instructions may lead to the following hazards:

- failure of important functions of the pump/system
- failure of specified methods for maintenance
- harm to humans from exposure to electrical, mechanical and chemical influences
- damage to the environment from leakage of harmful substances.

2.4 Safety-conscious working

The safety instructions in this manual, applicable national health and safety regulations and any operator internal working, operating and safety regulations must be observed.

2.5 Safety instructions for the operator/user

Hazardous hot or cold parts on the pump must be protected to prevent accidental contact.

Leakages of dangerous substances (e.g. hot, toxic) must be disposed of in a way that is not harmful to the personnel or the environment. Legal regulations must be observed.

Damage caused by electrical energy must be prevented (for more details, see for example the regulations of the VDE and the local electricity supply company).

2.6 Safety instructions for maintenance, inspection and installation work

The operator must ensure that all maintenance, inspection and installation work is carried out by authorised and qualified personnel, who have been adequately trained by reading this manual.

All work on the pump should only be carried out when the pump is stopped. The procedure described in this manual for stopping the pump must be observed.

Pumps or pump units which are used for media that are harmful to health must be decontaminated.

All safety and protective equipment must be immediately restarted or put into operation once work is complete.

Observe the points described in the initial start-up section prior to subsequent start-up.

Warning

The pump must be installed in a position where it is easily accessible during operation and maintenance work.



Observe the flow direction of valves (indicated by an arrow on the valve)!

Only tighten plastic valves by hand.

Only use the prescribed line types!

Electrical connections must only be carried out by qualified personnel!

Warning

Make sure that the pump is suitable for the actual dosing medium!



Observe the chemical manufacturer's safety instructions when handling chemicals!

Do not operate the pump next to closed valves.

Warning

The pump housing, control unit and sensors must only be opened by personnel authorised by Grundfos!

Repairs must only be carried out by authorised and qualified personnel!



Wear protective clothing (gloves and goggles) when working on the dosing head, connections or lines!

Before removing the dosing head, valves and lines, empty any remaining medium in the dosing head into a drip tray by carefully unscrewing the suction valve.

Caution

The resistance of the parts that come into contact with the media depends on the media, media temperature and operating pressure. Ensure that parts in contact with the media are chemically resistant to the dosing medium under operating conditions!

2.7 Unauthorised modification and manufacture of spare parts

Modification or changes to the pump are only permitted following agreement with the manufacturer. Original spare parts and accessories authorised by the manufacturer are safe to use. Using other parts can result in liability for any resulting consequences.

2.8 Improper operating methods

The operational safety of the supplied pump is only ensured if it is used in accordance with section Technical data. The specified limit values must under no circumstances be exceeded.

Explosion-proof pumps are identified from the pump and motor nameplates. An EC declaration of conformity is provided in accordance with the EC directive 2014/34/EU, the so-called ATEX directive. This declaration of conformity replaces the declaration of conformity in this manual.

Note

Warning



To operate a pump which has been identified as an explosion-proof pump for the dosing of inflammable media or for operation in potentially explosive operating sites in accordance with the EC directive 2014/34/EU, refer to the enclosed manual "ATEX-approved pumps" in addition to this manual.

If the assumption is made that a safe operation is no longer possible, switch off the pump and protect it against unintentional operation.

This action should be taken

- if the pump has been damaged.
- if the pump no longer seems to be operational.
- if the pump has been stored for an extended period of time in poor conditions.

2.9 Safety of the system in the event of a failure in the dosing system

DMH 25X dosing pumps are designed according to the latest technologies and are carefully manufactured and tested. However, a failure may occur in the dosing system. Systems in which dosing pumps are installed must be designed in such a way that the safety of the entire system is still ensured following a failure of the dosing pump. Provide the relevant monitoring and control functions for this.

3. Technical data

3.1 Identification

3.1.1 Nameplate

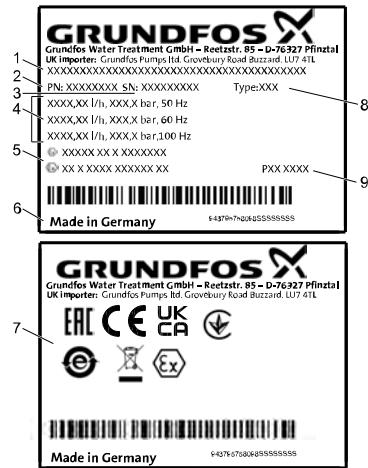

Pos.	Description
1	Type designation
2	Product number
3	Serial number
4	Pump performance by frequency
5	ATEX designation
6	Country of origin
7	Marks of approval
8	Pump model
9	Production code (year and week)

TM1040638

3.1.2 Type key

The type key is used to identify the precise pump and is not used for configuration purposes.

Type	
DMH1150-10D B-PVC/V/G-X-E1B8B8XEMAG	
Nominal dosing capacity [l/h]	
DMH1150-10D B-PVC/V/G-X-E1B8B8XEMAG	
Max. pressure [bar]	
DMH1150-10D B-PVC/V/G-X-E1B8B8XEMAG	
10D	Pumps marked with a "D" after the pressure value are double-head pumps.
Control variant	
DMH1150-10D B-PVC/V/G-X-E1B8B8XEMAG	
B	Standard (manual control)
S1	Stroke counter NAMUR, NC output
AR*	AR control unit, pump-mounted
AW*	AR control unit, wall-mounted
D3	Servomotor, 1AC 115-230 V, 50/60 Hz, 4-20 mA control (without manual operation)
D4	Servomotor, 24 VDC, 4-20 mA control (without manual operation)
D6	EX servomotor, 1AC 115-230 V, 50/60 Hz, 4-20 mA control, type EX II 2G Ex db IIB T4
D7	EX servomotor, 24 VDC, 4-20 mA control, type EX II 2G Ex db IIB T4
* Only for model 251, 252, 253	
Dosing head variant	
DMH1150-10D B-PVC/V/G-X-E1B8B8XEMAG	
PP	Polypropylene
PV	Polyvinylidene fluoride (PVDF)
SS	Stainless steel, 1.4571 (EN 10027-2), 316Ti (AISI)
PVC	Polyvinyl chloride
Y	Alloy C-4, 2.4610 (EN 10027-2)
PPL	PP with Diaphragm Leakage Detection (DLD)
PVL	PV with Diaphragm Leakage Detection (DLD)
SSL	SS with Diaphragm Leakage Detection (DLD)
PVCL	PVC with Diaphragm Leakage Detection (DLD)
YL	Y with Diaphragm Leakage Detection (DLD)
SSH	SS with electrically heated flange
SSHC	SS with liquid-heated flange
Gasket material	
DMH1150-10D B-PVC/V/G-X-E1B8B8XEMAG	
E	EPDM
V	FKM
T	PTFE

Valve ball material	
DMH1150-10D B-PVC/V/G-X-E1B8B8XEMAG	
G	Glass (from DN 32)
T	PTFE
SS	Stainless steel, 1.4401 (EN 10027-2), 316 (AISI)
C	Ceramic (up to DN 20)
Y	Alloy C-4, 2.4610 (EN 10027-2)

Terminal box position (also AR control or VFD position)

DMH1150-10D B-PVC/V/G-X-E1B8B8XEMAG	
X	Opposite side of dosing head (3 o'clock)
D	Towards dosing head (9 o'clock)
S	Towards adjusting knob (6 o'clock)
R	Opposite side of adjusting knob (12 o'clock)

Supply voltage

DMH1150-10D B-PVC/V/G-X-E1B8B8XEMAG	
E	3AC 230/400 V, 50/60 Hz, 440-480 V, 60 Hz (motors < 0.75 kW)
	3AC 230/400 V, 50 Hz, 460 V, 60 Hz (IE3, motors ≥ 0.75 kW)
G	1AC 230 V, 50/60 Hz (motors ≤ 0.09 kW)
	1AC 230 V, 50 Hz (motors 0.18 - 0.37 kW)
H	1AC 115 V, 50/60 Hz (motors ≤ 0.09 kW)
	1AC 115 V, 60 Hz (motors 0.18 - 0.37 kW)
F	Without motor, NEMA flange
0	Without motor, IEC flange
4	3AC 230/400 V, 50 Hz (EX motors)
5	3AC 220/380 V, 60 Hz (EX motors)
	3AC 220/380 V, 60 Hz, 440 V, 60 Hz (IE3, motors ≥ 0.75 kW)
K	3AC 500 V, 50 Hz
L	3AC 240/415 V, 50 Hz
P	3AC 240/415 V, 60 Hz
N	3AC 255/440 V, 60 Hz
M	3AC 400/690 V, 50 Hz (standard in power plants)

Valve type (inlet/outlet)

DMH1150-10D B-PVC/V/G-X-E1B8B8XEMAG	
1	Standard valves, not spring-loaded
3	Spring-loaded inlet valve (0.05 bar) and outlet valve (0.8 bar)
4	Spring-loaded outlet valve (0.8 bar), inlet valve not spring-loaded
5	For abrasive media
7	Not spring-loaded, inlet valve larger than outlet valve

Hydraulic connections (first = outlet, second = inlet)

DMH1150-10D B-PVC/V/G-X-E1B8B8XEMAG	
U2	G 5/8, for hoses 4/6 mm, 6/9 mm, 6/12 mm, 9/12 mm (PVC, PP, PVDF)
A	G 5/8, for pipes with internal thread Rp 1/4 (SS, Y)
U3	G 5/4, for hoses with internal diameter 19 or 20 mm and for pipes with external diameter 25 mm
U7	G 5/8, for hoses 0.17" × 1/4", 1/4" × 3/8", 3/8" × 1/2" (PVC, PP, PVDF)
A1**	G 5/4, for pipes with internal thread Rp 3/4 (SS, Y)

Hydraulic connections (first = outlet, second = inlet)

A8	Flange DN 32, for pipes with internal thread 1 1/4 NPT (PVC, PP, PVDF)
B8	Flange DN 32, for pipes with external diameter 40 mm (PVC)
B5	Flange DN 32, for pipes with external diameter 40 mm (PP, PVDF)
C1	Flange DN 32, for welding 1 1/4" pipes, EN 1092-1 (SS)
V	G 5/8, for pipes with internal thread 1/4 NPT (SS)
A9	G 5/8, for pipes with external thread 1/2 NPT (PVC, PVDF)
A3	G 5/4, for pipes with internal thread 3/4 NPT (SS)
A7	G 5/4, for pipes with external thread 3/4 NPT (PVC, PVDF)
P	Prepared for ANSI Flange 1 1/4"

** Not for inlet side of DMH 550-10 and DMH 270-10 with PTC. They have a flange DN 32 on inlet side.

Mains plug (only 1AC motors)

DMH1150-10D B-PVC/V/G-X-E1B8B8XEMAG

X	No plug
F	EU (Schuko)
B	USA, Canada
I	Australia, New Zealand, Taiwan
E	Switzerland

Motor variant and certification

DMH1150-10D B-PVC/V/G-X-E1B8B8XEMAG

EM	Standard motor (without certificates)
E0	Motor with PTC for thermal protection (without certificates)
E1	EX motor, type EX II 2G EEx e II T3 (without certificates)
E2	EX motor, type EX II 2GD EEx de IIC T4, without PTC (without certificates)
E3	Pump with API approval (without pump and motor certificates)
E5	EX motor, type EX II 2GD EEx de IIC T4, with PTC (without certificates)
FA	VFD (variable frequency drive) (without certificates)
FB	VFD with I/O extension board (without certificates)
FC	VFD with internal Profibus (without certificates)
MP	Standard motor (with certificates)
K0	Motor with PTC for thermal protection (with certificates)
K1	EX motor, type EX II 2G EEx e II T3 (with certificates)
K2	EX motor, type EX II 2GD EEx de IIC T4, without PTC (with certificates)
K3	Pump with API approval (with pump and motor certificates)
K5	EX motor, type EX II 2GD EEx de IIC T4, with PTC (with certificates)

Pump housing material

DMH1150-10D B-PVC/V/G-X-E1B8B8XEMAG

A	Aluminium
C	Grey cast iron

Pump design

DMH1150-10D B-PVC/V/G-X-E1B8B8XEMAG

G	Grundfos
N	Neutral

3.2 Pump models and pump types

The DMH 25X dosing pump is available for a variety of performance ranges in various sizes. The pump nameplate shows various data of the pump like the type designation and the pump model. For an explanation of the nameplate see section Nameplate.

The pump type is the left part of the type designation and consists of the type abbreviation, the nominal dosing flow and the maximum counterpressure. For an explanation of the type designation see section Type Key.

The motor nameplate shows various electrical data.

Related information

[3.1.1 Nameplate](#)

[3.1.2 Type key](#)

3.3 Pump performance

3.3.1 Performance data at maximum counterpressure

Pump model	Pump type	50 Hz			60 Hz			100 Hz		
		Q ¹	p max. ²	Max. stroke rate	Q ¹	p max. ²	Max. stroke rate	Q ¹	p max. ²	Max. stroke rate
		[l/h]	[bar]	[n/min]	[l/h]	[bar]	[n/min]	[l/h]	[bar]	[n/min]
DMH 251	DMH 2,2-25	2,2	25	14	2,6	25	17	4,4	25	29
	DMH 2,3-16	2,3	16	14	2,8	16	17	4,5	16	29
	DMH 2,4-10	2,4	10	14	2,9	10	17	5	10	29
	DMH 4,5-25	4,5	25	29	5,4	25	35	9	25	58
	DMH 4,9-16	4,9	16	29	5,9	16	35	9,8	16	58
	DMH 5-10	5	10	29	6	10	35	10	10	58
	DMH 11-25	11	25	63	13	25	75	22	25	126
	DMH 12-16	12	16	63	14	16	75	24	16	126
	DMH 13-10	13	10	63	16	10	75	25	10	126
	DMH 17-25	17	25	96	20	25	115	-	-	-
	DMH 18-16	18	16	96	22	16	115	-	-	-
	DMH 19-10	19	10	96	23	10	115	-	-	-
	DMH 21-25	21	25	120	-	-	-	-	-	-
	DMH 23-16	23	16	120	-	-	-	-	-	-
DMH 24-10	24	10	120	-	-	-	-	-	-	
DMH 252	DMH 10-16	10	16	29	12	16	35	20	16	58
	DMH 11-10	11	10	29	13	10	35	22	10	58
	DMH 23-16	23	16	63	27	16	75	46	16	126
	DMH 24-10	24	10	63	29	10	75	48	10	126
	DMH 36-16	36	16	96	43	16	115	-	-	-
	DMH 37-10	37	10	96	44	10	115	-	-	-
	DMH 45-16	45	16	120	54	16	144	-	-	-
	DMH 46-10	46	10	120	-	-	-	-	-	-
DMH 54-16	54	16	144	-	-	-	-	-	-	
DMH 253	DMH 21-10	21	10	29	25	10	35	46	10	58
	DMH 43-10	43	10	63	52	10	75	87	10	126
	DMH 67-10	67	10	96	78	10	115	-	-	-
	DMH 83-10	83	10	120	99	10	144	-	-	-
	DMH 100-10	100	10	144	-	-	-	-	-	-

Pump model	Pump type	50 Hz			60 Hz			100 Hz		
		Q ¹	p max. ²	Max. stroke rate	Q ¹	p max. ²	Max. stroke rate	Q ¹	p max. ²	Max. stroke rate
		[l/h]	[bar]	[n/min]	[l/h]	[bar]	[n/min]	[l/h]	[bar]	[n/min]
DMH 254	DMH 50-10	50	10	26	60	10	31	101	10	52
	DMH 97-16	97	16	54	116	16	65	193	16	108
	DMH 102-10	102	10	54	122	10	65	203	10	108
	DMH 136-16	136	16	75	163	16	90	271	16	150
	DMH 143-10	143	10	75	172	10	90	286	10	150
	DMH 166-16	166	16	92	200	16	110	-	-	-
	DMH 175-10	175	10	92	210	10	110	-	-	-
	DMH 202-16	202	16	112	242	16	134	-	-	-
	DMH 213-10	213	10	112	255	10	134	-	-	-
	DMH 276-16	276	16	153	-	-	-	-	-	-
DMH 291-10	291	10	153	-	-	-	-	-	-	
DMH 255	DMH 194-10	194	10	54	233	10	65	387	10	108
	DMH 270-10	270	10	75	324	10	90	540	10	150
	DMH 332-10	332	10	92	398	10	110	-	-	-
	DMH 403-10	403	10	112	484	10	134	-	-	-
	DMH 550-10	550	10	153	-	-	-	-	-	-
DMH 257	DMH 272-16	272	16	56	326	16	67	544	16	112
	DMH 340-16	340	16	73	408	16	88	680	16	146
	DMH 440-10	440	10	56	528	10	67	880	10	112
	DMH 450-16	450	16	98	540	16	118	-	-	-
	DMH 520-16	520	16	112	624	16	134	-	-	-
	DMH 575-10	575	10	73	690	10	88	1150	10	146
	DMH 680-16	680	16	146	-	-	-	-	-	-
	DMH 750-4	750	4	73	900	4	88	1500	4	146
	DMH 770-10	770	10	98	924	10	118	-	-	-
	DMH 880-10	880	10	112	1056	10	134	-	-	-
DMH 1150-10	1150	10	146	-	-	-	-	-	-	
DMH 1500-4	1500	4	146	-	-	-	-	-	-	

¹ Dosing capacity per dosing head; double the capacity for double-head pumps.

² Maximum counterpressure

Note The pump can be operated in the range between 10 % and 100 % of the maximum dosing capacity.

3.3.2 Accuracy

- Dosing flow fluctuation: smaller than $\pm 1,5$ % within the control range 10-100 %
- Linearity deviation: ± 2 % of the full-scale value.

Applies to:

- water as dosing medium
- fully deaerated dosing head
- standard pump version.

3.3.3 Maximum inlet pressure

Pump model	[bar]
DMH 251	8
DMH 252	8
DMH 253	5
DMH 254	5
DMH 255	0,8
DMH 257	0,8

3.3.4 Minimum counterpressure at the discharge valve of the pump

Pump model	[bar]
All	2

Note A positive pressure difference of at least 2 bar is required between the suction valve and the discharge valve in order for the dosing pump to operate correctly. If the total counter-pressure (at the dosing point) and geodetic height difference between the suction valve and the dosing point is less than 2 bar (20 m WC), a pressure-loading valve must be installed immediately before the dosing point.

3.3.5 Maximum suction lift* (continuous operation) for media with a viscosity similar to water

Pump model	Pump type	Maximum suction lift [m WC]
DMH 251	All	1
DMH 252	All	1
DMH 253	DMH 21-10	1
	DMH 43-10	1
	DMH 67-10	1
	DMH 83-10	1
	DMH 100-10	Flooded suction
DMH 254	DMH 50-10	1
	DMH 97-16	1
	DMH 102-10	1
	DMH 136-16	1
	DMH 143-10	1
	DMH 166-16	1
	DMH 175-10	1
	DMH 202-16	1
	DMH 213-10	1
	DMH 276-16	Flooded suction
DMH 291-10	Flooded suction	
DMH 255	All	Flooded suction
DMH 257	DMH 272-16	1
	DMH 340-16	Flooded suction
	DMH 440-10	1
	DMH 450-16	Flooded suction
	DMH 520-16	Flooded suction
	DMH 575-10	Flooded suction
	DMH 680-16	Flooded suction
	DMH 750-4	Flooded suction
	DMH 770-10	Flooded suction
	DMH 880-10	Flooded suction
DMH 1150-10	Flooded suction	
	DMH 1500-4	Flooded suction

* Applies to a filled dosing head.

3.3.6 Maximum suction lift (continuous operation) for media with maximum permissible viscosity

For maximum permissible viscosity see section Dosing medium.

Pump model	Maximum suction lift [m WC]
All	Flooded suction

Related information

[3.9 Dosing medium](#)

3.4 Sound pressure level

Pump model	dB(A) ¹
DMH 251	55 ± 5
DMH 252	55 ± 5
DMH 253	65 ± 5
DMH 254	65 ± 5
DMH 255	75 ± 5
DMH 257	75 ± 5

¹ Testing according to DIN 45635-01-KL3.

3.5 Electrical data

3.5.1 Enclosure class

The enclosure class depends on the motor variant selected, see motor nameplate.

The specified enclosure class can only be ensured if the power supply cable is connected with the same degree of protection.

Pumps with electronics: The enclosure class is only met if the sockets are protected! The data regarding the enclosure class applies to pumps with correctly inserted plugs or screwed-on caps.

3.5.2 Motor

Version: see motor and pump nameplates.

3.6 AR control unit

Functions of pumps with electronics:

- "Continuous operation" button for function test and dosing head deaeration
- memory function (stores a maximum of 65,000 pulses)
- two-stage tank-empty signal (e.g. via Grundfos tank empty sensor)
- stroke signal/pre-empty signal (adjustable), e.g. as a feedback to the control room
- dosing controller function (only with sensor - optional)
- diaphragm leakage detection (only with sensor - optional)
- access-code-protected settings
- remote on/off
- hall sensor
- operating hours counter
- motor monitoring.

Operating modes:

- manual
Stroke frequency: manually adjustable between zero and maximum
- contact signal control
Multiplier (1:n) and divisor (n:1)
- current signal control 0-20 mA / 4-20 mA
Adjustment of stroke frequency proportional to the current signal.
Weighting of current input.

3.6.1 Inputs and outputs

Inputs	
Contact signal	Maximum load: 12 V, 5 mA
Current 0-20 mA	Maximum load: 22 Ω
Remote on/off	Maximum load: 12 V, 5 mA
Two-stage tank-empty signal	Maximum load: 12 V, 5 mA
Dosing controller and diaphragm leakage sensor	
Outputs	
Current 0-20 mA	Maximum load: 350 Ω
Error signal	Maximum ohmic load: 50 VDC / 75 VAC, 0.5 A
Stroke signal	Contact time/stroke: 200 ms
Pre-empty signal	Maximum ohmic load: 50 VDC / 75 VAC, 0.5 A

AR control unit factory settings

- Inputs and outputs: NO (normally open)
or
- inputs and outputs: NC (normally closed).

3.7 Power supply

Power supply for AC voltage

Rated voltage	Permissible deviation from rated value
230 / 400 V	± 10 %
240 / 415 V	± 10 %
115 V	± 10 %

Maximum permissible mains impedance

(0.084 + j 0.084) Ohm (testing according to DIN EN 61000-3-11).
These details apply to 50 Hz.

3.8 Ambient and operating conditions

- Permissible air humidity: max. relative humidity: 70 % at +40 °C, 90 % at +35 °C.

Caution The installation site must be under cover!
Do not install outdoors!

3.8.1 DMH with motor labelled for coolant temperature -20 °C ≤ T_{amb} ≤ 40 °C

- Permissible ambient temperature: 0 °C (standard) to +40 °C (for an installation height up to 1000 m above sea level)
- Pumps with minimum T_{amb} -20 °C available on request
- Permissible storage temperature: -20 °C to +50 °C.

3.8.2 DMH with motor labelled for coolant temperature -20 °C ≤ T_{amb} ≤ 55 °C and with dosing head material stainless steel or PVDF

- Permissible ambient temperature: 0 °C (standard) to +55 °C (for an installation height up to 1000 m above sea level)
- Pumps with minimum T_{amb} -20 °C available on request
- Permissible storage temperature: -20 °C to +55 °C.

Note Observe the nameplate of the motor.

3.9 Dosing medium

Note In the event of questions regarding the material resistance and suitability of the pump for specific dosing media, please contact Grundfos.

The dosing medium must have the following basic characteristics for the standard pumps:

- liquid
- non-abrasive

The dosing of abrasive media is possible with certain versions, on request.

- non-flammable

The dosing of inflammable media is possible with certain versions of explosion-proof pumps, in accordance with ATEX.

Maximum permissible viscosity at operating temperature

Applies to:

- Newtonian liquids
- non-degassing media
- media without suspended matter
- media with a density similar to water.

Note Note that the viscosity increases with decreasing temperature!

Pump model	Up to stroke rate 63	Stroke rate 64-120	From stroke rate 121
	[n/min]	[n/min]	[n/min]
Maximum viscosity ¹ [mPa s]			
DMH 251	300	100	50
DMH 252	300	100	50
DMH 253	300	100	10
DMH 254	300	100	5
DMH 255	200	100	5
DMH 257	200	50	5

¹ The stated values are approximate values and apply to the standard pumps.

Permissible media temperature

Dosing head material	Min. media temperature	Max. media temperature		
		p < 10 bar	p < 16 bar	p < 25 bar
	[°C]	[°C]	[°C]	[°C]
PVC	0	40	20	-
Stainless steel, DIN 1.4571 ¹	-10	90	90	90
Alloy C-4, 2.4610 ¹	-10	90	90	90
PP	0	40	20	-
PVDF ²	-10	60	20	-

¹ For SIP/CIP applications (not with ATEX): A temperature of 145 °C at a counter-pressure of max. 2 bar is permitted for a short period (15 minutes).

² At 70 °C, the maximum counter-pressure is 9 bar.



Warning

Observe the chemical manufacturer's safety instructions when handling chemicals!

The dosing medium must be in liquid form!

Observe the freezing and boiling points of the dosing medium!

The resistance of the parts that come into contact with the media depends on the media, media temperature and operating pressure. Ensure that parts in contact with the media are chemically resistant to the dosing medium under operating conditions!

Make sure that the pump is suitable for the actual dosing medium!

Caution

4. Transport and storage

Do not throw or drop the pump.

Caution Do not use the protective packaging as transport packaging.

4.1 Delivery

The DMH 25X dosing pumps are supplied in different packaging, depending on pump type and the overall delivery. For transport and intermediate storage, use the correct packaging to protect the pump against damage.

4.2 Unpacking

Retain the packaging for future storage or return, or dispose of the packaging in accordance with local regulations.

4.3 Intermediate storage

See section Ambient and operating conditions.

Related information

[3.8 Ambient and operating conditions](#)

4.4 Return

The pump must be thoroughly cleaned before it is returned or stored. It is essential that there are no traces of toxic or hazardous media remaining on the pump. Drain the oil from the drive mechanism and package the pump correctly.

Caution Grundfos accepts no liability for damage caused by incorrect transportation, missing or unsuitable packaging of the pump, residual media or leaking oil!

Before returning the pump to Grundfos Water Treatment for service, the **safety declaration** at the end of these instructions must be filled in by authorised personnel and attached to the pump in a visible position.

Caution If a pump has been used for a medium which is injurious to health or toxic, the pump will be classified as contaminated.

If Grundfos Water Treatment is requested to service the pump, it must be ensured that the pump is free from substances that can be injurious to health or toxic. If the pump has been used for such substances, the pump must be cleaned before it is returned.

If proper cleaning is not possible, all relevant information about the chemical must be provided.

If the above is not fulfilled, Grundfos Water Treatment can refuse to accept the pump for service. Possible costs of returning the pump are paid by the customer.

The safety declaration can be found at the end of these instructions.

Caution The replacement of the power supply cable must be carried out by an authorised Grundfos service workshop.

5. Product description and accessories

5.1 General description

The DMH 25X are positive-displacement pumps with hydraulic diaphragm control. The operation procedure of the dosing pump is shown in the sectional drawing. See figures below.

The rotational movement of the motor (1p) is converted via the worm gear (2p) and eccentric (3p) into the reciprocating movement of the piston (6p). The piston has a hollow bore and a row of radial control holes, which provide a hydraulic connection between the drive area and the piston stroke area. The sliding sleeve (5p) covers the control holes during the stroke and seals the stroke area from the drive area.

The hydraulic-driven movement of the PTFE diaphragm (Q) displaces an equivalent volume of dosing medium from the dosing head (2) into the dosing line. With the suction stroke, the piston creates a low pressure, which is established in the dosing head. The ball valve (3b) on the dosing side closes and the dosing medium flows through the suction valve (3a) into the dosing head.

The stroke volume size is determined by the position of the sliding sleeve. The active stroke length and corresponding average dosing flow can be changed continuously and linearly from 10 % to 100 % using the stroke-length adjustment knob and Verner scale (L).

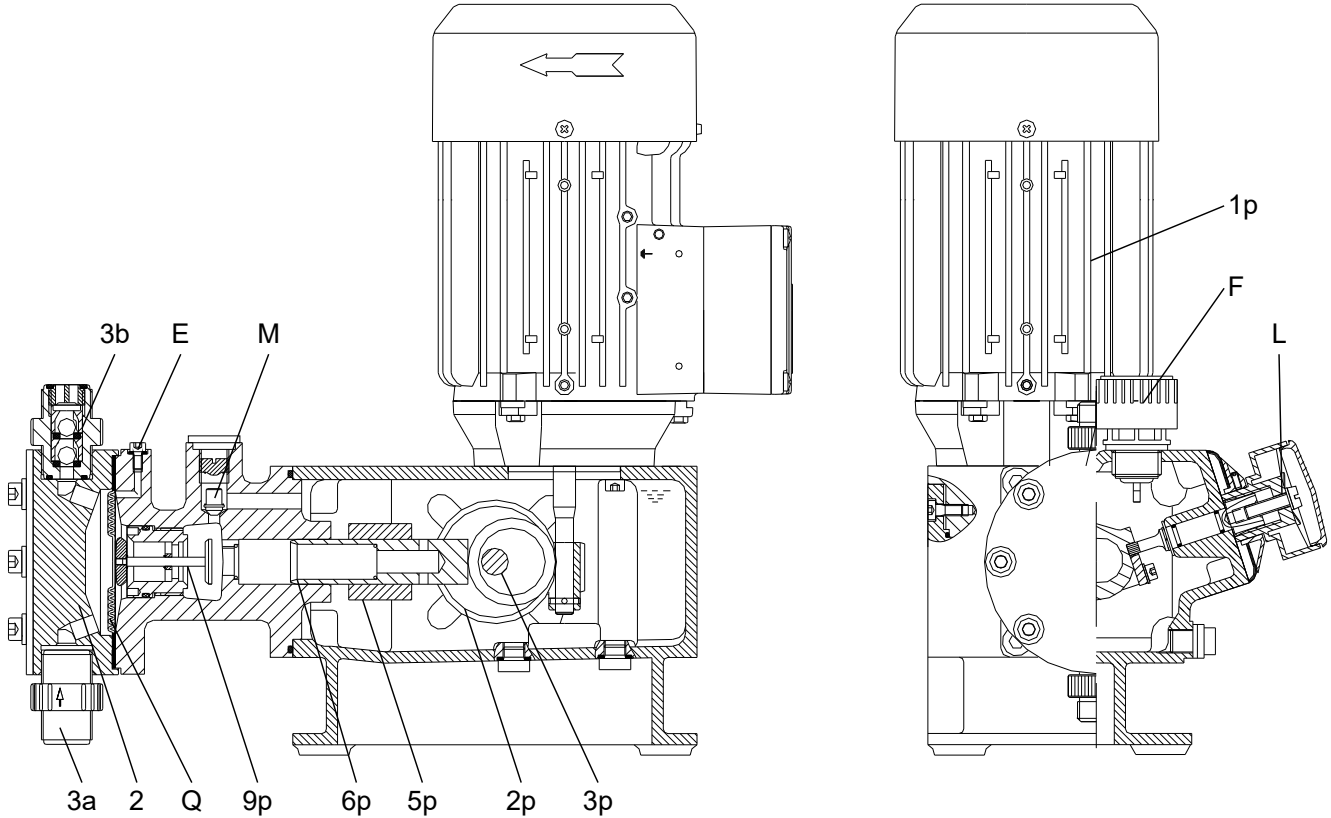

DMH 251, 252

TM036448

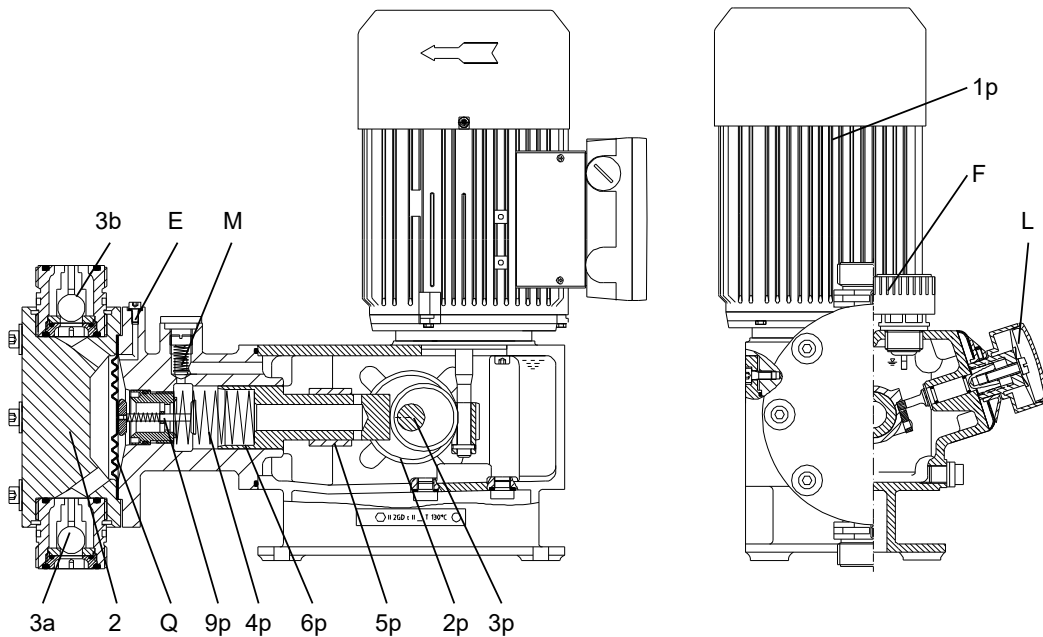

DMH 253

TM036449

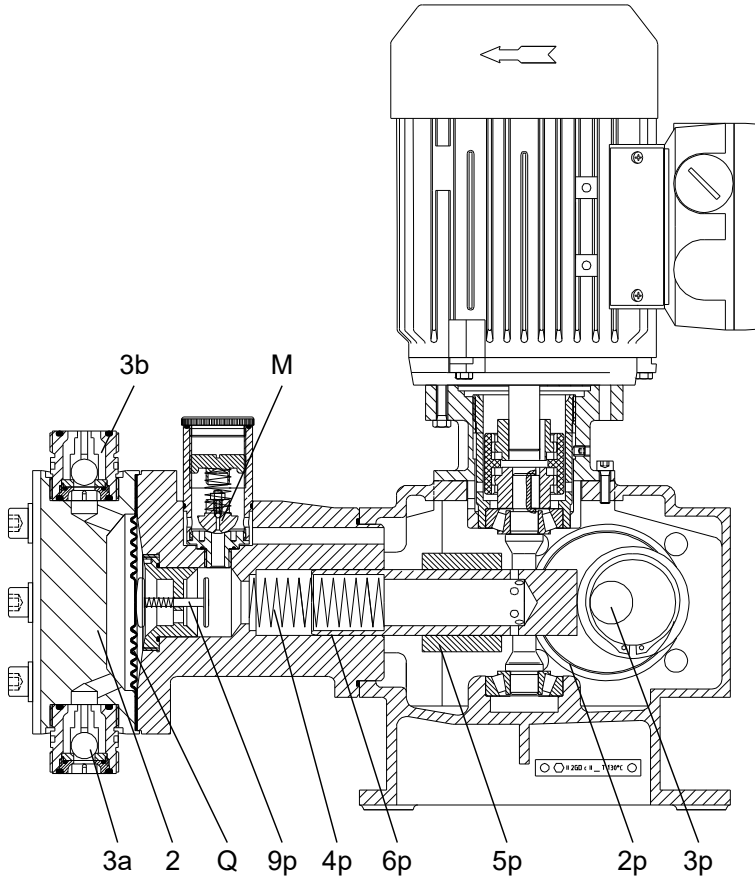

DMH 254

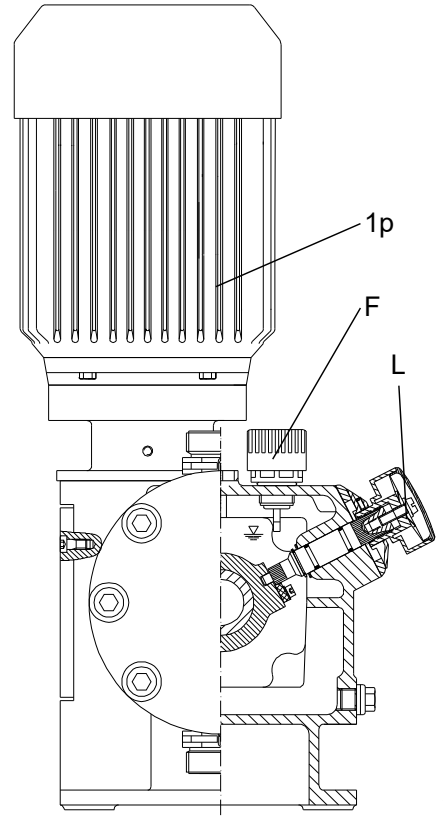

TM036450

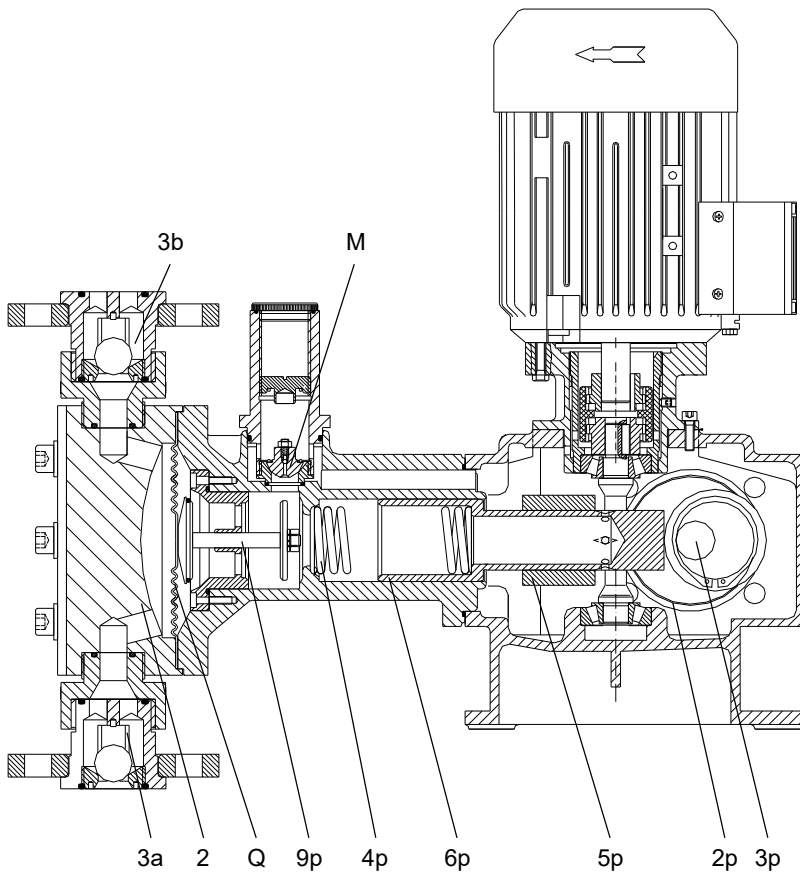

DMH 255

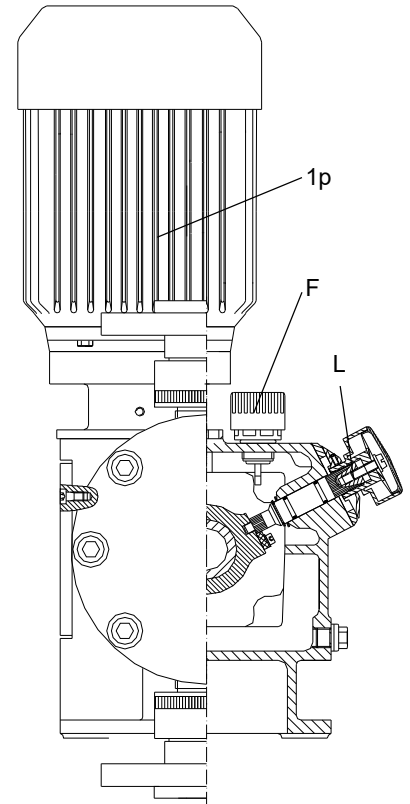

TM036451

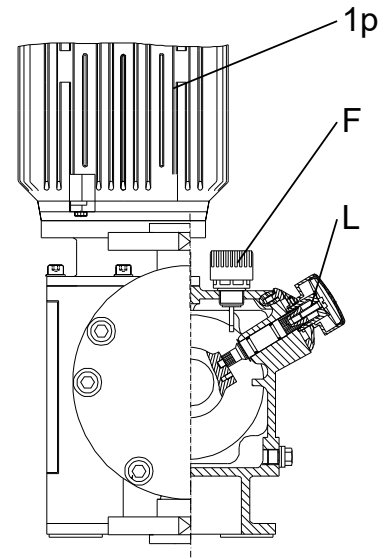
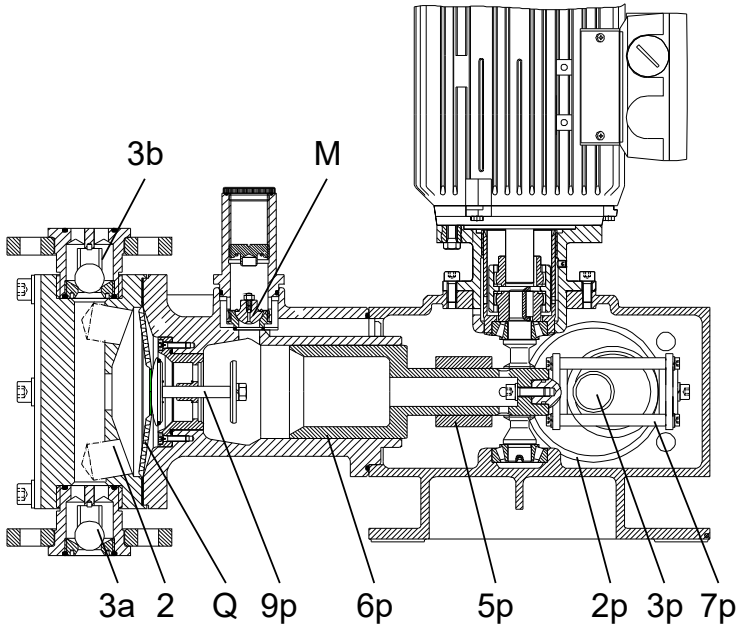

TM036452

DMH 257

Pos.	Components
1p	Motor
2p	Worm gear
3p	Eccentric
4p	Return spring (not with drive size 3)
5p	Sliding sleeve
6p	Piston
7p	Crank
M	Combined pressure-relief and degassing valve
E	Degassing valve
9p	Diaphragm protection system (AMS)
Q	Dosing diaphragm
2	Dosing head
3a	Suction valve
3b	Discharge valve
L	Stroke-length adjustment knob
F	Oil-filling screw with dipstick

5.1.1 Combined pressure-relief and degassing valve

The combined pressure-relief and degassing valve (M) opens if there is an excessive pressure build-up in the dosing system and provokes the constant degassing of the hydraulic medium.

5.1.2 Diaphragm protection system AMS

The diaphragm protection system AMS (9p) has a keypad, which is connected to the dosing diaphragm. The dosing diaphragm oscillates freely in the dosing head and cannot be overstretched due to a fault in the dosing system since the diaphragm protection valve closes if such a fault occurs.

5.1.3 Double-diaphragm system/diaphragm leakage detection (optional)

General

The piston diaphragm and high-tech dosing pumps with drift-free diaphragm leakage detection are equipped with the following:

- dosing head with PTFE double-diaphragm system
- ball non-return valve with built-in contact pressure gauge.

Double-diaphragm system

Dosing pumps with a double-diaphragm system with no diaphragm leakage detection have no pressure gauge. In this case the ball non-return valve is fitted with a locking unit. The valve, however, can be retrofitted with a contact pressure gauge.

Ball non-return valve

In order for the diaphragm leakage detection to work and to protect the diaphragms, the gap must be fully deaerated. Dosing heads with a double diaphragm are equipped with a ball non-return valve (T) to prevent air from flowing back during the filling and deaeration process (2u).

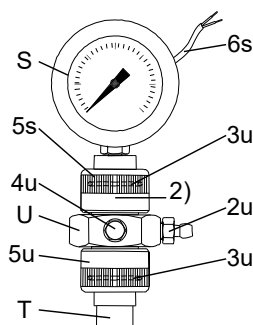

TMD036453

Contact pressure gauge

Pos.	Components
S	Contact pressure gauge
T	Ball non-return valve
U	Connection piece
2)	For dosing heads with a double diaphragm with no contact pressure gauge (no diaphragm leakage detection), a locking unit is fitted instead of the contact pressure gauge.

Functional principle of diaphragm leakage detection

The non-return valve and the gap between the diaphragms are factory-filled with a separating agent (paraffin oil). They are set in such a way during start-up on the test stand that there is always a hydraulically separated equilibrium between the valve and diaphragm gap (the pressure gauge indicates "0" when the pump is running and when it is stopped).

If one of these diaphragms breaks, the dosing or hydraulic medium penetrates into the gap between the diaphragms and, when the ball is removed, into the valve. The system pressure is therefore impinged on the valve and the contact pressure gauge is activated. Depending on the design of the system, the electrically isolated reed contact can trigger an alarm device or the pump can be switched off.

The contact is triggered at the preset pressure as is shown in the table below:

Description/use	Set pressure [bar]
For pumps up to 10 bar Pressure gauge 0 to 10 bar	1,5
For pumps up to 10 bar Explosion-proof pressure gauge 0 to 10 bar	1,5
For pumps 16 to 100 bar Pressure gauge 0 to 100 bar	10
For pumps 16 to 100 bar Explosion-proof pressure gauge 0 to 100 bar	10



Warning

The contact pressure gauge (Ex) in explosion-proof version with switch amplifier should be used if the pump is fitted with an explosion-proof motor.

5.2 Dimensions

5.2.1 Dimensions of DMH 251, 252, 253 and 254 single-head pumps

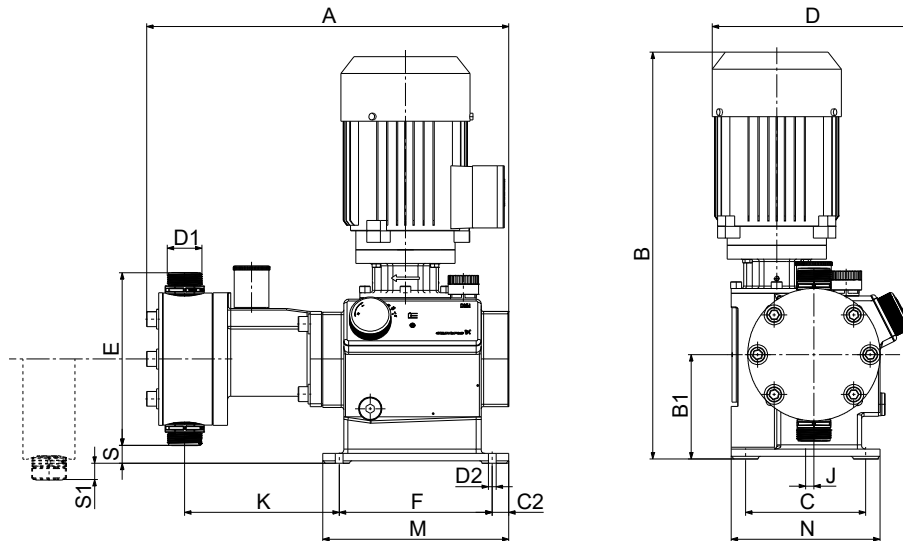

TM073711

All dimensions are in mm, except for the thread designations.

Pump model	A	B	C	C1	D	D1	D2	E	F	G	J	K	M	N	S	S1
DMH 251	345	336	97,5	14	192	G 5/8	9	160	152	85,5	16	116	180	117,5	5,9	-
DMH 252	345	336	97,5	14	192	G 5/8	9	160	152	85,5	16	116	180	117,5	5,9	-
DMH 253	368	335	97,5	14	192	G1 1/4	9	179	152	84	16	124	180	117,5	-	5,4
DMH 254	436	492	156	20	252	G1 1/4	9	207	185	126	10	187	225	180	22	-

5.2.2 Dimensions of DMH 251, 252, 253 and 254 double-head pumps

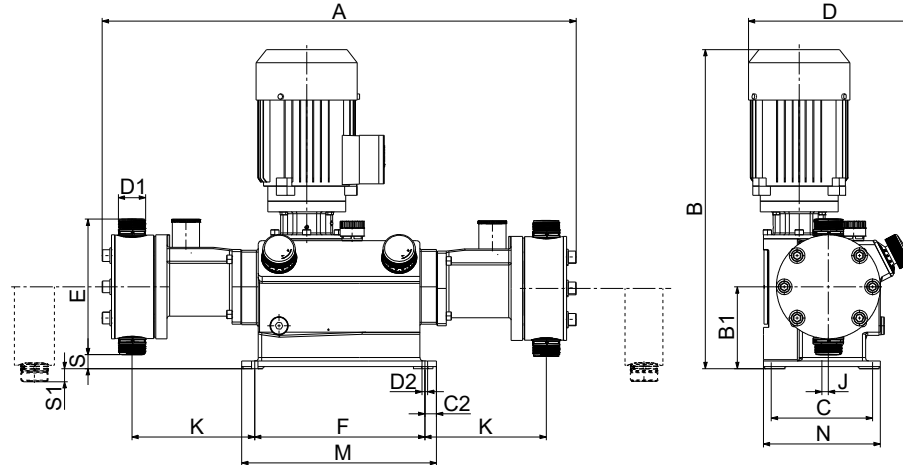

TM073718

All dimensions are in mm, except for the thread designations.

Pump model	A	B	C	C1	D	D1	D2	E	F	G	J	K	M	N	S	S1
DMH 251	432	336	97,5	14	192	G 5/8	9	160	152	85,5	16	116	180	117,5	5,9	-
DMH 252	432	336	97,5	14	192	G 5/8	9	160	152	85,5	16	116	180	117,5	5,9	-
DMH 253	472	335	97,5	14	192	G1 1/4	9	179	152	84	16	124	180	117,5	-	5,4
DMH 254	718	492	156	20	252	G1 1/4	9	207	260	126	10	187	300	180	22	-

5.2.3 Dimensions of DMH 255 single-head pumps with G 1 1/4 inlet connection

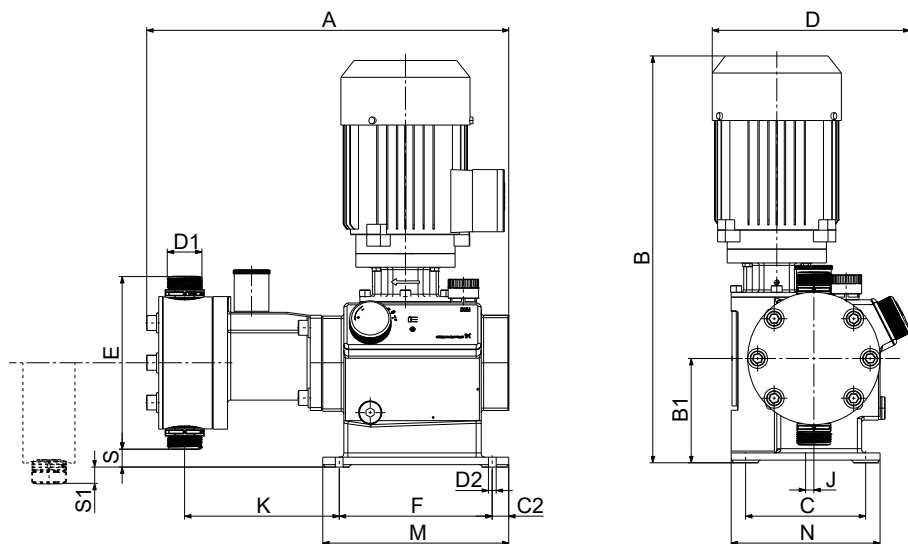

TM073711

All dimensions are in mm, except for the thread designations.

Pump model	A	B	C	C1	D	D1	D2	E	F	G	J	K	M	N	S	S1
DMH 255	510	492	156	20	254	G1 1/4	9	234	185	126	10	253	225	180	10,5	-

5.2.4 Dimensions of DMH 255 single-head pumps with flange on inlet side

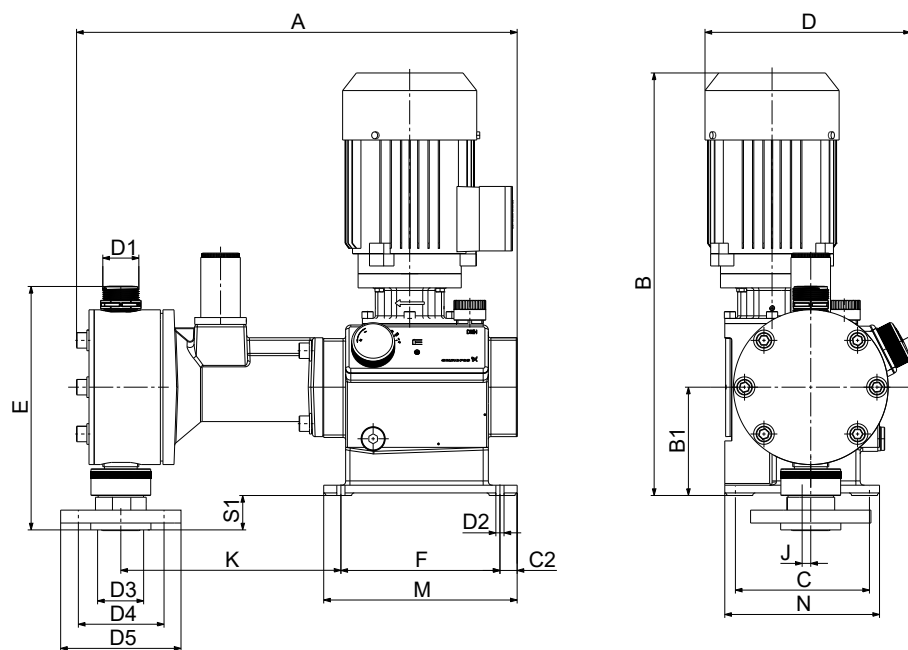

TM073712

All dimensions are in mm, except for the thread designations.

Pump model	Inlet flange D3	A	B	C	C1	D	D1	D2	D4	D5	E	F	G	J	K	M	N	S1
DMH 255	DN32	510	492	156	20	254	G1 1/4	9	100	140	283	185	126	10	253	225	180	41
DMH 255	ANSI 1 1/4	510	492	156	20	254	G1 1/4	9	88,9	117	283	185	126	10	253	225	180	41

5.2.5 Dimensions of DMH 255 double-head pumps with G 1 1/4 inlet connection

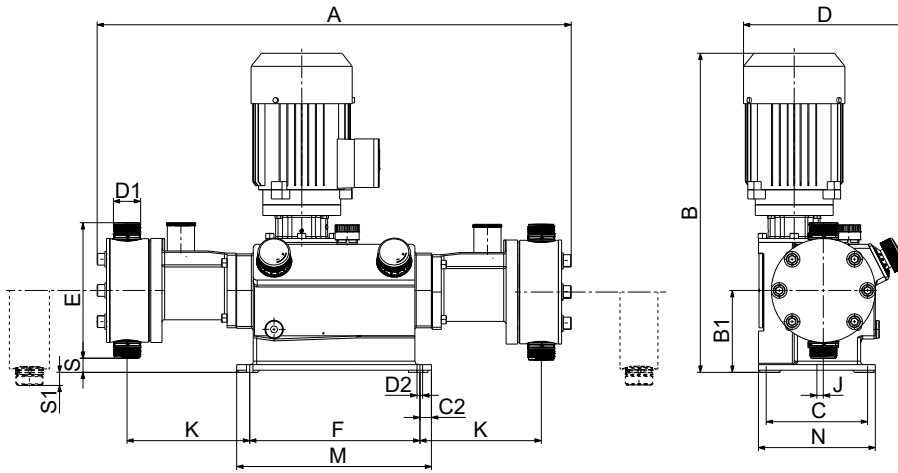

TM073718

All dimensions are in mm, except for the thread designations.

Pump model	A	B	C	C1	D	D1	D2	E	F	G	J	K	M	N	S	S1
DMH 255	869	492	156	20	254	G1 1/4	9	234	185	126	10	253	225	180	10,5	-

5.2.6 Dimensions of DMH 255 double-head pumps with flange on inlet side

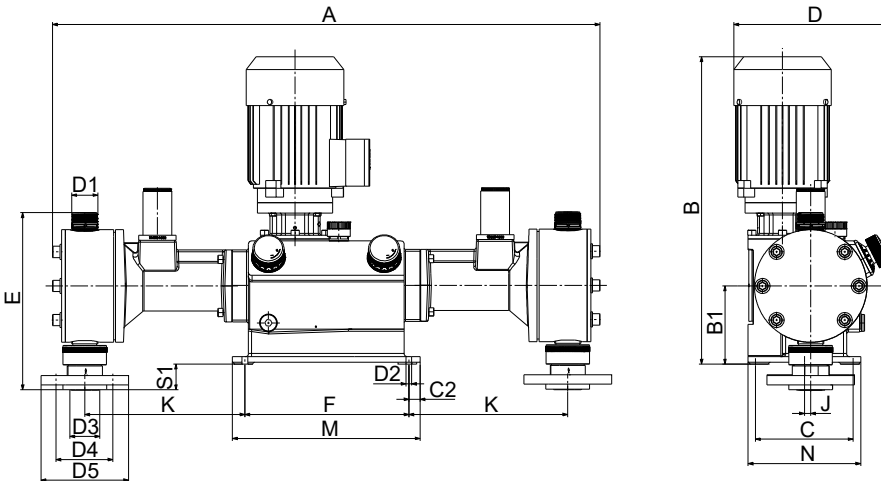

TM073719

All dimensions are in mm, except for the thread designations.

Pump model	Inlet flange D3	A	B	C	C1	D	D1	D2	D4	D5	E	F	G	J	K	M	N	S1
DMH 255	DN32	869	492	156	20	254	G1 1/4	9	100	140	283	260	126	10	253	300	180	41
DMH 255	ANSI 1 1/4	869	492	156	20	254	G1 1/4	9	88,9	117	283	260	126	10	253	300	180	41

5.2.7 Dimensions of DMH 257 single-head pumps

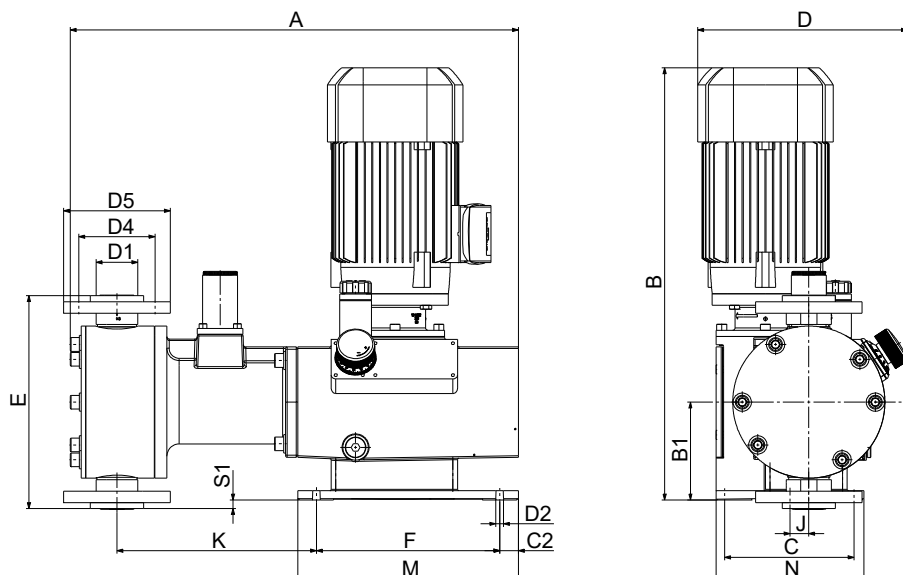

TM073713

All dimensions are in mm, except for the thread designations.

Pump model	Pump connection size D1	A	B	C	C1	D	D2	D4	D5	E	F	G	J	K	M	N	S1
DMH 257	DN32	589	572	170	24,5	278	9	100	140	280	241	128,5	25	262	290	194,5	12
DMH 257	ANSI 1 1/4	589	572	170	24,5	278	9	89	140	280	241	128,5	25	262	290	194,5	-

5.2.8 Dimensions of DMH 257 double-head pumps

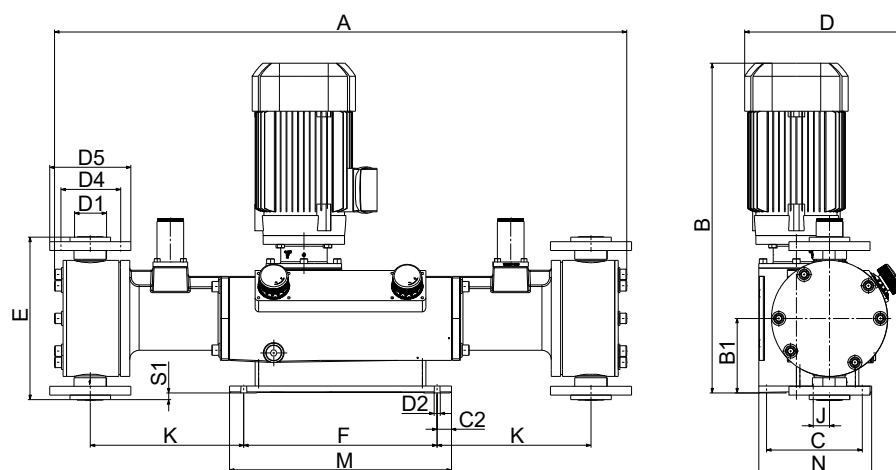

TM073720

All dimensions are in mm, except for the thread designations.

Pump model	Pump connection size D1	A	B	C	C1	D	D2	D4	D5	E	F	G	J	K	M	N	S1
DMH 257	DN32	980	572	170	24,5	278	9	100	140	280	333	128,5	25	262	382	194,5	12
DMH 257	ANSI 1 1/4	980	572	170	24,5	278	9	89	140	280	333	128,5	25	262	382	194,5	-

5.3 Weight

Pump model	Dosing head material	Weight [kg]	
		Single pump	Double pump
DMH 251	PVC, PP, PVDF	11	13
	Stainless steel 1.4571 Alloy C-4, 2.4610	13	17
DMH 252	PVC, PP, PVDF	11	13
	Stainless steel 1.4571 Alloy C-4, 2.4610	13	17
DMH 253	PVC, PP, PVDF	12	17
	Stainless steel 1.4571 Alloy C-4, 2.4610	14	21
DMH 254	PVC, PP, PVDF	27	32
	Stainless steel 1.4571 Alloy C-4, 2.4610	32	42
DMH 255	PVC, PP, PVDF	55	63
	Stainless steel 1.4571 Alloy C-4, 2.4610	65	83
DMH 257	PVC, PP, PVDF	56	88
	Stainless steel 1.4571 Alloy C-4, 2.4610	68	112

5.4 Stroke volume

Pump model	Stroke volume [cm ³]			
	4 bar	10 bar	16 bar	25 bar
DMH 251	-	3,5	3,1	2,9
DMH 252	-	6,4	6,3	-
DMH 253	-	11,3	-	-
DMH 254	-	31,6	30	-
DMH 255	-	60	-	-
DMH 257	171	131	-	-

5.5 Materials

Pump housing material

- Pump housing: Al 226.

AR control unit enclosure

- Upper part of enclosure: PPO blend
- Lower part of enclosure: aluminium.



Warning

Observe the chemical manufacturer's safety instructions when handling chemicals!

Make sure that the pump is suitable for the actual dosing medium!

The resistance of the parts that come into contact with the media depends on the media, media temperature and operating pressure. Ensure that parts in contact with the media are chemically resistant to the dosing medium under operating conditions!

Caution

Further information on resistance with regard to the media, media temperature and operating pressure is available on request.

Note

5.6 Data of contact pressure gauge for diaphragm leakage detection (optional)

Following data is not valid for contact pressure gauges in explosion-proof version.

The contact pressure gauge has a reed switch with electrically isolated contact output, maximum switching power 10 W for DC current or 10 VA for AC current. The maximum switching voltage is 75 V for DC current or 50 V for AC current, maximum switching current 0.5 A.

The switching function is set up as an NC contact, i.e. if the diaphragm breaks, the current circuit is interrupted.

The pressure gauge has a 2-metre cable.

Note

6. Installation

6.1 General information on installation



Warning

Observe the specifications for the installation location and range of applications described in section Technical data.



Warning

Faults, incorrect operation or faults on the pump or system can, for example, lead to excessive or insufficient dosing, or the permissible pressure may be exceeded. Consequential faults or damage must be evaluated by the operator and appropriate precautions must be taken to avoid them!



Warning

Risk of hot surfaces!

Pumps with AC motors may become hot.

Allow a minimum space of 100 mm to the fan cover!

A positive pressure difference of at least 2 bar is required between the suction valve and the discharge valve in order for the dosing pump to operate correctly.

Note

If the total counter-pressure (at the dosing point) and geodetic height difference between the suction valve and the dosing point is less than 2 bar (20 m WC), a pressure-loading valve must be installed immediately before the dosing point.

Related information

[3.2 Pump models and pump types](#)

6.2 Installation location

6.2.1 Space required for operation and maintenance

Note

The pump must be installed in a position where it is easily accessible during operation and maintenance work.

Maintenance work on the dosing head and the valves must be carried out regularly.

- Provide sufficient space for removing the dosing head and the valves.

6.2.2 Permissible ambient influences

See section Ambient and operating conditions.

Note

The installation site must be under cover!
Do not install outdoors!

Related information

[3.8 Ambient and operating conditions](#)

6.2.3 Mounting surface

The pump must be mounted on a flat surface.

6.3 Mounting

- Mount the pump on a console or pump foundation using four screws.

Note

The flow must run in the opposite direction to gravity!

6.4 Approximate values when using pulsation dampers

Risk of damage to the system!

It is always recommended to use pulsation dampers for large high-speed pumps!

In particular for pump types with a flow rate above 1000 l/h (DMH 257), suction and discharge pulsation dampers should be used directly at the pump suction and discharge ports of the pump. The size of the suction and discharge lines should be adjusted accordingly.

Since the pulsation is influenced by many factors, a system-specific calculation is essential. Request a calculation from our calculation program.

The table below indicates the approximate values and the suction line length for which suction pulsation dampers are required. The values apply to 50 Hz operation when water or similar liquids are dosed.

Pump model / pump type	Nominal width of suction line	Maximum length of suction line [m]
DMH 251		
DMH 2,2-25	DN 8	8
DMH 2,3-16	DN 8	8
DMH 2,4-10	DN 8	8
DMH 4,5-25	DN 8	8
DMH 4,9-16	DN 8	8
DMH 5-10	DN 8	8
DMH 11-25	DN 8	3
DMH 12-16	DN 8	3
DMH 13-10	DN 8	3
DMH 17-25	DN 8	1,5
DMH 18-16	DN 8	1,5
DMH 19-10	DN 8	1,5
DMH 21-25	DN 8	1
DMH 23-16	DN 8	1
DMH 24-10	DN 8	1
DMH 252		
DMH 10-16	DN 8	8
DMH 11-10	DN 8	8
DMH 23-16	DN 8	2
DMH 24-10	DN 8	2
DMH 36-16	DN 8	1
DMH 37-10	DN 8	1
DMH 45-16	DN 8	1
DMH 46-10	DN 8	1
DMH 54-16	DN 8	1
DMH 253		
DMH 21-10	DN 20	8
DMH 43-10	DN 20	8
DMH 67-10	DN 20	6
DMH 83-10	DN 20	4
DMH 100-10	DN 20	3
DMH 254		
DMH 50-10	DN 20	8
DMH 97-16	DN 20	8
DMH 102-10	DN 20	8
DMH 136-16	DN 20	5
DMH 143-10	DN 20	5
DMH 166-16	DN 20	3

Pump model / pump type	Nominal width of suction line	Maximum length of suction line [m]
DMH 175-10	DN 20	3
DMH 202-16	DN 20	1,5
DMH 213-10	DN 20	1,5
DMH 276-16	DN 20	1
DMH 291-10	DN 20	1
DMH 255		
DMH 194-10	DN 20	5
DMH 270-10	DN 20	3
DMH 332-10	DN 20	1,5
DMH 403-10	DN 20	1
DMH 550-10	DN 20	1,5
DMH 257		
DMH 272-16	DN 32	4,5
DMH 340-16	DN 32	3
DMH 440-10	DN 32	4,5
DMH 450-16	DN 32	1,5
DMH 520-16	DN 32	1
DMH 575-10	DN 32	3
DMH 680-16	DN 32	0,5
DMH 750-4	DN 32	1,5
DMH 770-10	DN 32	1,5
DMH 880-10	DN 32	1
DMH 1150-10	DN 32	0,5
DMH 1500-4	DN 32	0,5

6.5 Optimum installation

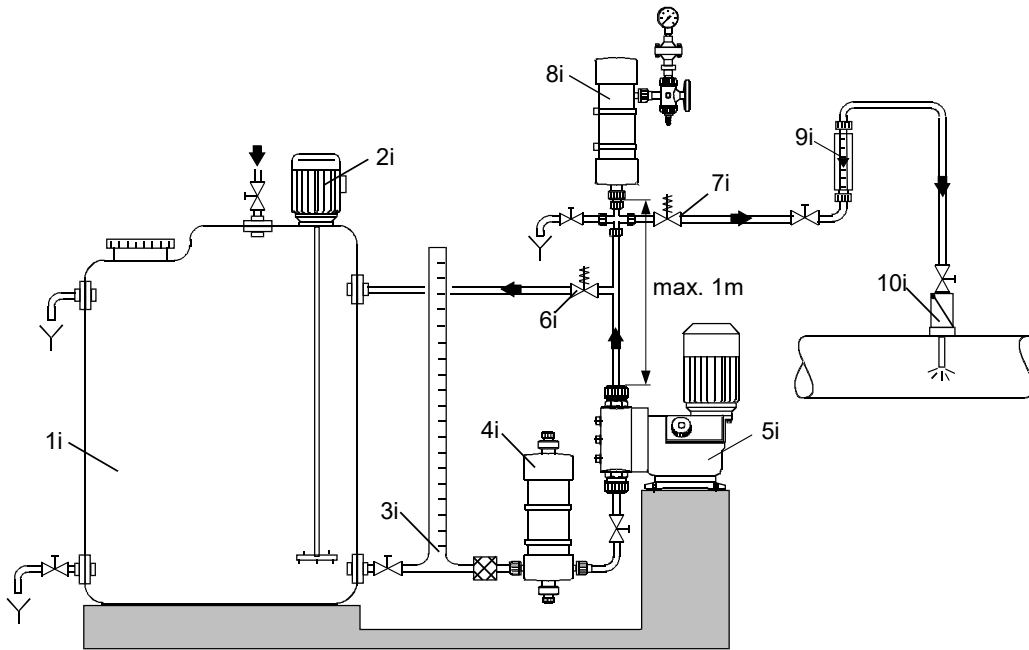

Example of optimum installation

Pos.	Components
1i	Dosing tank
2i	Electric agitator
3i	Extraction device
4i	Suction pulsation damper
5i	Dosing pump
6i	Relief valve
7i	Pressure-loading valve
8i	Pulsation damper
9i	Measuring glass
10i	Injection unit

TM036296

6.6 Installation tips

- For easy deaeration of the dosing head, install a ball valve (11i) with bypass line (back to the dosing tank) immediately after the discharge valve.
- In the case of long discharge lines, install a non-return valve (12i) in the discharge line.

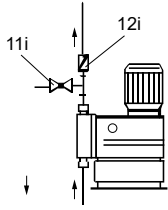

Installation with ball valve and non-return valve

- When installing the suction line, observe the following:
 - Keep the suction line as short as possible. Prevent it from becoming tangled.
 - If necessary, use swept bends instead of elbows.
 - Always route the suction line up towards the suction valve.
 - Avoid loops which may cause air bubbles.

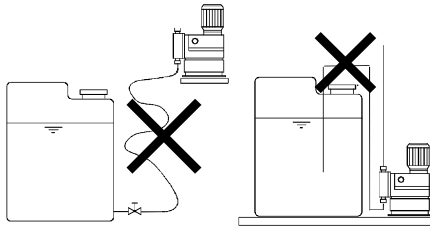

Installation of suction line

- For non-degassing media with a viscosity similar to water, the pump can be mounted on the tank (observe the maximum suction lift).
- Flooded suction preferred.
- For media with a tendency to sedimentation, install the suction line with filter (13i) so that the suction valve remains a few millimetres above the possible level of sedimentation.

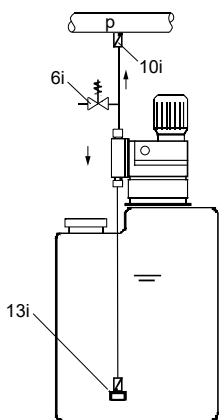

Tank installation

- Note for suction-side installation: Depending on the dosing flow and the line length, it may be necessary to install a properly sized pulsation damper (4i) immediately before the pump suction valve.

Note Observe section Approximate values when using pulsation dampers and, if necessary, request a system-specific calculation from our calculation program.

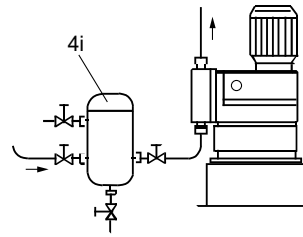

Installation with suction-side pulsation damper

- Note for discharge-side installation: Depending on the dosing flow and the line length, it may be necessary to install a properly sized pulsation damper (4i) on the discharge side.

Note To protect the system, use pulsation dampers (8i) for rigid piping longer than 2 metres and tubing longer than 3 metres, depending on pump type and size.

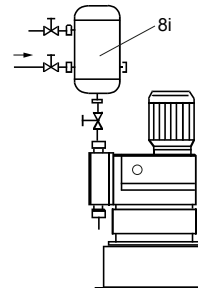

Installation with discharge-side pulsation damper

Risk of damage to the system!
It is always recommended to use pulsation dampers for large high-speed pumps!
Caution Since the pulsation is influenced by many factors, a system-specific calculation is essential. Request a calculation from our calculation program.

- For degassing and viscous media: flooded suction.
- Install a filter in the suction line to prevent the valves from becoming choked.
- To protect the dosing pump and the discharge line against excessive pressure build-up, install a relief valve (6i) in the discharge line.

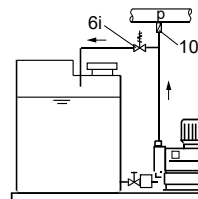

Installation with relief valve

With open outflow of the dosing medium or a counter-pressure below 2 bar

- Install a pressure-loading valve (7i) immediately before the outlet or the injection unit.

A positive pressure difference of at least 2 bar must be ensured between the counter-pressure at the injection point and the pressure of the dosing medium at the pump suction valve.

- If this cannot be ensured, install a pressure-loading valve (7i) in the discharge line.

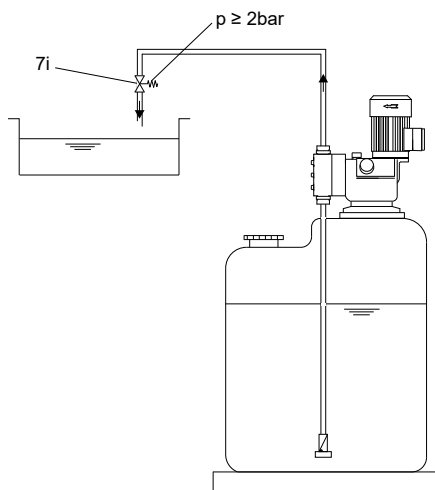

TM077841

Installation with pressure-loading valve

- To avoid the siphon effect, install a pressure-loading valve (7i) in the discharge line and, if necessary, a solenoid valve (14i) in the suction line.

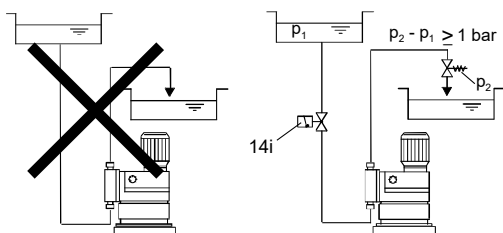

TM036304

Installation to avoid the siphon effect

Related information

6.4 Approximate values when using pulsation dampers

6.7 Tube / pipe lines

6.7.1 General

Warning

To protect the dosing system against excessive pressure build-up, install a relief valve in the discharge line.

Only use the prescribed line types!

All lines must be free from strain!

Avoid loops and buckles in the tubes!



Keep the suction line as short as possible to avoid cavitation!

If necessary, use swept bends instead of elbows.

Observe the chemical manufacturer's safety instructions when handling chemicals!

Make sure that the pump is suitable for the actual dosing medium!

The flow must run in the opposite direction to gravity!

The resistance of the parts that come into contact with the media depends on the media, media temperature and operating pressure. Ensure that parts in contact with the media are chemically resistant to the dosing medium under operating conditions!

Caution

6.8 Connecting the suction and discharge lines



Warning

All lines must be free from strain!

Only use the prescribed line types!

- Connect the suction line to the suction valve.
 - Install the suction line in the tank so that the foot valve remains 5 to 10 mm above the bottom of the tank or the possible level of sedimentation.
- Connect the discharge line to the discharge valve.

Connection of hose lines

- Push the hose firmly on the connection nipple and, depending on the connection, secure using a connection counterpart or hose clip.
- Fit the gasket.
- Screw the hose on the valve using the union nut.

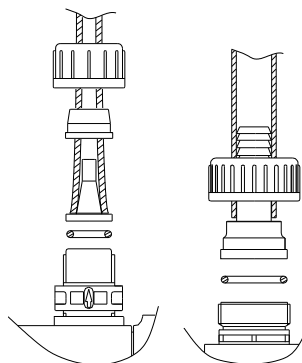

Connection of hose lines

TM036456

Connection of DN 20 pipe lines

- Depending on the pipe material and connection, glue the pipe (PVC), weld it (PP, PVDF or stainless steel) or press it in (stainless steel).
- Fit the gasket.
- Screw the pipe on the valve using the union nut.

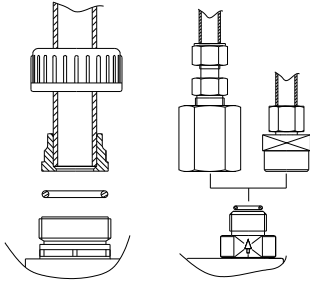

Connection of DN 20 pipe lines

TM036457

Connection of DN 32 pipe lines

- Depending on the pipe material, fit the pipe to the welding neck flange and weld it (stainless steel) or insert it into the headed bush and weld it (PP, PVDF).

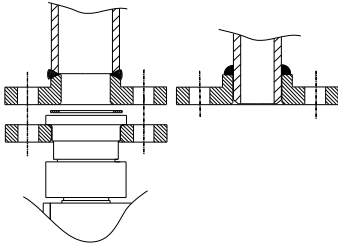

Connection of DN 32 pipe lines

TM036458

6.8.1 Connecting a liquid-heated dosing head (optional)

As an option, liquid-heated dosing heads are available in stainless steel.

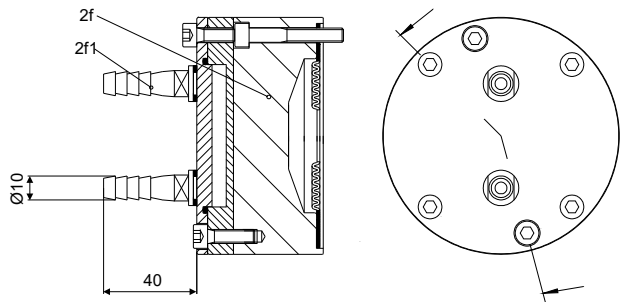

Liquid-heated dosing head

TM036459

Pos.	Components
2f	Dosing head, liquid-heated
2f1	Hose nipple, DN 10 connection

Required characteristics of heating liquid:

- The heating liquid must not chemically attack stainless steel.
- Maximum permissible pressure: $p_{max.} = 3 \text{ bar}$.
- Maximum permissible temperature: $t_{max.} = 100 \text{ }^\circ\text{C}$.

7. Electrical connections

Make sure that the pump is suitable for the electricity supply on which it will be used.

Warning

Electrical connections must only be carried out by qualified personnel!

Disconnect the power supply before connecting the power supply cable and the relay contacts!

Observe the local safety regulations!



The pump housing must only be opened by personnel authorised by Grundfos!

Protect the cable connections and plugs against corrosion and humidity.

Only remove the protective caps from the sockets that are being used.

7.1 Electric servomotor (optional)

To connect the servomotor to the power supply, see the installation and operating instructions for the servomotor.

7.2 Electronic preselection counter (optional)

To connect the preselection counter to the power supply, see the installation and operating instructions for the counter.

7.3 Electrically heated dosing head (optional)

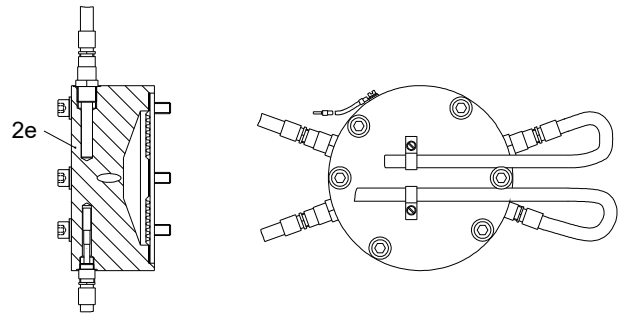

Electrically heated dosing head

TM036460

Pos.	Component
2e	Dosing head, electrically heated

- To connect the temperature controller to the power supply, see the installation and operating instructions for the electric temperature controller.

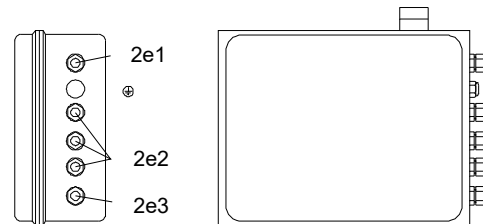

Temperature controller

TM036461

Pos.	Connections
2e1	Sensor
2e2	Heating
2e3	Power supply

7.4 Diaphragm controller (optional)

Warning



Explosion-proof pumps with diaphragm leakage detection are fitted with a contact pressure gauge in explosion-proof version.

The pressure gauge must be earthed.

Connecting the earth cable (4u), see figure below.

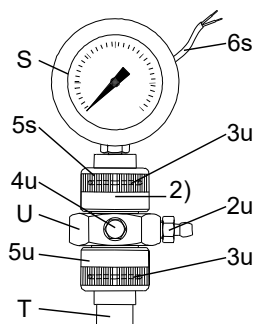

TMO36453

Diaphragm controller

Pos.	Components
S	Contact pressure gauge
5s	Union nut
6s	Contact output
T	Ball non-return valve
U	Connection piece
2u	Deaeration screw
3u	O-rings
4u	Connection for earth cable
5u	Union nut
2)	or locking unit (instead of contact pressure gauge and its connection)

7.5 Connecting the power supply cable

Warning

Disconnect the power supply before connecting the power supply cable!



Before connecting the power supply cable, check that the rated voltage stated on the pump nameplate corresponds to the local conditions!

Do not make any changes to the power supply cable or plug!

The assignment between the plug-and-socket connection and the pump must be labelled clearly (e.g. by labelling the socket outlet).

Caution

The pump can be automatically started by connecting the power supply!

Caution

- Do not switch on the power supply until you are ready to start the pump.

7.5.1 Versions with mains plug

- Insert the mains plug in the mains socket.

7.5.2 Versions without mains plug

Warning



The pump must be connected to an external clearly labelled mains switch with a minimum contact gap of 3 mm in all poles.

- Connect the motor to the power supply in accordance with local electrical installation regulations and the connection chart on the terminal box cover.

Warning



The specified enclosure class can only be ensured if the power supply cable is connected with the same degree of protection.

Observe the direction of rotation!

Caution

To protect the motor, install a motor protecting switch or motor contactor, and set the bimetal relay to the rated motor current for the available voltage and frequency.

8. Start-up/shutdown

8.1 Initial start-up/subsequent start-up

Warning

When dosing dangerous media, observe the corresponding safety precautions!

Wear protective clothing (gloves and goggles) when working on the dosing head, connections or lines!



Before removing the dosing head, valves and lines, empty any remaining medium in the dosing head into a drip tray by carefully unscrewing the suction valve.

The pump housing must only be opened by personnel authorised by Grundfos!

Repairs must only be carried out by authorised and qualified personnel!



Observe the flow direction of valves (indicated by an arrow on the valve)!

Only tighten plastic valves by hand.

8.1.1 Checks before start-up

- Check that the rated voltage stated on the pump nameplate corresponds to the local conditions!
- Check that all connections are secure and tighten, if necessary.
- Check that the dosing head screws are tightened with the specified torque and tighten, if necessary.
- Check that all electrical connections are correct.
- Cross-tighten the dosing head screws using a torque wrench.

Torques

Pump model	Torque [Nm]
DMH 251, 10 bar	8-10
DMH 251, 16 bar	10-12
DMH 251, 25 bar	13-15
DMH 252	8-10
DMH 253	10-12
DMH 254	50-54
DMH 255	50-54
DMH 257	50-54

8.1.2 Oil filling

The pump is factory-checked, and the oil is drained for shipping purposes. Before start-up, add the special oil supplied with the pump.



The piston flange is filled with oil for easy start-up. The stroke-length adjustment knob must only be adjusted if the gear oil has been added, otherwise the oil will leak from the piston flange.

1. Slacken and remove the oil-filling screw (F).
2. Slowly add the hydraulic oil supplied with the pump through the oil-filling opening (F) until the oil reaches the mark on the oil dipstick.
3. Set the stroke-length adjustment knob (L) to "0".

8.1.3 Filling the dosing head for the initial start-up for systems without flooded suction

Warning



When dosing dangerous media, observe the corresponding safety precautions!

Wear protective clothing (gloves and goggles) when working on the dosing head, connections or lines!

As assisting suction for systems without flooded suction, you can fill the dosing head with dosing medium before the initial start-up:

1. Unscrew the discharge valve (3b).
2. Add the dosing medium to the dosing head (2).
3. Screw the discharge valve (3b) back in.



Observe the flow direction of the discharge valve (indicated by an arrow on the valve)!

8.2 Start-up/subsequent start-up of DMH 251, 252 and 253

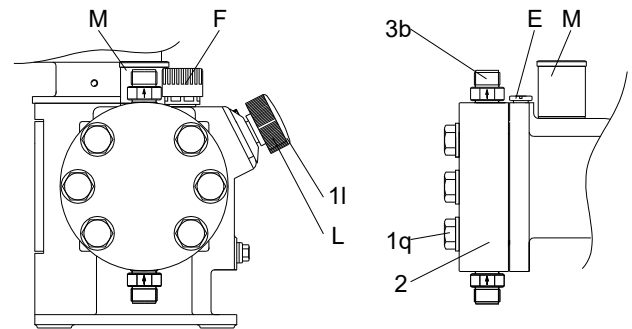

Start-up of DMH 251, 252 and 253

Pos.	Components
1q	Dosing head screws
2	Dosing head
3b	Discharge valve
E	Degassing valve
F	Oil-filling screw with dipstick
L	Stroke-length adjustment knob
1l	Cover for stroke-length adjustment knob
M	Pressure relief valve

1. Connect the electrical power supply.
2. Depending on the installation, start the pump, where possible, without counter-pressure.
See installation example for easy deaeration of the dosing head in section Installation.
3. Set the stroke-length adjustment knob (L) to 0 %.
4. Let the pump run for approx. 5 minutes.
5. Check the oil level.
 - Set the stroke-length adjustment knob (L) to 40 %.
 - Let the pump run for approx. 10 minutes with a stroke-length setting of 40 %.
 - Switch off the pump, check the oil level and add oil, if necessary.
 - Refit the oil-filling screw (F).
6. Deaerate the piston flange.
 - Set the stroke-length adjustment knob (L) to 15 %.
 - Loosen the degassing valve (E) by one turn to the left.
 - Let the pump run for approx. 5 minutes.
 - Re-tighten the degassing valve (E).

The pump is now ready for operation.

Warning

Risk of injury caused by squirting oil!



Oil may squirt from the oil deaeration when the pump is running. Do not completely unscrew the oil deaeration screw.

Wear protective clothing (gloves and goggles) when working on the dosing head, connections or lines!

Note

Rod length of oil dipstick: 27 mm.
Immersion depth to marking: approx. 5 mm.

Check the oil level at least every two weeks and add oil, if necessary.

Note

Only use original Grundfos gear oil!
For product numbers, see "Service kit catalogue" on www.grundfos.com

Pump model	Version	Description
DMH 251	Single/double	1,3 l white oil (Paraffin 55 DAB7)
DMH 252, 10 bar	Single/double	1,3 l white oil (Paraffin 55 DAB7)
DMH 252, 16 bar	Single/double	1,3 l DHG 68
DMH 253	Single/double	1,3 l DHG 68

After start-up

After initial start-up and after each time the diaphragm is changed, tighten the dosing head screws.

Caution

After approximately 6-10 operating hours or two days, cross-tighten the dosing head screws using a torque wrench.

Torques

Pump model	Torque [Nm]
DMH 251, 10 bar	8-10
DMH 251, 16 bar	10-12
DMH 251, 25 bar	13-15
DMH 252	8-10
DMH 253	10-12

Related information

[6.1 General information on installation](#)

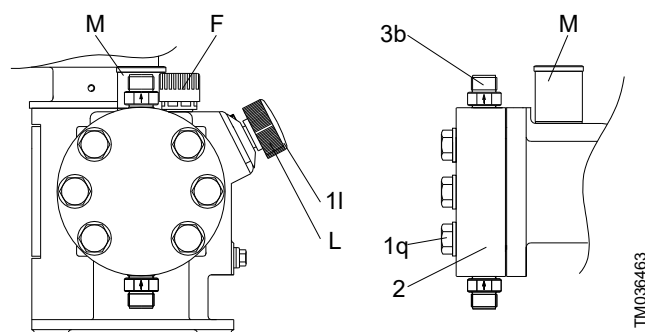
8.3 Start-up/subsequent start-up of DMH 254, 255 and 257

Start-up of DMH 254, 255 and 257

Pos.	Components
1q	Dosing head screws
2	Dosing head
3b	Discharge valve
F	Oil-filling screw with dipstick
L	Stroke-length adjustment knob
1l	Cover for stroke-length adjustment knob
M	Pressure relief valve

1. Connect the electrical power supply.
2. Depending on the installation, start the pump, where possible, without counter-pressure.
See installation example for easy deaeration of the dosing head in section Installation.
3. Set the stroke-length adjustment knob (L) to 0 %.
4. Let the pump run for approx. 5 minutes.
5. Check the oil level.
 - Set the stroke-length adjustment knob (L) to 40 %.
 - Let the pump run for approx. 10 minutes with a stroke-length setting of 40 %.
 - Switch off the pump, check the oil level and add oil, if necessary.
 - Refit the oil-filling screw (F).

The pump is now ready for operation.

Warning

Risk of injury caused by squirting oil!



Oil may squirt from the oil deaeration when the pump is running. Do not completely unscrew the oil deaeration screw.

Wear protective clothing (gloves and goggles) when working on the dosing head, connections or lines!

Note

Rod length of oil dipstick: 35 mm.
Immersion depth to marking: approx. 5 mm.

Check the oil level at least every two weeks and add oil, if necessary.

Note

Only use original Grundfos gear oil!
For product numbers, see "Service kit catalogue" on www.grundfos.com

Pump model	Version	Description
DMH 254	Single	3,5 l DHG 68
DMH 254	Double	4,5 l DHG 68
DMH 255	Single	3,5 l DHG 68
DMH 255	Double	4,5 l DHG 68
DMH 257	Single	5,5 l DHG 68
DMH 257	Double	7,5 l DHG 68

After start-up

After initial start-up and after each time the diaphragm is changed, tighten the dosing head screws.

Caution After approximately 6-10 operating hours or two days, cross-tighten the dosing head screws using a torque wrench.

Torques

Pump model	Torque [Nm]
DMH 254	50-54
DMH 255	50-54
DMH 257	50-54

Related information

6.1 General information on installation

8.4 Setting the pressure relief valve

The pressure relief valve is set to the pressure given by the customer, or to the rated pressure (maximum counter-pressure). The opening pressure can be set to a lower value by the customer.

Opening pressure of the pressure relief valve

Rated pressure of the pump [bar]	Opening pressure of the pressure relief valve [bar]
4	5
10	13
16	18
25	28

Setting the opening pressure

- To set the operating pressure, a pressure gauge must be installed in the discharge line and an isolating valve must be installed after the pressure gauge.
- To set the pressure relief valve, use a screwdriver.

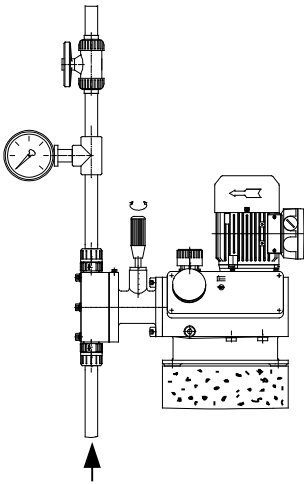

Setting the opening pressure

Set the pressure relief valve as follows:

- Close the isolating valve after the pressure gauge.
- Remove the cover (1 m) from the pressure relief valve.
- Start the pump.
- Using a screwdriver, slowly turn the adjusting screw (2 m) of the pressure relief valve counter-clockwise until the desired opening pressure is obtained.

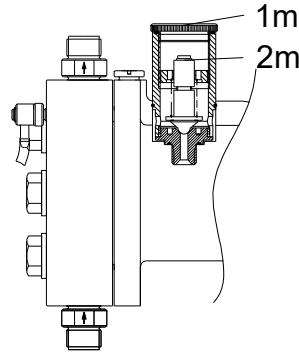

Setting the pressure relief valve

Risk of damage to the pump or system!

Caution

When blocked, the pressure relief valve does not work properly and can produce pressures of several hundred bar in the pump or system.

Do not block the pressure relief valve during adjustments!

- Replace the cover of the pressure relief valve.
- Open the isolating valve after the pressure gauge.

8.5 Zero point adjustments

8.5.1 Adjusting the zero point for system pressures up to 100 bar

The zero point of the dosing pump is factory-set to a slightly lower counter-pressure than the rated pressure of the pump. If the operating counter-pressure deviates considerably from this value, an adjustment of the zero point will ensure more precise values.

Counter-pressure at the factory-set zero point of the pump

Rated pressure of the pump [bar]	Counter-pressure at the factory-set zero point [bar]
10	3
16	3
25	10

8.5.2 Adjusting the zero point

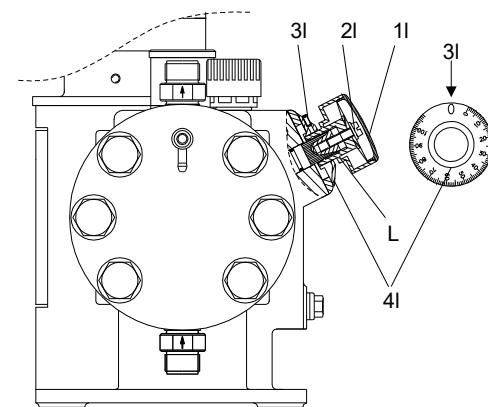

Adjusting the zero point

Pos.	Components
L	Stroke-length adjustment knob
1l	Cover
2l	Locking screw
3l	Screw
4l	Scale ring

TM036465

TM036464

TM036466

Warning

When dosing dangerous media, observe the corresponding safety precautions!

Wear protective clothing (gloves and goggles) when working on the dosing head, connections or lines!

Always adjust the value with the discharge line connected and with operating counter-pressure.

1. Fit a measuring device on the suction side, for instance place the suction line in a graduated measuring beaker.
2. Set the dosing flow to 15 %.
3. Remove the cover (11) from the stroke-length adjustment knob (L).
4. Use a screwdriver to loosen the locking screw (21) by approximately 2 turns.
5. Switch on the pump.
6. Slowly turn the stroke-length adjustment knob towards the zero point until the dosing (the liquid level falls) stops in the measuring device.
7. Switch off the pump.
8. Set the scale ring (41) to zero.
 - Loosen the screw (31) in the scale ring (41) slightly using an hexagon key, M3.
 - Turn the scale ring (41) until both "0" are the same on the scale and scale ring.
 - Tighten the screw (31).
9. Depending on the application, tighten the locking screw (21) so that the stroke-length adjustment knob can still be turned/cannot be turned any more.
10. Replace the cover (11).

8.6 Operating the pump**Note**

When operating the pump, see sections Operation and Maintenance, if necessary, section Fault finding chart.

Related information

[9.1 Switching on/off](#)

[10.1 General notes](#)

[11. Fault finding chart](#)

8.7 Shutdown**Warning**

Wear protective clothing (gloves and goggles) when working on the dosing head, connections or lines!

Do not allow any chemicals to leak from the pump. Collect and dispose of all chemicals correctly!

Note

If possible, rinse the dosing head before shutting down the pump, e.g. by supplying it with water.

8.7.1 Switching off/uninstalling

1. Switch off the pump and disconnect it from the power supply.
2. Depressurise the system.
3. Take suitable steps to ensure that the returning dosing medium is safely collected.
4. Carefully remove all lines.
5. Uninstall the pump.

8.7.2 Cleaning

1. Rinse all parts that have come into contact with the medium very carefully:
 - lines
 - valves
 - dosing head
 - diaphragm.
2. Remove any trace of chemicals from the pump housing.

8.7.3 Storage

Storage of the pump:

1. After cleaning, carefully dry all parts and reinstall the dosing head and valves, or
2. change the valves and diaphragm.

See section Maintenance.

Related information

[8.7.2 Cleaning](#)

[10.1 General notes](#)

8.7.4 Disposal

Disposal of the pump:

- After cleaning, dispose of the pump in accordance with the relevant regulations.

Related information

[8.7.2 Cleaning](#)

[13. Disposing of the product](#)

9. Operation

9.1 Switching on/off

Caution Before switching on the pump, check that it is installed correctly. See sections Installation and Start-up/shut-down.

- To start the pump, switch on the power supply.
- To stop the pump, switch off the power supply.

Related information

[6.1 General information on installation](#)

[8.1 Initial start-up/subsequent start-up](#)

9.2 Setting the dosing capacity

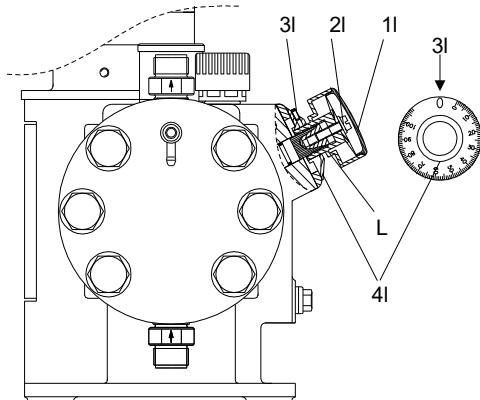

Setting the dosing capacity

Pos.	Components
L	Stroke-length adjustment knob
1l	Cover
2l	Locking screw
3l	Screw
4l	Scale ring

9.2.1 Setting the dosing flow and locking the stroke-length adjustment knob

1. Remove the cover (1l) from the stroke-length adjustment knob (L).
2. Use a screwdriver to loosen the locking screw (2l) by approximately 2 turns.
3. Increase or *reduce* the dosing flow while the pump is running.
 - Slowly turn the stroke-length adjustment knob to the left or right to set the desired dosing volume.
4. Depending on the application, tighten the locking screw (2l) so that the stroke-length adjustment knob can still be turned/cannot be turned any more.
5. Replace the cover (1l).

The pump cannot be operated if the stroke-length adjustment knob is fully open! Depending on the pump adjustment, this value may already be lower than 100 % on the scale for system pressures higher than 100 bar.

Caution Open the stroke-length adjustment knob completely and then close by approx. 10 % in order to set the dosing flow to 100 %.

9.3 Using the AR control unit (optional)

When using the AR control unit, observe the installation and operating instructions for the "AR control unit" in addition to the instructions in this manual.

9.4 Electric servomotor (optional)

To operate the servomotor, see the installation and operating instructions for the servomotor.

9.5 Electronic preselection counter (optional)

To operate the preselection counter, see the installation and operating instructions for the counter.

9.6 Electrically heated dosing head (optional)

To operate the temperature controller, see the installation and operating instructions for the temperature controller.

10. Maintenance

10.1 General notes

Warning

When dosing dangerous media, observe the corresponding safety precautions!

Wear protective clothing (gloves and goggles) when working on the dosing head, connections or lines!



The pump housing must only be opened by personnel authorised by Grundfos!

Repairs must only be carried out by authorised and qualified personnel!

Switch off the pump and disconnect it from the power supply before carrying out maintenance work and repairs!

Before removing the dosing head, valves and lines, empty any remaining medium in the dosing head into a drip tray by carefully unscrewing the suction valve.

Caution

Observe the flow direction of valves (indicated by an arrow on the valve)!

Only tighten plastic valves by hand.

10.2 Diaphragm leakage control for diaphragm leakage detection

If a diaphragm leakage has been detected, first of all check whether an error has been displayed, as different external factors such as the heating of dosing or hydraulic medium can cause the cracked medium between the diaphragms to be displaced into the valve, thereby causing an error to occur.

Checks after a diaphragm leakage detection:

1. Briefly open the deaeration screw (2u) and then close it again.
2. Switch on the pump.
3. If, after a short period of time, a diaphragm leakage is detected again, a diaphragm has broken.

Caution

After a diaphragm breakage, replace the diaphragms and clean the non-return valve, see section Replacing the diaphragm for dosing head with double diaphragm.

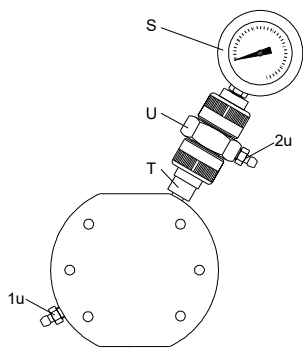

TM036467

Dosing head with double diaphragm

Pos.	Components
S	Contact pressure gauge
T	Ball non-return valve
U	Connection piece
1u	Filling screw
2u	Deaeration screw

Related information

[10.7 Replacing the diaphragm for dosing head with double diaphragm](#)

10.3 Cleaning and maintenance intervals

Checking the oil level

- Check the oil level every two weeks and add oil, if necessary.

Cleaning the valves

- At least every 12 months or after 4,000 operating hours.
- If the pump does not perform.
- In the event of a fault.

Clean the valves and replace, if necessary (for stainless-steel valves: inner valve parts).

Changing diaphragms and gear oil

- At least every 12 months or after 8,000 operating hours, change the dosing diaphragm and gear oil.
- In dusty installation sites, change the gear oil every 3,000 operating hours.

Cleaning the ball non-return valve of the double diaphragm

- After a diaphragm breakage, remove the ball non-return valve immediately and clean it.

Note

Only clean the ball non-return valve after a diaphragm breakage!

10.4 Checking the oil level

Caution

Check the oil level at least every two weeks and add oil, if necessary.

Rod length of oil dipstick:

Note

DMH 251-253: 27 mm.

DMH 254-257: 35 mm.

Immersion depth to marking: approx. 5 mm.

10.5 Cleaning the suction and discharge valves

Warning

Wear protective clothing (gloves and goggles) when working on the dosing head, connections or lines!



Before removing the dosing head, valves and lines, empty any remaining medium in the dosing head into a drip tray by carefully unscrewing the suction valve.

DN 8 valve

- Screwed connection 5/8"
- Stainless steel or plastic
- Spring-loaded (optional).

DN 20 valve (valve for suction side only), with adapter

- Screwed connection 1 1/4"
- Plastic.

DN 20 valve

- Screwed connection 1 1/4"
- Stainless steel or plastic
- Spring-loaded (optional).

DN 32 valve (for 60 Hz operation, suction side only), with adapter

- Flange connection
- Stainless steel or plastic.

Clean the suction and discharge valves as follows:

1. Unscrew the valves.
2. Unscrew the screw parts and valve set using round pliers.
3. Dismantle the inner part (seat, O-ring, balls, ball cages and, if present, spring).
4. Clean all parts. Replace faulty parts by new ones.
5. Re-assemble the valve.
6. Replace the O-rings by new ones. Refit the valve.

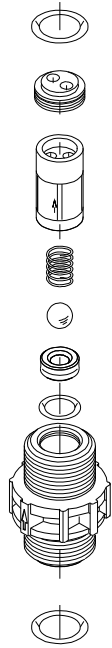

TM036468

Stainless-steel or plastic DN 8 valve, spring-loaded as an option

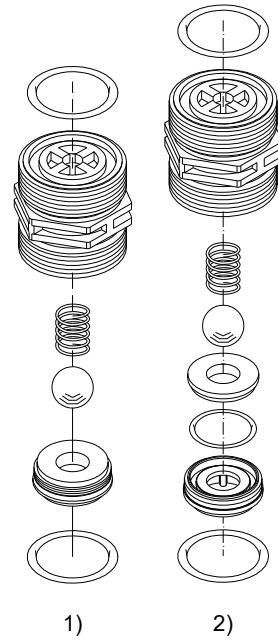

TM036470

Stainless-steel (1) or plastic (2) DN 20 valve, spring-loaded as an option

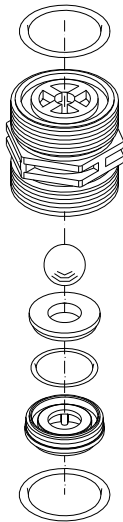

TM036469

Plastic DN 20 valve

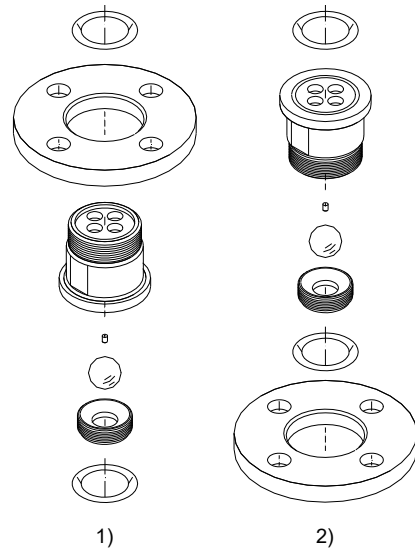

TM036471

DN 32 valve, suction side (1) and discharge side (2)

The O-rings must be correctly placed in the specified groove.

Caution Observe the flow direction (indicated by an arrow on the valve)!

Only tighten plastic valves by hand.

10.6 Replacing the diaphragm and gear oil for dosing head with single diaphragm (no diaphragm leakage detection)

Warning

Wear protective clothing (gloves and goggles) when working on the dosing head, connections or lines!



The dosing diaphragm should be replaced with each gear oil change.

Before removing the dosing head, valves and lines, empty any remaining medium in the dosing head into a drip tray by carefully unscrewing the suction valve.

Only use original Grundfos gear oil!

Note For product numbers, see "Service kit catalogue" on www.grundfos.com

Pump model	Version	Description
DMH 251	Single/double	1,3 l white oil (Paraffin 55 DAB7)
DMH 252, 10 bar	Single/double	1,3 l white oil (Paraffin 55 DAB7)
DMH 252, 16 bar	Single/double	1,3 l DHG 68
DMH 253	Single/double	1,3 l DHG 68
DMH 254	Single	3,5 l DHG 68
DMH 254	Double	4,5 l DHG 68
DMH 255	Single	3,5 l DHG 68
DMH 255	Double	4,5 l DHG 68
DMH 257	Single	5,5 l DHG 68
DMH 257	Double	7,5 l DHG 68

Note Collect the gear oil in a container and dispose of it correctly.

10.6.1 Drain gear oil

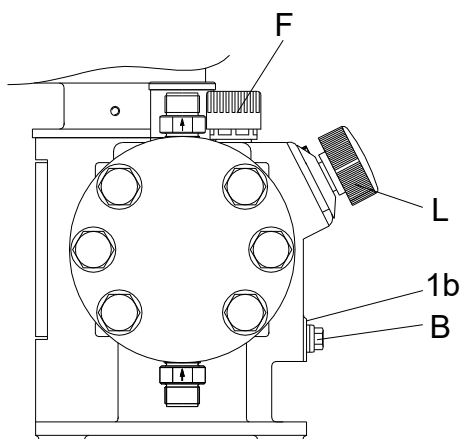

Drain gear oil

Pos.	Components
B	Locking screw
1b	Gasket
F	Oil-filling screw with dipstick
L	Stroke-length adjustment knob

- Unscrew the locking screw (B) and collect the gear oil in a container.
- Screw the locking screw (B) and the new gasket (1b) back in and tighten securely.

Caution Risk of leaking oil and damage caused by oil loss!
For each oil change, a new flat gasket (1b) must be fitted!

10.6.2 Removing the dosing head

- Close the suction and discharge lines and loosen the suction and discharge valve connections.
- Loosen the six dosing head screws (1q with 2q).
- Remove the dosing head (2).

10.6.3 Replacing a single diaphragm (no diaphragm leakage detection)

- Remove the diaphragm and fit a new diaphragm (Q) on the suction side.

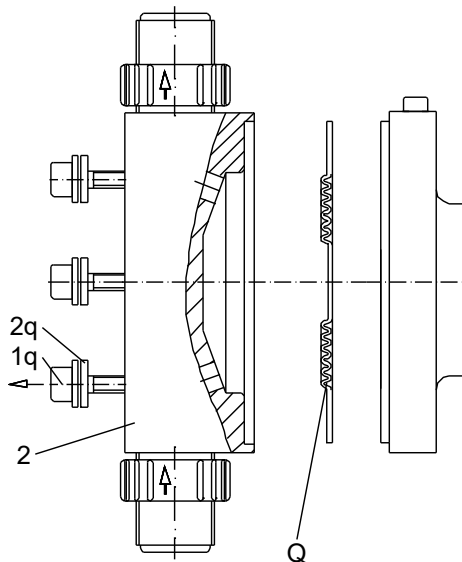

Replacing a single diaphragm

Pos.	Components
1q	Dosing head screw
2q	Intermediate disk
2	Dosing head
Q	Diaphragm

10.6.4 Fitting the dosing head

- Fit the dosing head and cross-tighten the dosing head screws (1q with 2q) using a torque wrench.

Note See section Start-up/shutdown for subsequent start-up!

Related information

[8.1 Initial start-up/subsequent start-up](#)

10.6.5 Filling with gear oil

Caution Risk of leaking oil and damage caused by oil loss!
For each oil change, a new flat gasket (1b) must be fitted!

- Check that the locking screw (B) is tightened.
- Slacken and remove the oil-filling screw (F).
- Set the stroke-length adjustment knob (L) to "0".
- Slowly add the hydraulic oil through the oil-filling opening (F) until the oil reaches the mark on the oil dipstick.
- Wait 30 minutes.
- Let the pump run for approx. 5 minutes with a stroke-length setting of 0 %.
- Let the pump run for approx. 10 minutes with a stroke-length setting of 40 %.

TM036473

TM036472

10.6.6 Checking the oil level

1. Switch off the pump, check the oil level and add oil, if necessary.
2. Refit the oil-filling screw (F).

After initial start-up and after each time the diaphragm is changed, tighten the dosing head screws.

Caution After approximately 6-10 operating hours or two days, cross-tighten the dosing head screws using a torque wrench.

Torques

Pump model	Torque [Nm]
DMH 251, 10 bar	8-10
DMH 251, 16 bar	10-12
DMH 251, 25 bar	13-15
DMH 252	8-10
DMH 253	10-12
DMH 254	50-54
DMH 255	50-54
DMH 257	50-54

10.7 Replacing the diaphragm for dosing head with double diaphragm

Warning

Wear protective clothing (gloves and goggles) when working on the dosing head, connections or lines!



The dosing diaphragm should be replaced with each gear oil change.

Before removing the dosing head, valves and lines, empty any remaining medium in the dosing head into a drip tray by carefully unscrewing the suction valve.

Only use original Grundfos gear oil!

Note For product numbers, see "Service kit catalogue" on www.grundfos.com

10.7.1 Removing the dosing head

1. Close the suction and discharge lines and loosen the suction and discharge valve connections.
2. Loosen the six dosing head screws (1q with 2q).
3. Remove the dosing head (2).

10.7.2 Replacing a double diaphragm

1. Clean the intermediate disk (3q), sealing rings (4q) and covering rings (5q). After a diaphragm breakage, replace the parts by new ones.
2. Remove both clamping sleeves (6q) slightly using pliers. After a diaphragm breakage, replace the parts by new ones.
3. Measure the outer wall thickness of both new diaphragms (Q1 and Q2): $s_{1(Q1)} < s_{2(Q2)}$.

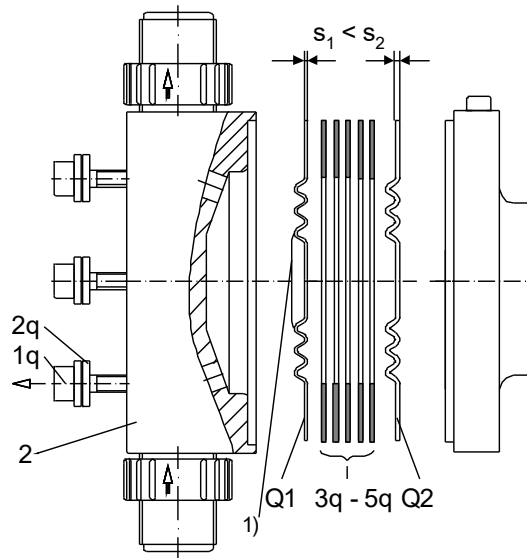

Installation of diaphragm

- 1) The shape of the diaphragm varies depending on pump type.

Pos.	Components
1q	Dosing head screw
2q	Intermediate disk
2	Dosing head
Q1/Q2	See fig. Diaphragm on dosing-head side
3q - 5q	

Caution Observe correct installation of diaphragms (Q1 and Q2)! See fig. Diaphragm on dosing-head side. Fit the thinner diaphragm (Q1) on the dosing side and the thicker diaphragm (Q2) on the oil side/pump side!

4. Fit both new diaphragms (Q1 and Q2) and the parts (3q - 5q) in the correct order, as is shown in the diagrams (the clamping sleeves (6q) are used for centring purposes).

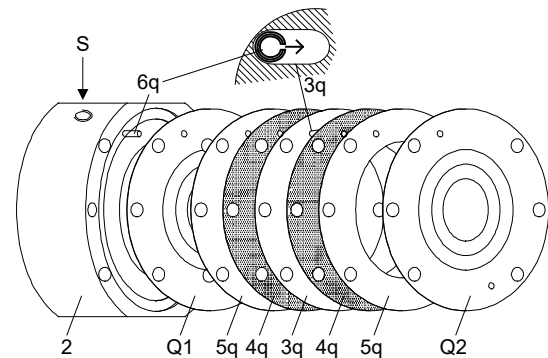

Diaphragm on dosing-head side

Pos.	Components
S	Contact pressure gauge (installation position)
Q1	Diaphragm on dosing-head side
Q2	Diaphragm on oil side/pump side
3q	Intermediate disk
4q	Sealing rings
5q	Covering rings
6q	Clamping sleeves

TM036474

TM036475

The paraffin oil between the diaphragms (Q) is connected via the clamping sleeves (6q) to the contact pressure gauge (S) in order to fill and activate the diaphragm leakage detection. The oil is able to pass between the diaphragms through the slits in the clamping sleeves and the slits in the intermediate disk.

Caution

The clamping sleeves (6q) must therefore be installed in such a way that the slits in the clamping sleeve face the slits in the intermediate disk (3q). See fig. Diaphragm on dosing-head side.

10.7.3 Fitting the dosing head

- Fit the dosing head and cross-tighten the dosing head screws using a torque wrench.

Note See section Start-up/shutdown for subsequent start-up!

Related information

8.1 Initial start-up/subsequent start-up

10.7.4 Filling the double diaphragm with separating agent

After a diaphragm has broken, the ball non-return valve must be cleaned before the diaphragm is filled with separating agent. Only clean the ball non-return valve after a diaphragm breakage!

Caution

Pump with double diaphragm: After the diaphragm has been replaced, refill the separating agent between the diaphragms.

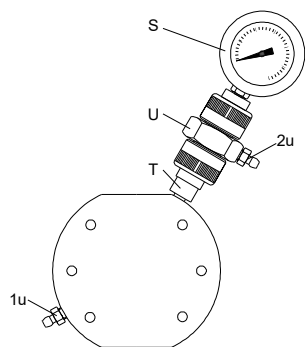

TM036467

Dosing head with double diaphragm

Pos.	Components
S	Contact pressure gauge
T	Ball non-return valve
U	Connection piece
1u	Filling screw
2u	Deaeration screw

- Set the stroke-length adjustment knob of the pump to 0 %.
- Open the filling screw (1u) and deaeration screw (2u) by one turn.
- Connect the filling hose to the nipple of the filling screw (1u) and, using the dosing syringe, inject the correct amount of paraffin oil that is specified in the table below.
- Close the filling screw (1u), but leave the deaeration screw (2u) open.
- Start the pump with a system counter-pressure and stroke-length setting of 40 %.
- Only close the deaeration screw (2u) when the separating agent stops flowing (after 5 to 10 minutes).

Note After a few operating hours, especially if the pressure of the pressure gauge is increasing, deaerate the double diaphragm again.

Quantity of paraffin oil required for dosing pumps with a double diaphragm (per dosing head)

Pump model	Filling quantity [ml]
DMH 251-253	4
DMH 254	6
DMH 255	8
DMH 257	10

Note For product numbers of double-diaphragm filling components, see "Service kit catalogue" on www.grundfos.com

10.7.5 Filling with gear oil

Caution Risk of leaking oil and damage caused by oil loss! For each oil change, a new flat gasket (1b) must be fitted!

- Check that the locking screw (B) is tightened.
- Slacken and remove the oil-filling screw (F).
- Set the stroke-length adjustment knob (L) to "0".
- Slowly add the hydraulic oil through the oil-filling opening (F) until the oil reaches the mark on the oil dipstick.
- Wait 30 minutes.
- Let the pump run for approx. 5 minutes with a stroke-length setting of 0 %.
- Let the pump run for approx. 10 minutes with a stroke-length setting of 40 %.

10.7.6 Checking the oil level

- Switch off the pump, check the oil level and add oil, if necessary.
- Refit the oil-filling screw (F).

After initial start-up and after each time the diaphragm is changed, tighten the dosing head screws.

Caution After approximately 6-10 operating hours or two days, cross-tighten the dosing head screws using a torque wrench.

Torques

Pump model	Torque [Nm]
DMH 251, 10 bar	8-10
DMH 251, 16 bar	10-12
DMH 251, 25 bar	13-15
DMH 252	8-10
DMH 253	10-12
DMH 254	50-54
DMH 255	50-54
DMH 257	50-54

10.7.7 Cleaning the ball non-return valve

Note Only clean the ball non-return valve after a diaphragm breakage!

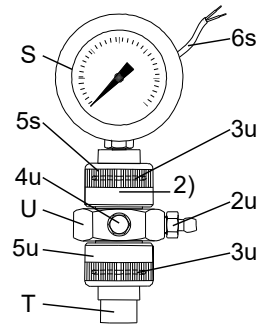

Contact pressure gauge

Pos.	Components
S	Contact pressure gauge
5s	Union nut
6s	Contact output
T	Ball non-return valve
U	Connection piece
2u	Deaeration screw
3u	O-rings
4u	Connection for earth cable
5u	Union nut
2)	or locking unit (instead of contact pressure gauge and its connection)

Removing the ball non-return valve and contact pressure gauge

1. For pumps and pressure gauges in explosion-proof version, unscrew the earth cable (4u).
2. Hold the connection piece (U) with a screwdriver and unscrew the union nut (5u).
3. Unscrew the ball non-return valve (T) from the dosing head.

Cleaning the ball non-return valve

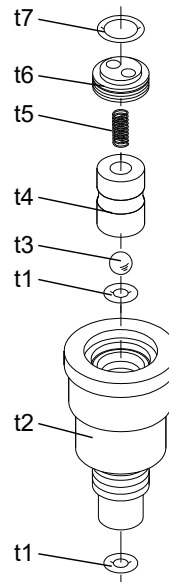

Ball non-return valve

Pos.	Components
t1	O-ring
t2	Ball non-return valve body
t3	Ball
t4	Spring sheath
t5	Pressure spring
t6	Screw part
t7	O-ring

1. Unscrew the screw part (t6) using round pliers.
2. Clean all parts. Replace faulty parts by new ones.
3. Re-assemble the ball non-return valve.
4. Refit the ball non-return valve (T).
5. Screw the contact pressure gauge (S) and connection piece (U) back on.
6. For pumps and pressure gauges in explosion-proof version, screw the earth cable (4u) back on.

Caution Tighten the ball non-return valve and connection piece by hand only.

TM036453

TM036476

11. Fault finding chart



Warning

Actions that are taken to correct faults on the pump and that are not described in this manual, must only be carried out by personnel authorised by Grundfos!

Fault	Diagnosis	Cause	Remedy
No dosing flow even at a low counter-pressure. (Pump is running without any noise).	No motor sound or vibrations. Fan is not rotating.	Motor is not running.	Connect the power supply or replace the motor, if blown.
	When the oil-filling screw (F) is removed, use the dipstick to observe a calm oil surface. There is no "sloshing".	Motor runs, but the eccentric shaft is not rotating. No piston movement. Spiral pin or motor shaft broken.	Remove the motor and eccentric shaft. Replace damaged parts.
	Oil level too low. See oil dipstick (F). No reaction of the overpressure valve if the suction line is closed.	Not enough oil in the pump. Air is penetrating the piston flange through the control holes.	Fill in oil. Deaerate the pump, see section Start-up/shutdown.
	No dosing flow on the discharge side.	Dosing head is not filled. Suction line empty. Tank empty.	Deaerate the dosing head. Fill/exchange the tank on the suction side.
No dosing flow even at a low counter-pressure. (Pump is running noisily although the overpressure valve reacted).	The overpressure valve reacts independently of the dosing flow adjustment (10 % to 100 %).	Valve on discharge side closed.	Open the valve.
		Counter-pressure is higher than the adjusted pressure at the overpressure valve.	Adjust the overpressure valve higher, but only if the pump is designed for this. Never block the overpressure valve.
		Discharge valve is installed in the opposite direction of the flow. Observe the arrow on the valve.	Install the discharge valve correctly.
		Valve on suction side closed.	Open the valve.
	The diaphragm protection system (AMS) responds. The overpressure valve reacts independently of the dosing flow adjustment (10 % to 100 %).	Suction filter obstructed.	Clean the suction filter. Replace, if necessary.
		Suction valve jammed (does not open).	Dismantle and check the suction valve.
		Suction valve has a too strong spring.	Use the fitting spring, or use double ball valve for checking.
		Suction valve is installed in the opposite direction of the flow. Observe the arrow on the valve.	Install the suction valve correctly.
	The diaphragm protection system (AMS) responds. The overpressure valve reacts at 100 % dosing flow. When reducing the flow ~10 % to 20 %, the overpressure valve does not react any more.	Dosing head is not completely deaerated.	Fill the dosing head completely.
		Pump is cavitating (dosing liquid with too high viscosity; dosing liquid with too high steam pressure at operating temperature = degassing of the liquid; suction lift too high; wrong design of the system on suction side).	Use a gear with a low stroke number; use valves with bigger nominal width; realise positive inlet pressure.
Diaphragm broken (not enough oil in the enclosure of the pump; piston flange).		Clean and grease well all parts using oil according to regulations. Then install a new diaphragm.	
Pump does not dose or pressure relief valve opens.	Discharge valve of pump is clogged or ball guide in the valve is worn due to corrosive or abrasive media.	Uninstall the discharge valve. Dismantle and clean, or if the bars of the ball guide are worn, replace the valve.	

Fault	Diagnosis	Cause	Remedy
Dosing flow too small.	Suction valve: During the discharge stroke, the dosing liquid flows back into the suction line.	Suction/discharge valves dirty or leaky.	Clean or replace valves.
	Discharge valve: During the suction stroke, the dosing liquid flows back into the dosing head. The pump takes in less.		
	Dosing flow depends very much on the pressure. If the counter-pressure is low, the dosing flow increases considerably. If the stroke frequency rises, the dosing flow increases excessively.	Too much clearance between piston and slide valve, or the stroke frequency of the pump is too low (too much slip).	Replace the piston and piston slide valves. Use other hydraulic oil with a higher viscosity (mainly for frequency converter operation and higher counter-pressures).
	Pressure gauge in discharge line.	Counter-pressure has seriously increased. Overpressure valve is adjusted too low.	Readjust the zero point. Correct the setting of the pressure relief valve.
Pump doses too much.	Especially at stroke frequencies below 15 strokes/min., e.g. frequency converter operation.	Degassing valve (M) is not working properly.	Replace the degassing valve (M) or, if necessary, replace with Ø8 ball.
	Pressure gauge in discharge line.	Counter-pressure has seriously dropped.	Readjust the zero point.
	Heavy overdose.	Inlet pressure of suction line higher than counter-pressure of discharge line.	Install a pressure-loading valve.
	Overdosing at high dosing flow settings and flows.	Too big dynamic in the suction line.	Install a pulsation damper on the suction side.

Related information

[8.1 Initial start-up/subsequent start-up](#)

12. Dosing curves

The dosing curves in the appendix are trend curves. See appendix Dosing curves.

They apply to:

- performance of single pump (the flow rate is doubled for the double pump)
- water as dosing medium
- zero point of pump Q_0 for specified pressure, see table below
- standard pump version.

Abbreviation	Description
Q	Dosing flow
Q_0	Zero point of the pump
h	Stroke length

Related information

[A.1. Dosing curves](#)

13. Disposing of the product

This product or parts of it must be disposed of in an environmentally sound way.

1. Use the public or private waste collection service.
2. If this is not possible, contact the nearest Grundfos company or service workshop.



The crossed-out wheellie bin symbol on a product means that it must be disposed of separately from household waste. When a product marked with this symbol reaches its end of life, take it to a collection point designated by the local waste disposal authorities. The separate collection and recycling of such products will help protect the environment and human health.

See also end-of-life information at www.grundfos.com/product-recycling.

A.1. Dosing curves

DMH 251

DMH 2,2-25 (50 Hz) $Q_0 = 20$ bar

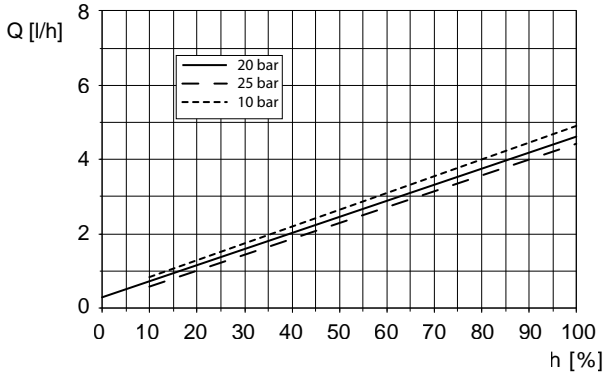

DMH 2,2-25 (60 Hz) $Q_0 = 20$ bar

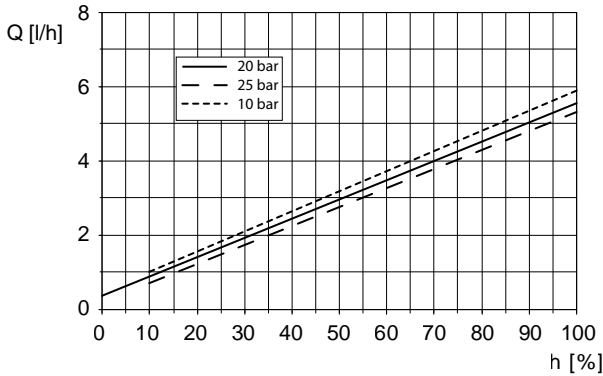

DMH 2,3-16 (50 Hz) $Q_0 = 10$ bar

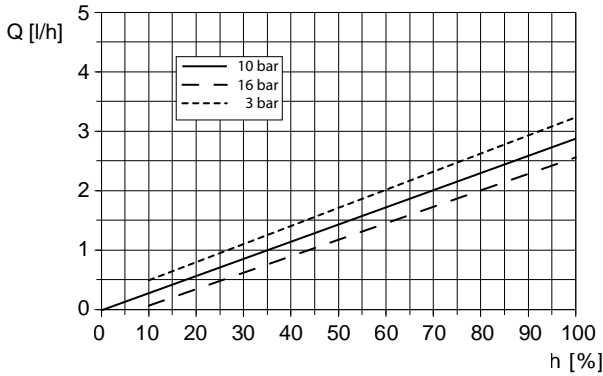

DMH 2,3-16 (60 Hz) $Q_0 = 10$ bar

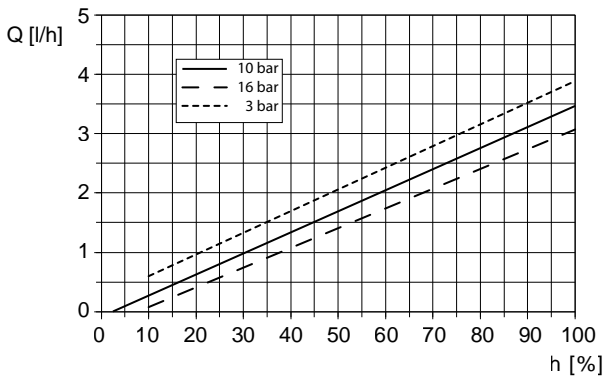

DMH 2,4-10 (50 Hz) $Q_0 = 3$ bar

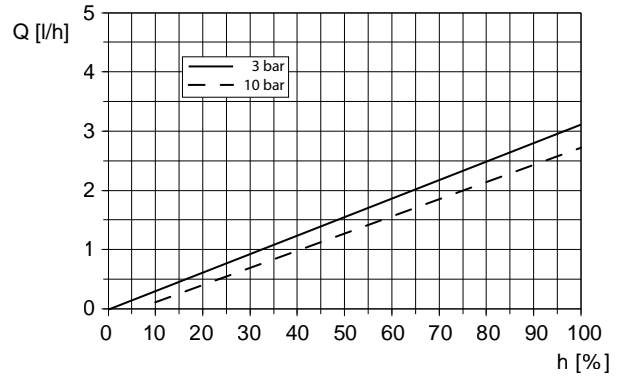

DMH 2,4-10 (60 Hz) $Q_0 = 3$ bar

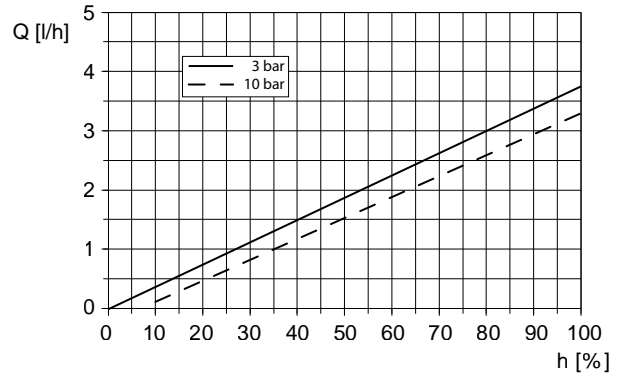

DMH 4,5-25 (50Hz) $Q_0 = 20$ bar

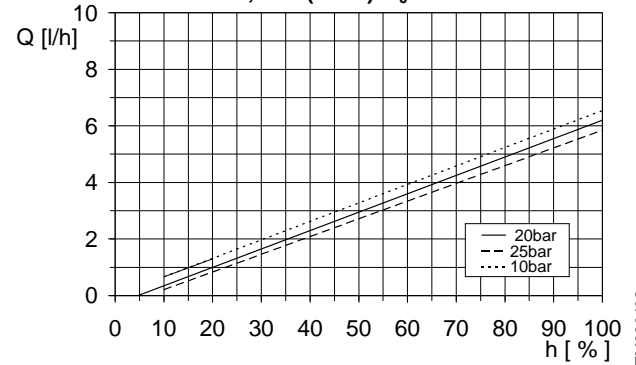

DMH 4,5-25 (60Hz) $Q_0 = 20$ bar

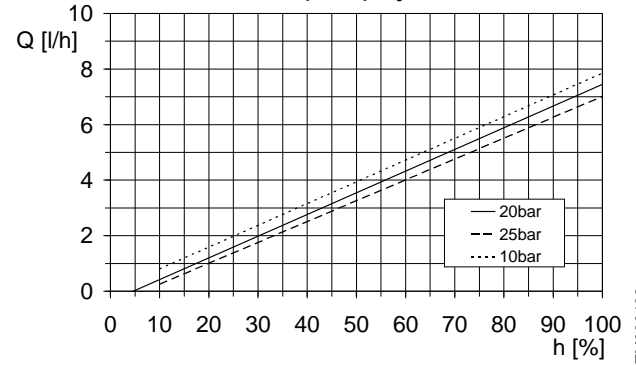

DMH 4,9-16 (50Hz) $Q_0 = 10\text{bar}$

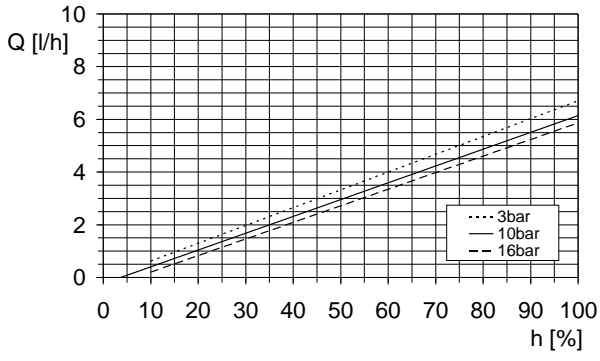

DMH 11-25 (50Hz) $Q_0 = 20\text{bar}$

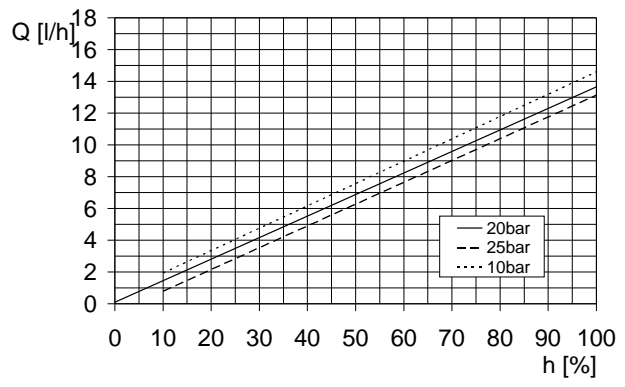

DMH 4,9-16 (60Hz) $Q_0 = 10\text{bar}$

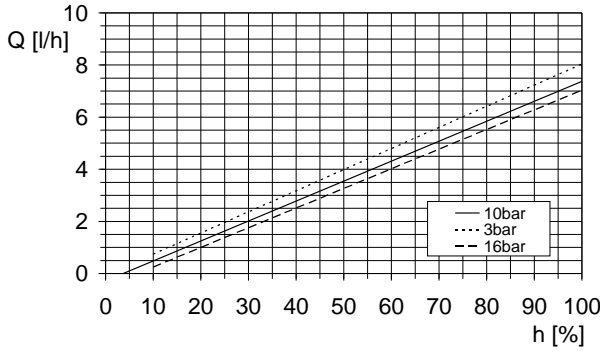

DMH 11-25 (60Hz) $Q_0 = 20\text{bar}$

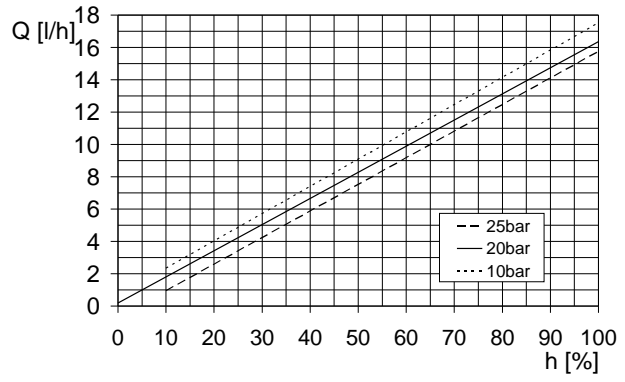

DMH 5-10 (50Hz) $Q_0 = 3\text{bar}$

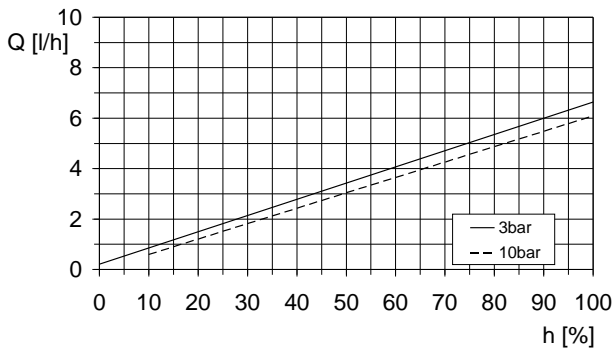

DMH 12-16 (50Hz) $Q_0 = 10\text{bar}$

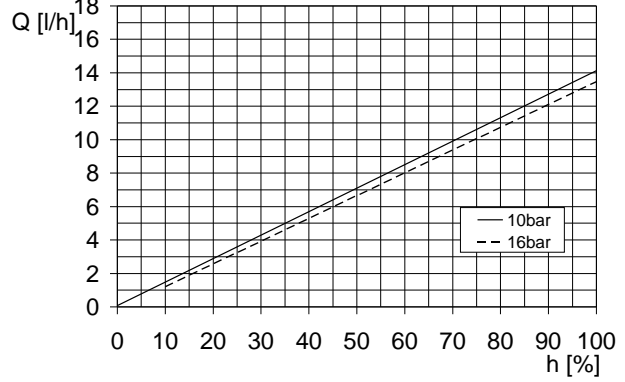

DMH 5-10 (60Hz) $Q_0 = 3\text{bar}$

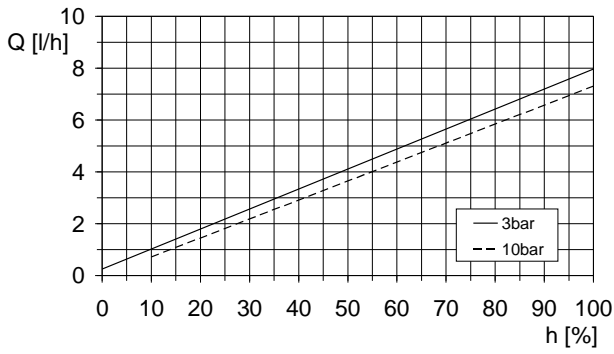

DMH 12-16 (60Hz) $Q_0 = 10\text{bar}$

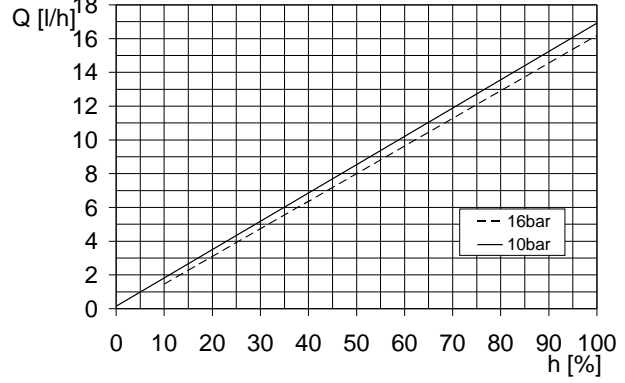

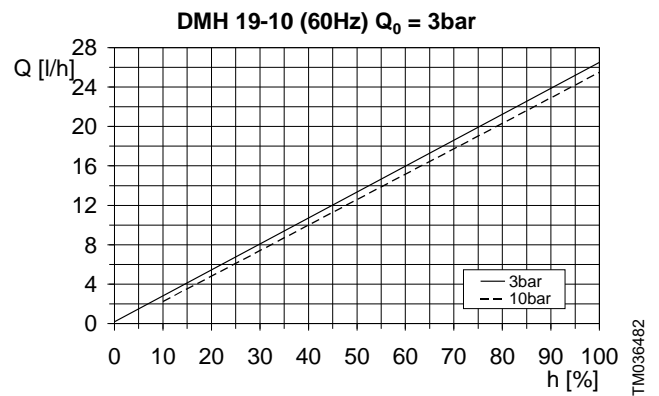
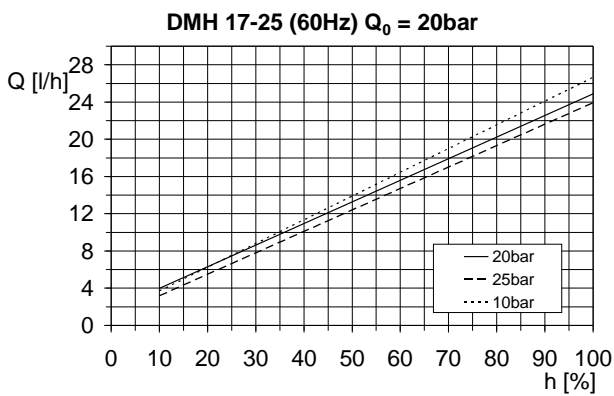
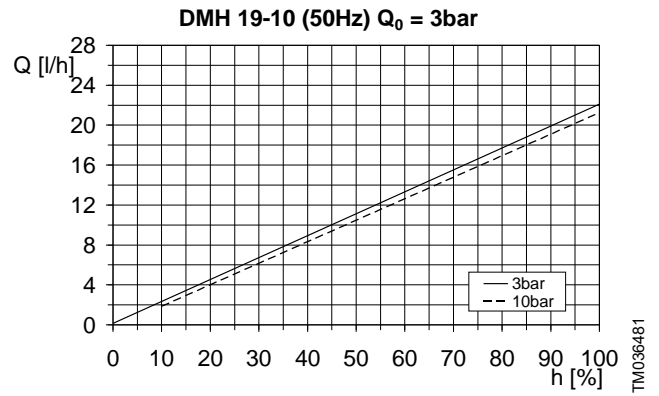
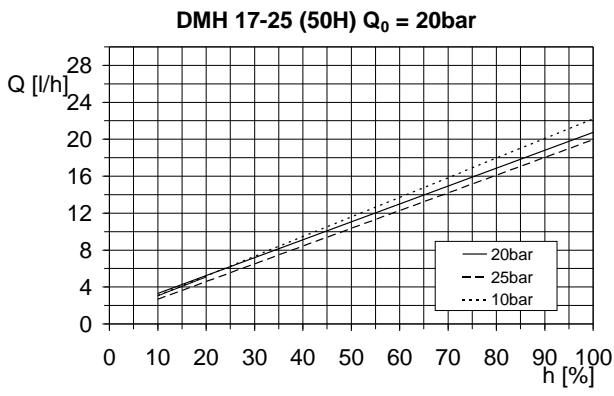
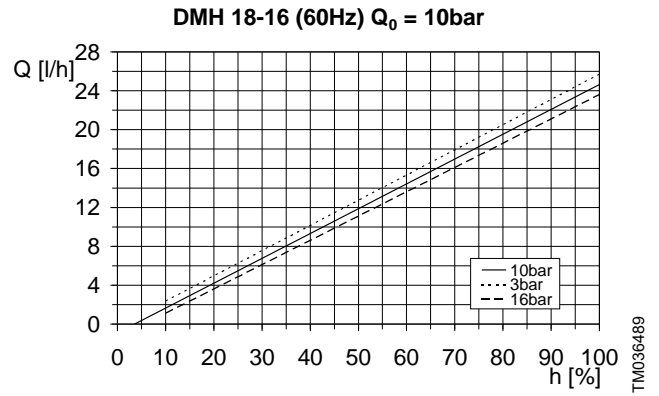
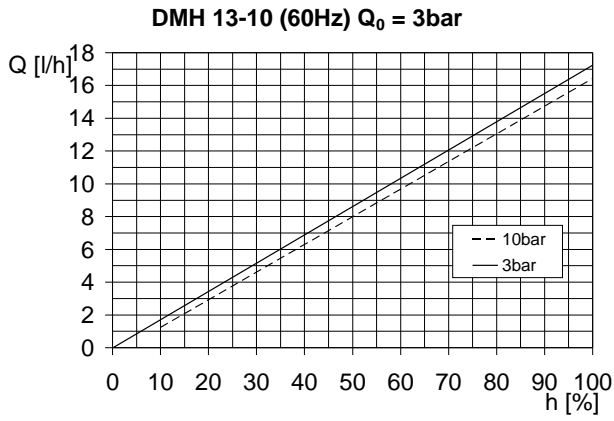
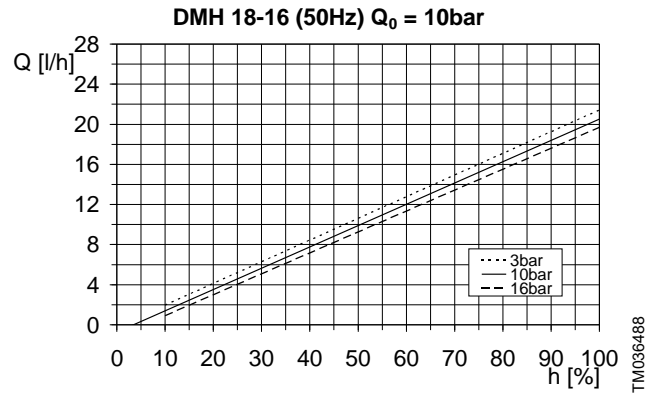
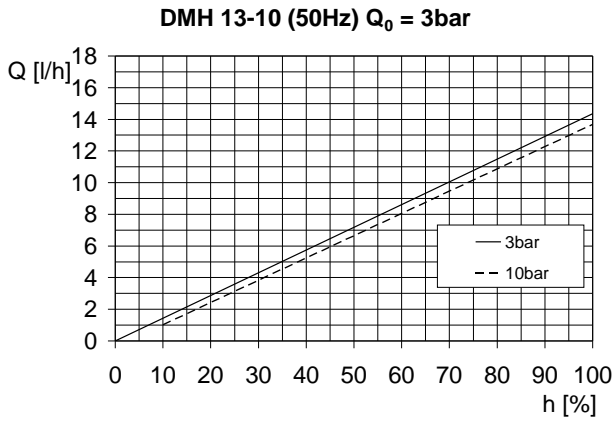

DMH 21-25 (50Hz) $Q_0 = 20\text{bar}$

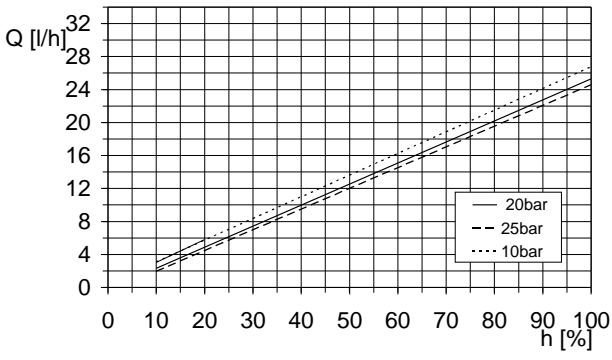

TM036498

DMH 23-16 (50Hz) $Q_0 = 10\text{bar}$

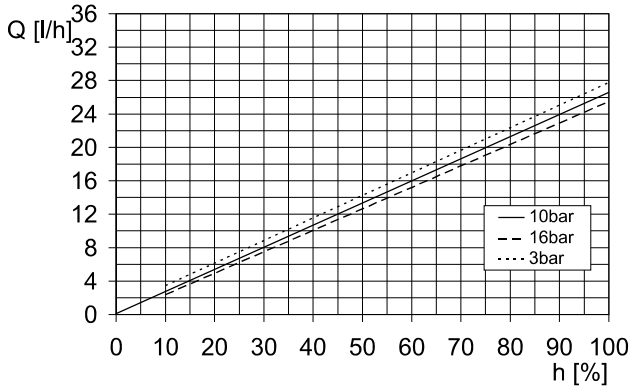

TM036490

DMH 23-16 (60Hz) $Q_0 = 10\text{bar}$

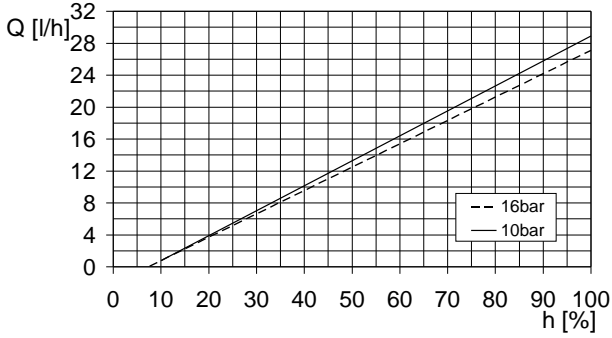

TM036491

DMH 24-10 (50Hz) $Q_0 = 3\text{bar}$

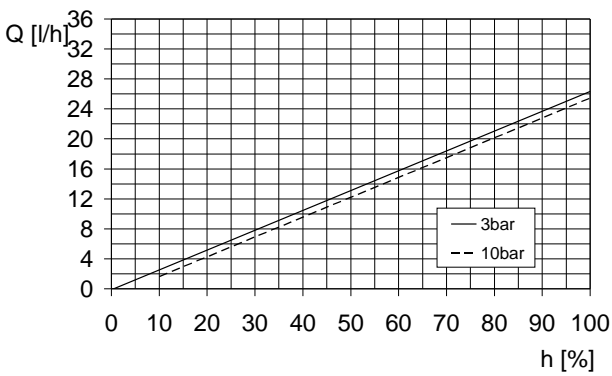

TM036483

DMH 252

DMH 10-16 (50Hz) $Q_0 = 10\text{bar}$

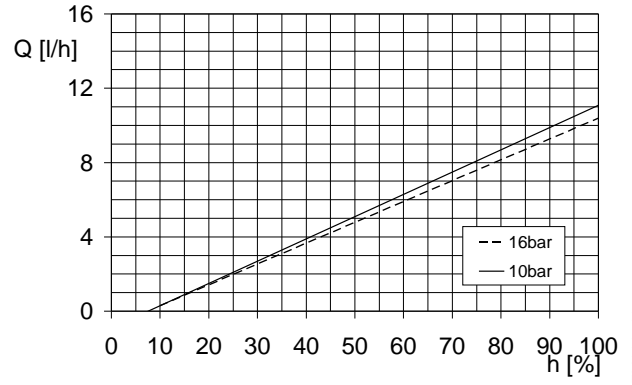

TM036506

DMH 10-16 (60Hz) $Q_0 = 10\text{bar}$

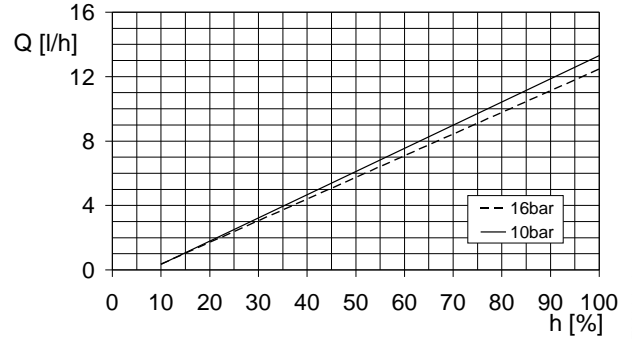

TM036507

DMH 11-10 (50Hz) $Q_0 = 3\text{bar}$

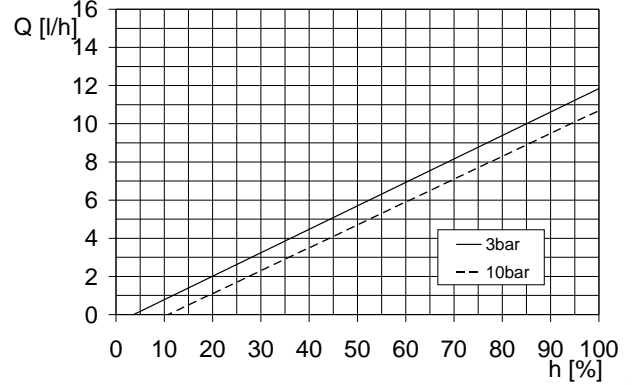

TM036499

DMH 11-10 (60Hz) $Q_0 = 3\text{bar}$

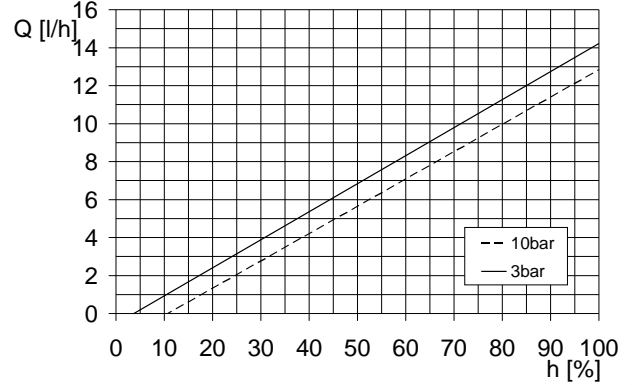

TM036500

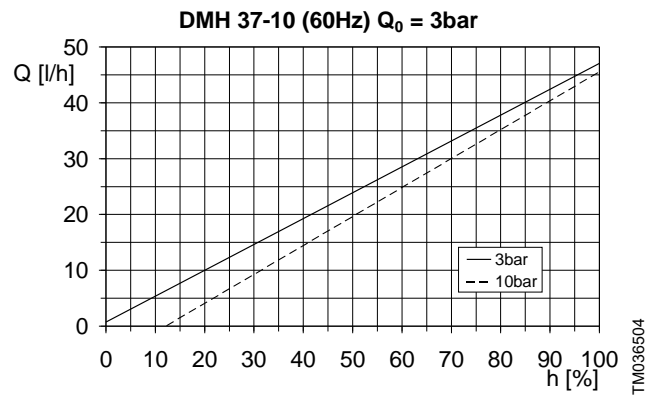
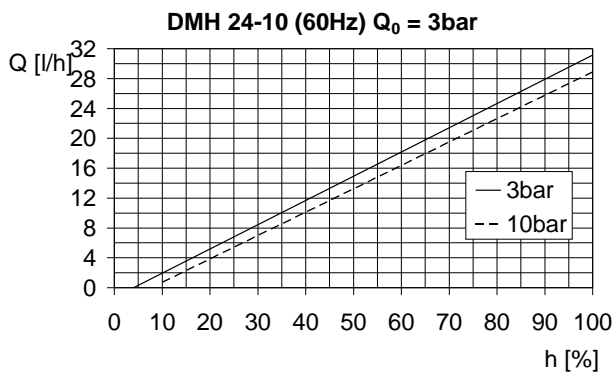
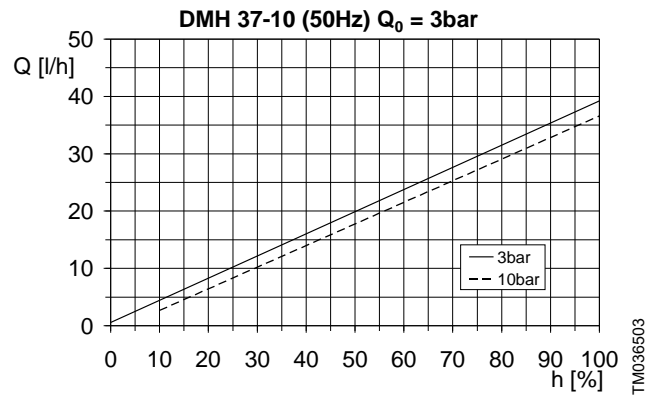
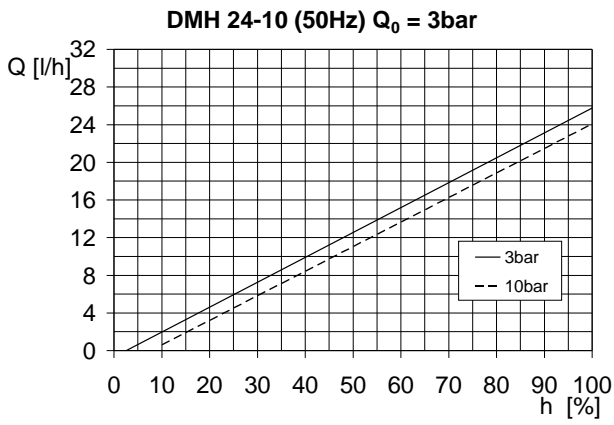
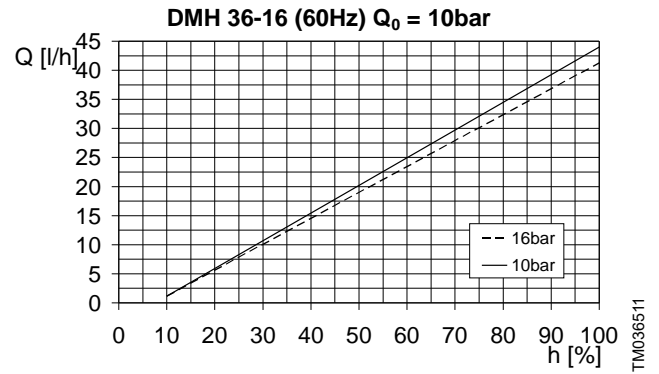
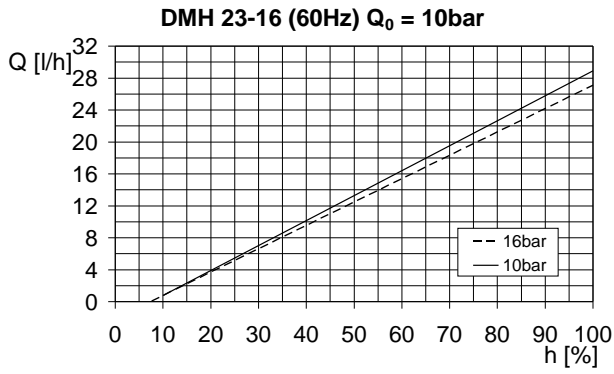
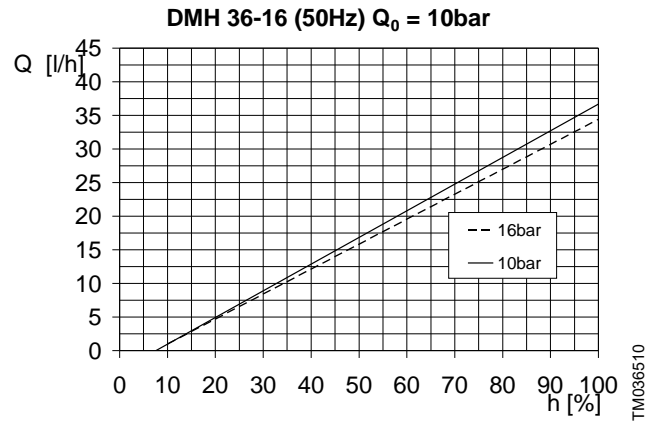
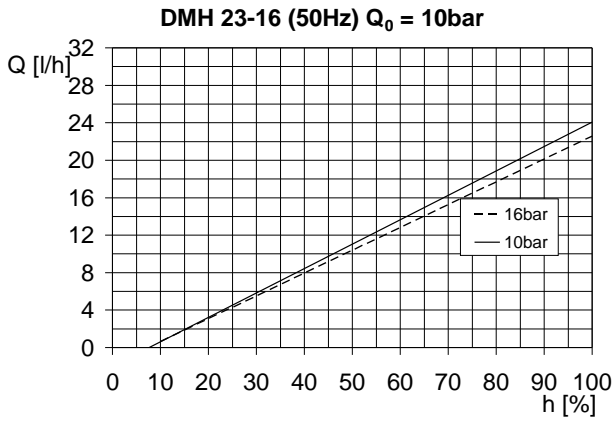

DMH 45-16 (50Hz) $Q_0 = 10\text{bar}$

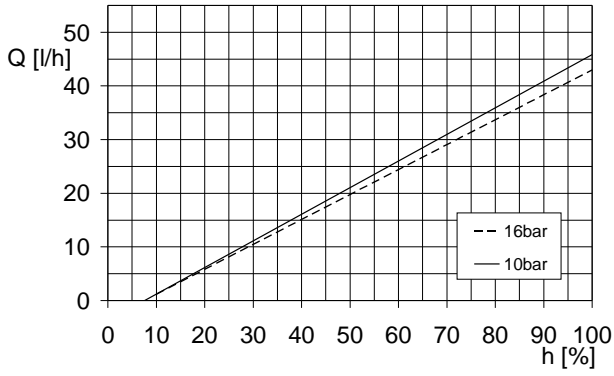

DMH 253

DMH 21-10 (50Hz) $Q_0 = 3\text{bar}$

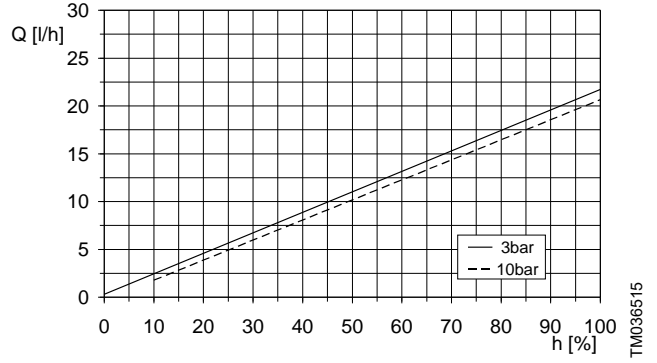

DMH 45-16 (60Hz) $Q_0 = 10\text{bar}$

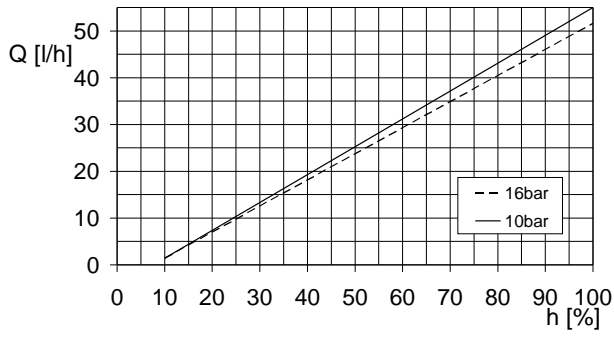

DMH 21-10 (60Hz) $Q_0 = 3\text{bar}$

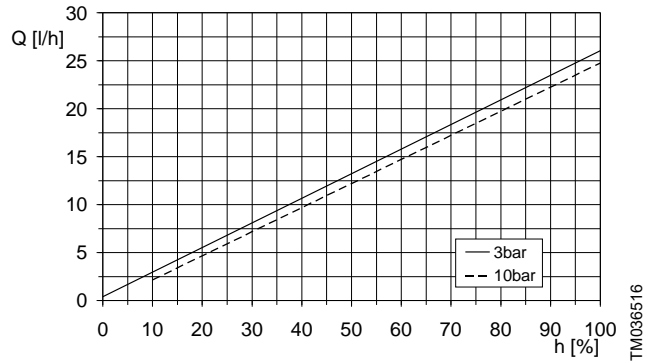

DMH 46-10 (50Hz) $Q_0 = 3\text{bar}$

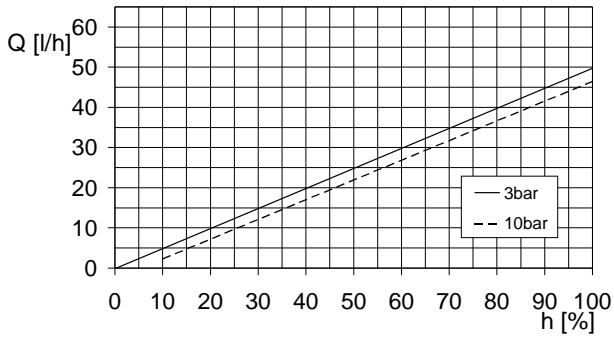

DMH 43-10 (50Hz) $Q_0 = 3\text{bar}$

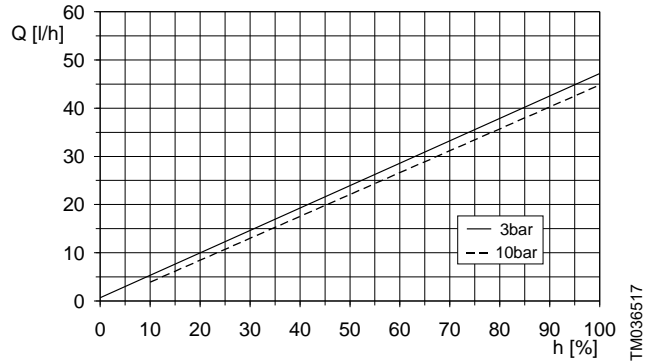

DMH 54-16 (50Hz) $Q_0 = 10\text{bar}$

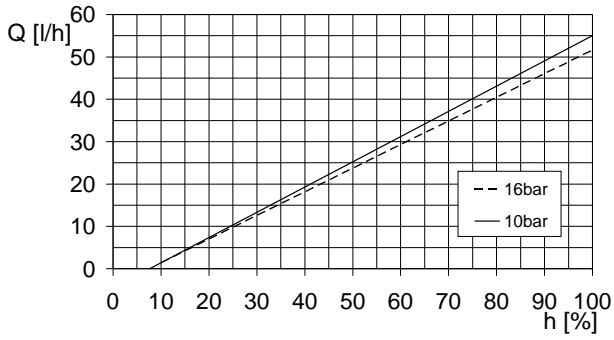

DMH 43-10 (60Hz) $Q_0 = 3\text{bar}$

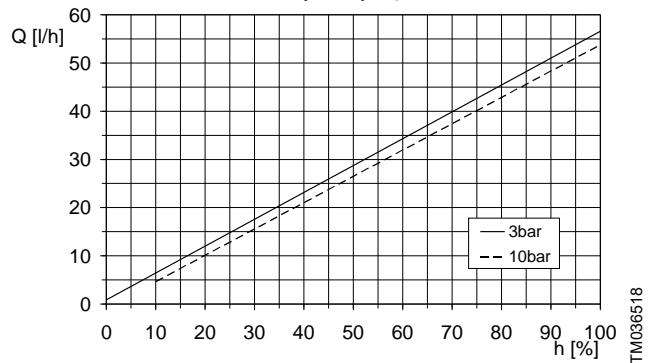

DMH 67-10 (50Hz) $Q_0 = 3\text{bar}$

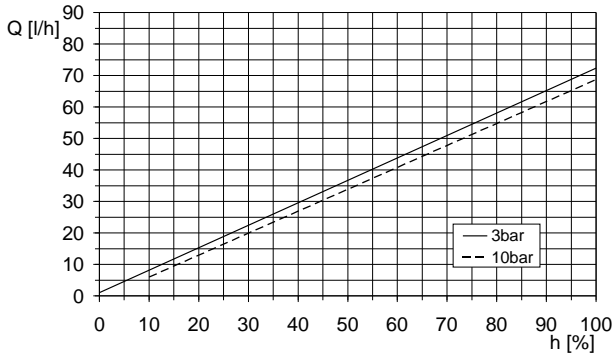

TM036519

DMH 100-10 (50Hz) $Q_0 = 3\text{bar}$

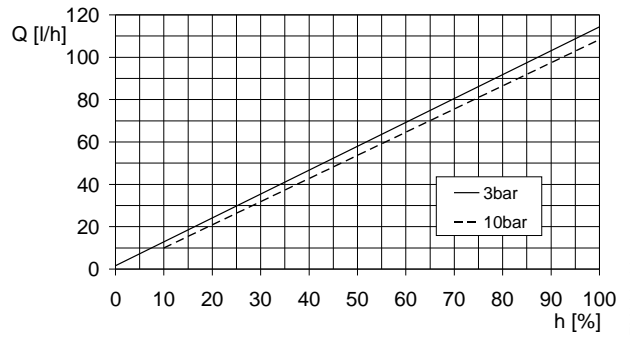

TM036523

DMH 67-10 (60Hz) $Q_0 = 3\text{bar}$

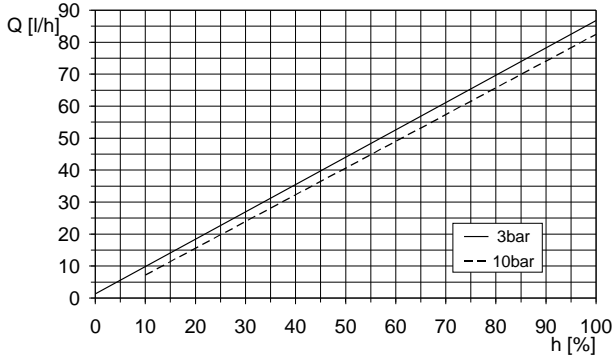

TM036520

DMH 254

DMH 46-16 (50 Hz) $Q_0 = 10\text{bar}$

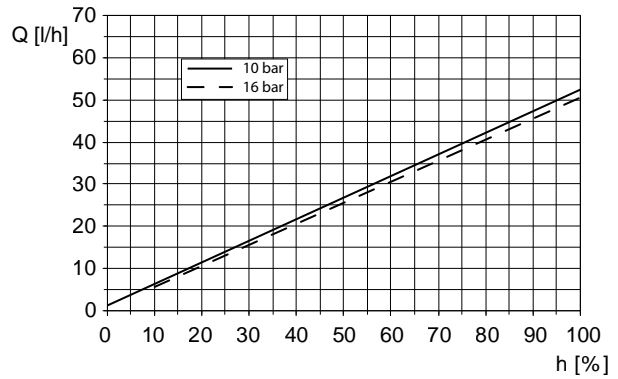

TM074573

DMH 83-10 (50Hz) $Q_0 = 3\text{bar}$

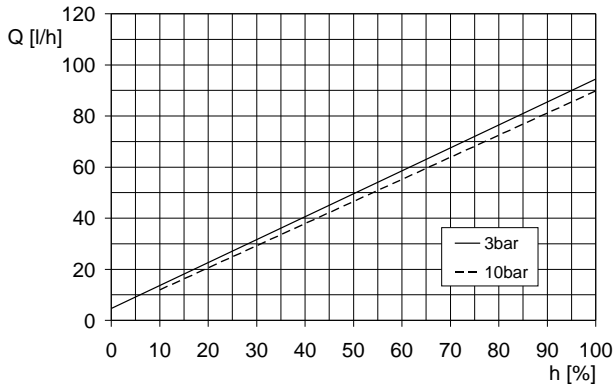

TM036521

DMH 46-16 (60 Hz) $Q_0 = 10\text{bar}$

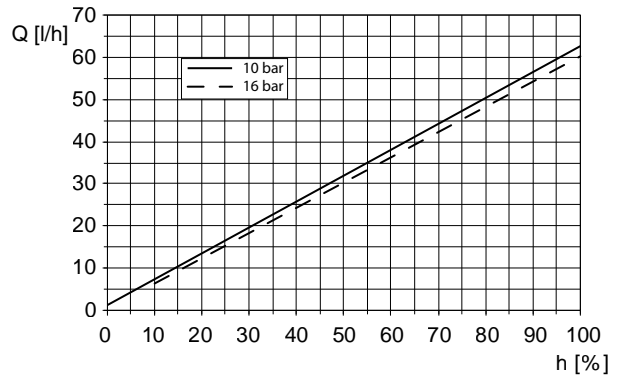

TM074574

DMH 83-10 (60Hz) $Q_0 = 3\text{bar}$

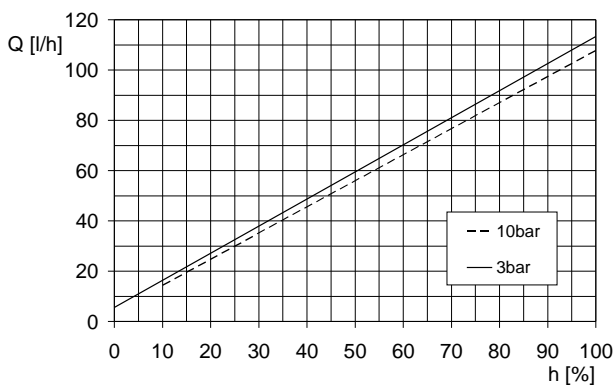

TM036522

DMH 50-10 (50 Hz) $Q_0 = 3\text{bar}$

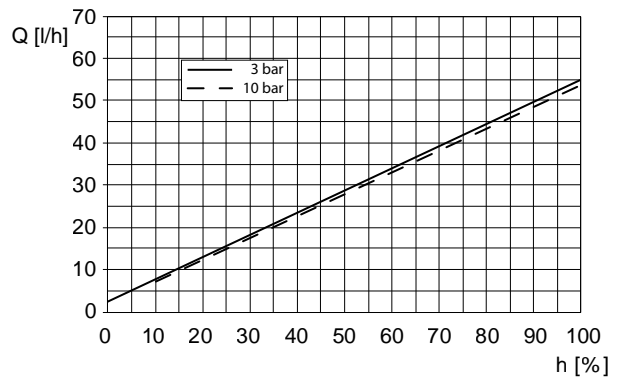

TM074575

DMH 50-10 (60 Hz) $Q_0 = 3 \text{ bar}$

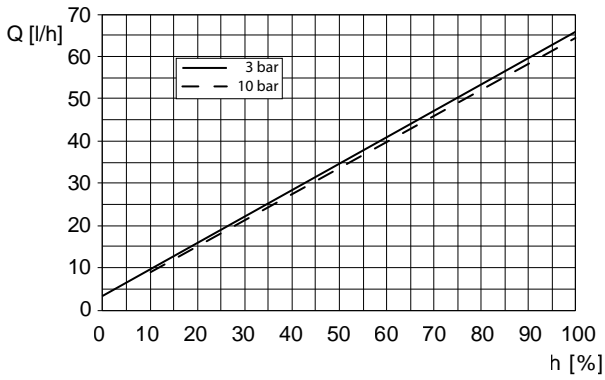

DMH 102-10 (60Hz) $Q_0 = 3 \text{ bar}$

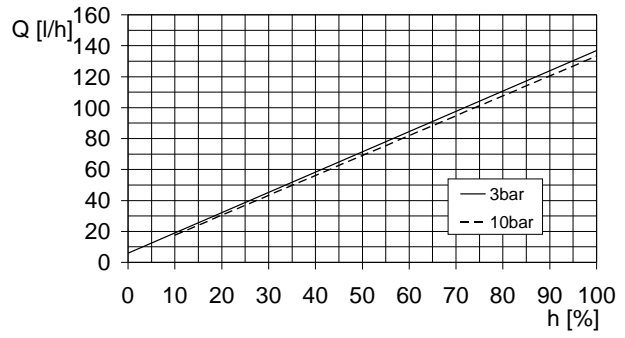

DMH 97-16 (50Hz) $Q_0 = 10 \text{ bar}$

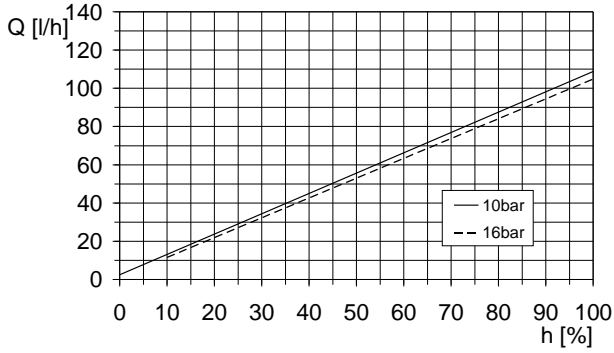

DMH 136-16 (50Hz) $Q_0 = 10 \text{ bar}$

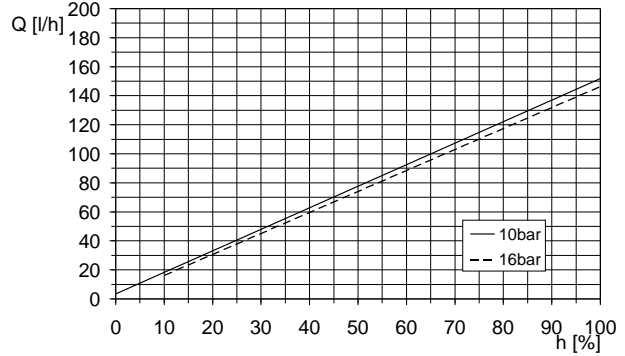

DMH 97-16 (60Hz) $Q_0 = 10 \text{ bar}$

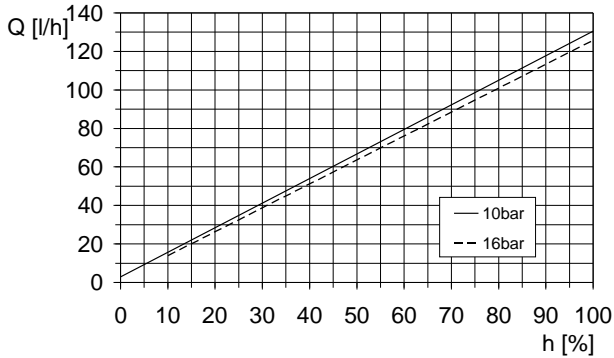

DMH 136-16 (60Hz) $Q_0 = 10 \text{ bar}$

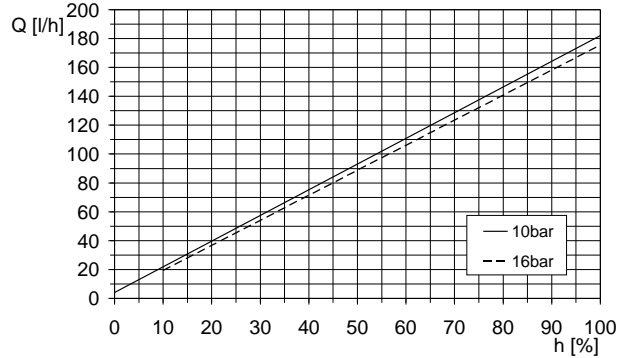

DMH 102-10 (50Hz) $Q_0 = 3 \text{ bar}$

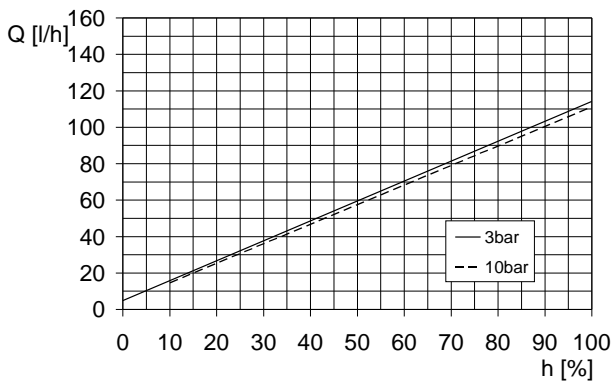

DMH 143-10 (50Hz) $Q_0 = 3 \text{ bar}$

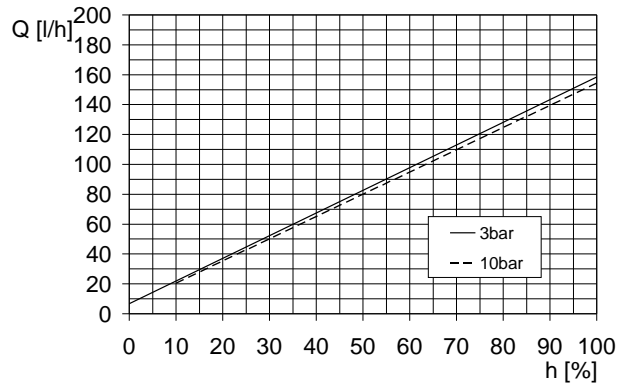

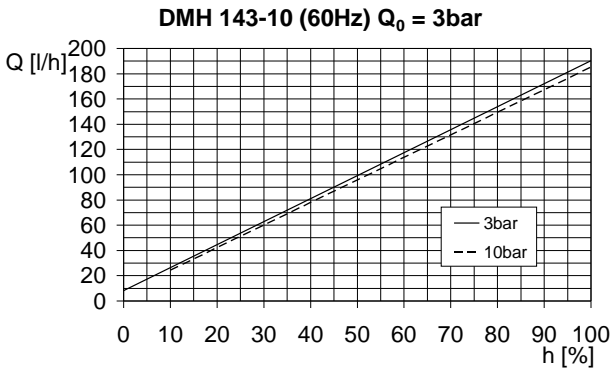

TM036527

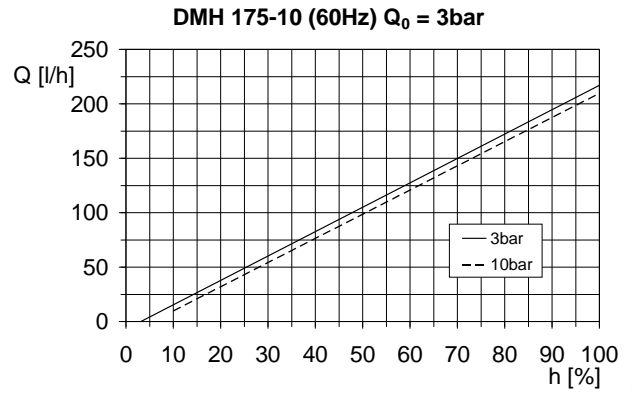

TM036529

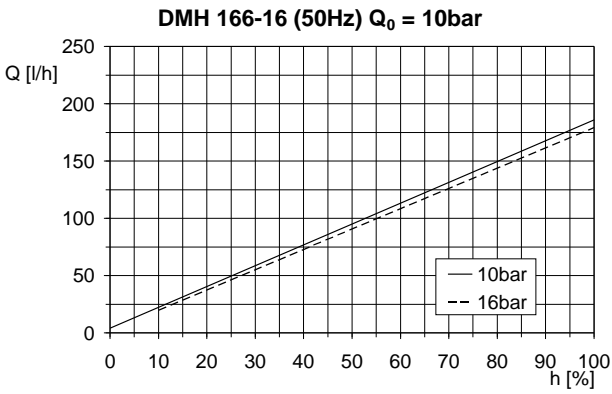

TM036537

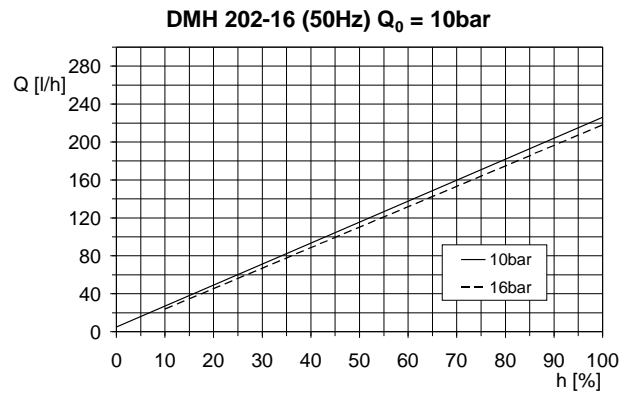

TM036539

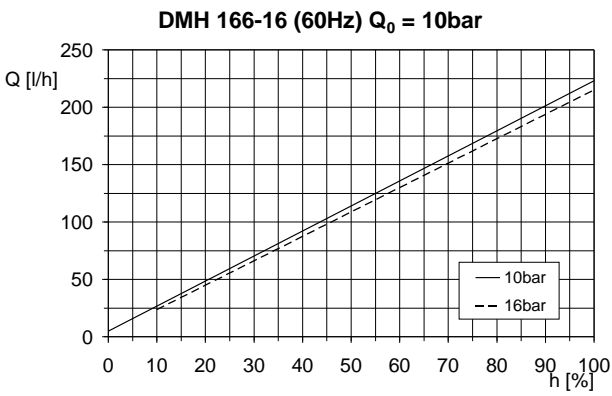

TM036538

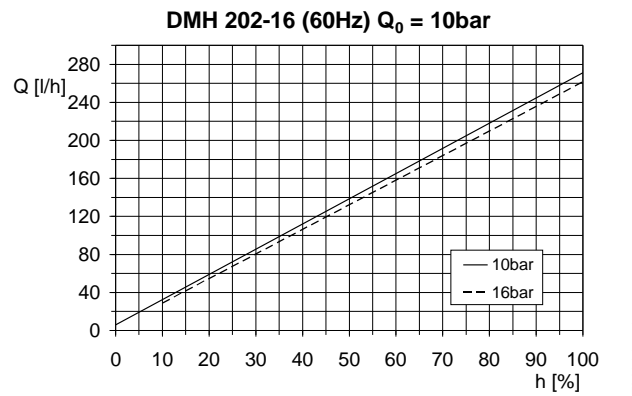

TM036540

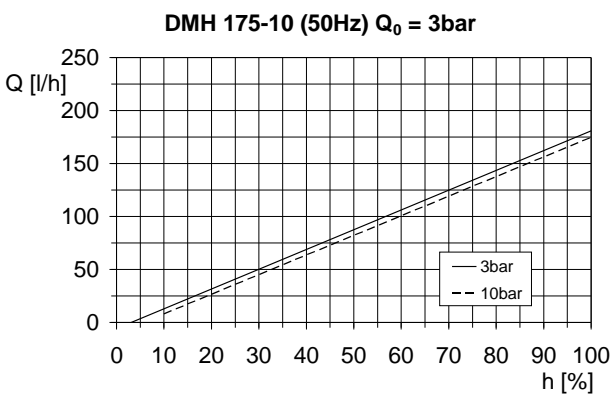

TM036528

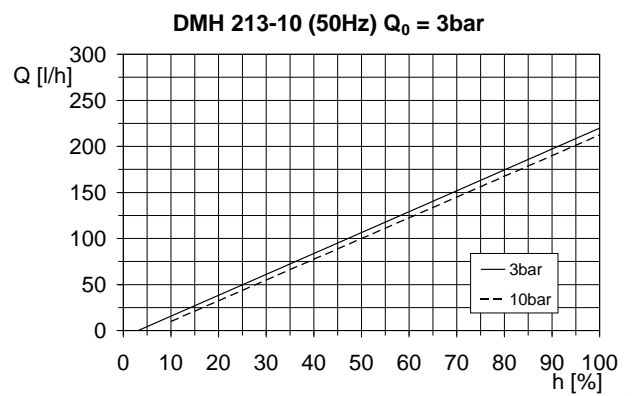

TM036530

DMH 213-10 (60Hz) $Q_0 = 3\text{bar}$

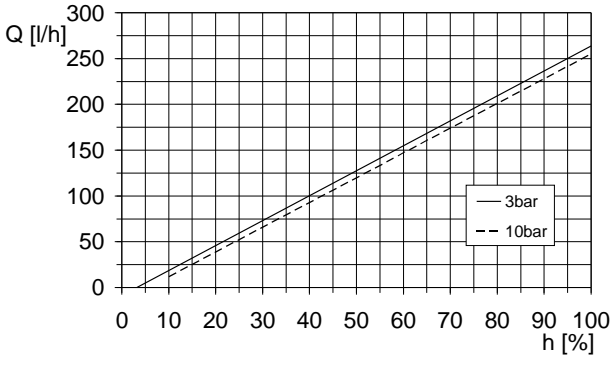

DMH 194-10 (60Hz) $Q_0 = 3\text{bar}$

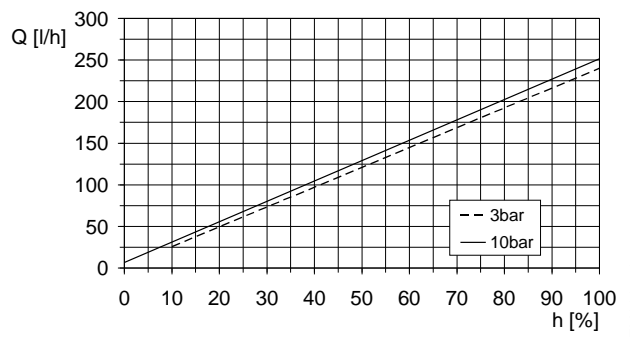

DMH 276-16 (50Hz) $Q_0 = 10\text{bar}$

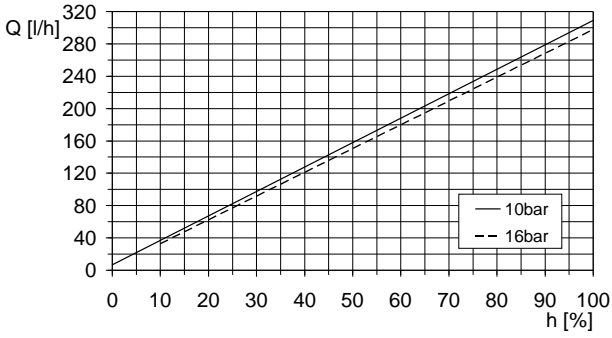

DMH 270-10 (50Hz) $Q_0 = 3\text{bar}$

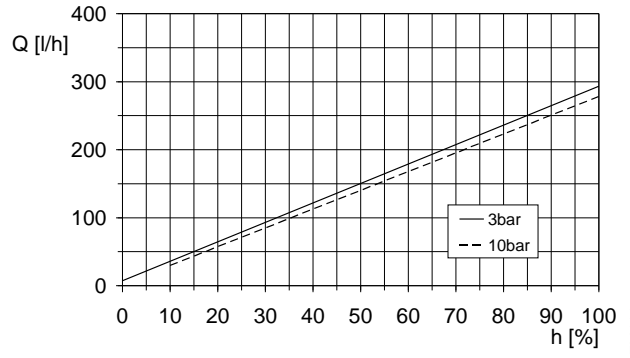

DMH 291-10 (50Hz) $Q_0 = 3\text{bar}$

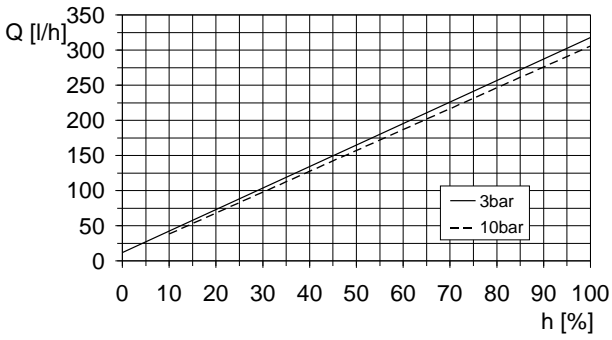

DMH 270-10 (60Hz) $Q_0 = 3\text{bar}$

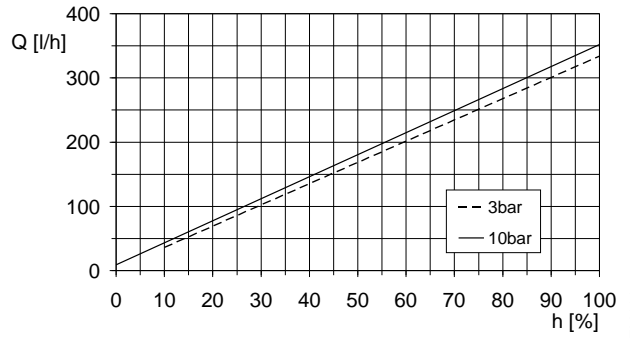

DMH 255

DMH 194-10 (50Hz) $Q_0 = 3\text{bar}$

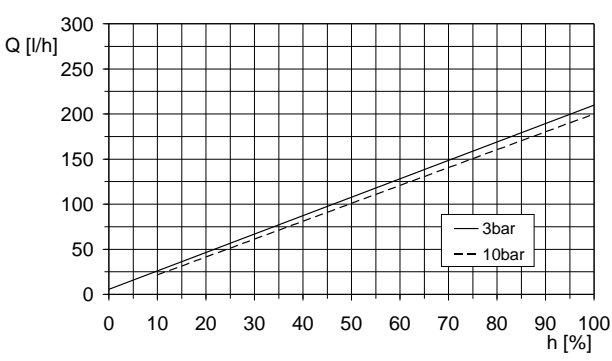

DMH 332-10 (50Hz) $Q_0 = 3\text{bar}$

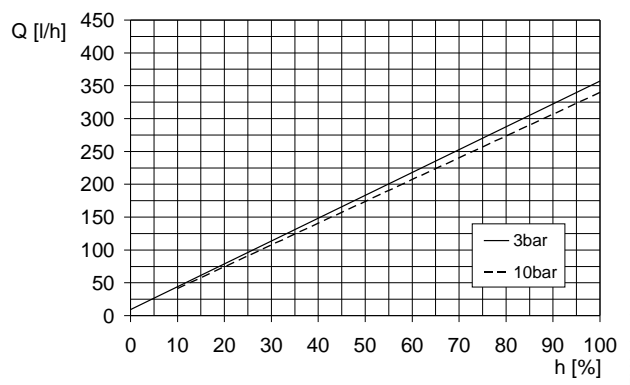

DMH 332-10 (60Hz) $Q_0 = 3\text{bar}$

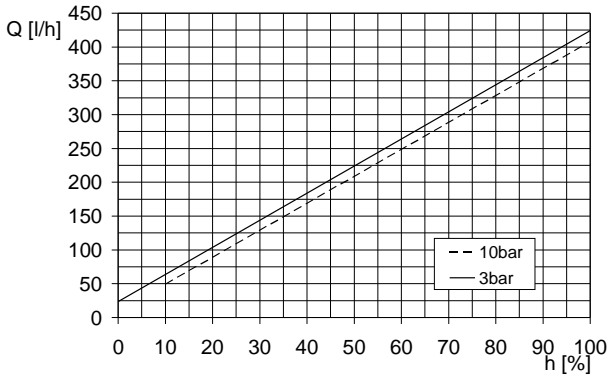

DMH 257

DMH 440-10 (50Hz) $Q_0 = 3\text{bar}$

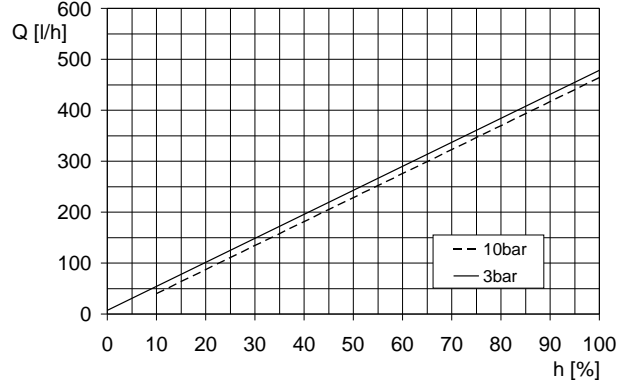

DMH 403-10 (50Hz) $Q_0 = 3\text{bar}$

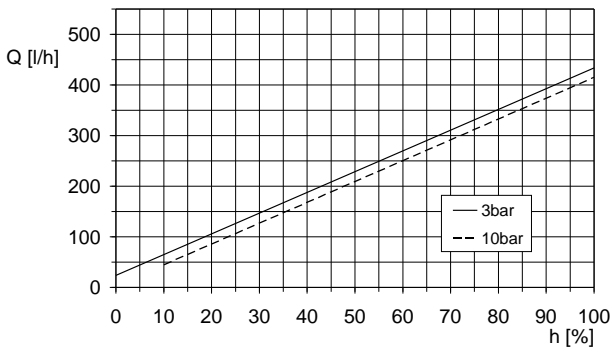

DMH 440-10 (60Hz) $Q_0 = 3\text{bar}$

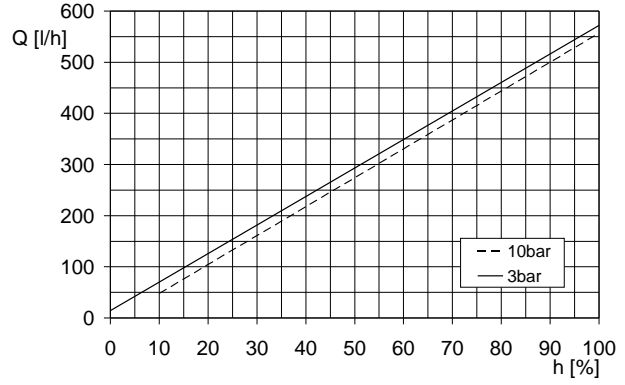

DMH 403-10 (60Hz) $Q_0 = 3\text{bar}$

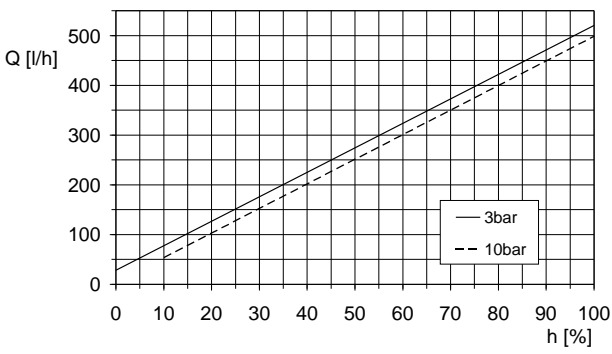

DMH 575-10 (50Hz) $Q_0 = 3\text{bar}$

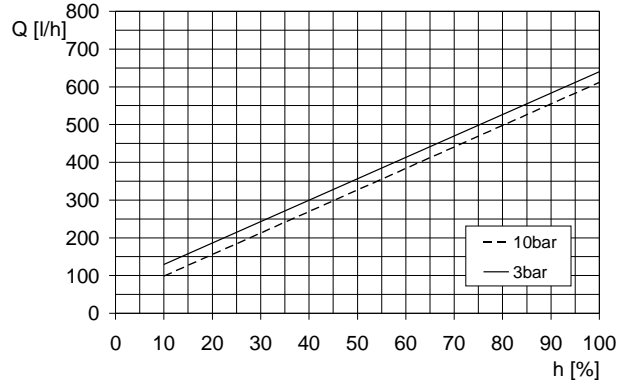

DMH 550-10 (50Hz) $Q_0 = 3\text{bar}$

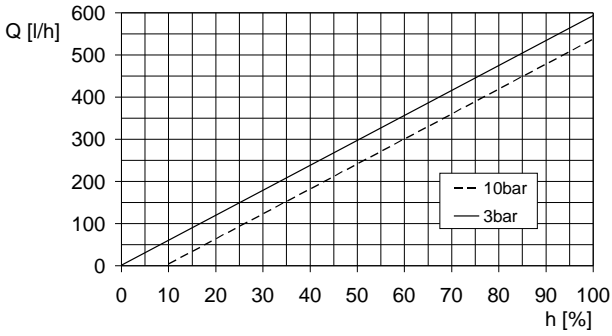

DMH 575-10 (60Hz) $Q_0 = 3\text{bar}$

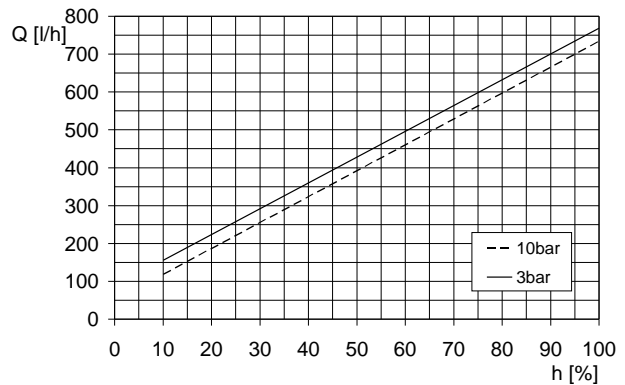

DMH 750-4 (50Hz) $Q_0 = 3\text{bar}$

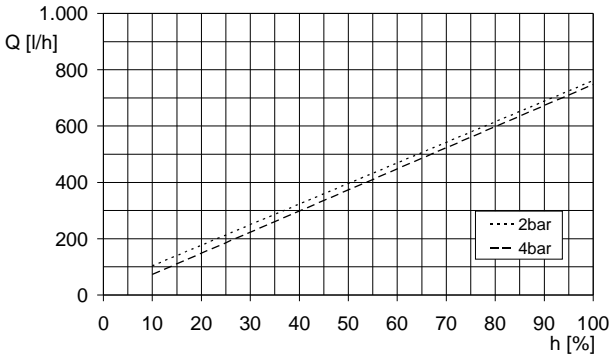

DMH 880-10 (50Hz) $Q_0 = 3\text{bar}$

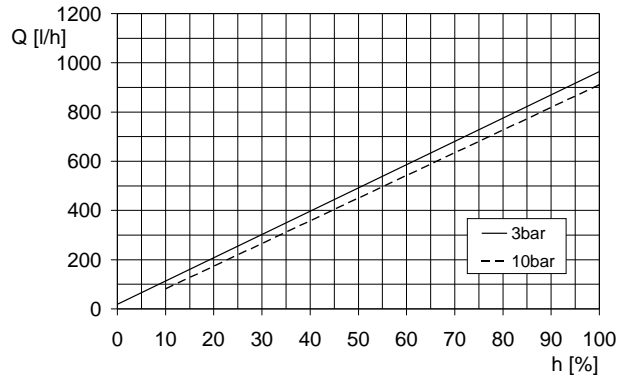

DMH 750-4 (60Hz) $Q_0 = 3\text{bar}$

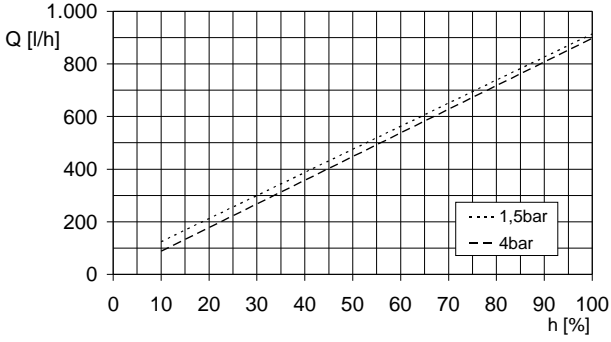

DMH 880-10 (60Hz) $Q_0 = 3\text{bar}$

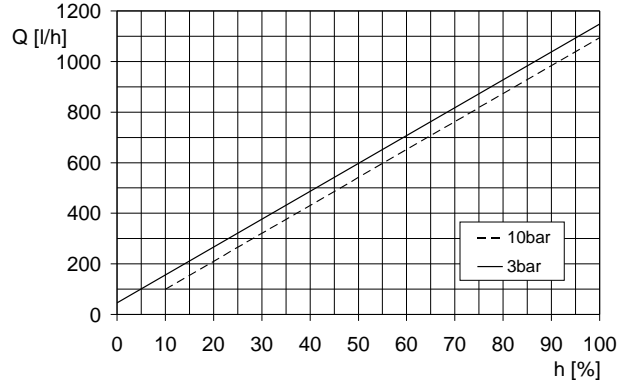

DMH 770-10 (50Hz) $Q_0 = 3\text{bar}$

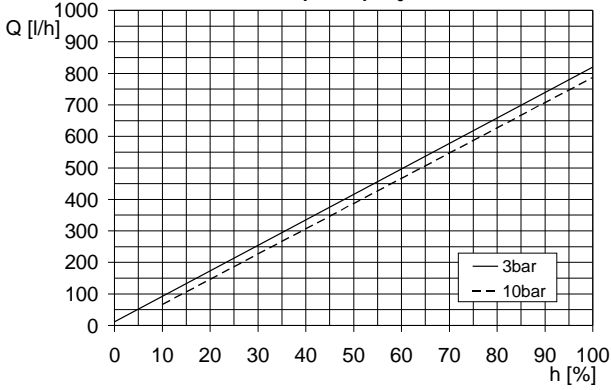

DMH 1150-10 (50Hz) $Q_0 = 3\text{bar}$

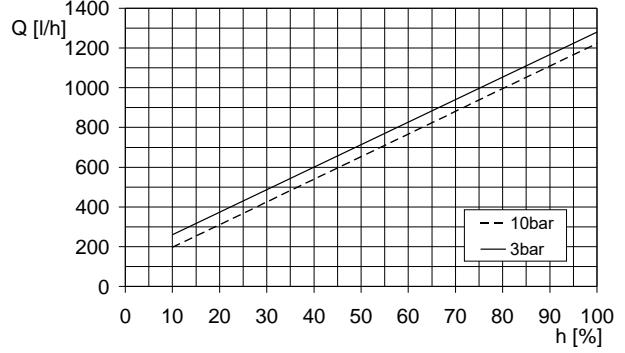

DMH 770-10 (60Hz) $Q_0 = 3\text{bar}$

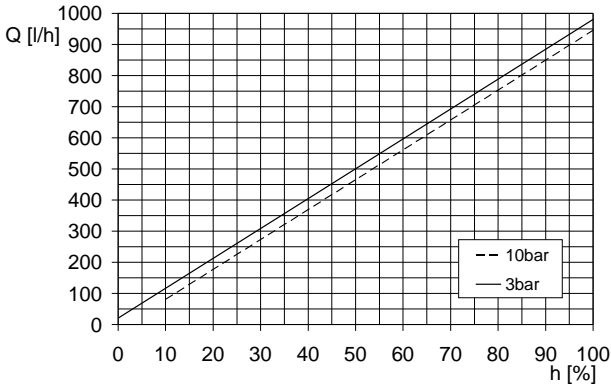

DMH 1500-4 (50Hz) $Q_0 = 3\text{bar}$

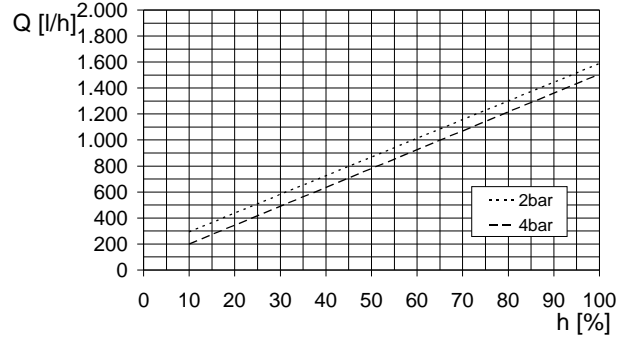

B.1. Safety declaration

- Please copy, fill in and sign this sheet and attach it to the product returned for service.
- Fill in this document using English or German language.

Fault description

- Please make a circle around the damaged part.
- In the case of an electrical or functional fault, please mark the cabinet.
- Please give a short description of the fault and indicate if the diaphragm is damaged:



TM074679

Declaration

We hereby declare that this product is free from hazardous chemicals, biological and radioactive substances:

Type designation (see nameplate):
Product number:

The product was used with the following dosing medium:

No dosing medium or water:
A chemical solution, name:

Date and signature:

Company stamp:

Argentina

Bombas GRUNDFOS de Argentina S.A.
Ruta Panamericana km. 37.500 Industiun
1619 - Garin Pcia. de B.A.
Tel.: +54-3327 414 444
Fax: +54-3327 45 3190

Australia

GRUNDFOS Pumps Pty. Ltd.
P.O. Box 2040
Regency Park
South Australia 5942
Tel.: +61-8-8461-4611
Fax: +61-8-8340-0155

Austria

GRUNDFOS Pumpen Vertrieb Ges.m.b.H.
Grundfosstraße 2
A-5082 Grödig/Salzburg
Tel.: +43-6246-883-0
Fax: +43-6246-883-30

Belgium

N.V. GRUNDFOS Bellux S.A.
Boomsesteenweg 81-83
B-2630 Aartselaar
Tel.: +32-3-870 7300
Fax: +32-3-870 7301

Belarus

Представительство ГРУНДФОС в Минске
220125, Минск
ул. Шафарьянская, 11, оф. 56, БЦ «Порт»
Tel.: +375 17 397 397 3
+375 17 397 397 4
Факс: +375 17 397 397 1
E-mail: minsk@grundfos.com

Bosnia and Herzegovina

GRUNDFOS Sarajevo
Zmaj od Bosne 7-7A
BiH-71000 Sarajevo
Tel.: +387 33 592 480
Fax: +387 33 590 465
www.ba.grundfos.com
E-mail: grundfos@bih.net.ba

Brazil

BOMBAS GRUNDFOS DO BRASIL
Av. Humberto de Alencar Castelo Branco,
630
CEP 09850 - 300
São Bernardo do Campo - SP
Tel.: +55-11 4393 5533
Fax: +55-11 4343 5015

Bulgaria

Grundfos Bulgaria EOOD
Slatina District
Iztochna Tangenta street no. 100
BG - 1592 Sofia
Tel.: +359 2 49 22 200
Fax: +359 2 49 22 201
E-mail: bulgaria@grundfos.bg

Canada

GRUNDFOS Canada inc.
2941 Brighton Road
Oakville, Ontario
L6H 6C9
Tel.: +1-905 829 9533
Fax: +1-905 829 9512

China

GRUNDFOS Pumps (Shanghai) Co. Ltd.
10F The Hub, No. 33 Suhong Road
Minhang District
Shanghai 201106 PRC
Tel.: +86 21 612 252 22
Fax: +86 21 612 253 33

Columbia

GRUNDFOS Colombia S.A.S.
Km 1.5 vía Siberia-Cota Conj. Potrero
Chico,
Parque Empresarial Arcos de Cota Bod. 1A.
Cota, Cundinamarca
Tel.: +57(1)-2913444
Fax: +57(1)-8764586

Croatia

GRUNDFOS CROATIA d.o.o.
Buzinski prilaz 38, Buzin
HR-10010 Zagreb
Tel.: +385 1 6595 400
Fax: +385 1 6595 499
www.hr.grundfos.com

Czech Republic

GRUNDFOS Sales Czechia and Slovakia
s.r.o.
Čajkovského 21
779 00 Olomouc
Tel.: +420-585-716 111

Denmark

GRUNDFOS DK A/S
Martin Bachs Vej 3
DK-8850 Bjerringbro
Tel.: +45-87 50 50 50
Fax: +45-87 50 51 51
E-mail: info_GDK@grundfos.com
www.grundfos.com/DK

Estonia

GRUNDFOS Pumps Eesti OÜ
Peterburi tee 92G
11415 Tallinn
Tel.: + 372 606 1690
Fax: + 372 606 1691

Finland

OY GRUNDFOS Pumput AB
Trukkikuja 1
FI-01360 Vantaa
Tel.: +358-(0) 207 889 500

France

Pompes GRUNDFOS Distribution S.A.
Parc d'Activités de Chesnes
57, rue de Malacombe
F-38290 St. Quentin Fallavier (Lyon)
Tel.: +33-4 74 82 15 15
Fax: +33-4 74 94 10 51

Germany

GRUNDFOS GMBH
Schlüterstr. 33
40699 Erkrath
Tel.: +49-(0) 211 929 69-0
Fax: +49-(0) 211 929 69-3799
E-mail: infoservice@grundfos.de
Service in Deutschland:
kundendienst@grundfos.de

Greece

GRUNDFOS Hellas A.E.B.E.
20th km. Athinon-Markopoulou Av.
P.O. Box 71
GR-19002 Peania
Tel.: +0030-210-66 83 400
Fax: +0030-210-66 46 273

Hong Kong

GRUNDFOS Pumps (Hong Kong) Ltd.
Unit 1, Ground floor, Siu Wai industrial
Centre
29-33 Wing Hong Street & 68 King Lam
Street, Cheung Sha Wan
Kowloon
Tel.: +852-27861706 / 27861741
Fax: +852-27858664

Hungary

GRUNDFOS Hungária Kft.
Tópark u. 8
H-2045 Törökbálint
Tel.: +36-23 511 110
Fax: +36-23 511 111

India

GRUNDFOS Pumps india Private Limited
118 Old Mahabalipuram Road
Thoraiakkam
Chennai 600 097
Tel.: +91-44 2496 6800

Indonesia

PT GRUNDFOS Pompa
Graha intirub Lt. 2 & 3
Jin. Ciliitan Besar No.454. Makasar,
Jakarta Timur
ID-Jakarta 13650
Tel.: +62 21-469-51900
Fax: +62 21-460 6910 / 460 6901

Ireland

GRUNDFOS (Ireland) Ltd.
Unit A, Merrywell Business Park
Ballymount Road Lower
Dublin 12
Tel.: +353-1-4089 800
Fax: +353-1-4089 830

Italy

GRUNDFOS Pompe Italia S.r.l.
Via Gran Sasso 4
I-20060 Truccazzano (Milano)
Tel.: +39-02-95838112
Fax: +39-02-95309290 / 95838461

Japan

GRUNDFOS Pumps K.K.
1-2-3, Shin-Miyakoda, Kita-ku
Hamamatsu
431-2103 Japan
Tel.: +81 53 428 4760
Fax: +81 53 428 5005

Korea

GRUNDFOS Pumps Korea Ltd.
6th Floor, Aju Building 679-5
Yeoksam-dong, Kangnam-ku, 135-916
Seoul, Korea
Tel.: +82-2-5317 600
Fax: +82-2-5633 725

Latvia

SIA GRUNDFOS Pumps Latvia
Deglava biznesa centrs
Augusta Deglava ielā 60
LV-1035, Rīga,
Tel.: + 371 714 9640, 7 149 641
Fax: + 371 914 9646

Lithuania

GRUNDFOS Pumps UAB
Smolensko g. 6
LT-03201 Vilnius
Tel.: + 370 52 395 430
Fax: + 370 52 395 431

Malaysia

GRUNDFOS Pumps Sdn. Bhd.
7 Jalan Peguam U1/25
Glenmarie industrial Park
40150 Shah Alam, Selangor
Tel.: +60-3-5569 2922
Fax: +60-3-5569 2866

Mexico

Bombas GRUNDFOS de México
S.A. de C.V.
Boulevard TLC No. 15
Parque industrial Stiva Aeropuerto
Apodaca, N.L. 66600
Tel.: +52-81-8144 4000
Fax: +52-81-8144 4010

Netherlands

GRUNDFOS Netherlands
Veluwezoom 35
1326 AE Almere
Postbus 22015
1302 CA ALMERE
Tel.: +31-88-478 6336
Fax: +31-88-478 6332
E-mail: info_gnl@grundfos.com

New Zealand

GRUNDFOS Pumps NZ Ltd.
17 Beatrice Tinsley Crescent
North Harbour Industrial Estate
Albany, Auckland
Tel.: +64-9-415 3240
Fax: +64-9-415 3250

Norway

GRUNDFOS Pumper A/S
Stramsveien 344
Postboks 235, Leirdal
N-1011 Oslo
Tel.: +47-22 90 47 00
Fax: +47-22 32 21 50

Poland

GRUNDFOS Pompy Sp. z o.o.
ul. Klonowa 23
Baranowo k. Poznania
PL-62-081 Przemierowo
Tel.: (+48-61) 650 13 00
Fax: (+48-61) 650 13 50

Portugal

Bombas GRUNDFOS Portugal, S.A.
Rua Calvet de Magalhães, 241
Apartado 1079
P-2770-153 Paço de Arcos
Tel.: +351-21-440 76 00
Fax: +351-21-440 76 90

Romania

GRUNDFOS Pompe România SRL
S-PARK BUSINESS CENTER, Clădirea
A2, etaj 2
Str. Tipografilor, Nr. 11-15, Sector 1, Cod
013714
Bucuresti, Romania
Tel.: 004 021 2004 100
E-mail: romania@grundfos.ro

Russia

ООО Грундфос Россия
ул. Школьная, 39-41
Москва, RU-109544, Russia
Тел. (+7) 495 564-88-00 (495) 737-30-00
Факс (+7) 495 564 8811
E-mail grundfos.moscow@grundfos.com

Serbia

Grundfos Srbija d.o.o.
Omladinskih brigada 90b
11070 Novi Beograd
Tel.: +381 11 2258 740
Fax: +381 11 2281 769
www.rs.grundfos.com

Singapore

GRUNDFOS (Singapore) Pte. Ltd.
25 Jalan Tukang
Singapore 619264
Tel.: +65-6681 9688
Fax: +65-6681 9689

Slovakia

GRUNDFOS s.r.o.
Prievozská 4D 821 09 BRATISLAVA
Tel.: +421 2 5020 1426
sk.grundfos.com

Slovenia

GRUNDFOS LJUBLJANA, d.o.o.
Leskoškova 9e, 1122 Ljubljana
Tel.: +386 (0) 1 568 06 10
Fax: +386 (0) 1 568 06 19
E-mail: tehnika-si@grundfos.com

South Africa

GRUNDFOS (PTY) LTD
16 Lascelles Drive, Meadowbrook Estate
1609 Germiston, Johannesburg
Tel.: (+27) 10 248 6000
Fax: (+27) 10 248 6002
E-mail: lgradidge@grundfos.com

Spain

Bombas GRUNDFOS España S.A.
Camino de la Fuentequilla, s/n
E-28110 Algete (Madrid)
Tel.: +34-91-848 8800
Fax: +34-91-628 0465

Sweden

GRUNDFOS AB
Box 333 (Lunnagårdsgatan 6)
431 24 Mölndal
Tel.: +46 31 332 23 000
Fax: +46 31 331 94 60

Switzerland

GRUNDFOS Pumpen AG
Bruggacherstrasse 10
CH-8117 Fällanden/ZH
Tel.: +41-44-806 8111
Fax: +41-44-806 8115

Taiwan

GRUNDFOS Pumps (Taiwan) Ltd.
7 Floor, 219 Min-Chuan Road
Taichung, Taiwan, R.O.C.
Tel.: +886-4-2305 0868
Fax: +886-4-2305 0878

Thailand

GRUNDFOS (Thailand) Ltd.
92 Chaloom Phrakiat Rama 9 Road
Dokmai, Pravej, Bangkok 10250
Tel.: +66-2-725 8999
Fax: +66-2-725 8998

Turkey

GRUNDFOS POMPA San. ve Tic. Ltd. Sti.
Gebze Organize Sanayi Bölgesi
Ihsan dede Caddesi
2. yol 200. Sokak No. 204
41490 Gebze/ Kocaeli
Tel.: +90 - 262-679 7979
Fax: +90 - 262-679 7905
E-mail: satis@grundfos.com

Ukraine

ТОВ "ГРУНДФОС УКРАЇНА"
Бізнес Центр Європа
Столицне шосе, 103
м. Київ, 03131, Україна
Tel.: (+38 044) 237 04 00
Fax: (+38 044) 237 04 01
E-mail: ukraine@grundfos.com

United Arab Emirates

GRUNDFOS Gulf Distribution
P.O. Box 16768
Jebel Ali Free Zone, Dubai
Tel.: +971 4 8815 166
Fax: +971 4 8815 136

United Kingdom

GRUNDFOS Pumps Ltd.
Grovebury Road
Leighton Buzzard/Beds. LU7 4TL
Tel.: +44-1525-850000
Fax: +44-1525-850011

U.S.A.

Global Headquarters for WU
856 Koomey Road
Brookshire, Texas 77423 USA
Phone: +1-630-236-5500

Uzbekistan

Grundfos Tashkent, Uzbekistan
The Representative Office of Grundfos
Kazakhstan in Uzbekistan
38a, Oybek street, Tashkent
Tel.: (+998) 71 150 3290 / 71 150 3291
Fax: (+998) 71 150 3292

99558949 05.2022
ECM: 1321884

Trademarks displayed in this material, including but not limited to Grundfos and the Grundfos logo, are registered trademarks owned by The Grundfos Group. © 2022 Grundfos Holding A/S, all rights reserved.