

CRUX

Sous Vide Professional Style Cooker Instruction Manual

Styled for Life
Designed & Engineered in New York City

Thank You for choosing
CRUX

We hope your new CRUX
small kitchen appliance will add
sleek elegance to your kitchen



Table of Contents



Important Safeguards.....	2-4
Additional Important Safeguards	5-6
Grounded 3-Conductor Plug	6
Notes on the Cord	7
Plasticizer Warning.....	7
Electric Power.....	7
Life is Busy.....	8
Getting to Know Your CRUX Sous Vide Professional Style Cooker	9
LED Display with Touchscreen Digital Controls.....	10
Start Up Guide with Temperature and Time Chart	11-16
Before Using for the First Time	17
Sous Vide Assembly	18
Operating Instructions.....	18-20
Auto Shut-Off	20
Hints & Tips for Sous Vide Cooking.....	20-21
USDA Cooking Guidelines.....	21
User Maintenance Instructions.....	21
Care & Cleaning Instructions	22
Descaling	22
Storing Instructions.....	22
Troubleshooting.....	23
Recipe Guide	24-33
Warranty	34-35





IMPORTANT SAFEGUARDS

WARNING: When using electrical appliances, basic safety precautions should always be followed, including the following:

1. **READ ALL INSTRUCTIONS.**
 2. **CAUTION:** The heating elements and removable stainless steel sleeve get hot during and after use. Do not touch any metal surface. The cooking container, water bath, and food pouches get hot during use. Use oven mitts or tongs when handling. Allow the Sous Vide Cooker to cool before emptying the water bath.
 3. To protect against electrical shock do not immerse cord or plugs in water or other liquid.
 4. This appliance is not intended for use by persons (including children) with reduced physical, sensory or mental capabilities, or lack of experience and knowledge, unless they have been given supervision or instruction concerning use of the appliance by a person responsible for their safety.
 5. Close supervision is necessary when any appliance is used by or near children.
 6. Unplug from outlet when not in use and before cleaning. Allow to cool before putting on or taking off parts.
 7. Do not operate any appliance with a damaged cord or plug or after the appliance malfunctions, or has been damaged in any manner. Bring it to a qualified technician for examination, repair or for electrical or mechanical adjustment.
- 
- 

- 
- 
- 
8. The use of accessory attachments not recommended by the appliance manufacturer may cause injuries.
 9. Do not use outdoors.
 10. Do not let cord hang over edge of table or counter, or touch hot surfaces.
 11. Do not place on or near a hot gas or electric burner, or in a heated oven.
 12. To disconnect, press and hold the ON/OFF (⏻) button for 3 seconds. Then remove plug from wall outlet.
 13. The Sous Vide Cooker is used to cook food only. Do not use appliance for other than intended use.
 14. This Sous Vide Cooker is not intended to be operated by means of an external timer or separate remote control system
 15. Never immerse the Sous Vide Cooker beyond the MAX water level mark. DO NOT immerse the LED display or handle. If the Sous Vide Cooker or any of these areas is submerged, immediately unplug the unit and contact customer service for assistance.
 16. Food should be sealed in quality, heavy-duty zippered bags, special sous vide bags or canning jars before cooking in the hot water bath.
 17. Time and temperature are critical in the cooking process because some bacteria can grow in food in the absence of oxygen and produce toxins. If food will not be consumed within 4 hours after sous vide cooking, cook until the food is pasteurized, or freeze for later use.

- 
- 
- 
18. Extreme caution must be used when moving an appliance containing hot oil or other hot liquids.
 19. Never operate the Sous Vide Cooker without the stainless steel sleeve securely locked over the heating elements.
 20. Never operate the CRUX Sous Vide Professional Style Cooker unless it is securely clipped to a sturdy vessel, such as a stock pot, at least 6.5 inches deep.
 21. This Sous Vide Cooker is designed to be used to heat water only.
 22. This CRUX Sous Vide Professional Style Cooker is equipped with an AUTO SHUT-OFF Safety Device. Intelligent water-level sensors will immediately turn the heating elements OFF if the unit is removed from the water or if the water falls below the MIN water level. An alarm will sound 3 times and Er1 will flash on the display until water is added or the unit is unplugged.

FOR HOUSEHOLD USE ONLY

SAVE THESE INSTRUCTIONS

ADDITIONAL IMPORTANT SAFEGUARDS

CAUTION HOT SURFACES: This appliance generates heat and escaping steam during use. Proper precautions must be taken to prevent the risk of burns, fires or other injury to persons or damage to property.

1. A person who has not read and understood all operating and safety instructions is not qualified to operate this appliance. All users of this appliance must read and understand this instruction manual before operating or cleaning this appliance.
2. If this appliance falls or accidentally becomes immersed in water, unplug it from the wall outlet immediately. **Do not reach into the water!**
3. When using this appliance, provide adequate air space above and on all sides for air circulation. Do not operate this appliance while it is touching or near curtains, wall coverings, clothing, dishtowels or other flammable materials.
4. Do not leave this appliance unattended during use.
5. If this appliance begins to malfunction during use, immediately unplug the cord. Do not use or attempt to repair a malfunctioning appliance!
6. The cord to this appliance should be plugged into a 120V AC 3-prong electrical wall outlet.
7. Do not use this appliance in an unstable position. The working area must be flat and level.

- 
8. Be careful when lifting the Sous Vide Cooker out of the hot water bath after cooking. Always lift the unit away from you as both the water bath and the unit are hot and can result in serious burns. Never place your face over the hot water bath or the unit.
 9. Unplug the unit when not in use and before cleaning. Allow the Sous Vide Cooker to cool before putting on or taking off parts to clean.
 10. The Sous Vide Cooker should NEVER contact food directly. Food products should NEVER come in contact with water bath. Food must be vacuum-sealed, heat sealed, or zip locked before use with the Sous Vide Cooker. Liquid food products like juice, soup or milk products need to be bagged or sealed in jars for sous vide cooking.

GROUNDING 3-CONDUCTOR PLUG



This appliance is equipped with a grounded-type 3-wire cord (3-prong plug). This plug will only fit into an electrical outlet made for a 3-prong plug. This is a safety feature. If the plug should fail to fit the outlet, contact an electrician to replace the obsolete outlet. Do not attempt to defeat this safety feature.



NOTES ON THE CORD

- a) A short power-supply cord (or detachable power-supply cord) is to be provided to reduce risks resulting from becoming entangled in or tripping over a longer cord.
- b) Longer detachable power-supply cords or extension cords are available and may be used if care is exercised in their use.
- c) If a long detachable power-supply cord or extension cord is used:
 - 1) The marked electrical rating of the detachable power-supply cord or extension cord should be at least as great as the electrical rating of the appliance;
 - 2) If the appliance is of the grounded type, the extension cord should be a grounding- type 3-wire cord; and
 - 3) The longer cord should be arranged so that it will not drape over the counter top or table top where it can be pulled on by children or tripped over.

PLASTICIZER WARNING

CAUTION: To prevent Plasticizers from migrating from the finish of the counter top or table top or other furniture, place NON-PLASTIC coasters or place mats between the appliance and the finish of the counter top or table top. Failure to do so may cause the finish to darken; permanent blemishes may occur or stains can appear.

ELECTRIC POWER

If the electrical circuit is overloaded with other appliances, your appliance may not operate properly. It should be operated on a separate electrical circuit from other appliances.

Life is Busy

Keep it simple in the kitchen with CRUX. Committed to efficiency, ease of use, and sleek design, our entire line of appliances was developed to make your life simpler. High quality products that get the job done, all while looking great on your countertop. It's never been easier to cook, host, or take on culinary adventures.

If you don't allow mediocrity in daily life, why would you settle for it in the kitchen? Precision Cooking is a classic cooking technique often used in professional kitchens that is now available at home. It delivers perfectly prepared food.

The CRUX Sous Vide operates with a 1000-watt heating capacity for lengthy cooking periods while the smart sensors turn the unit off when low level of water is detected.

Clip the CRUX Sous Vide Professional Style Cooker to the side of any pot holding 5-20 quarts of water. A unique, brushless motor silently circulates and maintains uniform heat with incredible accuracy. This water bath process cooks your favorite foods from steak, seafood even eggs. **Strive for restaurant style perfection—nothing less.**

Getting To Know Your CRUX Sous Vide Professional Style Cooker

Product may vary slightly from illustration

1. LED Display with Touchscreen Digital Controls
2. Handle with Power Cord and 3-Prong Plug
3. Heating Elements
4. Permanent Stainless Steel Sleeve with Pump Cover
5. MIN Water Level
6. MAX Water Level
7. Water Circulation Ducts
8. Adjustable Mounting Clip

Figure 1

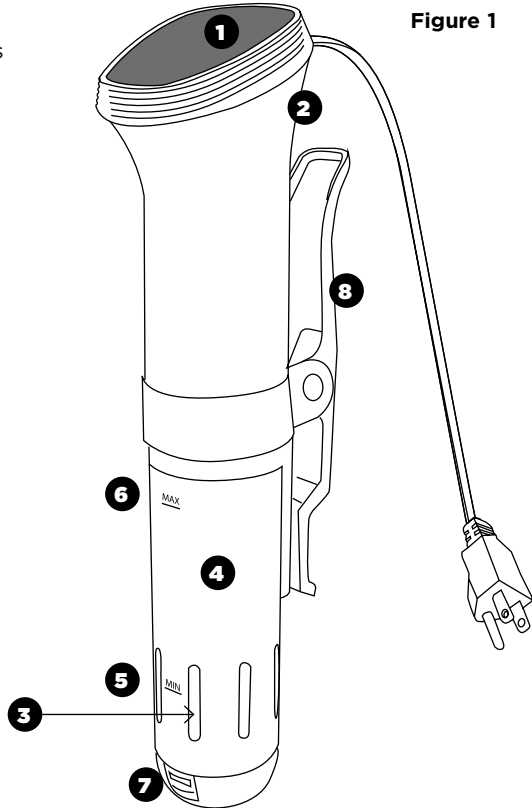

9

LED Display with Touchscreen Digital Controls

1. CURRENT WATER TEMPERATURE DISPLAY (°F/°C). Backlighted digital TEMPERATURE displays water temperature.
2. TEMPERATURE ICON (°F) illuminates when the target water TEMPERATURE (°F/°C) is on display.
3. BACKLIT DIGITAL TEMPERATURE DISPLAY. Default target water TEMPERATURE flashes until re-programmed. While in operation, the current/target TEMPERATURE will be displayed prominently on the top of the screen.
4. TIME ICON (⌚) illuminates when the target cook TIME is on display.
5. BACKLIT DIGITAL TIME DISPLAY. Default target TIME flashes until re-programmed. While in operation, remaining TIME will be displayed as it counts down to 00:00.
6. ON/OFF (⏻) Button. A lone red ON/OFF (⏻) button will appear on the display when the unit is plugged in. Press the ON/OFF button to turn the unit ON. Press the ON/OFF button again to confirm settings and to begin operation. While in operation, press and hold the ON/OFF button for 3 seconds to turn the unit OFF.
7. TIME/TEMPERATURE (⌚/°) Button. Press to re-program TIME or TEMPERATURE. Press and hold the TIME/TEMPERATURE (⌚/°) Button to change from (°F) to (°C). The hrs. or °F/°C will flash on the display until re-programmed or the ON/OFF (⏻) button is pressed.
8. (+) or (-) Buttons. Use the (+) or (-) buttons to adjust the cook TIME from 0:00 minutes to 99:59 hours in 1 minute increments; or press and hold any button to fast advance or reverse. Use the (+) or (-) buttons to adjust the cook TEMPERATURE from 32°F to 194°F; press and hold any button to fast advance or reverse.

Figure 2





Start Up Guide

THE ART OF SOUS VIDE COOKING:

This method of cooking achieves perfectly cooked meals every time with no risk of over or under cooking. Gourmet chefs have used this technique to prepare everything from meat, to eggs and even fruits and vegetables for over a century. The sous vide cooking method retains all of the food's nutrients and juices making it healthier and tastier than traditional cooking methods. Now from the comfort of your own home, you too can cook like a professional chef, all that is needed is a CRUX Sous Vide Professional Style Cooker, a resealable plastic bag and a pot of water.

PREPPING YOUR FOOD:

Place food into a BPA-free resealable plastic bags. Add spices or condiments into the bag if desired (see Temperature and Time Chart for some suggestions). When using spices and condiments a little bit goes a long way, experiment to find out your favorite seasonings and flavor intensities. You can also add a small amount of butter or oil to enhance flavor. It is important to remove as much air as possible from the bag **see page 21** for info on manual air removal.









FINISHING TOUCHES:

Many chefs like to give meat a quick sear to add grill marks and a crisp outer texture. Heat a small amount of butter or oil in a hot skillet and sear for 30 seconds on each side. For more Hints & Tips **see page 22**.



Sous Vide Temperature and Time Chart

BEEF









		MIN		MAX
Steak	RARE 129°F / 54°C	45min	 1.5hrs	3hrs
	MEDIUM RARE 136°F / 58°C	45min	 1.5hrs	3hrs
	WELL DONE 158°F / 70°C	45min	 1.5hrs	3hrs
Roast	RARE 133°F / 56°C	5.5hrs	 7hrs	16hrs
	MEDIUM RARE 140°F / 60°C	5.5hrs	 6hrs	14hrs
	WELL DONE 158°F / 70°C	 5hrs		11hrs
Tough Cuts	RARE 136°F / 58°C	 24hrs		48hrs
	MEDIUM RARE 149°F / 65°C	 16hrs		24hrs
	WELL DONE 185°F / 85°C	6.5hrs	 8hrs	16hrs

Seasoning Suggestions: Crushed Garlic, Thyme, Shallots



Sous Vide Temperature and Time Chart

PORK





		MIN		MAX
Chop	RARE 136°F / 58°C		1hr	2.5hrs
	MEDIUM RARE 144°F / 62°C		1hr	1.75hrs
	WELL DONE 158°F / 70°C		1hr	1.5hrs
Roast	RARE 136°F / 58°C	2.5hrs		5.5hrs
	MEDIUM RARE 144°F / 62°C	2.5hrs		4hrs
	WELL DONE 158°F / 70°C	2.5hrs		3.5hrs
Tough Cuts	RARE 144°F / 62°C	10hrs		24hrs
	MEDIUM RARE 154°F / 68°C	7hrs		24hrs
	WELL DONE 185°F / 85°C	6.5hrs		16hrs

Seasoning Suggestions: Rosemary, Maple Syrup, Whole Grain Mustard



Sous Vide Temperature and Time Chart

CHICKEN

	MIN		MAX
Light Meat SUPER-SUPPLE 140°F / 60°C	50min	 2hrs	3.5hrs
TENDER AND JUICY 149°F / 65°C	50min	 1hr	2hrs
WELL DONE 167°F / 75°C	50min	 1hr	1.5hrs
<hr/>			
Dark Meat TENDER 149°F / 65°C	50min	 1.5hrs	4.5hrs
FALLING OFF THE BONE 167°F / 75°C	50min	 1.5hrs	3hrs

Seasoning Suggestions: Oregano, Garlic, Paprika



Sous Vide Temperature and Time Chart

FISH

Tender 104°F / 40°C



Tender and Flaky 122°F / 50°C



Well Done 140°F / 60°C



Seasoning Suggestions: Lemon Slices, Dill, Lemon Thyme

EGGS

Soft Boiled 158°F / 70°C



Hard Boiled 170°F / 76°C

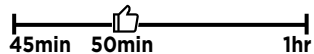

Poached 158°F / 70°C

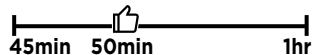



Sous Vide Temperature and Time Chart

VEGETABLES

	MIN	MAX
Green Vegetables 185°F / 85°C	10min	20mins
Winter Squash 185°F / 85°C	1hr	3hrs
Potatoes & Root Vegetables 185°F / 85°C	1hr	3hrs

Seasoning Suggestions: Rosemary, Basil, Chives

FRUIT

	MIN	MAX
Warm & Ripe 154°F / 68°C	1hr	2.5hrs
Cooked to Soft (for purées, etc.) 185°F / 85°C	15min	1.5hrs

Seasoning Suggestions: Cinnamon, Cloves, Nutmeg or Mint

Before Using for the First Time

1. Carefully unpack your CRUX Sous Vide Professional Style Cooker and discard all packaging materials. Your CRUX Sous Vide Professional Style Cooker comes assembled and ready for use.

2. SOUS VIDE PREPARATION:

You will need:

Figure 3

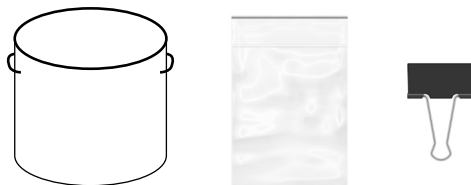

- A 5 to 20-quart pot or suitable container at least 6.5 inches deep.
- High quality, BPA-free **HEAVY-DUTY ZIPPERED PLASTIC BAGS**, preferably gallon-sized, accommodate several servings of food. Perfect for: steak, fish, pork chops, chicken breasts, hamburgers.
- **Special BPA-Free SOUS VIDE BAGS** have strong seams that are specifically designed for higher temperatures. Special sous vide bags are necessary when braising meats for long periods of time or cooking vegetables such as lentils or beans at temperatures above 160°.
- **SOUS VIDE BAGS** are vacuum sealable, but **can be used by manually displacing water, then folding and clipping the bag opening** over the side of the pot.
- **For longer sous vide cooking times**, add water to the MAX water level. Periodically check on water level and add water as needed.
- This CRUX Sous Vide Professional Style Cooker is equipped with an Auto Shut-Off safety device. Intelligent water-level sensors will immediately turn the heating elements OFF if the unit is removed from the water or if the water falls below the MIN water level.
- **CANNING JARS** should be used when cooking egg white bites, custards, curds, mousse, and yogurt.

Sous Vide Assembly

1. Place a 5 to 20 quart pot, at least 6.5 inches deep, on a flat, level heat-proof surface.
2. Insert the stainless steel sleeve into the container or pot. Position the mounting clip over the side of the pot so that the cord is faces away from water and towards the electrical outlet. (See Figure 4.) The unit should be stable against the side of the pot.
3. Add water to the pot. Make sure the water level is between the MIN. and MAX water level markings.

IMPORTANT: In the event the stainless steel sleeve is removed from the water or if the water falls below the MIN water level, intelligent water-level sensors will immediately turn the heating elements OFF. An alarm will sound 3 times and "Er1" will flash on the display until water is added or the unit is unplugged.

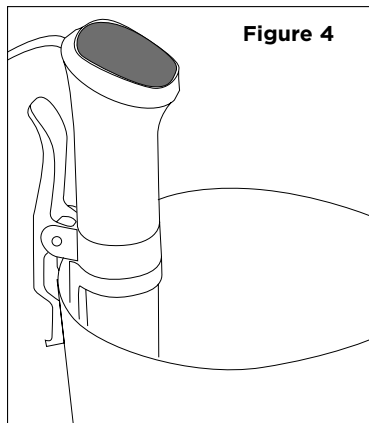

Operating Instructions

1. Plug cord into a 120V AC 3-prong electrical wall outlet. A lone red ON/OFF (⏻) button on a black control panel will appear.
2. Press and hold the ON/OFF (⏻) button for 3 seconds.
3. An audible beep can be heard as the current water TEMPERATURE (°F) is displayed prominently on the top of the screen. The default TEMPERATURE 120°F and the ON/OFF (⏻) button will begin to flash.
4. Press the (+) or (-) buttons to adjust the target cook TEMPERATURE from 32°F to 194°F. Press and hold the button to fast advance or reverse.
5. Press the TIME/TEMPERATURE (⌚) button. An audible beep can be heard as the default TIME (3:00) begins to flash. Use the (+) or (-) buttons to adjust the cook TIME from 0:00 minutes to 99:59 hours in 1 minute increments. Press and hold the button to fast advance or reverse.

- 
6. When the target TEMPERATURE and TIME have been programmed, press the ON/OFF (⏻) button. An audible beep will be heard. In a few seconds, the water will begin to circulate.
 7. While the water is preheating, prepare food. Add herbs, seasonings or rubs to all foods before placing into cooking bags. Vacuum seal or remove air manually from the bag before cooking.
 8. **Manual Air Removal.** The manual water displacement method works to remove air from plastic bags without the use of a vacuum sealer. This method is especially necessary when cooking softer foods such as hamburgers or chicken breasts, when the food product would lose its form using a vacuum sealer.
 9. Fill a large container with cool water. Prepare food to be cooked and place in a BPA-free plastic freezer bag. Do not seal.
 10. Slowly immerse the food-filled bag into the water. This will force the air out as the bag is immersed. Continue immersing the bag until just before the water reaches the top of the bag. While still in the water, close or zip to seal, forcing out all remaining air as much as possible.



IMPORTANT! Avoid overcrowding. Allow space around all food when sealing.

HINT! To prevent bags from floating to the surface, when cooking light foods, add a small knife or spoon to the bottom of the bag before sealing.

HINT! Eggs in shells can be placed directly into the pot of water. Use resealable bags for cracked eggs.



11. When the water temperature reaches the target TEMPERATURE, an audible beep will sound, the colon (:) will flash as TIME begins to count down.
12. Add cooking bags or jars to the heated water bath. For best results, bags must be fully immersed in the water bath. Use clips to attach the tops of the bags to the top of the cooking pot for support and to avoid leakage.
IMPORTANT: You can add many bags as will fit in your cooking pot as long as there is adequate water circulation around each cooking bag.
13. When the TIME counts down to 00:00, 2 audible beeps signal the CRUX Sous Vide Professional Style Cooker turning itself OFF. A lone red ON/OFF (⏻) will appear on the display.

- 
14. Using oven mitts or tongs, carefully remove the cooking bags. Open carefully. Allow a few seconds for all steam to escape. Test food to make sure it is fully cooked.
 15. Sear foods in a hot skillet or grill for a quick minute after sous vide cooking to achieve a crispy crust and brown color before serving.
 16. When cooking is completed unplug the CRUX Sous Vide Professional Style Cooker and allow to cool completely before cleaning.
 17. Using oven mitts or tongs, carefully remove the cooking bags. Open carefully. Allow a few seconds for all steam to escape. Test food with a meat thermometer to make sure it is fully cooked.
 18. Sear foods in a hot skillet or grill for a quick minute after sous vide cooking to achieve a crispy crust and brown color before serving.

CAUTION: Allow unit and water to cool before cleaning or storing.

Auto Shut-Off



This CRUX Sous Vide Professional Style Cooker is equipped with an Auto Shut-Off safety device. Intelligent water-level sensors will immediately turn the heating elements OFF if the unit is removed from the water or if the water falls below the MIN water level. An alarm will sound 3 times as “Er1” flashes on the display until water is added or the unit is unplugged.



Hints & Tips for Sous Vide Cooking

- To avoid water spots and calcification, and to ease cleaning stainless steel parts, prepare the water bath using soft/decalcified water.
- The thickness of meat, poultry and fish will determine the length of cooking time. Use an instant-read thermometer after removing from the cooking bag to guarantee that a safe-food temperature is achieved.
- Food safety in handling and cooking is always a priority. When unsure of doneness, add 30 minutes to the cook time to pasteurize eggs and/or poultry.
- Some tough cuts of beef and pork can be cooked sous vide to tender perfection in 4 to 24 hours.
- Vegetables cook faster if they are thinly sliced or cut into smaller pieces. Add cook time if vegetables are cooked whole.

- To prepare meat, poultry and fish before cooking, add herbs, seasonings or rubs before placing into the bag. Vacuum seal or remove air manually from the bag before cooking. Please see “Manual Air Removal” section of this instruction manual for a complete description.
- To prevent bags from floating to the surface, when cooking light foods, add a small knife or spoon to the bag before sealing.
- Eggs in shells can be placed directly into the pot of water. Use resealable bags for cracked eggs.
- **For best results**, brine chicken or fish for one hour in lightly salted water, drain and pat dry before seasoning and bagging.
- ALWAYS use BPA-free bags when cooking foods more than 8 hours.
- When cooking proteins, small or delicate foods sous vide, add oil to the cooking bag.
- **Avoid overcrowding. Allow space around all food when sealing.**
- You can have as many bags as will fit in your container that will still allow for adequate water circulation.
- After sous vide cooking is complete, sear foods for a quick minute to achieve a crispy crust and brown color.

USDA Cooking Guidelines

PLEASE NOTE: The USDA recommends that meats such as beef and lamb, etc. should be cooked to an internal temperature of 145°F/63°C. Pork should be cooked to an internal temperature of 160°F/71°C and poultry products should be cooked to an internal temperature of 170°F/77°C - 180°F/82°C to be sure any harmful bacteria has been killed. When reheating meat/poultry products, they should also be cooked to an internal temperature of 165°F/74°C.

User Maintenance Instructions

This appliance requires little maintenance. It contains no user serviceable parts. Do not try to repair it yourself. Any servicing requiring disassembly other than cleaning, must be performed by a qualified appliance repair technician.

Care & Cleaning Instructions

IMPORTANT! To avoid water spots and calcification, and to ease cleaning stainless steel parts, prepare the water bath using soft, decalcified water.

CAUTION: The heating elements and removable stainless steel sleeve get hot during and after use. Unplug unit and allow the CRUX Sous Vide Professional Style Cooker to cool. Remove unit from the stainless steel ring before emptying the water bath.

1. Always unplug and allow to cool completely before cleaning.
2. Wipe the handle with a soft, slightly damp cloth or sponge. Never use abrasive cleansers or scouring pads, as they may damage the surfaces.

Descaling

1. After several uses, descaling may be required, particularly if hard water is used in cooking. Assemble the CRUX Sous Vide Professional Style Cooker following the instructions described in “**Sous Vide Assembly**” section of this instruction manual.
2. Add one (1) ounce citric acid descaling powder (food grade) to the water.
3. Set the TEMPERATURE to 158°F and TIME for 20 minutes. When descaling is complete, press and hold the ON/OFF (●) button for 3 seconds to turn the unit OFF and unplug the unit.
4. When cool, rinse the area under the handle in clean, cool water. Wipe dry with a soft cloth.

Storing Instructions

1. Be sure all parts are clean and dry before storing. Never store the CRUX Sous Vide Professional Style Cooker while it is hot or wet.
2. Store CRUX Sous Vide Professional Style Cooker in its box or in a clean, dry place.
3. Do not put any stress on cord where it enters unit, as this could cause cord to fray and break.

Troubleshooting

Problem:	Cause:	Solution:
The ON/OFF button is flashing but the CRUX Sous Vide Professional Style Cooker has not turned ON.	The unit has not been activated.	Press and hold the ON/OFF (⏻) button for 3 seconds to activate.
The CRUX Sous Vide Professional Style Cooker alarm has sounded 3 times; the unit is OFF and Er1 is flashing on the LED display	<ul style="list-style-type: none"> • The water pot has not been filled. • The water level has fallen below the MINIMUM water level mark. • Electronics error. 	<ul style="list-style-type: none"> • Unplug the CRUX Sous Vide Professional Style Cooker. Add water past the MINIMUM water level mark. Plug into a 120V AC 3-prong electrical wall outlet. Press and hold the ON/OFF (⏻) button for 3 seconds to restart operation. • Contact Consumer Service
The CRUX Sous Vide Professional Style Cooker has turned itself OFF and Er1 appears in LED display.	<ul style="list-style-type: none"> • The water level has fallen below the MINIMUM water level mark. • The overheat protection has been triggered. • Electronics error. 	<ul style="list-style-type: none"> • Unplug the CRUX Sous Vide Professional Style Cooker. Add water past the MINIMUM water level mark. Plug into a 120V AC 3-prong electrical outlet. Press and hold the ON/OFF (⏻) button for 3 seconds to restart operation. • Contact Consumer Service.

Recipes

Classic Sirloin Steak with Thyme, Garlic & Cherry Tomatoes

Soft, moist, delicious, always cooked to perfection. This steak melts in your mouth.

Serves 2

- 2 (6 oz.) angus sirloin steaks
 - 1 tablespoon extra virgin olive oil
 - 1 tablespoon steak seasoning
 - 2 tablespoons chopped fresh thyme, plus 4 sprigs
 - 4 garlic cloves
 - 2 tablespoons butter, for searing
 - 4 cherry tomatoes
1. **Following the directions outlined in the instruction manual, assemble and program the CRUX Sous Vide Professional Style Cooker: 130°F for 1 hour/ Rare or 140°F for 1 hour/ Medium.**
 2. **Add 1 steak, 1/2 tablespoon olive oil, 1/2 tablespoon steak seasoning, 1 tablespoon fresh thyme + 2 sprigs, 2 garlic cloves and 2 tomatoes to each of 2 large zipper or vacuum seal bags. Toss thyme and steak seasoning into each bag. Massage seasonings into all sides of the steaks.**
 3. **Vacuum seal each steak individually, or remove as much air as possible from the zipper bag. When the ready signal sounds, place and clip both bags in the water, making sure each bag is fully submerged.**
 4. **When the TIME counts down to 00:00, at the 2 beep signal, using oven mitts or tongs, carefully remove each cooking bag. Remove steaks and garlic from bags and pat dry**
 5. **Sear steaks, garlic and fresh cherry tomatoes in a hot buttered cast iron skillet until brown. Allow each steak to rest 20 minutes before slicing.**

Recipes

Mushroom Mélange

Serve these savory mushrooms alongside Classic Sirloin Steak. Add to buttered noodles, brown rice, Israeli couscous, or polenta. Chop Mushroom Mélange to use as a base for mushroom aioli.

Serves 4

- 1 lb. sliced baby portobello, oyster, shitake, and/or morel mushrooms, your choice

Marinade

- 3 tablespoons olive oil
- 2 tablespoons soy sauce

- 2 tablespoons Worcestershire sauce
- 1 tablespoon chopped fresh thyme
- 6 cloves roasted garlic (may substitute 2 cloves raw garlic, minced)

1. Following the directions outlined in the instruction manual, assemble and program the CRUX Sous Vide Professional Style Cooker: 176°F for 30 minutes.
2. Add all ingredients to a large zipper bag. Massage marinade into the sliced mushrooms.
3. Remove as much air as possible from the bag. When the ready signal sounds, place and clip bag in water, making sure the bag is fully submerged.
4. When the TIME counts down to 00:00, at the 2 beep signal, using oven mitts or tongs, carefully remove the cooking bag. Drain the mushrooms, reserve the rich and flavorful cooking liquid for later use in soups, gravies, sauces.
5. Use a hot iron skillet to sear mushrooms in butter until the mélange is a buttery brown.

TIP: Wild Mushroom Tapas! Pile warm Wild Mushroom Mélange onto toasted crusty bread. Top with a thin slice of triple cream brie cheese. Place under a preheated broiler for 30 seconds to 1 minute or until the cheese is softened to your liking.

Recipes

Buttery Thyme Carrots

Serves: 4

- 1 lb. fresh thin organic carrots, tops intact
 - 2 tablespoons salted butter, room temperature
 - 2 tablespoons dried thyme (may substitute 4 tablespoons fresh thyme.)
- 1. Following the directions outlined in the instruction manual, assemble and program the CRUX Sous Vide Professional Style Cooker: 185°F for 1 hour.**
 - 2. Add all ingredients to a large zipper or vacuum seal bag. Massage butter and thyme into carrots.**
 - 3. Vacuum seal carrots or remove as much air as possible from the bag. When the ready signal sounds, place and clip bag in water, making sure the bag is fully submerged.**
 - 4. When the TIME counts down to 00:00, at the 2 beep signal, using oven mitts or tongs, carefully remove the cooking bag. Carrots are sweet, tender, and ready to serve.**

Recipes

Herb Buttered Corn on the Cob

Serves 2

- 2 ears fresh corn on the cob, husked and cleaned
 - 2 tablespoons salted butter, room temperature
 - 2 teaspoons adobo seasoning
 - 2 teaspoons ground cumin
 - 1 tablespoon fresh parsley (may substitute cilantro)
1. **Following the directions outlined in the instruction manual, assemble and program the CRUX Sous Vide Professional Style Cooker: 185°F for 1 hour.**
 2. **Slather the butter on all sides of the corn. Add to a large zipper or vacuum seal bag. Toss adobo seasoning and cumin into the bag. Massage seasonings into all sides of the buttered corn.**
 3. **Vacuum seal corn or remove as much air as possible from the bag. When the ready signal sounds, place and clip bag in water, making sure the bag is fully submerged.**
 4. **When the TIME counts down to 00:00, at the 2 beep signal, using oven mitts or tongs, carefully remove the cooking bag. Corn is sweet as candy and ready to eat.**

Bacon Wrapped Pork Tenderloin Tournedos

Tournedos are rings of pork cut from the loin. Each bite is encased in a ring of crispy, bacon. The smoky sweet flavor permeates each soft, tender pork bite.

Serves: 2 - 3

- 1 lb. pork tenderloin
- 6 strips thick cut bacon
- freshly ground black pepper
- 1 tablespoon Dijon mustard

See next page

Recipes

1. Following the directions outlined in the instruction manual, assemble and program the CRUX Sous Vide Professional Style Cooker: 135°F for 1 hour/ Medium Rare or 145°F for 1 hour/ Medium.
2. Spread a 13-inch x 13-inch piece of parchment paper out on a clean work surface.
3. Lay out 6 strips of bacon vertically (the width of the tenderloin) on the parchment.
4. Center the tenderloin horizontally on top of the bacon.
5. Brush mustard over all surfaces of the tenderloin. Season the pork tenderloin generously with black pepper.
6. Pick up the edge of parchment paper nearest to you. Pick the bacon up and lay it around the pork. Repeat to wrap the remaining bacon around the tenderloin. Set pork aside.

NOTE: It's fine if bacon overlaps.

7. Lay out 3 to 5 pieces of cooking twine vertically, an inch or so apart, on the work surface. Center the bacon-wrapped tenderloin horizontally on top of the string and tie to secure. Place into a large zipper or vacuum seal bag.
8. Vacuum seal bacon-wrapped pork or remove as much air as possible from the bag. When the ready signal sounds, place and clip bag in water, making sure the bag is fully submerged.
9. When the TIME counts down to 00:00, at the 2 beep signal, using oven mitts or tongs, carefully remove the cooking bag.
10. Use a hot iron skillet to sear bacon. Allow to rest 15 minutes; then cut into 1-inch thick Tournedos.
11. Serve with bacony potato salad, sautéed red cabbage with raisins and green beans.

Recipes

Cod Filets with Lemon & Cilantro

Never over-cook your fish again! Sous Vide preparation delivers a soft, buttery texture and delicate flavor.

Serves: 2

- 2 (6 oz.) cod filets
- 2 teaspoons Old Bay Seafood Seasoning
- 1 tablespoon extra virgin olive oil
- 1 lemon, thinly sliced
- 1 teaspoon freshly squeezed lime juice
- handful fresh cilantro
- 1 tablespoon salted butter

- 1. Following the directions outlined in the instruction manual, assemble and program the CRUX Sous Vide Professional Style Cooker: 132°F for 30 minutes.**
- 2. Add all ingredients to a large zipper or vacuum seal bag.**
- 3. Vacuum seal fish or remove as much air as possible from the zipper bag. When the ready signal sounds, place and clip bag in water, making sure the bag is fully submerged.**
- 4. When the TIME counts down to 00:00, at the 2 beep signal, using oven mitts or tongs, carefully remove the cooking bag.**
- 5. If a brown crusty exterior is desired, pat fish dry, and quickly sear fish in a hot skillet until browned.**

Recipes

Sous Vide Spicy Chili Chicken Wings

Serves 2 - 3

- 4 to 6 chicken wings, split into flats, drumettes, tips
- 1 (1-inch) piece fresh ginger, grated
- 6 green onions, chopped

Chili Sauce

- 2 tablespoons peanut oil
- 1 teaspoon toasted sesame oil
- 1 teaspoon hot chili oil
- 4 - 6 teaspoons Sriracha sauce
- 2 - 3 teaspoons honey, or more, to taste
- 1 - 1/2 tablespoons soy sauce
- 1 - 1/2 tablespoons Worcestershire sauce
- 3 jalapenos, cut into thin rings
- 1 red chili pepper, thinly sliced, seeds removed
- 2 - 3 tablespoons toasted sesame seeds for garnish

- 1. Following the directions outlined in the instruction manual, assemble and program the CRUX Sous Vide Professional Style Cooker: 167°F for 1 hour.**
- 2. Add wings, ginger and green onions to a large zipper or vacuum seal bag. Massage seasonings into all sides of the chicken wings.**
- 3. Vacuum seal wings or remove as much air as possible from the zipper bag. When the ready signal sounds, place and clip bag in water, making sure the bag is fully submerged.**
- 4. When the TIME counts down to 00:00, at the 2 beep signal, using oven mitts or tongs, carefully remove the cooking bag.**
- 5. Combine Chili Sauce ingredients in a small bowl. Open the top of the cooking bag and add the Sauce. Massage the wings in the bag with Chili Sauce. Spread sauced chicken wings onto a large sheet pan lined with parchment paper.**
- 6. Place chicken under a pre-heated broiler or in an Air Fryer for 7 to 12 minutes, turning halfway, until golden brown. Toss jalapeno rings and sesame seeds over finished chicken wings before serving.**

Recipes

Citrus Creme Brûlée

This elegant dessert has just become fool-proof and our make-ahead party favorite!. We used 2 (5-oz.) mason jars for perfect individual servings. Citrus Creme keeps covered in the refrigerator for up to 5 days! Add a generous sprinkle of sugar on top. Dazzle your guests as you bring out your blow torch for the crispy sugar crunch.

Serves 2

- 4 large egg yolks
- 1-1/4 cup heavy cream
- 1/4 cup granulated sugar
- salt, pinch
- 1 tablespoon lemon zest
- 1/4 teaspoon vanilla extract
- 1/4 teaspoon orange extract
- fresh berries, for garnish

1. **Add all ingredients, except fresh berries, into a medium mixing bowl. Whisk well until pale yellow in color. Strain to eliminate any foam. Pour into 2 (5 oz.) mason jars.**

IMPORTANT: Do not tighten lids completely to allow air to escape and prevent jars from cracking.

2. **Following the directions outlined in the instruction manual, assemble and program the CRUX Sous Vide Professional Style Cooker: 176°F for 1 hour.**
3. **When the ready signal sounds, place both filled jars into the bath.**
4. **When the TIME counts down to 00:00, at the 2 beep signal, using tongs, carefully remove each jar from the water and dry with a towel. Cool before refrigerating for a minimum of 4 hours.**

NOTE: Custard will keep covered in the refrigerator for up to 5 days.

5. **Before serving, sprinkle 1 teaspoon granulated sugar on the top of each custard. Caramelize sugar using a blow torch or place under a carefully-watched preheated broiler for 1 to 2 minutes.**
6. **Garnish with fresh berries.**

Recipes

Peppercorn Scallops over Angel Hair Pasta

Spicy, loaded with texture and flavor.

Serves 3 - 4

- 1 lb. (10 - 12) large sea or smaller bay scallops, side muscles removed
- 3 - 4 teaspoons mixed peppercorns, coarsely ground
- 6 garlic cloves, minced
- 1 teaspoon Old Bay Seafood Seasoning
- 1 tablespoon extra virgin olive oil
- 1 tablespoon unsalted butter, melted
- 1 lb. angel hair pasta, cooked al dente
- 1/2 cup reserved pasta water
- Parmesan cheese, freshly grated
- Salt, to taste
- black pepper, freshly ground
- scallop shells for serving

- 1. Following the directions outlined in the instruction manual, assemble and program the CRUX Sous Vide Professional Style Cooker: 123°F for 30 minutes.**
- 2. Add all ingredients to large bowl. Toss scallops in the butter, oil, and seasonings.**
- 3. Divide contents of bowl in half and place in 2 large zipper or vacuum seal bags.**
- 4. Vacuum seal both bags of scallops with space between each scallop; or align scallops in 1 row or 1 layer and remove as much air as possible from a zipper bag. When the ready signal sounds, place and clip bag in water, making sure the bag is fully submerged.**
- 5. When the TIME counts down to 00:00, at the 2 beep signal, using oven mitts or tongs, carefully remove the cooking bag.**
- 6. Pat scallops dry. Melt butter in a large skillet over high heat. Add the scallops and garlic. Quickly sear until golden brown on both sides. Add pasta to the skillet. If a creamier sauce is desired, add 1 tablespoon of pasta water at a time until the consistency is perfect.**
- 7. Transfer to a serving bowl. Arrange festively with scallop shells and serve over angel hair pasta. Top with freshly grated parmesan cheese, if desired.**

Recipes

It's a Beautiful Day Breakfast Toast

Poaching eggs is one of the most appreciated uses for the Sous Vide cooking method. Perfectly Poached Eggs may be easily cooled and stored. To serve, reheat in a 140°F bath for 1 minute.

- 2 large eggs, cold out of the refrigerator
- 8 fresh asparagus spears, trimmed
- 4 bacon strips, halved lengthwise
- 2 pieces rye, artisan, or any crusty bread of your choice
- cream cheese: plain, chive, or vegetable (may substitute goat cheese)
- black pepper, freshly ground
- salt
- paprika

- 1. Prepare bacon-wrapped asparagus. Preheat oven to 400°F.**
- 2. Wrap a strip of bacon around each asparagus spear; secure both ends with toothpicks. Dust with black pepper.**
- 3. Place on a slotted grill pan and bake for 12 minutes, or Air Fry at 400°F for 12 minutes until bacon is crispy, brown, and asparagus are tender. Check and turn several times.**
- 4. Prepare Perfectly Poached Eggs. Following the directions outlined in the instruction manual, assemble and program the CRUX Sous Vide Professional Style Cooker: 167°F for 13 minutes (for runny egg whites) or 14 minutes (for firmer, more congealed egg whites).**
- 5. When the ready signal sounds, carefully place eggs into the water, taking care not to break the shells.**
- 6. During the last minutes of cooking, toast the bread.**
- 7. When the TIME counts down to 00:00, at the 2 beep signal, using oven mitts or tongs, carefully remove the eggs.**
- 8. Assemble Breakfast Toasts. Smear cream cheese onto each piece of toast. Line up 4 bacon-wrapped asparagus on each; then top with a Perfectly Poached Egg. Season with salt, freshly ground black pepper, and a sprinkle of paprika.**

Limited Two-Year Warranty

SENSIO Inc. hereby warrants that for a period of **TWO YEARS** from the date of purchase, this product will be free from mechanical defects in material and workmanship, and for 90 days in respect to non-mechanical parts. At its sole discretion, SENSIO Inc. will either repair or replace the product found to be defective, or issue a refund on the product during the warranty period.

The warranty is only valid for the original retail purchaser from the date of initial retail purchase and is not transferable. Keep the original sales receipt, as proof of purchase is required to obtain warranty validation. Retail stores selling this product do not have the right to alter, modify, or in any way revise the terms and conditions of the warranty.

Exclusions:

The warranty does not cover normal wear of parts or damage resulting from any of the following: negligent use of the product, use of improper voltage or current, improper routine maintenance, use contrary to the operating instructions, disassembly, repair, or alteration by anyone other than qualified SENSIO Inc. personnel. Also, the warranty does not cover Acts of God such as fire, floods, hurricanes, or tornadoes.

SENSIO Inc. shall not be liable for any incidental or consequential damages caused by the breach of any express or implied warranty.

Apart from the extent prohibited by applicable law, any implied warranty of merchantability or fitness for a particular purpose is limited in time to the duration of the warranty. Some states, provinces or jurisdictions do not allow the exclusion or limitation of incidental or consequential damages, or limitations on how long an implied warranty lasts, and therefore, the above exclusions or limitations may not apply to you. The warranty covers specific legal rights which may vary by state, province and/or jurisdiction.

How To Obtain Warranty Service:

You must contact Customer Service at our toll-free number: 1-866-832-4843. A Customer Service Representative will attempt to resolve warranty issues over the phone. If the Customer Service Representative is unable to resolve the problem, you will be provided with a case number and asked to return the product to SENSIO Inc. Attach a tag to the product that includes: your name, address, daytime contact telephone number, case number, and description of the problem.

Also, include a copy of the original sales receipt. Carefully package the tagged product with the sales receipt, and send it (with shipping and insurance prepaid) to SENSIO Inc.'s address. SENSIO Inc. shall bear no responsibility or liability for the returned product while in transit to SENSIO Inc.'s Customer Service Center.





CRUX





For customer service questions or comments
1-866-832-4843

For Recipes and Cooking tips
cruxkitchen.com

 crux.kitchen  cruxkitchen  cruxkitchen  cruxkitchen  CRUX kitchen

CRUX is a trademark of 8479950 Canada Inc.,
Montreal, Canada H3B 3X9.
All rights reserved

SO-314962 R.1