



Submittal Data Information

101-070

Cartridge Style Pressure Reducing Valve

Effective: September 14, 2012

Supersedes: June 15, 2005

Job: _____ Engineer: _____ Contractor: _____ Rep: _____

ITEM NO.	MODEL NO.	

Features

- Automatic Pressure Reset from Fast Fill
- Easy External Dial-up Pressure Setting
- Set Pressure Indicator
- Simple serviceability with the unique one piece cartridge
- Internal check allows the cartridge to be replaced without draining the system
- Integral Strainer
- ASSE 1003

Product Specifications

- Max. Inlet Pressure..... 250 psi
- Adjustment Range..... 10 – 50 psi
- Max. Temp..... 210°F
- Factory Setting..... 12 psi
- Media..... Water

Materials of Construction

- BodyForged Brass
- Cartridge.....Wetted Parts
Stainless Steel,
Engineered Plastics,
Bronze, EPDM Seals

Purpose

The 3350 valve is used to automatically feed water to a hydronic system whenever pressure in the system drops below the pressure setting of the valve.

Operation

The cartridge style design ensures unsurpassed output pressure stability. A balance between diaphragm position and spring tension based on the desired outlet pressure is consistently maintained, even when inlet pressures fluctuate severely. The unique one-piece cartridge design significantly reduces diaphragm load, extending the overall product life. Unlike conventional PRV designs, the diaphragm does not double as a seal between the body and the cap. This allows for optimization of the

diaphragm for its intended use - maintaining pressure stability. A unique encapsulated shaft seal system prevents flowing media from contacting the diaphragm, greatly extending diaphragm life. If the diaphragm ever does fail, the encapsulated shaft and body seals work together to stop water from exiting the valve. Use of a stainless steel coaxial strainer prohibits system debris from affecting the valves' performance. An integral check valve allows the cartridge to be removed under system pressure for replacement or servicing.

Fast Fill

The 3350 provides an efficient and simple solution to filling your heating system. Simply push down the fast fill button on top of the PRV and when the set pressure is reached the valve pops out of fast fill and returns to its normal operating mode. This automatic reset feature of the fast fill on the 3350 eliminates the common problem of system over pressurization and prevents the relief valve from blowing off.

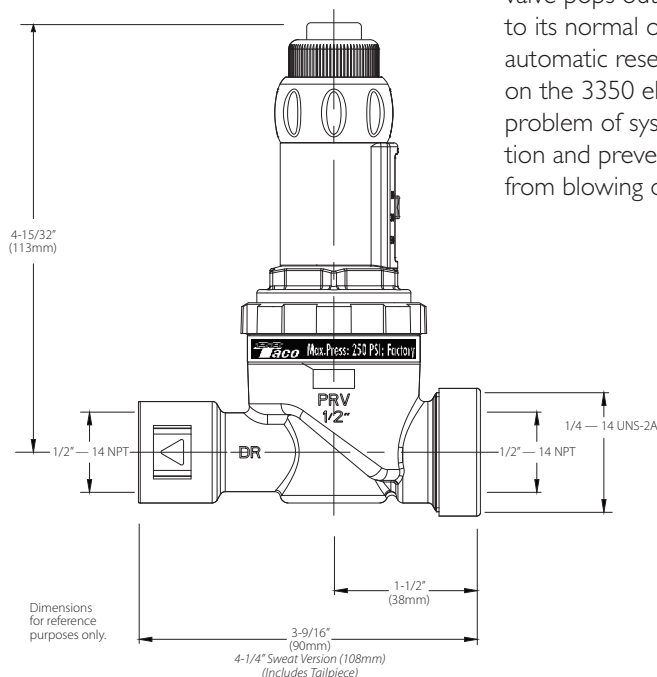

Do it Once. Do it Right.®

TACO INC., 1160 Cranston Street, Cranston, RI 02920 Telephone: (401) 942-8000 Fax: 942-2360
TACO (Canada), Ltd., 6180 Ordan Drive, Mississauga, Ontario L5T 2B3 Telephone: (905) 564-9422 Fax: (905) 564-9436
Visit our website at: www.taco-hvac.com

Printed in USA
Copyright 2012
TACO, Inc.