



Instruction Sheet

102-349

Outdoor Wood Boiler Series Hi-Capacity Circulator

SUPERSEDES: November 10, 2009

EFFECTIVE: May 1, 2010

Plant ID# 001-3914

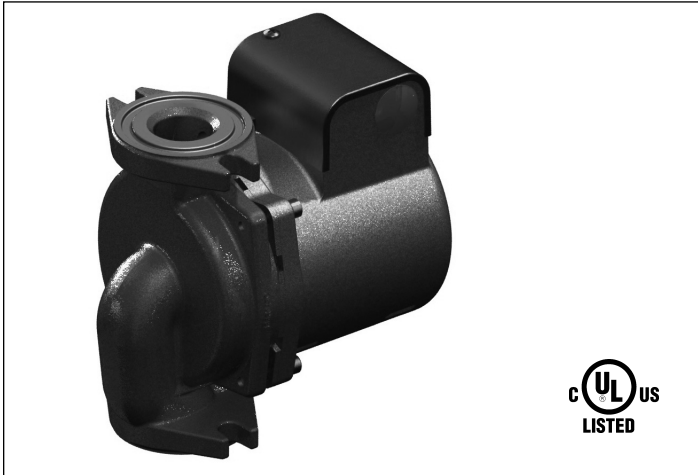

INSTALLER: Please leave these instructions for owner's use.

APPLICATION:

The Taco Wood Boiler Series Hi-Capacity circulators are designed specifically for use on unpressurized outdoor wood boiler applications. Features include a quiet running, close-coupled, thermally protected motor assembly with permanent split-capacitor and permanently lubricated bearings. A stainless steel shaft, silicon-carbide mechanical seal and non-ferrous impeller make the Wood Boiler Series Circulator an ideal choice for years of maintenance-free operation.

Note: Use Stainless Steel body circulators on open systems for the best corrosion protection.



CAUTION: Taco Wood Boiler circulators are designed for indoor use only. Be sure boiler enclosure is weather tight if installed on the boiler.

OPERATING SPECIFICATIONS:

- Maximum Working Pressure: 150 psi (1034 kPa)
- Maximum Operating Temperature: 225°F (107°C)
- Electrical Rating: 115V/60Hz/1Ph

REMOVAL OF EXISTING PUMP FROM SYSTEM PIPING:

1. Disconnect and lock-out electrical supply to pump.
2. Close isolation valves on suction and discharge sides of pump. If valves are not installed, the system may need to be drained.



CAUTION: To prevent injury, allow system water to cool to 100°F before removing old pump or draining system. Leave drain valve open until service/replacement is complete.

3. Remove capacitor box cover and disconnect electrical supply lines to pump.
4. Loosen flange bolts and shift pump body slightly to relieve any remaining system pressure.
5. Remove flange nuts/bolts and pump from system.

INSTALLATION OF WOOD BOILER SERIES CIRCULATOR:



WARNING: Do not use in swimming pool or spa areas; pump has not been investigated for this application.



WARNING: To avoid electrical shock, disconnect the power supply to the circulator and the main electrical unit.



CAUTION: When installing electrical connections, do not apply mechanical loads to the capacitor box; otherwise, retaining screws may be pulled out of the housing, making circulator unusable.



CAUTION:

1. The addition of petroleum based fluids or certain chemical additives to systems utilizing TACO equipment voids the warranty.

2. Use supply wires suitable for 90°C – ATTENTION: Employer des fils d'alimentation adéquats pour 90°C.



CAUTION: Installations at higher elevations over 5000 feet must have higher fill pressure of 20 psi minimum to prevent pump cavitation and flashing. Premature failure may result. Adjust expansion tank pressure to equal fill pressure. A larger size expansion tank may be required.

A. Location:

- Install pump with sufficient room for future inspection, maintenance and service.
- It is recommended that isolation valves be installed on the pump suction and discharge to simplify future service or replacement without draining the system.
- Install pump at location with highest net positive suction head available (NPSHA), usually at the boiler supply outlet.



CAUTION: This pump has a mechanical seal which may require service. Allow access for periodic inspection and leak detection. Provide adequate drainage to prevent property damage.

- Using teflon tape or high quality thread sealant, install Taco companion flanges on threaded pipe ends to ensure proper fit-up and leak protection.

WOOD BOILER SERIES COMPANION FLANGE SETS

CONNECTION	3/4"	1"	1 1/4"	1 1/2"
Iron NPT	110-251F	110-252F	110-253F	110-254F
Stainless Steel NPT	110-251SF	110-252SF	110-253SF	110-254SF
Bronze SWT	110-523BSF	110-524BSF	110-525BSF	110-526BSF
Shut-Off NPT	SF-075T	SF-100T	SF-125T	SF-150T
Shut-Off SWT	SF-075S	SF-100S	SF-125S	SF-150S

- Minimize pipe strain on pump by using pipe hangers on the suction and discharge lines.
- Position vertical and horizontal piping so bolt-holes on pump and companion flanges match. Do not force the suction and discharge lines into position. This may create excess stress on the pump casing and flanges.

B. Mounting Position:

- Always install pump with the motor shaft in the horizontal position and the capacitor/conduit box oriented on top of the motor housing, as shown in Fig. 1.
- Standard pump body mounting position is with the flow in the up-discharge direction (body position #3). The pump body may be field-rotated in any direction to accommodate system piping and flow direction.

- Be sure to align the arrow on the casing with desired flow direction.



CAUTION: Do not support, suspend or brace pump motor or early failure may result. Support provided by casing is sufficient for structural integrity of pump

C. Electrical Wiring:

- All electrical wiring must be installed by a licensed electrician in accordance with local and national codes and regulations.
 - Electrical supply and grounding wires must be suitable for at least 90°C (194°F).
 - Wood Boiler Series circulators are thermally protected and do not require external overload protection.
- Be sure all electrical power to pump is disconnected and locked-out before proceeding with wiring.
 - Loosen capacitor/conduit box screw and remove cover.
 - Attach appropriate size connector to one of the two knock-out holes in the capacitor/conduit box.
 - Using minimum 18 AWG wire, connect the hot and neutral leads from the electrical supply to the respective black and white leads in the capacitor box.
 - Connect the ground wire to the green ground screw in the capacitor box.
 - Replace capacitor/conduit box cover.
 - Insert plastic plug provided in unused knock-out hole.

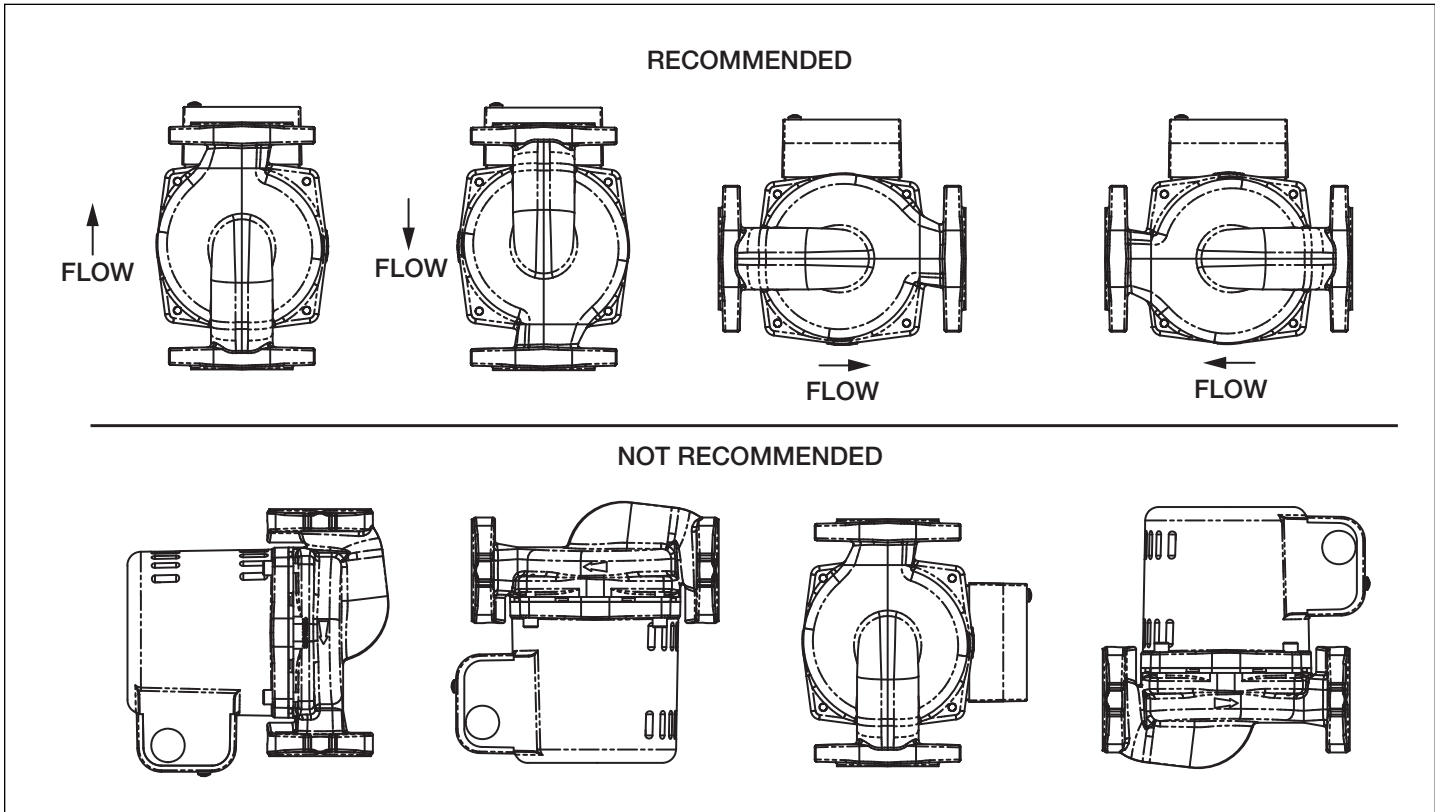

Fig. 1 – Installation Positions

SYSTEM START-UP:



CAUTION: Do not start the pump until the system has been completely filled and vented. Running the pump dry may damage the mechanical seal and void warranty.

1. Prior to pump start-up, the system should be thoroughly cleaned, flushed and drained to prevent damage to seal surfaces.
2. Open isolation valves and re-fill system with clean water. Check for any leaks.
3. Vent all air from system at an air vent located at the high point in the system.
4. Start circulator to check for proper operation.

PERIODIC INSPECTION, MAINTENANCE:

Taco Wood Boiler Series Hi-Capacity circulators are designed to provide years of trouble-free service. However, periodic inspection and routine maintenance is recommended for all hydronic systems and mechanical equipment. If any evidence of leakage or damage is present, take preventive steps to repair or replace the circulator immediately.

REPLACING THE MECHANICAL SEAL: Refer to Fig. 2 on back page.

1. Follow steps 1 thru 5 in section "Removal of existing pump from system piping".
2. Loosen the four body bolts that attach the motor housing to the casing. While supporting the motor, remove the four bolts and carefully remove the motor and impeller assembly from the casing.
3. To remove the impeller, first insert a screwdriver into the motor ventilation slots to make contact with one of the rotor cooling fins. While holding the rotor in place with the screwdriver, turn the impeller clockwise to loosen and remove from shaft.



CAUTION: Do not allow screwdriver to make contact with motor windings or insulation. Permanent damage to motor may result.

4. Remove the seal assembly from the shaft.
5. Remove the face plate from the motor housing. To remove face plate, gently pry it away from the housing.
6. Remove the old seal seat and cup. Lubricate the new cup with soapy water and install new parts in the face plate recess. Replace the face plate to its original position. Carefully tap the face plate evenly into the recess in the motor housing.
7. Clean the impeller shaft before installing the new seal.
8. Lubricate the impeller shaft with soapy water. Do not install new seal on a dry impeller shaft or damage to seal may result.
9. Slide the new carbon seal and spring assembly onto the shaft until it contacts the silicon-carbide seal seat.
10. While holding the rotor in place as in Step 3, thread the impeller onto the shaft in a counter-clockwise direction until it stops. Check to make sure the pump will rotate. If the impeller will not spin freely, contact Taco Technical Support at 1-401-942-8000.



CAUTION: Do not allow screwdriver to make contact with motor windings or insulation. Permanent damage to motor may result.

11. Remove old body gasket, clean the recess in the pump casing and install the new body gasket provided.
12. Attach the pump casing to the motor housing and secure with the four body bolts. Be sure flow arrow is pointing in proper direction. Tighten the four bolts evenly in a criss-cross pattern to 65 in-lb of torque. There should be a small, even gap between the casing and the motor mounting bracket.
13. Re-install circulator into system using new flange gaskets. Refer to section "Installation of Wood Boiler Series Circulator" for complete mounting and wiring instructions.

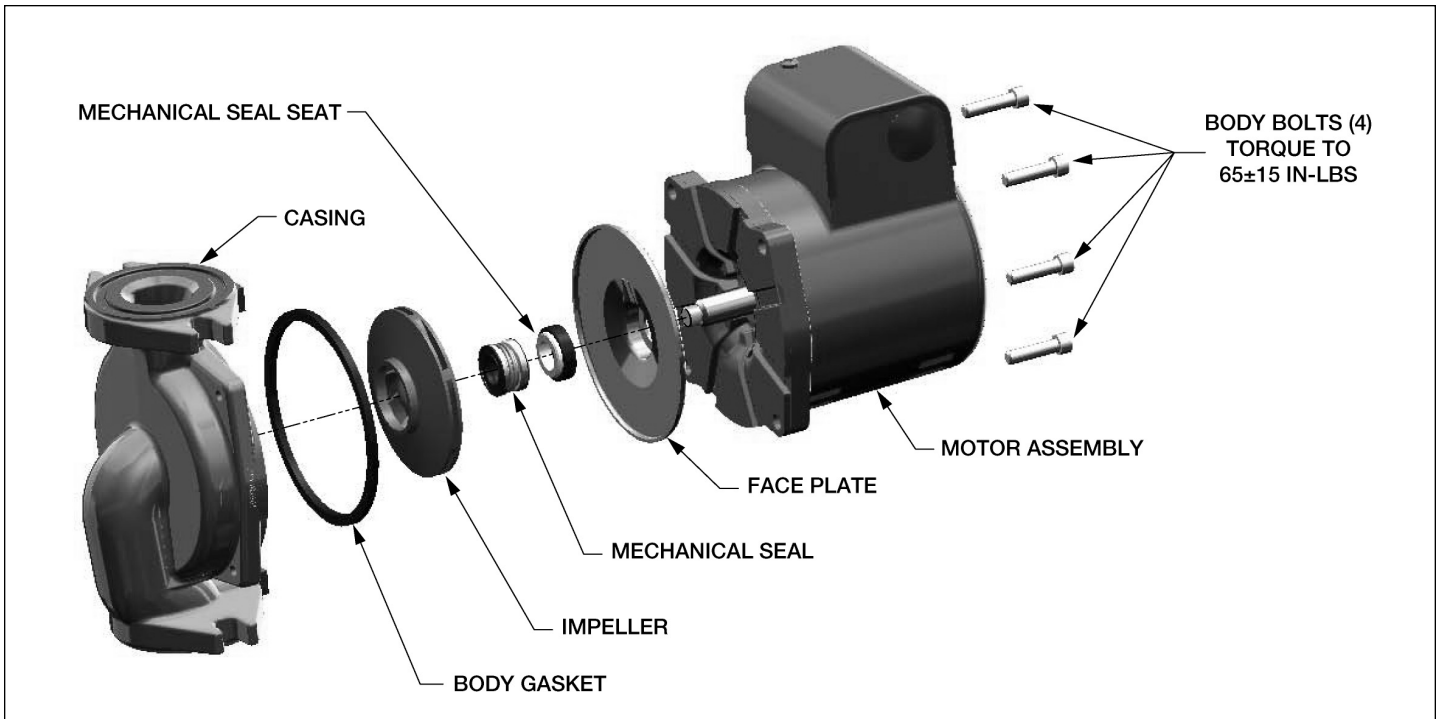

Fig. 2: Exploded View of Pump

LIMITED WARRANTY STATEMENT

Taco, Inc. will repair or replace without charge (at the company's option) any Taco circulator or circulator part which is proven defective under normal use within three (3) years from the date of manufacture.

In order to obtain service under this warranty, it is the responsibility of the purchaser to promptly notify the local Taco stocking distributor or Taco in writing and promptly deliver the subject product or part, delivery prepaid, to the stocking distributor. For assistance on warranty returns, the purchaser may either contact the local Taco stocking distributor or Taco. If the subject product or part contains no defect as covered in this warranty, the purchaser will be billed for parts and labor charges in effect at time of factory examination and repair.

Any Taco product or part not installed or operated in conformity with Taco instructions or which has been subject to misuse, misapplication, the

addition of petroleum-based fluids or certain chemical additives to the systems, or other abuse, will not be covered by this warranty.

If in doubt as to whether a particular substance is suitable for use with a Taco product or part, or for any application restrictions, consult the applicable Taco instruction sheets or contact Taco at (401-942-8000).

Taco reserves the right to provide replacement products and parts which are substantially similar in design and functionally equivalent to the defective product or part. Taco reserves the right to make changes in details of design, construction, or arrangement of materials of its products without notification.

TACO OFFERS THIS WARRANTY IN LIEU OF ALL OTHER EXPRESS WARRANTIES. ANY WARRANTY IMPLIED BY LAW INCLUDING WARRANTIES OF MERCHANTABILITY OR FITNESS IS IN EFFECT ONLY FOR THE DURA-

TION OF THE EXPRESS WARRANTY SET FORTH IN THE FIRST PARAGRAPH ABOVE.

THE ABOVE WARRANTIES ARE IN LIEU OF ALL OTHER WARRANTIES, EXPRESS OR STATUTORY, OR ANY OTHER WARRANTY OBLIGATION ON THE PART OF TACO.

TACO WILL NOT BE LIABLE FOR ANY SPECIAL, INCIDENTAL, INDIRECT OR CONSEQUENTIAL DAMAGES RESULTING FROM THE USE OF ITS PRODUCTS OR ANY INCIDENTAL COSTS OF REMOVING OR REPLACING DEFECTIVE PRODUCTS.

This warranty gives the purchaser specific rights, and the purchaser may have other rights which vary from state to state. Some states do not allow limitations on how long an implied warranty lasts or on the exclusion of incidental or consequential damages, so these limitations or exclusions may not apply to you.

COMFORT MADE EASY®

TACO, INC., 1160 Cranston Street, Cranston, RI 02920 Telephone: (401) 942-8000 FAX: (401) 942-2360.

TACO (Canada), Ltd., 8450 Lawson Road, Unit #3, Milton, Ontario L9T 0J8. Telephone: 905/564-9422. FAX: 905/564-9436.

Visit our web site at: <http://www.taco-hvac.com>

Printed in USA

Copyright 2010

TACO, Inc.