

Taco Radiant Made Easy Application Guide

iSeries-S (Setpoint) Mixing Valve

Products & Applications

PA06

EFFECTIVE: August 15, 2005

SUPERSEDES: March 1, 2004

OVERVIEW

iSeries-S (Setpoint) Mixing Valve

Use the Taco Setpoint iSeries-S Mixing Valves instead of a thermostatic mixing valve for precise dial-in supply water temperature control to a heating system. The direct drive microprocessor-based actuator modulates a 2-way, 3-way or 4-way valve to inject different rates of hot water into the cooler system return water. In combination with the optional boiler protection sensor, the iSeries valves provide the unique benefit of optimal temperature control with boiler protection. The setpoint temperature is adjustable from 80°F to 180°F using a dial located on top of the actuator. A 15°F setback of the supply water can be initiated for additional unoccupied or nighttime setback control. An external multi-status LED indicator light, plug-in wiring connections and an easy to remove actuator makes installation and diagnostics a snap.

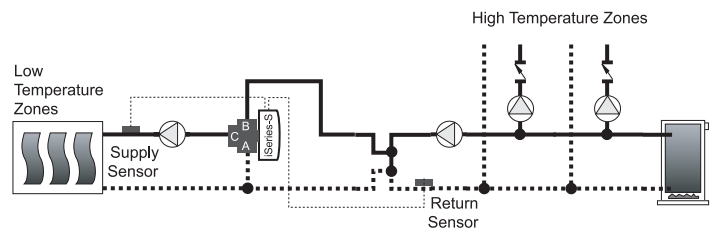

See applications brochure for additional schematics.

DESIGN

When using an iSeries-S Mixing Valve, the following piping requirements must be considered for proper operation (see Figures 1, 2 and 3).

1. In order to hydraulically isolate the boiler loop from the injection or system loop primary/secondary piping must be used. There must be no more than 4 pipe diameters between the tees in the boiler loop (Note 1).
2. There must be at least 6 pipe diameters of straight pipe on either side of the tees (Note 2) in order to prevent the momentum of water in the boiler loop from pushing flow through the injection loop.
3. There should be a minimum of 1 foot drop on the return pipe of the injection loop, in order to create a thermal trap (Note 3) and prevent unwanted heat transfer.
4. When using a 2-way iSeries-S Mixing Valve, a balancing valve must be located between the tees in the system loop, in order to provide a pressure drop to induce flow through the mixing loop.

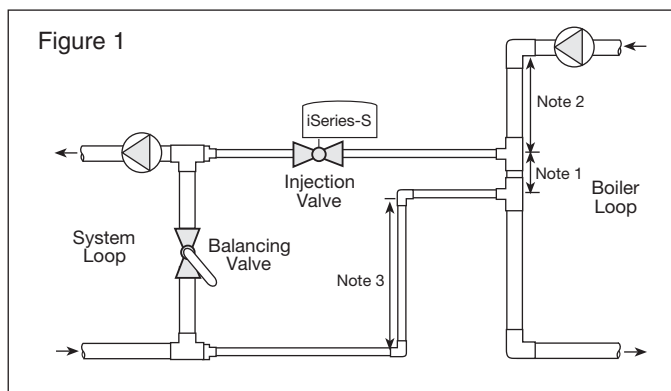

Features:

- 2-way injection or 3-way mixing
- Operates off constant power or relay end switch
- Ball valve design, high Cv
- Manual operation button
- Solid state microprocessor design
- Compact design
- Easy, one-handed actuator removal
- 125 PSI shutoff pressure
- Plug-in low voltage connections
- Multi-status LED indicator light
- Fail safe mode
- Supply sensor included
- Adjustable setpoint dial (80°F to 180°F)
- Selectable 15°F setback
- Optional boiler protection (set at 135°F)

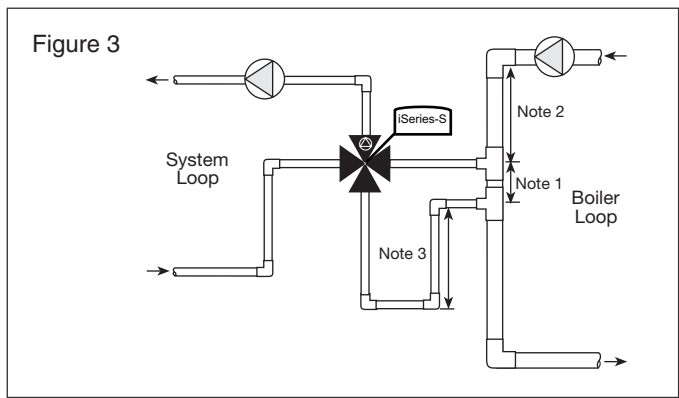
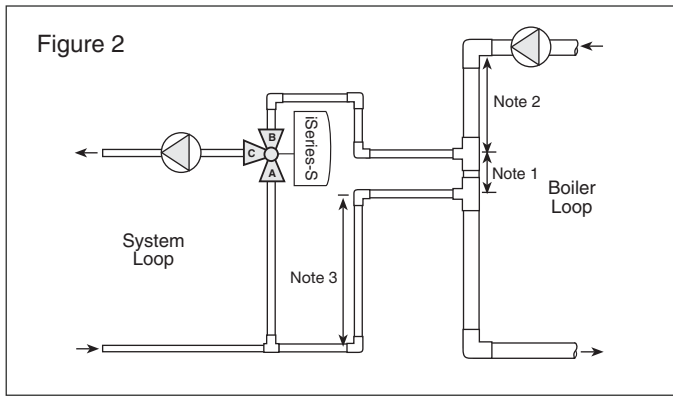

VALVE SIZING AND SELECTION

2-way iSeries-S Mixing Valve Selection

In order to properly size the 2-way iSeries-S Mixing Valve, follow the design procedure below:

- 1) Determine the design radiant heating load.
- 2) Determine the design boiler supply temperature.
- 3) Determine the radiant system return temperature which is based on the design temperature drop across the radiant system.
- 4) Determine the design injection flow rate using the following equation:

$$\text{Eq. 1: Design Injection Flow Rate (US GPM)} = \frac{\text{Design Radiant Heating Load (BTU/hr)}}{500 \times (\text{Boiler Supply} - \text{Radiant System Return})}$$

- 5) From the 2-way Cv chart below, select the valve size with the closest Cv value to the injection flow rate calculated in step 4. Do not size the 2-way iSeries-S Mixing Valve based solely on pipe size.

iSeries: 2-way Cv	
Size	Cv
1/2"	4.9
3/4"	10.3
1"	8.9

3-way iSeries-S Mixing Valve Selection

Select the 3-way iSeries-S Mixing Valve based on the 3-way Pressure Drop chart below.

Flow	iSeries: 3-way Valve Pressure Drop					
	1/2" (Cv = 1.5)		3/4" (Cv = 3.3)		1" (Cv = 3.0)	
	PSI	Ft. Head	PSI	Ft. Head	PSI	Ft. Head
GPM						
1/2	0.11	0.26	0.02	0.05	0.03	0.06
1	0.44	1.03	0.09	0.21	0.11	0.26
1 1/2	1.00	2.31	0.21	0.48	0.25	0.58
2	1.78	4.11	0.37	0.85	0.44	1.03
4	—	—	1.47	3.39	1.78	4.11
6	—	—	3.31	7.64	4.00	9.24
8	—	—	5.88	13.58	—	—

4-way iSeries-S Mixing Valve Selection

Select the 4-way iSeries-S Mixing Valve based on the 4-way Pressure Drop chart below:

Flow	iSeries: 4-way Valve Pressure Drop					
	3/4" (Cv = 7.0)		1" (Cv = 9.3)		1 1/4" (Cv = 17.5)	
	PSI	Ft. Head	PSI	Ft. Head	PSI	Ft. Head
1/2	0.01	0.01	0.00	0.01	0.00	0.00
1	0.02	0.05	0.01	0.03	0.00	0.01
2	0.08	0.19	0.05	0.11	0.01	0.03
4	0.33	0.75	0.18	0.43	0.05	0.12
6	0.73	1.69	0.42	0.96	0.12	0.27
8	1.31	3.01	0.74	1.71	0.21	0.48
10	2.04	4.71	1.16	2.67	0.33	0.75
12	2.94	6.79	1.66	3.84	0.47	1.08
14	4.00	9.24	2.28	5.27	0.64	1.48
16	—	—	2.96	6.84	0.84	1.93
18	—	—	3.76	8.70	1.06	2.44
20	—	—	—	—	2.30	5.31

OPERATION

iSeries-S Power Up and Heat Request

Whenever the iSeries-S is powered up, the LED turns green and the control starts operation. The power to the iSeries-S may be switched through an end switch (e.g. Taco ZVC/SR style zone control), a thermostat for intermittent operation, or a power source (24 vac) may be connected directly to the iSeries-S for continuous operation.

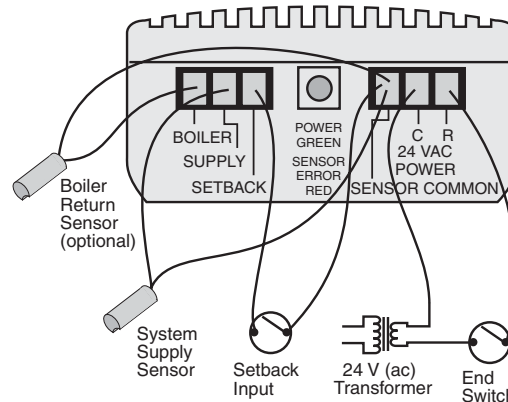

Setpoint

The iSeries-S operates the valve to maintain a fixed setpoint. The setpoint temperature is set using the Setpoint dial located on the top of the actuator. The setpoint range available is from 80°F to 180°F.

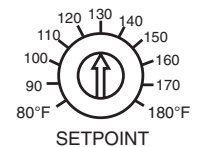

Boiler Protection

An optional boiler return sensor (Taco part #9300-2044RP) can be installed to provide boiler protection. When the boiler return temperature is below 135°F, the green LED flashes rapidly (reduced output) and the iSeries-S modulates towards the closed position in order to allow the boiler temperature to recover.

Setback

The iSeries-S has a setback function used to lower the setpoint target. The setpoint target is lowered by 15°F whenever there is a contact closure across the SETBACK and SENSOR COMMON terminals.

INSTALLATION

2-way Installation

For installations where boiler protection is **NOT** required, the optional boiler sensor does not need to be installed.

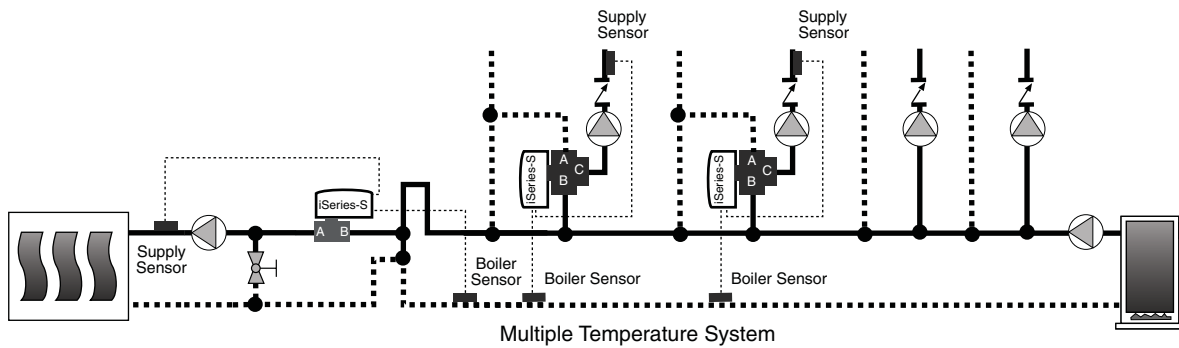
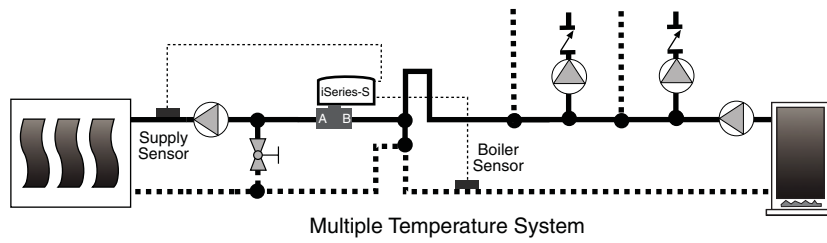
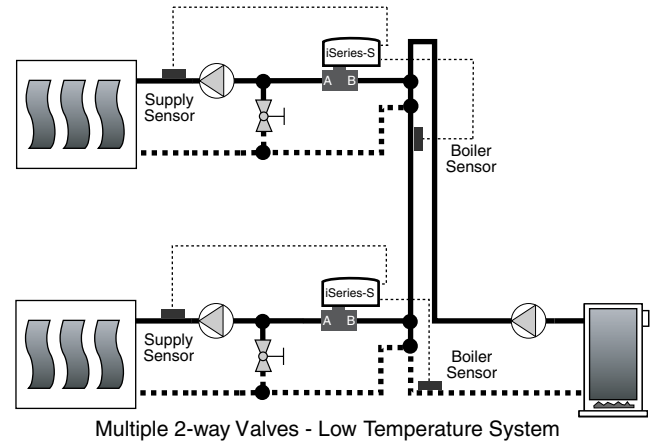
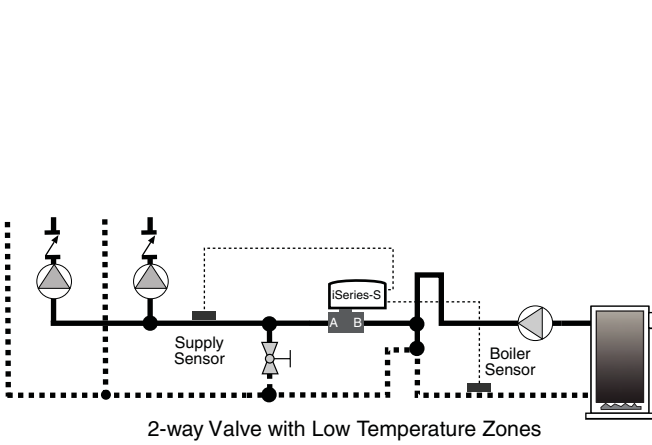
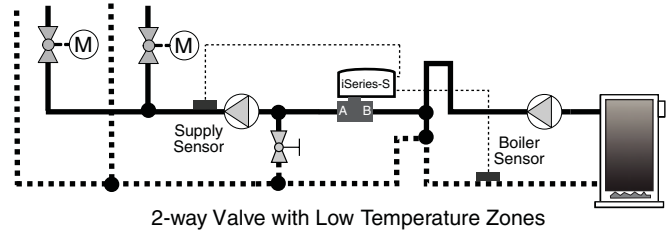
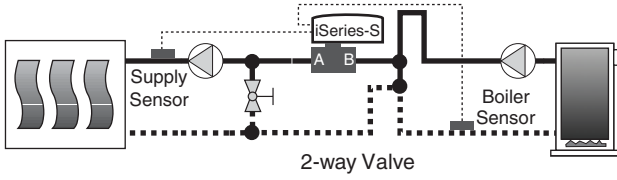

3-way Installation

For installations where boiler protection is **NOT** required, the boiler sensor does not need to be installed.

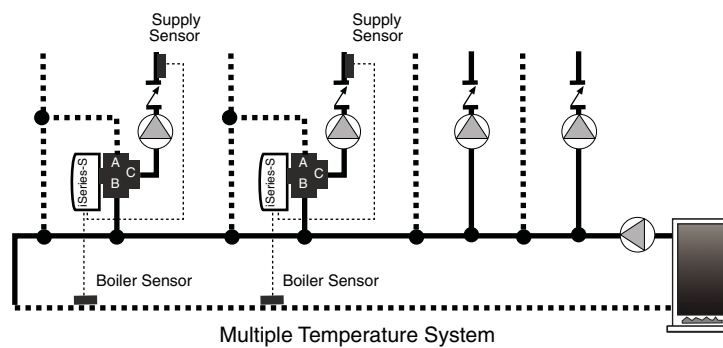
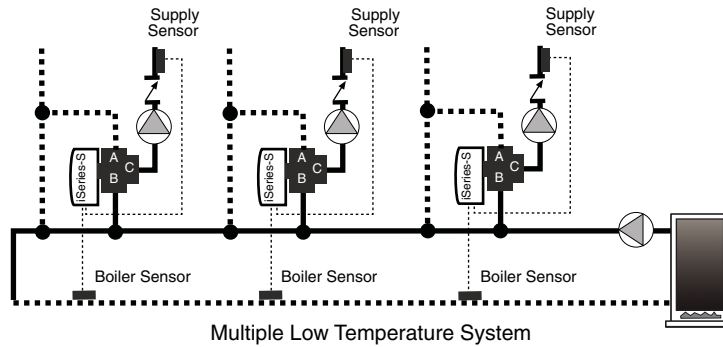
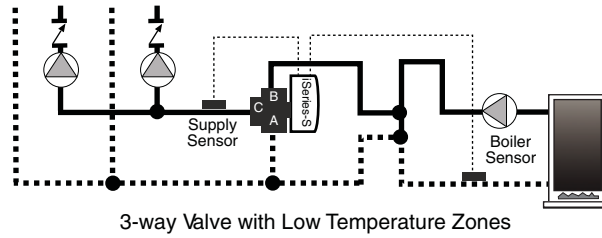
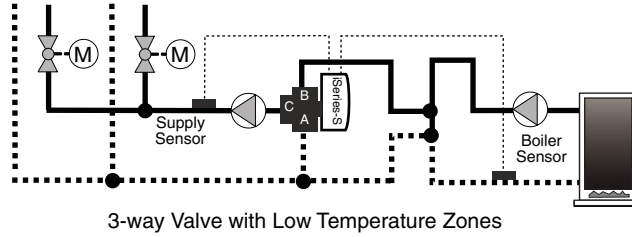
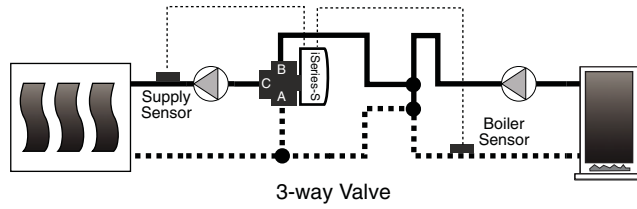

3-way Installation (continued)

For installations where boiler protection is **NOT** required, the boiler sensor does not need to be installed.

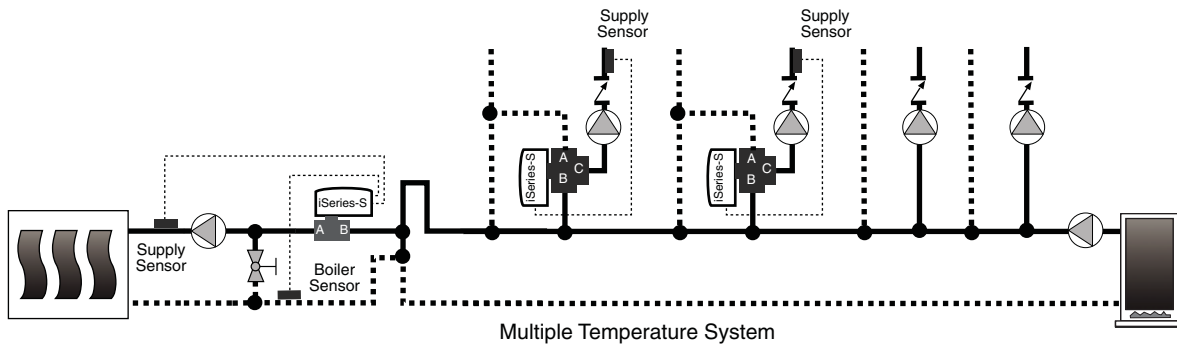
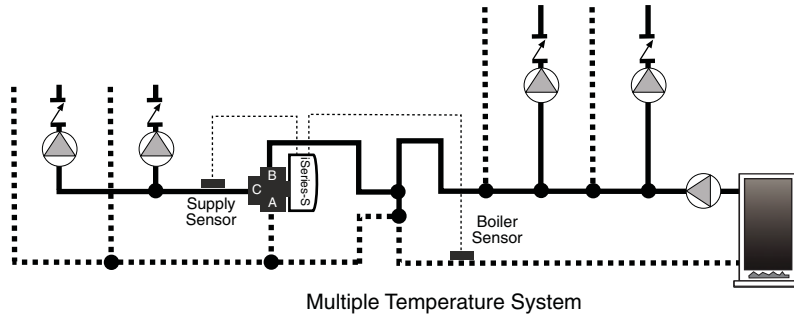
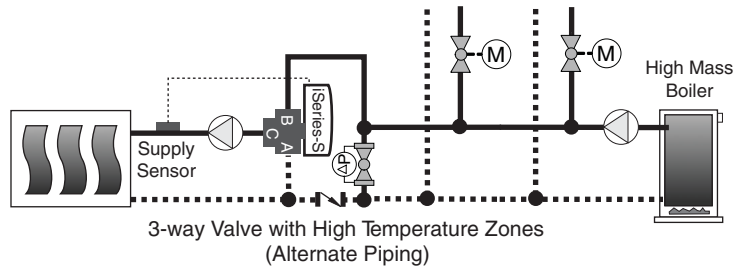
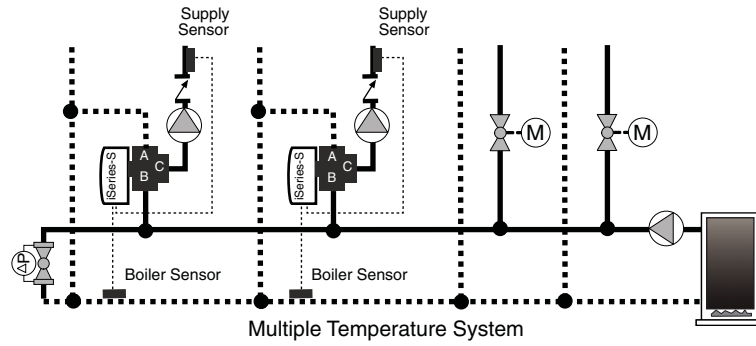

4-way Installation

For installations where boiler protection is **NOT** required, the boiler sensor does not need to be installed.

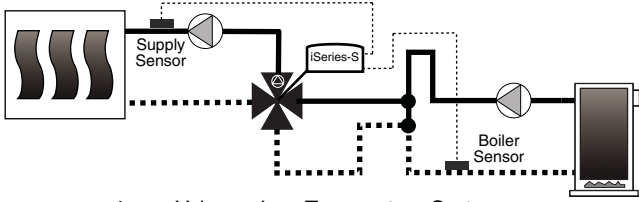

4-way Valve — Low Temperature System

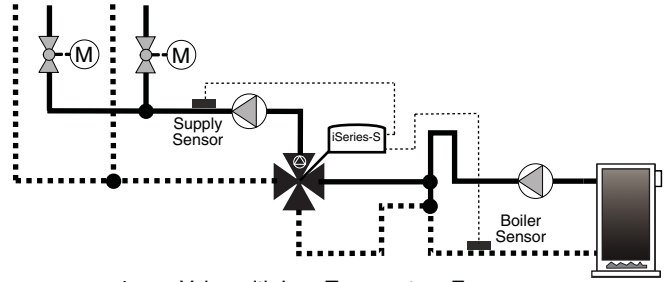

4-way Valve with Low Temperature Zones

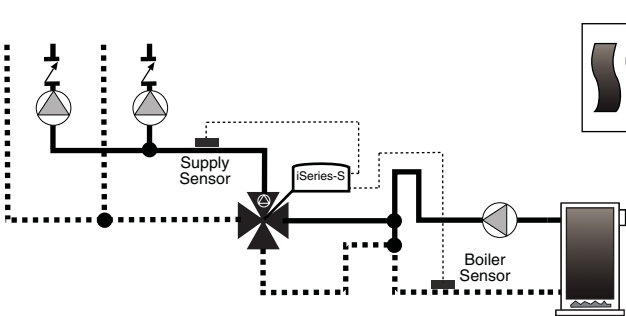

4-way Valve with Low Temperature Zones

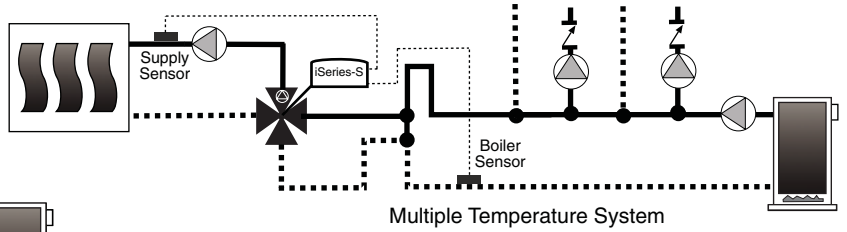

Multiple Temperature System

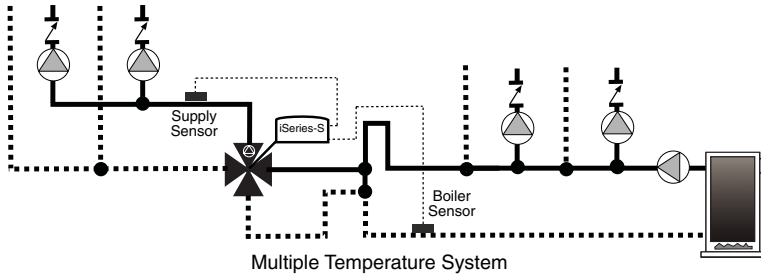

Multiple Temperature System

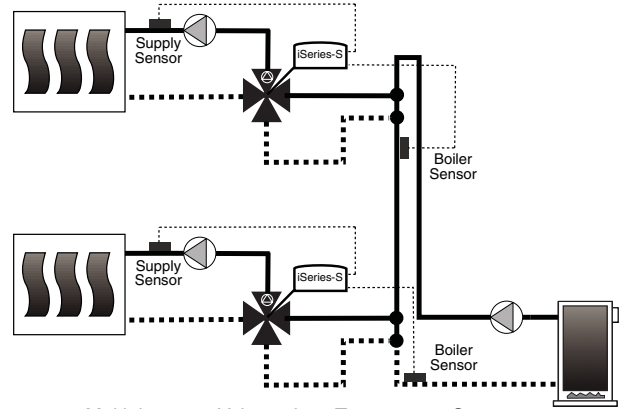

Multiple 4-way Valves - Low Temperature System

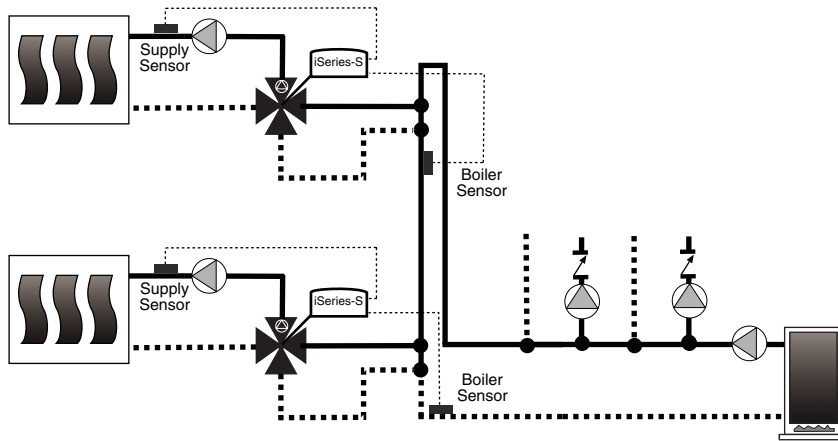

Multiple Temperature System

Radiant Made Easy™

TACO, INC., 1160 Cranston Street, Cranston, RI 02920 Telephone: (401) 942-8000 FAX: (401) 942-2360.

TACO (Canada), Ltd., 6180 Ordan Drive, Mississauga, Ontario L5T 2B3. Telephone: 905/564-9422. FAX: 905/564-9436.

Visit our web site at: <http://www.taco-hvac.com>

Printed in USA
Copyright 2005
TACO, Inc.