

# Dell PowerVault MD3060e Storage Enclosure Deployment Guide



# Notes, Cautions, and Warnings

 **NOTE:** A NOTE indicates important information that helps you make better use of your computer.

 **CAUTION:** A CAUTION indicates either potential damage to hardware or loss of data and tells you how to avoid the problem.

 **WARNING:** A WARNING indicates a potential for property damage, personal injury, or death.

**Copyright © 2014 Dell Inc. All rights reserved.** This product is protected by U.S. and international copyright and intellectual property laws. Dell™ and the Dell logo are trademarks of Dell Inc. in the United States and/or other jurisdictions. All other marks and names mentioned herein may be trademarks of their respective companies.

2014 - 09

Rev. A01

# Contents

<b>1 Introduction.....</b>	<b>4</b>
System Requirements.....	4
Other Information You May Need.....	5
Contacting Dell.....	5
Locating your system service tag.....	5
<b>2 Hardware Installation.....</b>	<b>7</b>
Connecting The Storage Enclosure.....	7
Cabling The Storage Enclosure.....	8
Windows with Storage Spaces Configuration.....	8
Single Server Configurations.....	9
Dual Server Configurations.....	13
Linux.....	17
Linux Single Path Configuration.....	18
Linux Symmetric Multipath Configuration.....	19
Linux Asymmetric Multipath Configuration.....	20
<b>3 Installing The Storage Enclosure Management Software.....</b>	<b>21</b>
Installing Host Bus Adapters And Drivers.....	21
Storage Enclosure Management Installation – Windows.....	21
Graphical Installation.....	21
Console Installation.....	21
Silent Installation.....	21
Storage Enclosure Management Installation – Linux.....	22
Graphical Installation.....	22
Console Installation.....	22
Silent Installation.....	23
<b>4 Uninstalling the Storage Enclosure Management Software.....</b>	<b>24</b>
Windows.....	24
Windows Explorer.....	24
Command Prompt.....	24
Linux.....	24

# Introduction

 **CAUTION:** See the **Safety, Environmental, and Regulatory Information** document for important safety information before following any procedures listed in this document.

An enclosure containing physical disks accessed through EMMs (Enclosure Management Modules) is called a storage enclosure. A storage enclosure includes various hardware components, such as physical disks, EMM's, fans, and power supplies. One or more host servers attached to the storage enclosure can access the data on the storage enclosure. You can also establish multiple physical paths between the host(s) and the storage enclosure so that loss of any single path (for example, through failure of a host server port) does not result in loss of access to data on the storage enclosure.

The storage enclosure is managed by the Storage Enclosure Management software running on a host server. On the host server system, the management software and the storage enclosure communicate management requests and event information using in-band SAS connections.

## Terminology

- Storage Enclosure — When the MD3060e is attached to a server directly or other MD3060e enclosures, it is referred to as a Storage Enclosure. This document applies to the deployment and configuration of the MD3060e as a Storage Enclosure.
- Expansion Enclosure — When the MD3060e is used as an MD3 (MD32/MD34/MD36/MD38) Series Storage Array expansion it is referred to as an Expansion Enclosure. For documentation for the use of the MD3060e as an Expansion Enclosure, please refer to the MD3 Series Storage Array Administrator's Guide. These documents can be found at [dell.com/support](http://dell.com/support).

The deployment process includes:

- Hardware installation
- Initial system configuration
- Storage Enclosure Management Software installation

 **NOTE:** For more information on product documentation, see Related Documentation.

The Storage Enclosure Management Software tools enables an administrator to monitor and update the storage enclosure for optimum usability. The Storage Enclosure Management Software is supported on various Microsoft Windows and Linux operating systems. For details on specific supported operating systems, please refer the MD3060e Support Matrix at [dell.com/support/manuals](http://dell.com/support/manuals).

## System Requirements

Before installing and configuring the PowerVault MD3060e hardware and software, ensure that the supported operating system is installed and minimum system requirements are met. For more information, see the *Dell PowerVault MD3060e Support Matrix* at [dell.com/Support/Manuals](http://dell.com/Support/Manuals).

-  **NOTE:** Dell supports Microsoft Windows and Linux host operating systems with the MD3060e storage enclosure. For more details on the specific OS's supported by the MD3060e storage enclosure, please see the *Dell PowerVault MD3060e Support Matrix* at [dell.com/support/manuals](http://dell.com/support/manuals).

## Other Information You May Need

-  **NOTE:** For all PowerVault documentation, go to [dell.com/support/manuals](http://dell.com/support/manuals) and enter the system Service Tag to get your system documentation.

Your product documentation includes:

- *Dell PowerVault MD3060e Getting Started Guide* — Provides an overview of system features, setting up your system, and technical specifications. This document is also shipped with your system.
- *Dell PowerVault MD3060e Storage Enclosure Administrators Guide* — Provides information about how to configure, manage, and update your MD3060e Storage Enclosure. This document is available online at [dell.com/support/manuals](http://dell.com/support/manuals).
- *Dell PowerVault MD3060e Owner's Manual* — Provides information about system hardware features and describes how to troubleshoot the system and install or replace system components. This document is available online at [dell.com/support/manuals](http://dell.com/support/manuals).
- *Dell PowerVault MD 3060e Support Matrix* — Provides information about the software and hardware compatibility for the MD3060e storage enclosure.

## Contacting Dell

-  **NOTE:** Dell provides several online and telephone-based support and service options. If you do not have an active Internet connection, you can find contact information on your purchase invoice, packing slip, bill, or Dell product catalog. Availability varies by country and product, and some services may not be available in your area.

To contact Dell for sales, technical support, or customer-service issues:

1. Go to [dell.com/support](http://dell.com/support).
2. Select your country from the drop-down menu on the top left corner of the page.
3. For customized support:
  - a. Enter your system service tag in the **Enter your Service Tag** field.
  - b. Click **Submit**.The support page that lists the various support categories is displayed.
4. For general support:
  - a. Select your product category.
  - b. Select your product segment.
  - c. Select your product.The support page that lists the various support categories is displayed.

## Locating your system service tag

Your system is identified by a unique Express Service Code and Service Tag number. The Express Service Code and Service Tag are found on the front of the system by pulling out the information tag.

Alternatively, the information may be on a sticker on the chassis of the system. This information is used by Dell to route support calls to the appropriate personnel.

# Hardware Installation

Before using this guide, ensure that you review the instructions in the:

- *MD3060e Getting Started Guide* — Provides an overview of system features, setting up your system, and technical specifications. This document is also shipped with your system.
- *MD3060e Storage Enclosure Administrators Guide* — Provides information about how to configure, manage, and update your MD3060e Storage Enclosure. This document is available online at [dell.com/support/manuals](http://dell.com/support/manuals).
- The Rack Installation instructions — Provides information on how to rack your system. This document is shipped with your system.

## Connecting The Storage Enclosure

The storage enclosure is connected to a host(s) using one or both of the two EMM's (Enclosure Management Modules). The EMM's are identified as EMM 0 and EMM 1. The ports on the EMM's and their functions are listed below:

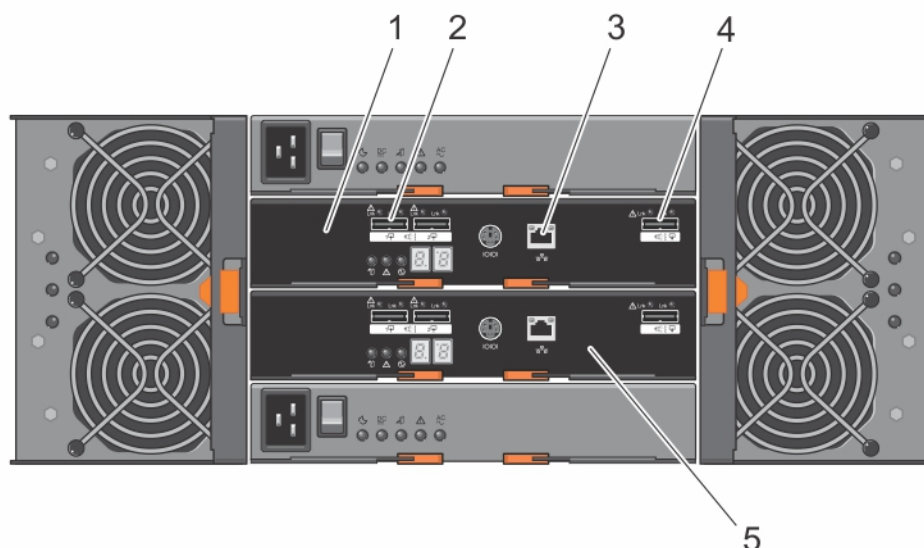

**Figure 1. Ports on the MD 3060e Storage Enclosure**

1. EMM 0 — Enclosure Management Module
2. SAS Host Ports — Allows you to connect host servers to the storage enclosure.

3. Ethernet Port — Not used.
4. SAS OUT Port — Enables the Storage Enclosure to be connected to another Storage Enclosure
5. EMM 1 — Enclosure Management Module

## Cabling The Storage Enclosure

There are a number of ways to cable the MD3060e storage enclosure to host servers and to additional MD3060e storage enclosures. The particular configuration chosen will depend on desired storage capacity, desired level of resiliency of both the server and storage enclosure and the operation system being utilized. .

 **NOTE:** The maximum supported SAS cable length is 4 meters.

 **NOTE:** All connections from host server to storage enclosure and from storage enclosure to storage enclosure are made using SAS cables with SFF-8088 mini-SAS connectors.

## Windows with Storage Spaces Configuration

Windows Server 2012 R2 includes a feature called with Storage Spaces. Storage Spaces is a feature that allows you to group drives together into a storage pool. Then you can use pool capacity to create storage spaces. Storage spaces are virtual drives that can be used by Windows the same way a physical drive would be used. Please refer to Microsoft documentation of the Windows Storage Spaces feature for more information.

 **NOTE:** If multiple connections are used to attach the enclosure, Dell recommends MPIO to be configured with the Failover Only Policy for all drives in the enclosure.

The MD3060e supports Storage Spaces using up to four storage enclosures. Full support of Storage Spaces requires each connection to a single EMM from a single host to be from separate HBA's within the host.

### Storage Spaces Configuration Limits

The following are the recommended configuration limits when using Storage Spaces configurations:

- For clustered storage pools:
  - Up to 80 physical disks in a clustered storage pool (to allow time for the pool to fail over to other nodes)
  - Up to four storage pools per cluster
  - Up to 64 storage spaces in a single pool
- For non-clustered storage pools:
  - Up to 128 storage spaces in a single storage pool
  - Up to 240 physical disks in a non-clustered Windows Server 2012 R2 storage pool
- For both clustered and non-clustered pools:
  - Up to 480 TB of capacity in a single storage pool



Recommended cabling diagrams for the maximum configurations and tables are shown below:

## Single Server Configurations

### Single Server Dual HBA Symmetric Configuration

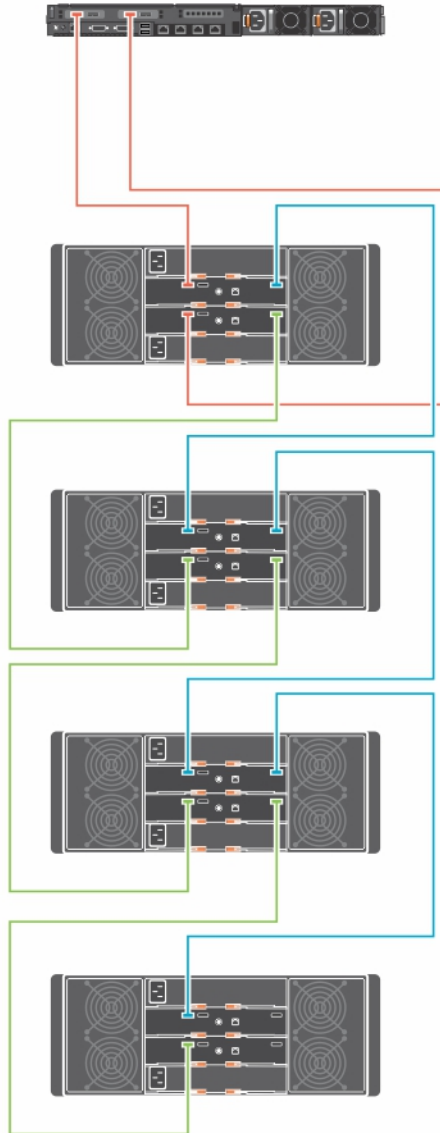

Figure 2. Single Server Dual HBA Symmetric Cabling Diagram

### Single Server Dual HBA Asymmetric Configuration

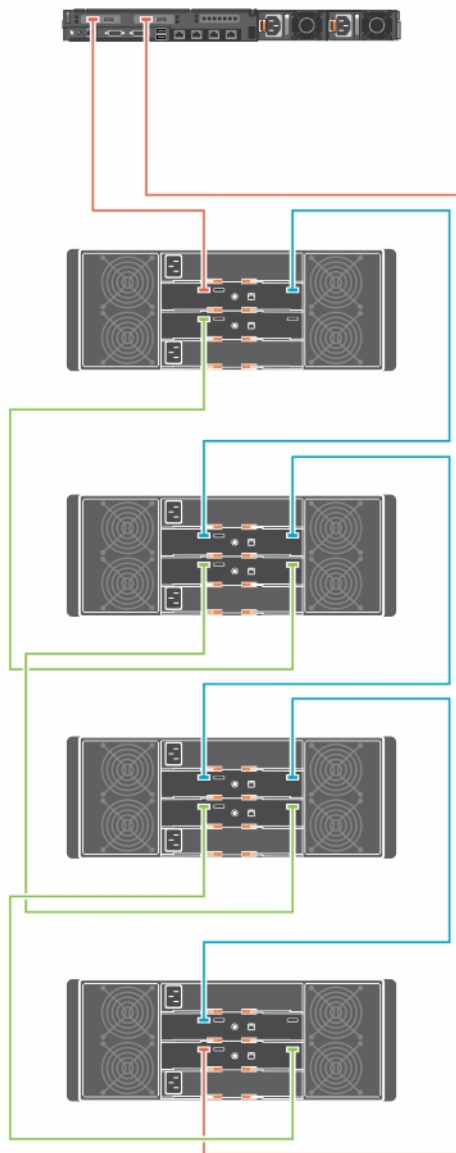

Figure 3. Single Server Dual HBA Asymmetric Cabling Diagram

## Single Server 3 HBA up to 3 enclosures High Availability Configuration

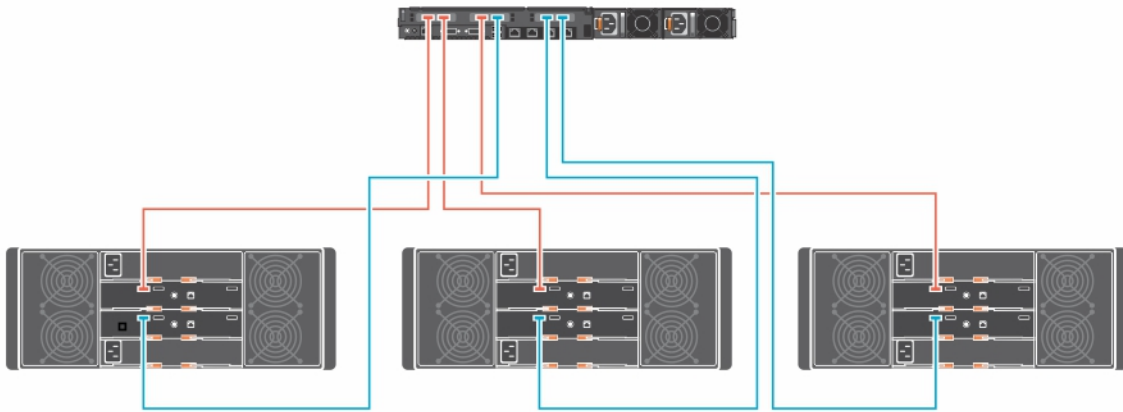

Figure 4. Single Server 3 HBA up to 3 enclosures High Availability Cabling Diagram

**NOTE:** For more details on Dell servers that support 2 or more HBA's please see the *Dell PowerVault MD3060 Support Matrix* at [dell.com/powervaultmanuals](http://dell.com/powervaultmanuals).

Table 1. Single Server 3 HBA up to 3 enclosures High Availability Cabling Table

	Host Server 1	
<b>Cable Color Coding</b>	■	■
Enclosure 1	HBA 0-EMM 0 Port 0	HBA 1-EMM 1 Port 0
Enclosure 2	HBA 0-EMM 0 Port 0	HBA 2-EMM 1 Port 0
Enclosure 3	HBA 1-EMM 0 Port 0	HBA 2-EMM 1 Port 0

## Single Server 4 HBA up to 4 enclosures High Availability Configuration

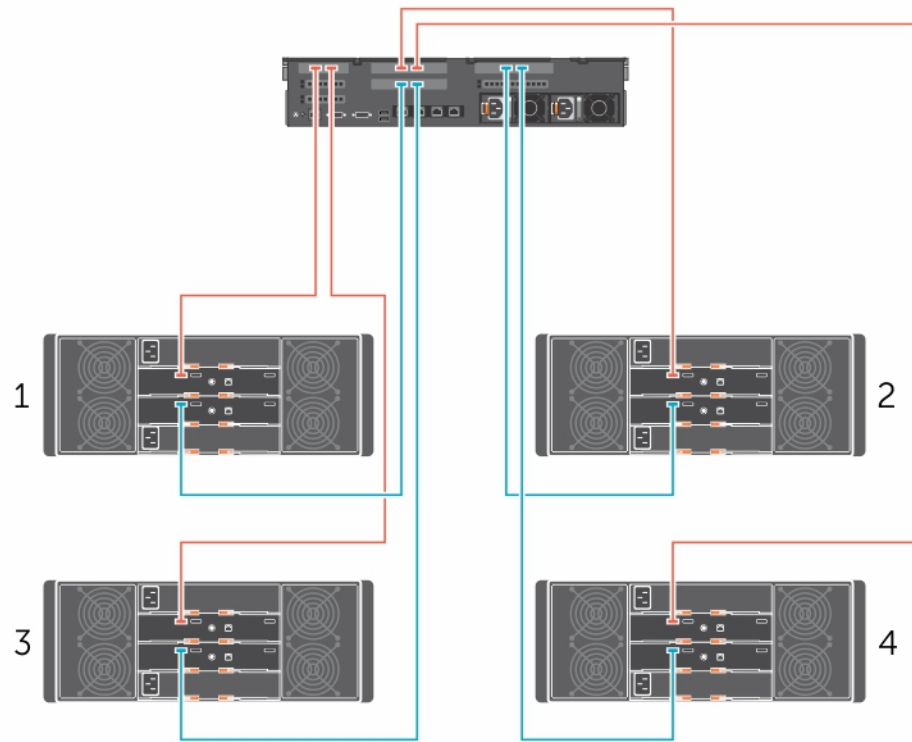

Figure 5. Single Server 4 HBA up to 4 enclosures High Availability Cabling Diagram

**NOTE:** For more details on Dell servers that support 2 or more HBA's please see the *Dell PowerVault MD3060 Support Matrix* at [dell.com/powervaultmanuals](http://dell.com/powervaultmanuals).

Table 2. Single Server 4 up to 4 enclosures HBA High Availability Cabling Table

	Host Server 1	
<b>Cable Color Coding</b>	■	■
Enclosure 1	HBA 0-EMM 0 Port 0	HBA 2-EMM 1 Port 0
Enclosure 2	HBA 1-EMM 0 Port 0	HBA 3-EMM 1 Port 0
Enclosure 3	HBA 0-EMM 0 Port 0	HBA 2-EMM 1 Port 0
Enclosure 4	HBA 1-EMM 0 Port 0	HBA 3-EMM 1 Port 0

## Dual Server Configurations

### Dual Server Cluster Dual HBA Maximum Symmetric Configuration

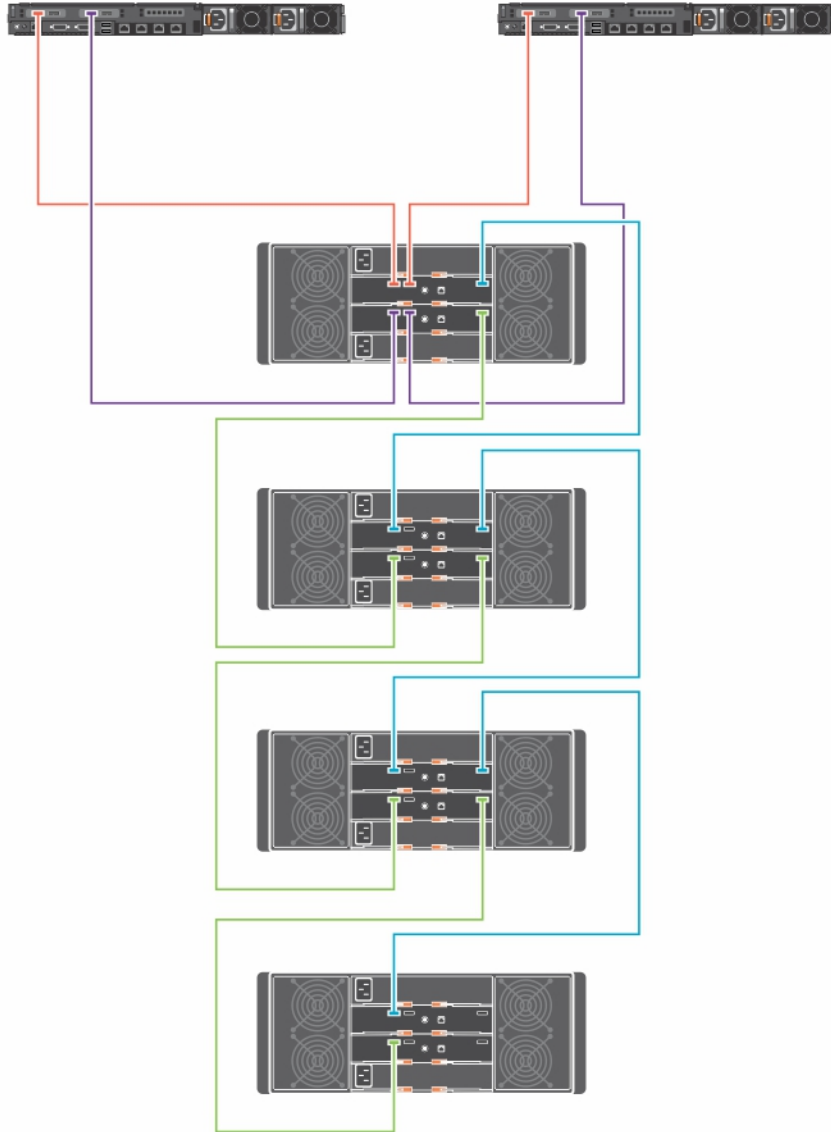

Figure 6. Dual Server Cluster Dual HBA Maximum Symmetric Cabling Diagram

## Dual Server Cluster Dual Quad Port HBA 4 Enclosure High Availability Configuration

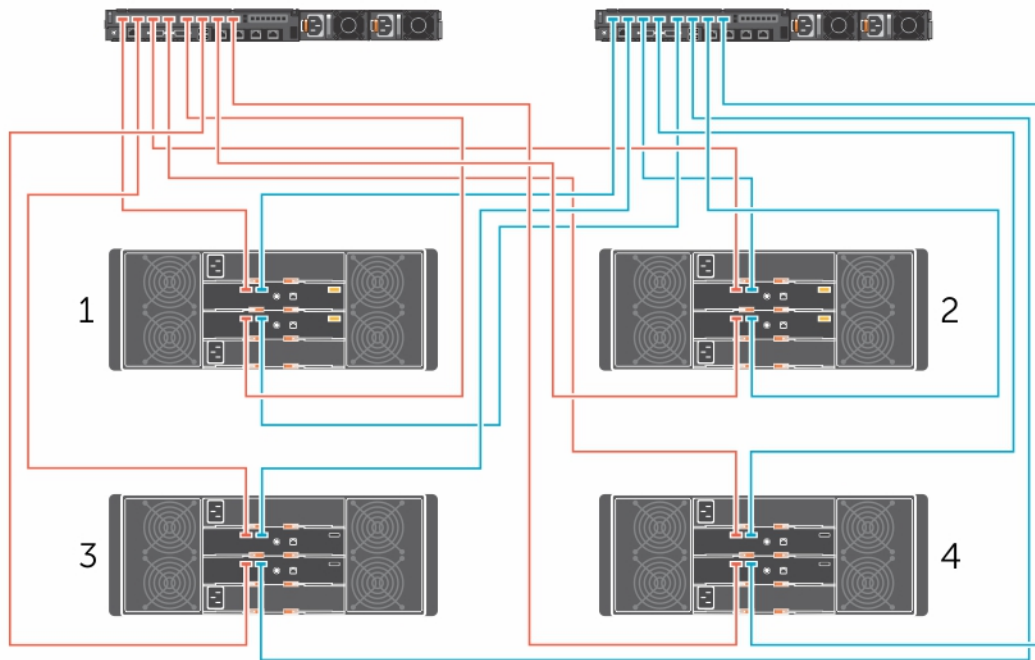

Figure 7. Dual Server Cluster Dual Quad Port HBA 4 Enclosure High Availability Cabling Diagram

Table 3. Dual Server Cluster Dual Quad Port HBA Maximum High Availability Cabling Table

	Cable Color Coding	Host Server 1	Cable Color Coding	Host Server 2
Enclosure 1	■	HBA 0-EMM 0 Port 0	■	HBA 0-EMM 0 Port 1
		HBA 1-EMM 1 Port 0		HBA 1-EMM 1 Port 1
Enclosure 2	■	HBA 0-EMM 0 Port 0	■	HBA 0-EMM 0 Port 1
		HBA 1-EMM 1 Port 0		HBA 1-EMM 1 Port 1
Enclosure 3	■	HBA 0-EMM 0 Port 0	■	HBA 0-EMM 0 Port 1
		HBA 1-EMM 1 Port 0		HBA 1-EMM 1 Port 1
Enclosure 4	■	HBA 0-EMM 0 Port 0	■	HBA 0-EMM 0 Port 1
		HBA 1-EMM 1 Port 0		HBA 1-EMM 1 Port 1

## Dual Server Cluster 3 HBAs with 3 Enclosures High Availability Configuration

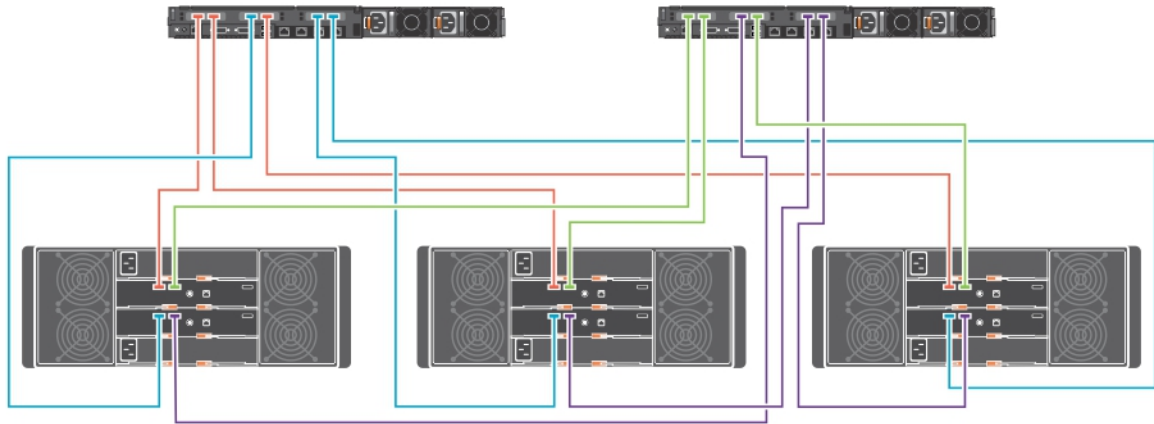

Figure 8. Dual Server Cluster 3 HBAs with 3 Enclosures High Availability Cabling Diagram

Table 4. Dual Server Cluster 3 HBAs with 3 Enclosures High Availability Cabling Table

	Cable Color Coding	Host Server 1	Cable Color Coding	Host Server 2
Enclosure 1	■	HBA 0-EMM 0 Port 0	■	HBA 0-EMM 0 Port 1
	■	HBA 1-EMM 1 Port 0	■	HBA 1-EMM 1 Port 1
Enclosure 2	■	HBA 0-EMM 0 Port 0	■	HBA 0-EMM 0 Port 1
	■	HBA 1-EMM 1 Port 0	■	HBA 1-EMM 1 Port 1
Enclosure 3	■	HBA 1-EMM 0 Port 0	■	HBA 0-EMM 0 Port 1
	■	HBA 2-EMM 1 Port 0	■	HBA 1-EMM 1 Port 1

## Dual Server Cluster 4 HBAs with 4 enclosures High Availability Configuration

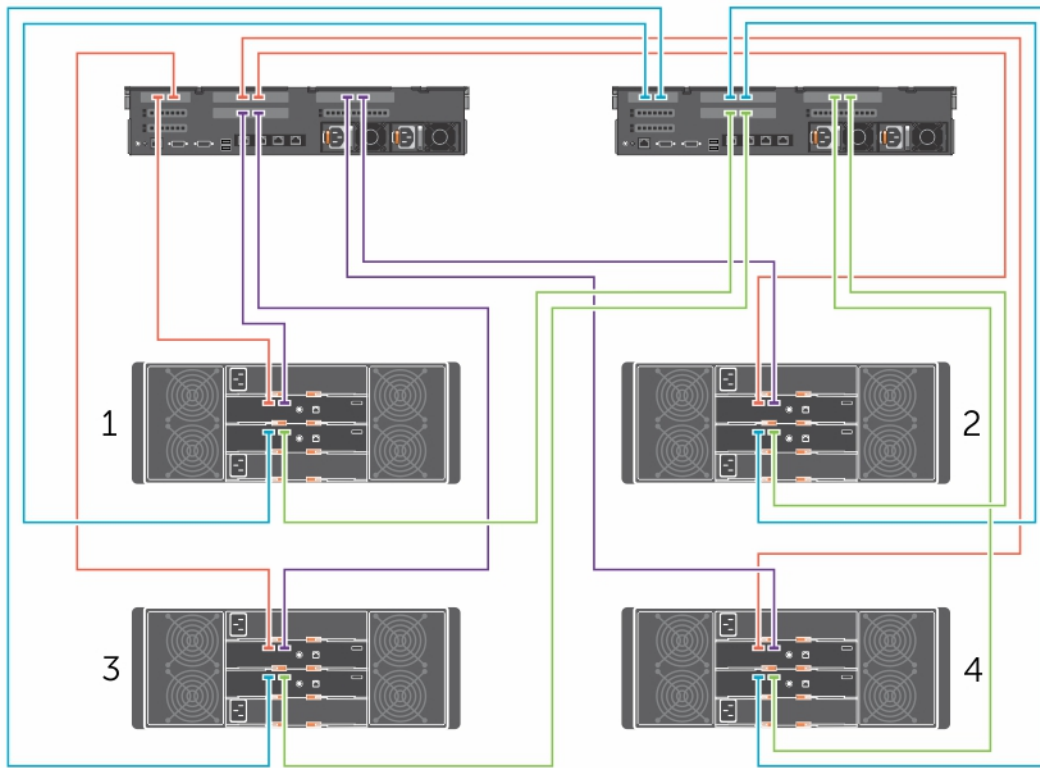

Figure 9. Dual Server Cluster 4 HBAs with 4 enclosures High Availability Cabling Diagram

Table 5. Dual Server Cluster 4 HBAs with 4 enclosures High Availability Cabling Table

	Cable Color Coding	Host Server 1	Cable Color Coding	Host Server 2
Enclosure 1	■	HBA 0-EMM 0 Port 0	■	HBA 0-EMM 1 Port 0
	■	HBA 2-EMM 0 Port 1	■	HBA 2-EMM 1 Port 1
Enclosure 2	■	HBA 1-EMM 0 Port 0	■	HBA 1-EMM 1 Port 0
	■	HBA 3-EMM 0 Port 1	■	HBA 3-EMM 1 Port 1
Enclosure 3	■	HBA 0-EMM 0 Port 0	■	HBA 0-EMM 1 Port 0
	■	HBA 2-EMM 0 Port 1	■	HBA 2-EMM 1 Port 1
Enclosure 4	■	HBA 1-EMM 0 Port 0	■	HBA 1-EMM 1 Port 0
	■	HBA 3-EMM 0 Port 1	■	HBA 3-EMM 1 Port 1



# Linux

There are three configurations supported for Linux host servers:

- Single Path — This configuration utilizes a simplified cabling scheme, but does not provide redundancy or fault tolerance. It should only be used when the operating system or a higher-level application is being utilized for data resiliency.
- Symmetric Multipath — A cascading configuration that provides path redundancy, but does not provide against enclosure loss.
- Asymmetric Multipath — High availability configuration that allows the host server to reach any enclosure if a path or single enclosure is lost

For multipath configurations, Linux Device Mapper Multipath (DMMP) must be configured. Dell recommends the Failover Policy. To ensure proper functionality, verify the following values are set in `/etc/multipath.conf`:

- `path_grouping_policy` **failover**
- `failback` **manual**



**NOTE:** For more details on supported Linux OS's please see the MD3060 Storage Enclosure Support Matrix.

## Linux Single Path Configuration

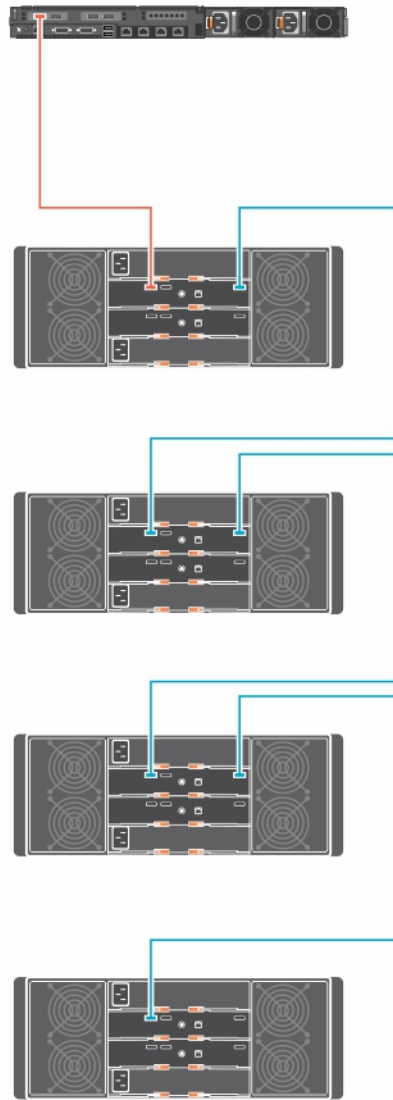

Figure 10. Linux Single Path Cabling Diagram

## Linux Symmetric Multipath Configuration

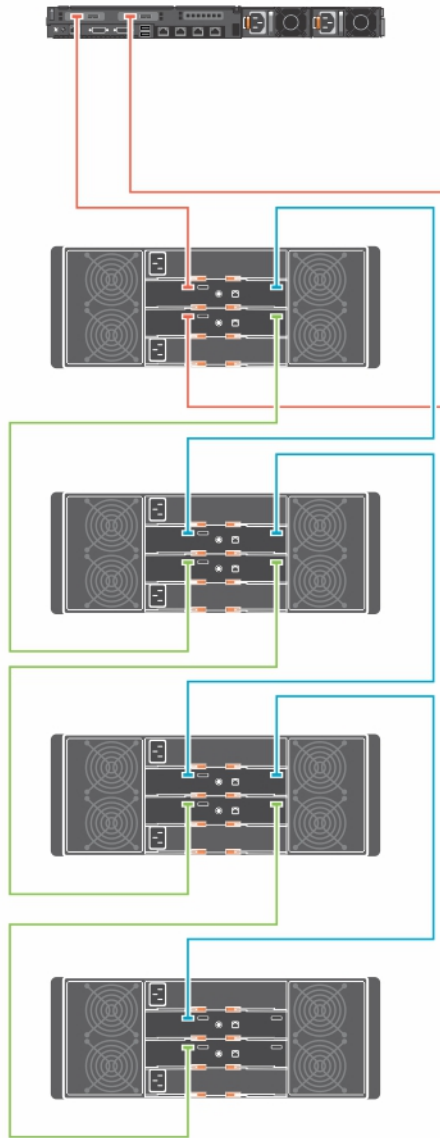

Figure 11. Linux Symmetric Multipath Cabling Diagram

## Linux Asymmetric Multipath Configuration

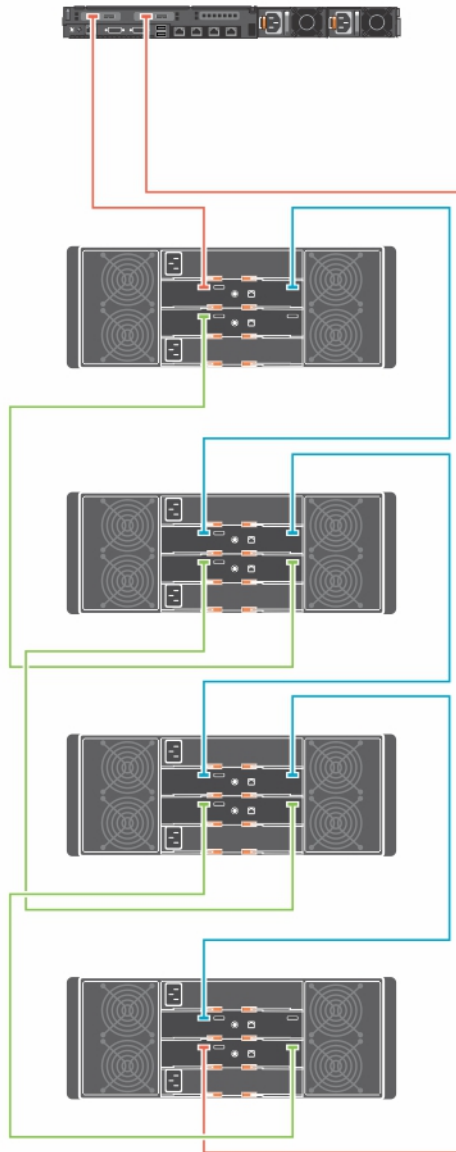

Figure 12. Linux Asymmetric Multipath Cabling Diagram

# Installing The Storage Enclosure Management Software

## Installing Host Bus Adapters And Drivers

1. Install the host bus adapters (HBAs).
2. Connect the cables.
3. Install the HBA drivers and the operating system HBA patches or hotfixes.
4. Ensure that the recommended HBA settings are applied.

## Storage Enclosure Management Installation — Windows

### Graphical Installation

1. Download the **Storage Enclosure Management Software** installation package from [dell.com/support](http://dell.com/support).
2. Navigate to the download directory of the installer.
3. Double click on the installation program, **StorageEnclosureManagement\_Install\_X.X.X.exe**.
4. Follow the on-screen instructions and accept the **End User License Agreement**.

 **NOTE:** Installation of the SNMP monitoring service is optional.

### Console Installation

1. Download the Storage Enclosure Management Software installation package from [dell.com/support](http://dell.com/support).
2. Run the command prompt as an **Administrator**.

 **NOTE:** The command prompt must be an Administrator prompt for proper use of the CLI.

3. Navigate to the download directory of the installer.
4. Execute the installer  
`StorageEnclosureManagment_Install_X.X.X.exe -i console`
5. Follow the on-screen instructions and accept the **End User License Agreement**.

 **NOTE:** Installation of the SNMP monitoring service is optional.

After successful installation, open an elevated command prompt and you will be able to run **secli** commands from the command prompt.

### Silent Installation

1. Download the Storage Enclosure Management Software installation package from [dell.com/support](http://dell.com/support).
2. Run the command prompt as an **Administrator**.

 **NOTE:** The command prompt must be an Administrator prompt for proper use of the CLI.

3. Navigate to the download directory of the extracted installer.
4. Run the installation program by running the command:  
`StorageEnclosureManagement_Install_X.X.X.exe -i silent`

This command installs the Storage Enclosure Management Software with all the default settings. The default installation directory is **C:\Program Files\Dell\ StorageEnclosureManagement**.

5. Accept all **End User License Agreements**.
6. To change the installation directory, uncomment and edit the following line in the **custom\_silent.properties** file:  
`#USER_INSTALL_DIR= C:\\Program Files\\Dell\\StorageEnclosureManagement`
7. To start the SNMP service upon installation, un-comment the following line in the properties file:  
`#SNMP_START=1`
8. Execute the command:  
`StorageEnclosureManagement_Install_X.X.X.exe -f  
<path_of_custom.properties_file>`

After successful installation, you can execute **secli** commands from the command prompt.

## Storage Enclosure Management Installation — Linux

### Graphical Installation

1. Download the **Storage Enclosure Management Software** installation package from **dell.com/support**.
2. Navigate to the download directory of the installer.
3. Double click on the installation program, **StorageEnclosureManagement\_Install\_X.X.X**.
4. Follow the on-screen instructions and accept the **End User License Agreement**.

 **NOTE:** You can choose to start the SNMP monitoring service once installation is complete.

### Console Installation

 **NOTE:** Linux installation requires full root user permissions.

 **NOTE:** The `libsnmp` package must be installed before installation.

1. Download the Storage Enclosure Management Software installation package from **dell.com/support**.
2. Navigate to the directory containing the extracted installer.
3. Execute the command:  
`./StorageEnclosureManagement_Install_X.X.X`
4. Follow the on screen directions and accept the **End User License Agreement**.

After successful installation, you will be able to execute **secli** commands from the console.

## Silent Installation



**NOTE:** Linux installation requires full root user permissions.

1. Download the Storage Enclosure Management Software installation package from **dell.com/support**.
2. Navigate to the directory containing the extracted installer.
3. Execute the command:

```
./StorageEnclosureManagement_Install_X.X.X -i silent
```

This command installs the Storage Enclosure Management Software with all the default settings. Accept all **End User License Agreements**. The default installation directory will be **/opt/Dell/StorageEnclosureManagement**.

4. To change the installation directory, uncomment and edit the following line in the **custom.properties** file:

```
#USER_INSTALL_DIR= /opt/dell/StorageEnclosureManagement
```

5. To start the SNMP daemon upon installation, uncomment the following line in the properties file:

```
#SNMP_START=1
```

6. Execute the command:

```
./StorageEnclosureManagement_Install_X.X.X -f  
<path_of_custom.properties_file>
```

After successful installation, you can execute **secli** commands from the terminal.

# Uninstalling the Storage Enclosure Management Software

## Windows

 NOTE: If the program was installed silently, the uninstallation is silent as well.

 NOTE: The **secli log** file will remain once the uninstallation is complete.

## Windows Explorer

1. Navigate to **Programs and Features** in the **Control Panel**.
2. Click the program **StorageEnclosureManagement**.
3. Click **Uninstall**.
4. Follow the onscreen instructions to complete the uninstallation.

## Command Prompt

1. Run the command prompt as an **Administrator**.
2. Navigate to the installation directory.  
The default directory is **C:\Program Files\Dell\StorageEnclosureManagement**.
3. Execute the uninstallation program, `Uninstall_StorageEnclosureManagement_X.X.X.exe`.

## Linux

 NOTE: Linux uninstallation requires full root user permissions.

 NOTE: If the program was installed silently, the uninstallation is silent as well.

 NOTE: The **secli** log file is not deleted from the system after uninstallation.

1. Navigate to the installation directory  
The default directory is: **/opt/Dell/StorageEnclosureManagement**
2. Execute the program:  
`./Uninstall_StorageEnclosureManagement_X.X.X`
3. Follow the onscreen instructions to complete the uninstallation.