

My CrossWave HF3 has no spray | Support

CrossWave HF3™ Cordless Multi-Surface Wet Dry Vac

If your CrossWave HF3 isn't releasing solution, follow these steps to resolve:

Fill clean water tank

- Turn machine OFF
- Remove clean water tank located on front of machine
 - Press button on top of tank > Pull out to remove

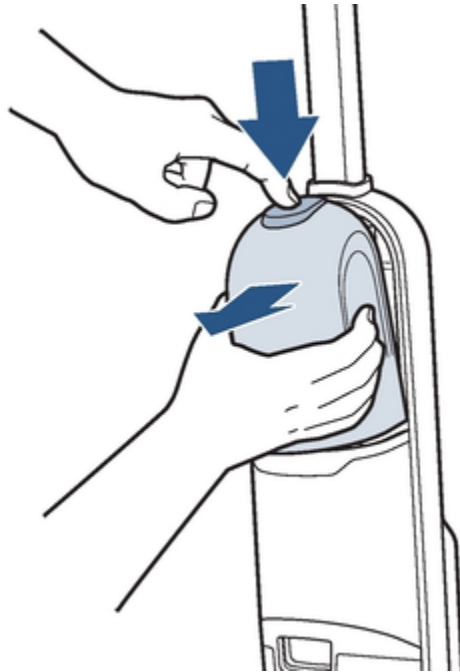

- Lift flap covering tank opening > Hold open
- Add warm water up to fill line on tank > Add BISSELL formula up to formula fill line

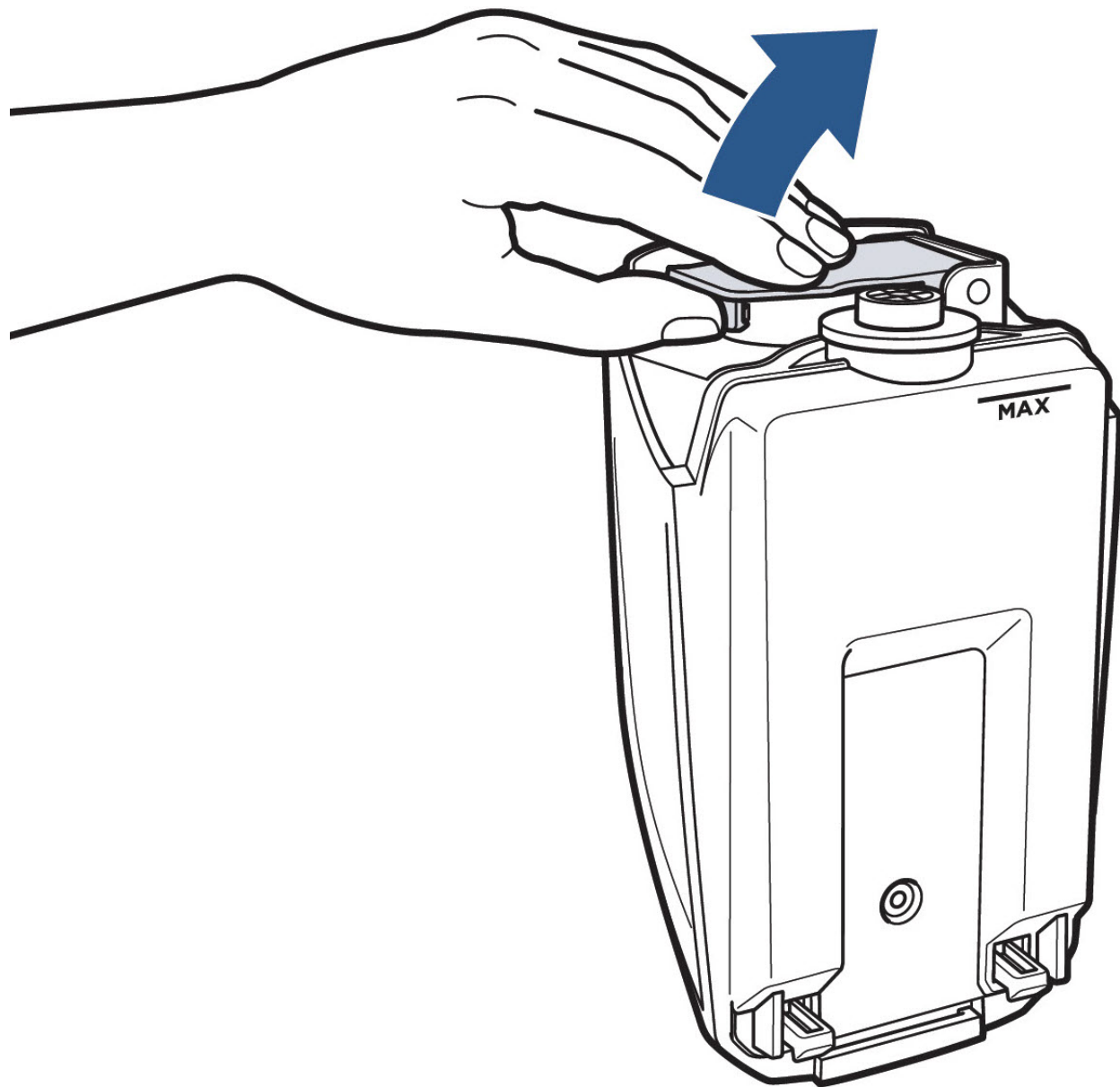

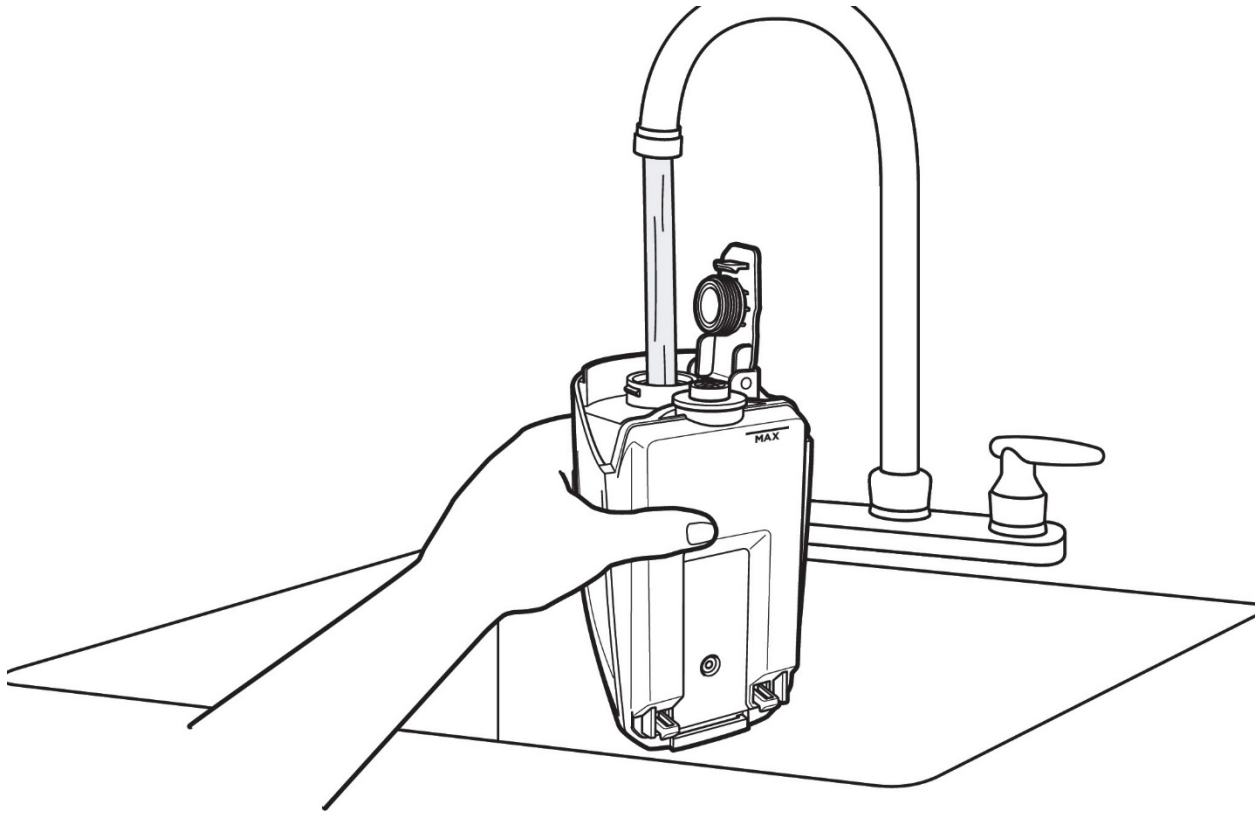

- Close tank flap
 - Ensure flap clicks when fully closed

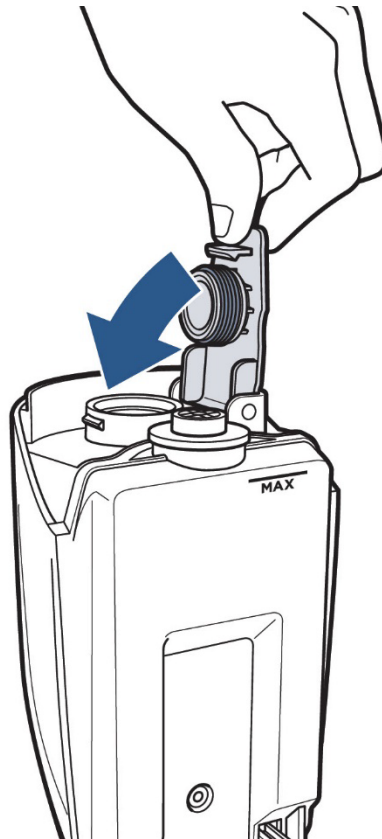

- Insert tank by:
 - Placing bottom of tank into machine
 - Pressing top of tank into machine until tank clicks into place
 - Ensure firmly seated with NO gaps



Test for spray

- Recline machine and turn ON > Machine defaults to LOW mode
- Change to HIGH spray mode
 - Press mode button
 - Ensure HIGH spray mode LED light is ON

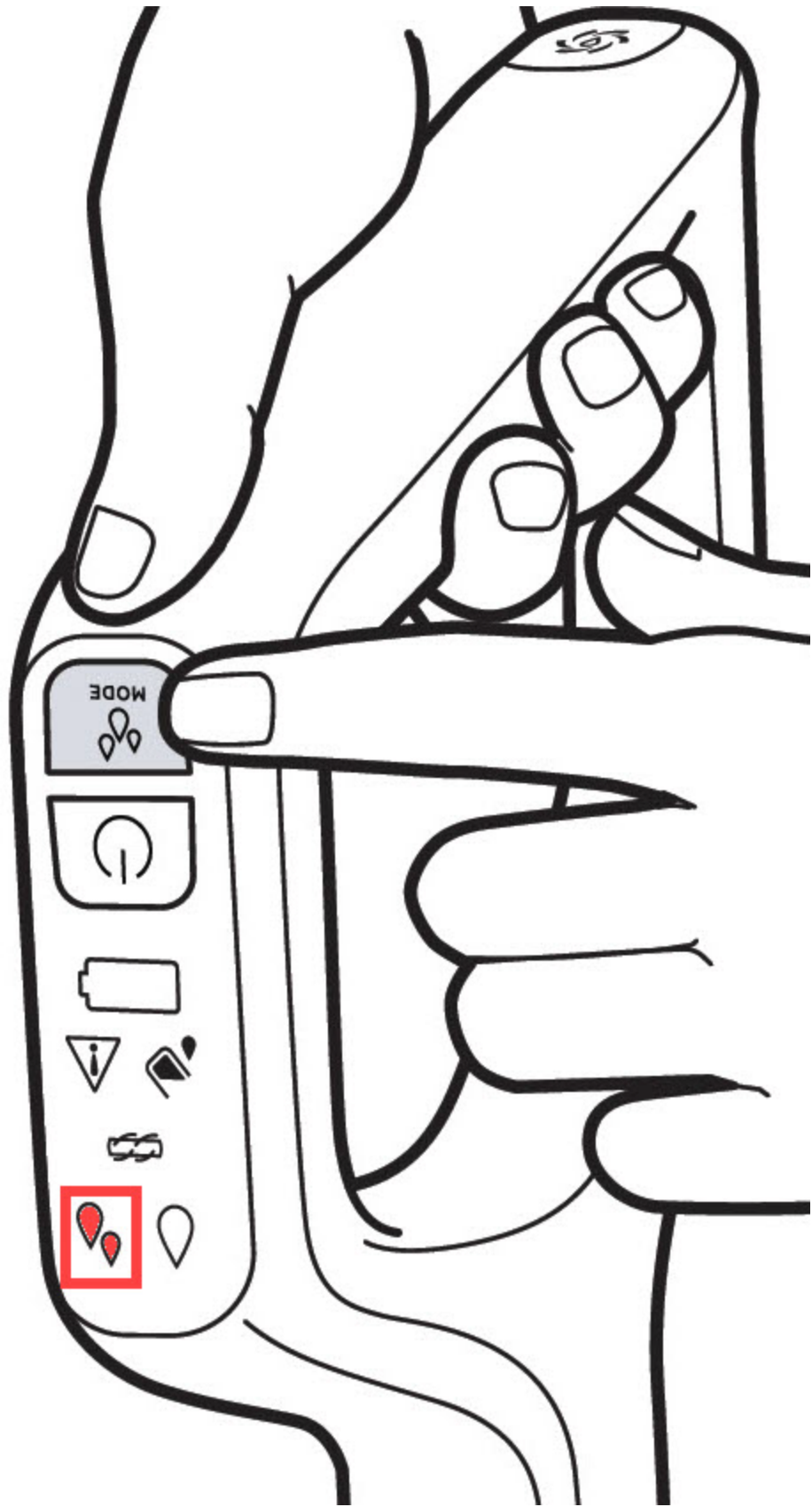

- Solution sprays automatically
- Make several test strokes on dry floor
 - Is there solution on floor?
 - Yes > Machine is spraying correctly
 - No > Continue to next step

Clean spray tip

- Turn machine OFF
- Remove brush roll cover > Pinch tabs and lift up

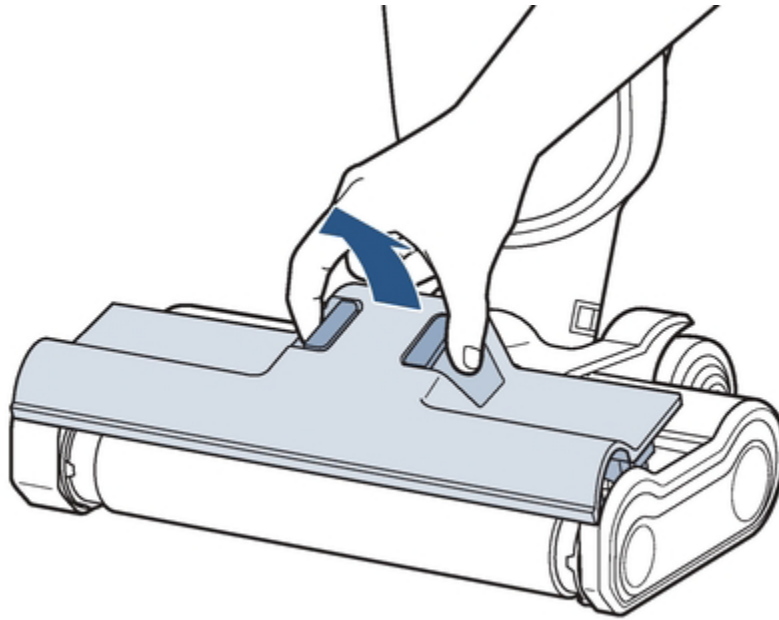

- Wipe spray tip with damp cloth
 - Located on left side of foot
 - Be sure to remove any product/mineral build up
- Use paper clip or toothpick to clean inside of spray tip
 - Remove any mineral build up

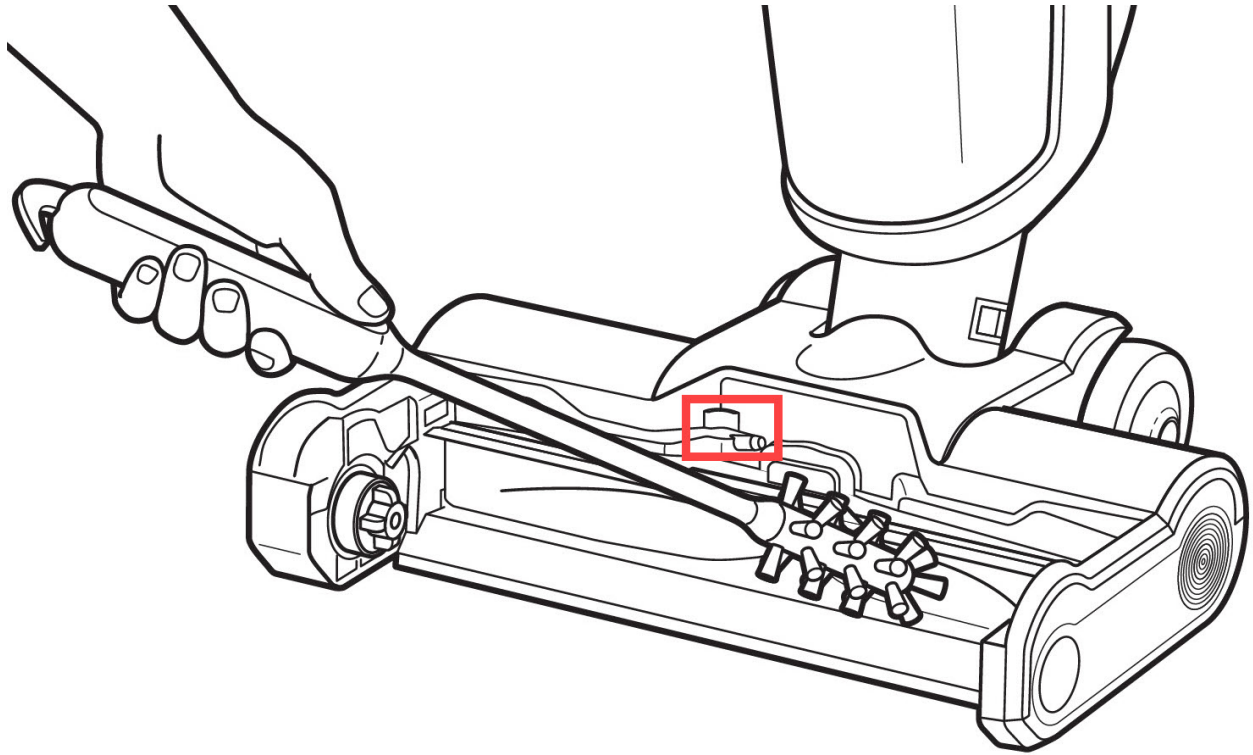

Reinstall parts

- Reinstall brush roll cover

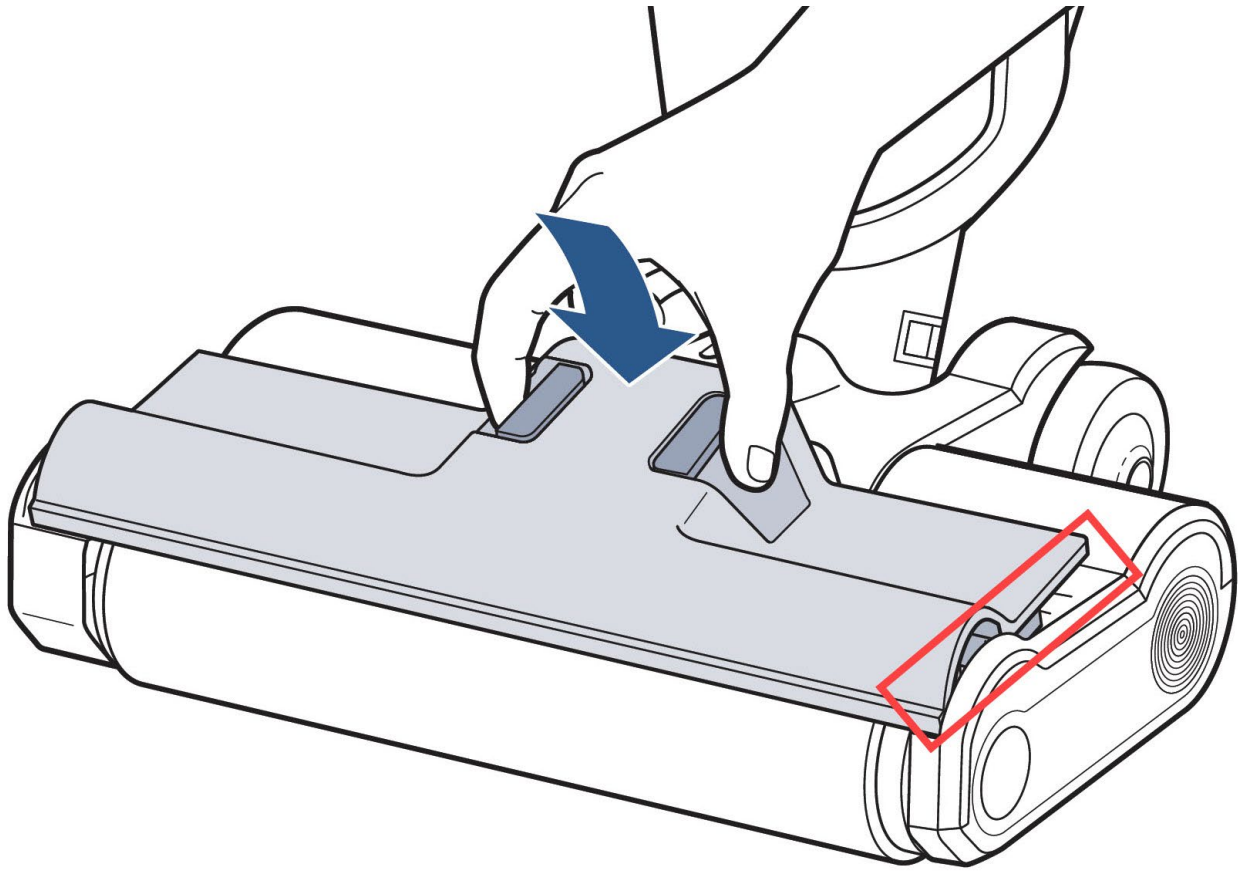

- Recline machine and turn ON > Make several test strokes on a dry floor
 - If brush roll is wet > Machine is spraying correctly

Did this resolve your issue?

- If you still need assistance > [Contact Us](#)