

Reverse Osmosis User Manual



HydrLogic[®]
PURIFICATION SYSTEMS

888-426-5644

info@hydrologicsystems.com

This page intentionally
left blank

TABLE OF CONTENTS

INTRODUCTION	5
SAFETY	6
PRECAUTIONARY STATEMENTS	6
COMPONENT IDENTIFICATION AND DESCRIPTION	7
CONTROLLER	8
PRE-FILTRATION	8
FEED PRESSURE GAUGE	9
LOW PRESSURE SWITCH	9
PUMP	9
PUMP PRESSURE GAUGE	9
MEMBRANES	9
CONCENTRATE (DRAIN) PRESSURE GAUGE	9
CONCENTRATE (DRAIN) FLOW METER	9
PRODUCT (PURIFIED WATER) FLOW METER	10
BLEND VALVE	10
SYSTEM INSTALLATION OVERVIEW	11
CHOOSING A LOCATION	11
FEED WATER CONNECTION	11
PRODUCT (PURIFIED WATER) CONNECTION	11
CONCENTRATE WATER (DRAIN) CONNECTION	11
ELECTRICAL	12
TANK	12
FEED WATER AND OPERATION SPECIFICATIONS	13
OPERATING LIMITS*	13
DESIGN BASIS AND DESIGN NOTES	14
SYSTEM PURGING / INITIAL START-UP	15
OPERATING DO'S AND DON'TS	17
MEMBRANE INSTALLATION, REMOVAL AND REPLACEMENT	18
MEMBRANE ELEMENTS	20
REJECTION, RECOVERY AND FLOW RATES	21
MEMBRANE PERFORMANCE	21
REJECTION	21
RECOVERY	21
TEMPERATURE CORRECTION FACTORS FOR MEMBRANES	22
OPERATING LOG	24
PREPARING UNIT FOR STORAGE OR SHIPMENT	25
PREPARING THE SYSTEM FOR STORAGE	25
PREPARING THE UNIT FOR SHIPMENT	25
TROUBLESHOOTING	26
TECHNICAL ASSISTANCE	26
S-100 CONTROLLER SPECIFICATIONS AND INSTRUCTIONS	27
INTRODUCTION	27
SPECIFICATIONS	27
FRONT PANEL CONTROLS AND INDICATORS	28
SYSTEM OPERATION	29
GENERAL OPERATION	29
DISPLAY AND STATUS INDICATORS	29
RO START DELAY	29
PRESSURE FAULT	29
PF AUTO RESET/PF RETRY	29
TANK FULL	30
PRE-TREAT LOCKOUT	30
WATER QUALITY DISPLAY	30
MEMBRANE FLUSH	30
WATER QUALITY SETPOINT	30
CALIBRATION	30

TROUBLESHOOTING.....	31
SYSTEM INOPERATIVE	31
INLET VALVE WILL NOT OPERATE.....	31
RO PUMP WILL NOT OPERATE.....	31
HYDROID FLOW DIAGRAM.....	32
ELECTRICAL WIRING DIAGRAM	33
SYSTEM WARRANTY	34

INTRODUCTION

The Hydroid Reverse Osmosis System is a state-of-the-art, versatile system for treating tap water supplies with minimal set-up, low energy consumption, low maintenance, and reduced operating costs. The Hydroid system features a robust, innovative design that requires no adjustments in the event of feed water quality or temperature variations. Your Hydroid system is a durable piece of equipment which, with proper care, will last for many years. Standard features include CONCENTRATE (drain) water recycle loop, PRODUCT (purified water) blend valve, PRODUCT (purified water) TDS monitoring, and preset pump, CONCENTRATE (drain) water and CONCENTRATE (drain) water recycle flows. Hydroid series systems feature high quality parts and components for enhanced performance and reliability including proprietary membrane elements, glycerin filled pressure gauges, acrylic flow meters, carbon pre-filter, Grundfos pump, 316SS needle valve, and computer controller.

This User Manual outlines installation, operation, maintenance and troubleshooting details vital for the sustained performance of your system.

PRIOR TO OPERATING OR SERVICING THE REVERSE OSMOSIS SYSTEM, THIS USER MANUAL MUST BE READ AND FULLY UNDERSTOOD. KEEP THIS AND OTHER ASSOCIATED INFORMATION NEAR THE SYSTEM FOR FUTURE REFERENCE.

IN ORDER TO MAINTAIN THE MANUFACTURER'S WARRANTY, AN OPERATING LOG MUST BE MAINTAINED. COPIES WILL NEED TO BE SENT TO HYDROLOGIC FOR REVIEW IN THE EVENT OF A WARRANTY COVERAGE ISSUE.

SAFETY

Defined below are the two safety headings used throughout this Users Manual's text.



WARNING: INDICATES STATEMENTS THAT ARE USED TO IDENTIFY DANGEROUS CONDITIONS OR PRACTICES. FAILURE TO FOLLOW WARNINGS COULD RESULT IN SERIOUS INJURY OR DEATH.



CAUTION: INDICATES STATEMENTS THAT ARE USED TO IDENTIFY CONDITIONS OR PRACTICES THAT COULD RESULT IN EQUIPMENT OR OTHER PROPERTY DAMAGE.

STATEMENTS IN BOLD AND ALL CAPITALS ARE ADVISORY OR INFORMATIONAL STATEMENTS OF PARTICULAR IMPORTANCE TO THE HEADING UNDER WHICH THEY ARE FOUND.

PRECAUTIONARY STATEMENTS



DO NOT USE WHERE THE WATER IS MICROBIOLOGICALLY UNSAFE OR OF UNKNOWN QUALITY WITHOUT ADEQUATE DISINFECTION BEFORE OR AFTER THE SYSTEM.



ALWAYS TURN OFF THE UNIT, SHUT OFF THE FEEDWATER, RELIEVE PRESSURE, AND DISCONNECT THE ELECTRICAL POWER BEFORE WORKING ON THE UNIT.



PRE-TREATMENT MUST BE SUFFICIENT TO ELIMINATE CHEMICALS, ORGANICS OR INORGANICS THAT COULD DAMAGE THE MEMBRANE MATERIAL.



DO NOT OPERATE THE SYSTEM WITH INSUFFICIENT FEED FLOW. NEVER ALLOW THE PUMP TO RUN DRY.



NEVER ALLOW THE UNIT TO FREEZE OR OPERATE WITH A FEEDWATER TEMPERATURE ABOVE 85°F.



DO NOT PERMIT CHLORINE TO BE PRESENT IN THE FEED WATER.



DO NOT SHUT DOWN THE SYSTEM FOR EXTENDED PERIODS. IT IS BEST TO RUN THE SYSTEM AS MUCH AS POSSIBLE ON A CONTINUOUS BASIS.

COMPONENT IDENTIFICATION AND DESCRIPTION

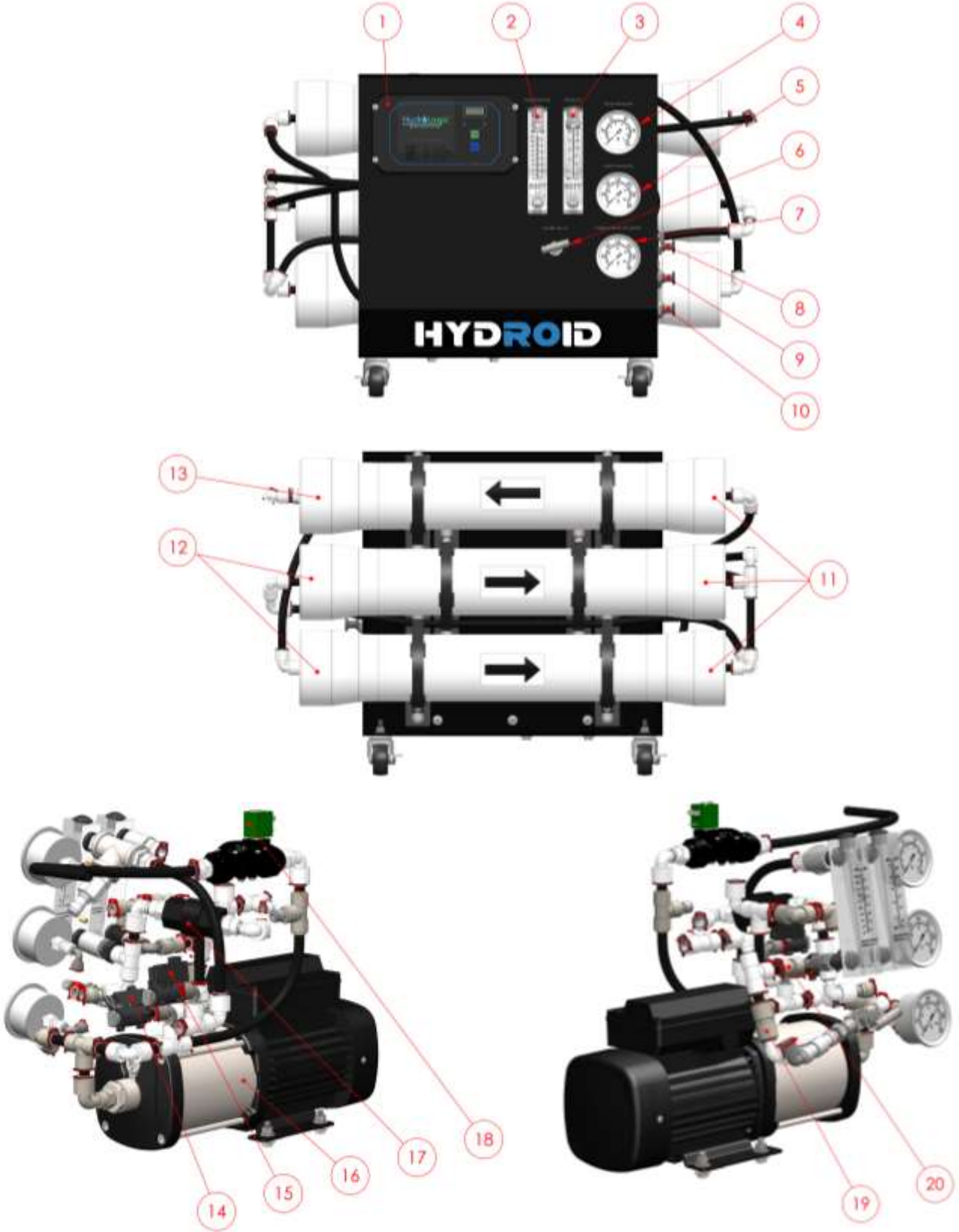

ITEM NUMBER	DESCRIPTION
1	CONTROLLER, COMPUTER, S-100, 110V, 1PH, W/TDS PROBE
2	METER, FLOW, 0.2-2 GPM, 1/2" MNPT X 1/4" FNPT CONCENTRATE (DRAIN)
3	METER, FLOW, 1-5 GPM, 1/2" MNPT X 1/4" FNPT PERMEATE (PURIFIED WATER)
4	GAUGE, PM, GLY FILL, 0-100 PSI/BAR, 2.5" DIA (FEED PRESSURE)
5	GAUGE, PM, GLY FILL, 0-300 PSI/BAR, 2.5" DIA (PUMP PRESSURE)
6	VALVE, NEEDLE, SS 316L, 1/4" FNPT (BLEND VALVE)
7	GAUGE, PM, GLY FILL, 0-300 PSI/BAR, 2.5" DIA (CONCENTRATE PRESSURE)
8	UNION, BULKHEAD, 1/2"QC X 1/2"QC, JG PRODUCT (PURIFIED WATER)
9	UNION, BULKHEAD, 1/2"QC X 1/2"QC, JG CONCENTRATE (DRAIN)
10	UNION, BULKHEAD, 1/2"QC X 1/2"QC, JG (FEED)
11	HOUSING, MEMBRANE, FRP-300E, 4021, 1/2"P X 1/2"C FNPT
12	MEMBRANE, HF5, 4021-820, HYDROLOGIC
13	CARTRIDGE, CARBON, GACC, 4" X 21", HYDROLOGIC
14	SWITCH, TANK, PRESSURE, 0-20 PSI, 3/8" QC (LOW PRESSURE SWITCH)
15	SWITCH, TANK, PRESSURE, 40-60 PSI, 3/8" QC (HIGH PRESSURE SWITCH)
16	PUMP, CM1-6, 1HP, 115/230V 60HZ 1PH, 10.6 AMPS 304SS, 98125766, GRUNDFOS
17	VALVE, CHECK, PP, GLASS FILLED, BLACK, 1/2" FNPT X 1/2" FNPT
18	VALVE, SOLENOID, 2-WAY, COMPOSITE, 120V, N/C, 1/2" FNPT, ASCO
19	CONNECTOR, FLOW CONTROL, 1/2"QC (RECYCLE FLOW RESTRICTOR)
20	CONNECTOR, FLOW CONTROL, 3/8"QC (CONCENTRATE (DRAIN) FLOW RESTRICTOR)

CONTROLLER

The Hydroid system comes standard with an S-100 Controller (Item 1). The S-100 series controller is a state-of-the-art, microprocessor-controlled system for commercial and industrial reverse osmosis systems. It includes numerous standard features such as pressure switch control, motor contactor, TDS/conductivity monitor with adjustable limit, pre-treatment lock out, tank level switch controls, and flush valve control. The controller displays system status and sensor on an easy-to-read LED display.



PRE-FILTRATION

Hydroid systems are supplied with a carbon pre-filter (Item 13). Change the pre-filter when a 10-15 psi differential exists between the incoming water supply pressure and "FEED" pressure (Pre-filter Out Pressure) on the system. For example, if the inlet pressure is 60 psi, the pre-filter should be changed when the FEED Pressure Gauge is 45-50 psi or below, and/or after capacity has been reached (75,000 gallons).



THE SYSTEM MUST BE OPERATED ON PRE-FILTERED WATER ONLY

FEED PRESSURE GAUGE

The feed pressure gauge (Item 4) measures the water pressure when it exits the pre-filter.

LOW PRESSURE SWITCH

The low-pressure switch (Item 14) shuts off the system when the feed water pressure drops below 15 psi, preventing damage to the pump. The system restarts automatically when there is a constant pressure of 35 psi or more.



IF THE SYSTEM PRESSURE IS FLUCTUATING, TURN THE SYSTEM OFF AND ENSURE THAT PROPER FEED WATER FLOW AND PRESSURE ARE BEING SUPPLIED TO THE SYSTEM.

PUMP

The Hydroid system uses a multi-stage centrifugal stainless-steel pump (Item 16). If any damage occurs to your system's pump, contact your local dealer or distributor and inform them of your system and pump model.



THE SYSTEM MUST BE OPERATED ON PRE-FILTERED WATER ONLY

PUMP PRESSURE GAUGE

The pump pressure gauge (Item 5) measures the pressure of the water as it enters the first membrane in the system.

MEMBRANES

The Hydroid system comes with two proprietary Hydroid Series HF5 Membrane Elements (Item 12). Membranes separate impurities from water through the reverse osmosis process. See Membrane Information and Handling section of this manual for additional information.

CONCENTRATE (DRAIN) PRESSURE GAUGE

The CONCENTRATE (drain) pressure gauge measures (Item 7) the pressure of the CONCENTRATE (drain water) as it exits the last Membrane of the system. Subtracting the CONCENTRATE (drain) pressure from the pump pressure will give the pressure drop across the Membrane array.

CONCENTRATE (DRAIN) FLOW METER

The CONCENTRATE (drain) flow meter (Item 2) measures the amount of wastewater the system is sending to drain as gallons/liters per minute.

PRODUCT (PURIFIED WATER) FLOW METER

The PRODUCT (purified water) flow meter (Item 3) measures the amount of PRODUCT (purified water) water the system is producing as gallons/liters per minute.



BLEND VALVE

The blend valve (Item 6) allows for a mixture of post-carbon treated water into the RO's PRODUCT (purified water) water to achieve desirable PRODUCT (purified water) TDS and higher flow rates.



IF THE SYSTEM HAS AN ANTI-SCALANT CARTRIDGE, THE BLEND VALVE MUST REMAIN CLOSED. THIS IS TO AVOID INGESTION OF ANY CHEMICALS AND CAN BE TOXIC FOR AGRICULTURAL USE. HL 11595

SYSTEM INSTALLATION OVERVIEW

Refer to page 15-18 for detailed instructions.

CHOOSING A LOCATION

When choosing a location to install the system, select an area with enough room to remove the membranes and easily access components and connections. Make sure there is enough room for service to be performed on the system. Take into consideration where your electrical power supply is located and where the nearest drain is located. Do not install system in direct sunlight, high intensity lights or subject the system to temperature extremes (see operating limits chart) and or excess humidity. The Hydroid system should be secured in compliance with state and local regulations.

FEED WATER CONNECTION

Locate the 1/2" Quick Disconnect fitting on the right side of the system labeled "FEED". Attach the inlet tubing to the system.



FEED LINE MUST BE 1/2 INCH (PROVIDED).



SYSTEM REQUIRES A CONTINUOUS FLOW OF WATER WITH A MINIMUM FEED PRESSURE OF 40 PSI, NOT TO EXCEED 85 PSI.

PRODUCT (PURIFIED WATER) CONNECTION

Locate the 1/2" Quick Disconnect fitting on the right side of the system labeled "PRODUCT (purified water)" and attach to storage tank. If you need more product tubing, contact your dealer.



ENSURE THAT THE PRODUCT (PURIFIED WATER) CAN FLOW FREELY WITH NO BACK PRESSURE. BACK PRESSURE CAN CAUSE IRREVERSABLE DAMAGE TO THE MEMBRANES.



THE PH OF THE REVERSE OSMOSIS PRODUCT (PURIFIED WATER) WATER WILL TYPICALLY BE 1 OR 2 PH UNITS LOWER THAN THE FEEDWATER PH. A LOW PH CAN DAMAGE SOME PLUMBING MATERIALS SUCH AS COPPER PIPING.

CONCENTRATE WATER (DRAIN) CONNECTION

Locate the 1/2" port on the right side of the system labeled "CONCENTRATE" (drain). Run the drain line to an open drain in a free and unrestricted manner (no back pressure).



ANY RESTRICTIONS OR BLOCKAGE IN THE DRAIN LINE CAN CAUSE BACK PRESSURE, WHICH WILL INCREASE THE SYSTEM'S OPERATING PRESSURE. THIS CAN RESULT IN DAMAGE TO THE SYSTEM'S MEMBRANES AND COMPONENTS.

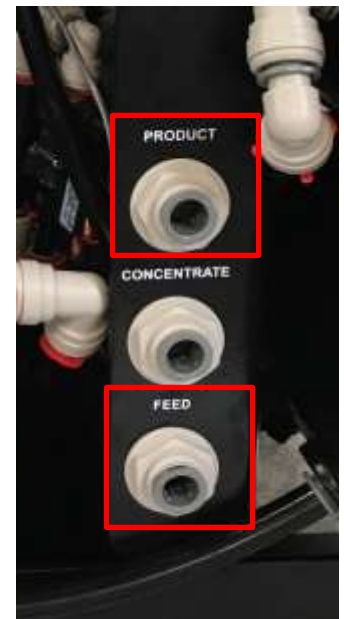

ELECTRICAL

The Hydroid system is 120 VAC 60 Hertz Single Phase, 10.6 amps, and is equipped with an eight-foot electrical cord.

Ensure that the electrical circuit supplying the system is compatible with the requirements of the Hydroid.



TO REDUCE THE RISK OF ELECTRICAL SHOCK, THE INCOMING POWER SUPPLY MUST INCLUDE A PROTECTIVE EARTH GROUND.



IT'S RECOMMENDED THAT THE SYSTEM HAVE A DEDICATED POWER SOURCE

TANK

Hydroid systems may be connected to a bladder tank or a storage tank with a float valve. The float valve shuts off the system when the tank is full and opens when the water level in the tank drops. Bladder tanks and storage tanks with float valves can be obtained by your local dealer or distributor. If a storage tank with float valve is to be used, install it at this time.



THE SYSTEM MUST BE OPERATED ON PRE-FILTERED WATER ONLY.

FEED WATER AND OPERATION SPECIFICATIONS

Nothing has a greater effect on a reverse osmosis system than the feed water quality. If your system is altered at the site of operation or if the feed water conditions change, please contact Hydrologic. Before starting the RO system, it is strongly suggested to obtain an up to date water analysis of the water to be treated.



IT IS VERY IMPORTANT TO MEET THE MINIMUM FEED WATER AND OPERATING REQUIREMENTS OUTLINED IN THIS MANUAL. FAILURE TO DO SO WILL CAUSE DAMAGE OR FAILURE OF THE SYSTEM COMPONENTS AND MEMBRANES. DAMAGE TO THE SYSTEM DUE TO OPERATION OUTSIDE OF THE SPECIFICATIONS OUTLINED IN THIS MANUAL WILL VOID THE MANUFACTURERS WARRANTY. CHECK YOUR FEED WATER CHEMISTRY AND, IF NECESSARY, CONSULT WITH HYDROLOGIC BEFORE START UP OF THE SYSTEM.

OPERATING LIMITS*

Design Temperature, °F	77	Maximum Turbidity, NTU	1
Maximum Feed Temperature, °F	85	Maximum Free Chlorine, ppm	0
Minimum Temperature, °F	40 [†]	Maximum TDS, ppm	2,000 [†]
Maximum Ambient Temperature, °F	120	Maximum Hardness, gpg	1
Minimum Ambient Temperature, °F	40	Maximum PH (continuous)	10
Maximum Feed Pressure, PSI	85	Minimum PH (continuous)	4
Minimum Feed Pressure, PSI	40	Maximum PH (cleaning 30 minutes)	12
Maximum Operating Pressure, PSI	150	Minimum PH (cleaning 30 minutes)	2
Maximum SDI Rating	<3		

*If any of the feed water parameters are not within the limits given, consult your local dealer or distributor for assistance.

[†] Low temperatures and feedwater quality, such as high TDS levels will significantly affect the systems production capabilities and performance. Computer projections must be run for individual applications which do not meet or exceed minimum and maximum operating limits for such conditions.



HIGHER TDS AND/OR LOWER TEMPERATURES WILL REDUCE THE SYSTEM'S PRODUCTION.

DESIGN BASIS AND DESIGN NOTES

Design	
Configuration	Single Pass
Feedwater Source	TDS < 2000
System Recovery with Recycle	66+% ††
System Pressure	100 PSI †††
Rejection and Flow Rates†††	
Nominal Salt Rejection	95%
PRODUCT (purified water) Flow Rate	2.08+ GPM ††
CONCENTRATE (drain) Flow Rate	0.80 GPM
CONCENTRATE (drain) Recycle Flow Rate	2.20 GPM
Connections	
Feed Connection	1/2" QC
PRODUCT (purified water) Connection	1/2" QC
CONCENTRATE (drain) Connection	1/2" QC
Carbon Cartridge	
Cartridge Quantity	1
Cartridge Size	4021
Membranes	
Membranes Per Vessel	1
Membrane Quantity	2
Membrane Size	4021
Vessels	
Vessel Array	1:1
Vessel Quantity	2
Pumps	
Pump Type	Multi-Stage
Motor HP	1
RPM at 60HZ	3450
System Electrical	
Controller	S100
High Voltage Service + Amp Draw	120V 1PH 60 HZ ,10.6A
System Dimensions	
Approximate Dimensions †††† (L x W X H)	29.5" X 18.5" X 18"
Approximate Weight (Wet System)	145 lbs.

††PRODUCT (purified water) flow and maximum recovery rates are based on feedwater conditions as stated above. Do not exceed recommended PRODUCT (purified water) flow.

†††System Pressure is variable due to water conditions. PRODUCT (purified water) flow will increase at a higher temperature and decrease at a lower temperature.

††††Does not include operating space requirements.

SYSTEM PURGING / INITIAL START-UP

LEAVE THE SYSTEM UNPLUGGED FROM POWER UNTIL STEP 6

1. Remove the dust caps and short tubes from all ports: PRODUCT (purified water - blue tubing), CONCENTRATE (drain - black tubing), and FEED (inlet - white tubing). Install the provided white tubing to FEED port for inlet water. Install a red clip (included in system parts bag) on FEED port to lock tubing in place. Install other end of white FEED line to tap/source water, or use included garden hose connector (included in system parts bag).



Refer to page 19, step 3 for quick-release port instructions.

2. The open end of the pre-installed $\frac{1}{2}$ " black tubing labeled "Flush" (B) goes to a drain. Now you can begin to slowly turn on the water supply and flush the dust from the carbon pre-filter, until water stream is clear (approx. 5 min).
3. Turn OFF the water supply and immediately turn it ON again, to create an agitated flush effect in the carbon cartridge. Repeat this process 3 – 4 times or until there are no carbon fines in the water stream.
4. **Re-install System Tubing for Normal Operation:** Remove red clip (A), disconnect $\frac{1}{2}$ " black Flush tubing (B) and then push system tubing (C) into carbon pre-filter port. Replace the red clip to lock system tubing to carbon pre-filter, shown in the picture below. **IMPORTANT: Keep Black Flush Tubing for future carbon pre-filter flush procedures.**

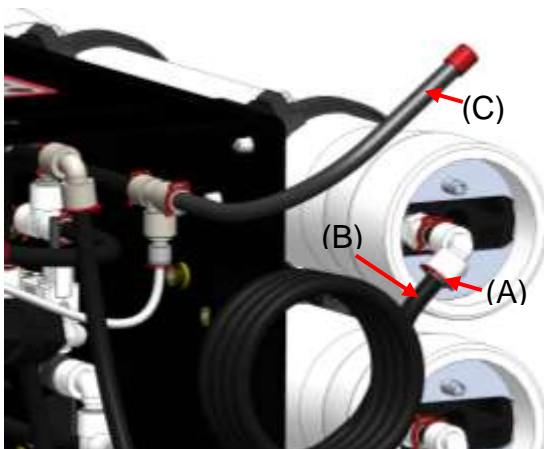

1. Remove Red Clip (A)
2. Disconnect Flush Tubing (B)
3. Insert System Tubing (C)
4. Replace Red Clip (A)

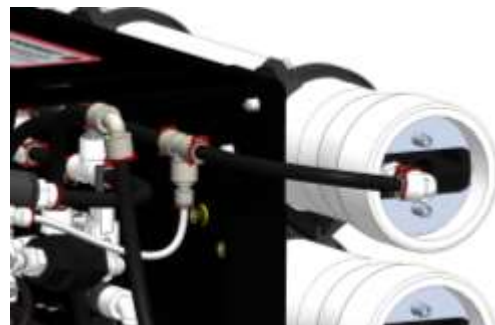

5. **Connect Provided Tubing:** PRODUCT (purified water - blue tubing) and CONCENTRATE (drain - black tubing) to their ports; re-direct the open ends of both the PRODUCT (purified water – blue tubing) and CONCENTRATE (waste water – black tubing) to drain. Install the red clips included in systems parts bag. Fully close the blend valve by turning it clockwise.

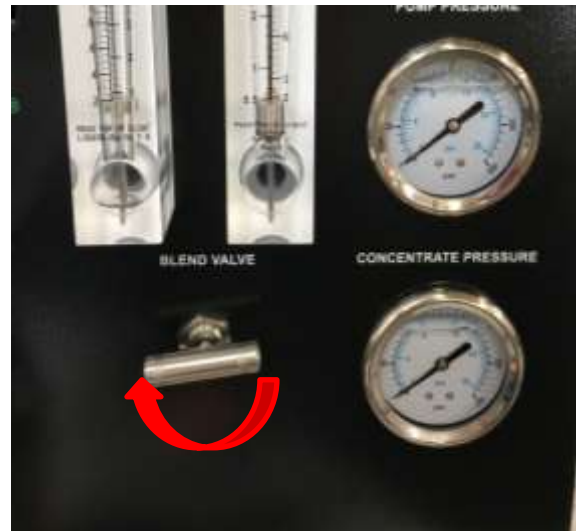
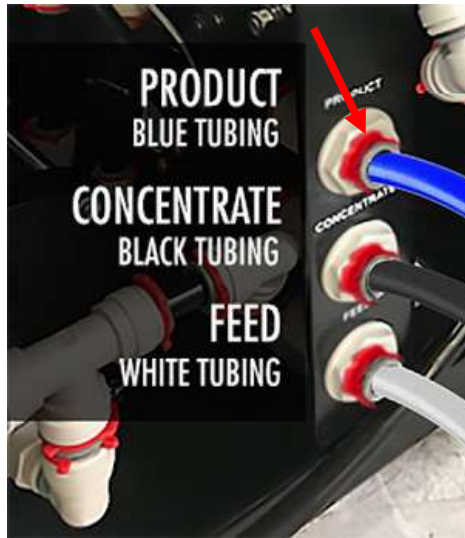

6. Activate the system purge feature by pressing and holding the Power button on the controller for 5 seconds. The inlet valve will open and the system will flush continuously.
7. Let the system purge until no bubbles appear in CONCENTRATE (drain water - black tubing) flow meter (approx. 3-5 min).
8. When the Hydroid system has been purged of air, press the power button momentarily to turn off the purge feature. The inlet valve will now turn off.
9. Inspect the system for leaks. If no leaks are apparent, the next step is to flush the Membrane Elements.
10. Turn system on and allow the system to run uninterrupted for at least 30 minutes to flush the Membrane Elements.
11. After 30 minutes, shut down the system and re-direct PRODUCT (purified water - blue tubing) to holding tank. Your system is now ready for normal operation.



Scan this code to bring up
[www.hydrologicsystems.com/
collections/reverse-osmosis/
products/hydroid](http://www.hydrologicsystems.com/collections/reverse-osmosis/products/hydroid)

Click "VIDEOS" for installation instructions

OPERATING DO'S AND DON'TS

DO

- Change the carbon pre-filter regularly.
- Monitor the system and keep a regular log.
- Run the system at least every 48 hours for one hour or more.
- Always feed the pump with pre-filtered water.



DON'T

- Permit chlorine to enter the feed water (change carbon pre-filter every 75,000 gallons).
- Shut down the system for extended periods (see manual page 25).
- Operate the system with insufficient feed flow or pressure.
- Operate the pump dry.



TO MAINTAIN PROPER PRESSURE, MAXIMUM HORIZONTAL TUBING DISTANCE TO TANK STORAGE IS 50FT. IMPORTANT! FOR EVERY 5FT VERTICAL HEIGHT, YOU NEED TO SHORTEN TUBING BY 10FT OF HORIZONTAL LENGTH. EXAMPLE: IF TUBING NEEDS TO BE INSTALLED 10FT OFF THE GROUND, TOTAL HORIZONTAL LENGTH MAY NOT EXCEED 30FT. IF LENGTH EXCEEDS SPECIFICATIONS, PLEASE CONTACT HYDROLOGIC 888-426-5644



USING THE REVERSE OSMOSIS SYSTEM OPERATION LOG PROVIDED ON PAGE 24 OF THE USER MANUAL, RECORD YOUR SYSTEM'S READING DAILY FOR A WEEK. AFTER A WEEK, RECORD THE READINGS AT A MINIMUM OF ONCE A WEEK. IT IS SUGGESTED TO MAKE SEVERAL COPIES OF THIS SHEET FOR FUTURE USE BEFORE RECORDING INITIAL READINGS. KEEPING AN OPERATION LOG IS IMPORTANT TO TROUBLESHOOT POSSIBLE TECHNICAL ISSUES.



IF THE SYSTEM HAS AN ANTI-SCALANT CARTRIDGE (OPTIONAL HL 11595), AND IF THE PRODUCT (PURIFIED WATER) WATER IS USED AS POTABLE WATER, THE BLEND VALVE MUST REMAIN CLOSED. THIS IS TO AVOID INGESTION OF ANY CHEMICALS.

MEMBRANE INSTALLATION, REMOVAL AND REPLACEMENT

Installation and replacing membranes are an easy process if you have the proper information at hand. Please refer to the following instructions when removing and replacing membrane elements:



ALL PRESSURE GAUGES MUST READ ZERO BEFORE BEGINNING THIS PROCEDURE. TURN THE SYSTEM OFF, DISCONNECT THE POWER, AND BLEED ALL WATER PRESSURE FROM THE SYSTEM



THE BRINE SEAL MUST BE IN THE CORRECT POSITION FOR EACH MEMBRANE HOUSING IN ORDER FOR THE MEMBRANE TO FUNCTION CORRECTLY.

Pay close attention to the flow direction arrows on the membrane housings when installing new membranes.

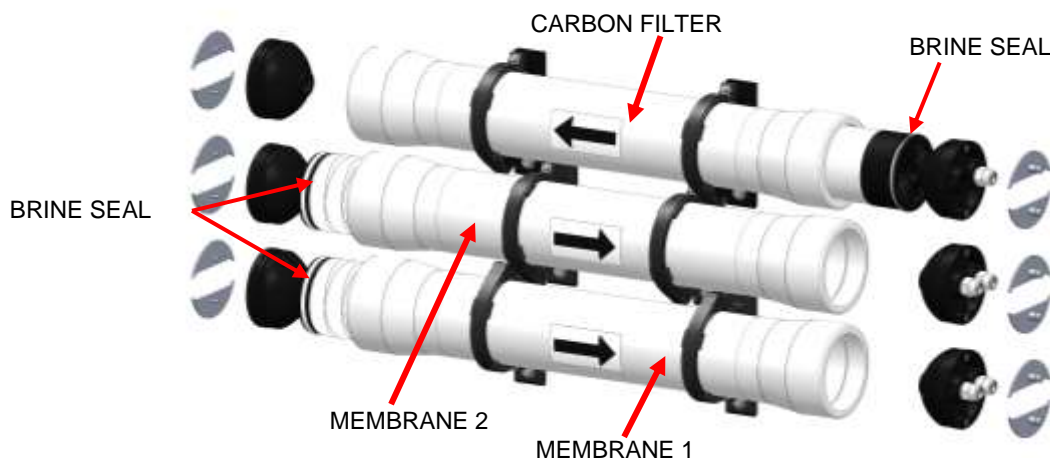

WEAR GLOVES FOR THE FOLLOWING STEPS IN ORDER NOT TO CONTAMINATE THE MEMBRANE.

- 1) Perform this procedure one housing at a time to preserve the correct connections as you replace the membranes (To remove Membrane 2, Carbon pre-filter must be removed first).
- 2) Select the housing to be replaced.
- 3) Disconnect the fittings from the housing by simultaneously:
 - a) Pushing the grey collar toward the housing.
 - b) Pulling the tube from the collar.
- 4) Remove the screw from the clamp and twist the top clamp to un-hook the clamp.
- 5) Unscrew and remove the two locking crescents using a #5 Hex wrench. To remove the end plugs, use a 1/2" NPT male threaded PVC (or similar material) pipe. Thread the tee to the nipple then into the end plug permeate port to hand tightness. Pull the pipe outward to remove the end plug. If the pressure vessel has been in operation for an

extended time, a slight rocking motion or forceful tug may be required. Set the end plug aside in a clean area where the O-ring will not pick up dirt or debris.

- 6) Remove the membrane bag containing the membrane element from the shipping box.



- 7) Cut the bag open as close as possible to the seal at the end of the bag, so the bag may be re-used if necessary.
- 8) Make sure that all parts are clean and free from dirt. Examine the brine seal and permeate tube for nicks or cuts. Replace the O-rings or brine seal if damaged.
- 9) Remove the old membranes from the pressure vessels. Long nose pliers may be necessary to pull the old membrane out of the pressure vessel.
- 10) Lubricate the brine seal and O-rings on the new membranes with a non-petroleum-based lubricant, such as Dow Corning® 111. Do not use a petroleum-based lubricant.
- 11) Apply the same lubricant to the inside of the pressure vessel below the groove for the locking crescents, where the membrane brine seal will make contact when inserted.
- 12) Install membranes with brine seal location depicted in the membrane flow chart on the previous page.
- 13) The membrane should stop when fully seated in the bottom end plug.
- 14) Reassemble the top end plugs.



MAKE SURE THE O-RINGS AND END PLUGS ARE FREE FROM DIRT AND DEBRIS BEFORE RE-INSTALLING. DIRT AND OTHER FOREIGN MATERIALS LEFT ON THE END PLUGS CAN CAUSE LEAKS AND/OR DAMAGE THE MEMBRANES AND CAUSE CONTAMINATION.

- 15) Re-install the end plugs by gently and evenly pushing them onto the pressure vessel. Ensure that you do not pinch or fatigue any o-rings while re-installing the end plug. Push the end plug in until it is seated just below the groove for the locking crescents.
- 16) Reinstall the locking crescents and securely tighten the screws.
- 17) Reconnect any fittings that may have been disconnected when the pressure vessels were disassembled.
- 18) To start-up the system, please refer to the System Purging/Initial Start-Up section of this User's Manual.



THE MEMBRANES MUST BE FLUSHED FOR AT LEAST 30 MINUTES. DISCARD ALL OF THE PRODUCT (PURIFIED WATER) THAT IS PRODUCED DURING THE FLUSH PERIOD.

MEMBRANE ELEMENTS

Hydroid Reverse Osmosis Systems are equipped with Hydroid Series HF5 Membrane Elements with Ultra Low Energy Membranes. Membrane Element performance characteristics are listed below.

ULTRA LOW ENERGY MEMBRANE

- **Membrane Type:** Polyamide Thin – Film Composite
- Maximum Operating Temperature: 85°F (43°C)
- Maximum Operating Pressure: 150 psi (10 bar)
- pH Range, Continuous Operation*: 2 – 11
- pH Range, Short Term Cleaning (30 Min.): 1 – 13
- Maximum Feed Silt Density Index (SDI): ≤3
- Chlorine Tolerance: 0 ppm
- Maximum Feed Flow Rate (gpm): 4.0" = 5

*Maximum temperature for continuous operations above pH10 is 95°F (35°C)

Product Specifications				
Part Number	Description	Applied Pressure psi / bar	PRODUCT Flow Rate gpd / m3/d	Nominal Salt Rejection (%)
HL 11590	MEMBRANE	100 / 5.52	1000 / 3.79	96

Warranty Evaluation Test Conditions: PRODUCT (purified water) flow and salt rejection based on the following test conditions – 550 ppm, filtered and dechlorinated municipal tap water, 77°F / 25°C, 15% recovery and the specified operating pressure. Minimum salt rejection is 96%+. PRODUCT (purified water) flows for warranty evaluation may vary +/-20%. Maximum pressure drops at 13 psi / 0.9 bar.

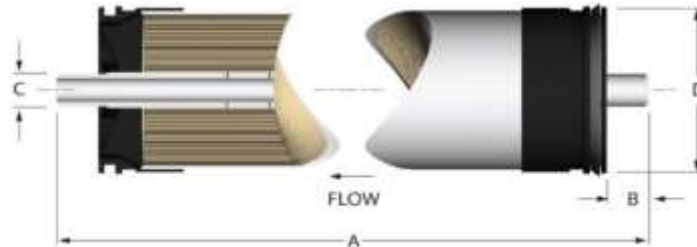

Under certain conditions, the presence of free chlorine, chloramines and other oxidizing agents will cause premature membrane failure. Since oxidation damage is not covered under warranty, the manufacturer recommends removing all oxidizing agents by pretreatment prior to membrane exposure. Please contact the manufacturer or your supplier for more information.

Do not use the initial PRODUCT (purified water) for drinking water or food preparation. Keep elements moist at all times after initial wetting. To prevent biological growth during prolonged system shutdowns, it is recommended that membrane elements be immersed in a preservative solution. Rinse out the preservative before use. For membrane warranty details, contact the manufacturer or your supplier for more information.

If operating limits and guidelines given in this PRODUCT (purified water) specification sheet are not strictly followed, the warranty will be null and void. The customer is fully responsible for the effects of incompatible chemicals and lubricants on elements. Use of any such chemicals or lubricants will void the warranty. These membranes may be subject to drinking water application restrictions in some countries: check the application status before use and sale. The use of this PRODUCT (purified water) in and of itself does not guarantee the removal of cysts and pathogens from water. Effective cyst and pathogen reduction are dependent on the complete system (solution) design and the operation and maintenance of the system.

No freedom from infringement of any patent owned by the manufacturer or others is to be inferred. Because use conditions and applicable laws may differ from one location to another and may change with time, Customer is responsible for determining whether PRODUCT (purified water) and the information in this document are appropriate for customer's use and for ensuring that customer's workplace and disposal practices are in compliance with applicable laws and other governmental enactments. The claims made may not have been approved for use in all countries. The manufacturer assumes no obligation or liability for the information in this document. HYDROLOGIC RESERVES THE RIGHT TO UPDATE THIS INFORMATION PERIODICALLY FOR THE PURPOSE OF QUALITY AND ACCURACY. NO WARRANTIES ARE GIVEN; ALL IMPLIED WARRANTIES OF MERCHANTABILITY OR FITNESS FOR A PARTICULAR PURPOSE ARE EXPRESSLY EXCLUDED.

REJECTION, RECOVERY AND FLOW RATES

MEMBRANE PERFORMANCE

Hydroid reverse osmosis systems are designed to produce 3000 GPD* of PRODUCT (purified water) water at a minimum of 95%+ rejection under the proper conditions.

REJECTION

The amount of total dissolved solids (TDS) rejected by the membrane is expressed as a percentage. Hydroid reverse osmosis systems are designed to reject up to 96%+ NaCl depending on feed water chemistry. A 96%+ rejection rate means that 96% of total dissolved solids do not pass through the membrane. To calculate the percent of rejection, use the following formula:

$$\% \text{ REJECTION} = \frac{\text{FEED TDS} - \text{PERMEATE TDS}}{\text{FEED TDS}} \times 100$$

Example:

$$\frac{550 \text{ TDS} - 8.25 \text{ TDS}}{550 \text{ TDS}} \times 100 = 98.5\% \text{ REJECTION}$$

RECOVERY

The amount of PRODUCT (purified water) water recovered for use is expressed as a percentage. To calculate percent of recovery, use the following formula:

$$\% \text{ RECOVERY} = \frac{\text{PRODUCT WATER FLOW RATE}}{\text{FEEDWATER FLOW RATE}} \times 100$$

Example:

$$\frac{6.5 \text{ GPM}}{9.5 \text{ GPM}} \times 100 = 68\% \text{ RECOVERY}$$



ALL FLOW RATES MUST BE EXPRESSED IN THE SAME UNITS, TYPICALLY GALLONS PER MINUTE (GPM).

Observe that the PRODUCT (purified water) flow meter does not exceed 2.08+ GPM based on the table below.

PSI	% Rejection	PRODUCT (purified water) Flow (GPD)	PRODUCT (purified water) Flow (GPM)
100	96.00%+	3000	2.08+

TEMPERATURE CORRECTION FACTORS FOR MEMBRANES

A membrane's stated PRODUCT (purified water) production rate is based on a water temperature of 77°F. Temperature above or below 77°F will increase or decrease the membrane's production rate.

Find the temperature correction factor (TCF) for your water temperature on the table located on the next page. Divide the rated PRODUCT (purified water) flow (This can be found on the System Specification Chart on Page of this manual under the maximum PRODUCT (purified water) flow rate category) by the temperature correction factor. The result is the nominal PRODUCT (purified water) flow rate the system should achieve at actual water temperature. PRODUCT (purified water) flow should be within 20% of the rated production, after correcting the feed water temperatures above or below 77°F. Check your PRODUCT (purified water) flow meter to determine the flow rate.

Example:

$$5 \text{ GPM at } 59^\circ\text{F} \rightarrow \frac{5 \text{ GPM}}{1.42} = 3.52 \text{ GPM}$$

$$5 \text{ GPM at } 77^\circ\text{F} \rightarrow \frac{5 \text{ GPM}}{1} = 5 \text{ GPM}$$

$$5 \text{ GPM at } 84^\circ\text{F} \rightarrow \frac{5 \text{ GPM}}{0.89} = 5.62 \text{ GPM}$$

Find the temperature correction factor (TCF) from the table below. Divide the rated PRODUCT (purified water) flow at 77°F by the temperature correction factor. The result is the PRODUCT (purified water) flow at the desired temperature.

Temperature °F (°C)	Temperature Correction Factor	Temperature °F (°C)	Temperature Correction Factor	Temperature °F (°C)	Temperature Correction Factor	Temperature °F (°C)	Temperature Correction Factor	Temperature °F (°C)	Temperature Correction Factor
50.0 (10.0)	1.711	57.2 (14.0)	1.475	64.4 (18.0)	1.276	71.6 (22.0)	1.109	78.8 (26.0)	0.971
50.2 (10.1)	1.705	57.4 (14.1)	1.469	64.6 (18.1)	1.272	71.8 (22.1)	1.105	79.0 (26.1)	0.968
50.4 (10.2)	1.698	57.6 (14.2)	1.464	64.8 (18.2)	1.267	72.0 (22.2)	1.101	79.2 (26.2)	0.965
50.5 (10.3)	1.692	57.7 (14.3)	1.459	64.9 (18.3)	1.262	72.1 (22.3)	1.097	79.3 (26.3)	0.962
50.7 (10.4)	1.686	57.9 (14.4)	1.453	65.1 (18.4)	1.258	72.3 (22.4)	1.093	79.5 (26.4)	0.959
50.9 (10.5)	1.679	58.1 (14.5)	1.448	65.3 (18.5)	1.254	72.5 (22.5)	1.090	79.7 (26.5)	0.957
51.1 (10.6)	1.673	58.3 (14.6)	1.443	65.5 (18.6)	1.249	72.7 (22.6)	1.086	79.9 (26.6)	0.954
51.3 (10.7)	1.667	58.5 (14.7)	1.437	65.7 (18.7)	1.245	72.9 (22.7)	1.082	80.1 (26.7)	0.951
51.4 (10.8)	1.660	58.6 (14.8)	1.432	65.8 (18.8)	1.240	73.0 (22.8)	1.078	80.2 (26.8)	0.948
51.6 (10.9)	1.654	58.8 (14.9)	1.427	66.0 (18.9)	1.236	73.2 (22.9)	1.075	80.4 (26.9)	0.945
51.8 (11.0)	1.648	59.0 (15.0)	1.422	66.2 (19.0)	1.232	73.4 (23.0)	1.071	80.6 (27.0)	0.943
52.0 (11.1)	1.642	59.2 (15.1)	1.417	66.4 (19.1)	1.227	73.6 (23.1)	1.067	80.8 (27.1)	0.940
52.2 (11.2)	1.636	59.4 (15.2)	1.411	66.6 (19.2)	1.223	73.8 (23.2)	1.064	81.0 (27.2)	0.937
52.3 (11.3)	1.630	59.5 (15.3)	1.406	66.7 (19.3)	1.219	73.9 (23.3)	1.060	81.1 (27.3)	0.934
52.5 (11.4)	1.624	59.7 (15.4)	1.401	66.9 (19.4)	1.214	74.1 (23.4)	1.056	81.3 (27.4)	0.932
52.7 (11.5)	1.618	59.9 (15.5)	1.396	67.1 (19.5)	1.210	74.3 (23.5)	1.053	81.5 (27.5)	0.929
52.9 (11.6)	1.611	60.1 (15.6)	1.391	67.3 (19.6)	1.206	74.5 (23.6)	1.049	81.7 (27.6)	0.926
53.1 (11.7)	1.605	60.3 (15.7)	1.386	67.5 (19.7)	1.201	74.7 (23.7)	1.045	81.9 (27.7)	0.924
53.2 (11.8)	1.600	60.4 (15.8)	1.381	67.6 (19.8)	1.197	74.8 (23.8)	1.042	82.0 (27.8)	0.921
53.4 (11.9)	1.594	60.6 (15.9)	1.376	67.8 (19.9)	1.193	75.0 (23.9)	1.038	82.2 (27.9)	0.918
53.6 (12.0)	1.588	60.8 (16.0)	1.371	68.0 (20.0)	1.189	75.2 (24.0)	1.035	82.4 (28.0)	0.915
53.8 (12.1)	1.582	61.0 (16.1)	1.366	68.2 (20.1)	1.185	75.4 (24.1)	1.031	82.6 (28.1)	0.913
54.0 (12.2)	1.576	61.2 (16.2)	1.361	68.4 (20.2)	1.180	75.6 (24.2)	1.028	82.8 (28.2)	0.910
54.1 (12.3)	1.570	61.3 (16.3)	1.356	68.5 (20.3)	1.176	75.7 (24.3)	1.024	82.9 (28.3)	0.908
54.3 (12.4)	1.564	61.5 (16.4)	1.351	68.7 (20.4)	1.172	75.9 (24.4)	1.021	83.1 (28.4)	0.905
54.5 (12.5)	1.558	61.7 (16.5)	1.347	68.9 (20.5)	1.168	76.1 (24.5)	1.017	83.3 (28.5)	0.902
54.7 (12.6)	1.553	61.9 (16.6)	1.342	69.1 (20.6)	1.164	76.3 (24.6)	1.014	83.5 (28.6)	0.900
54.9 (12.7)	1.547	62.1 (16.7)	1.337	69.3 (20.7)	1.160	76.5 (24.7)	1.010	83.7 (28.7)	0.897
55.0 (12.8)	1.541	62.2 (16.8)	1.332	69.4 (20.8)	1.156	76.6 (24.8)	1.007	83.8 (28.8)	0.894
55.2 (12.9)	1.536	62.4 (16.9)	1.327	69.6 (20.9)	1.152	76.8 (24.9)	1.003	84.0 (28.9)	0.892
55.4 (13.0)	1.530	62.6 (17.0)	1.323	69.8 (21.0)	1.148	77.0 (25.0)	1.000	84.2 (29.0)	0.889
55.6 (13.1)	1.524	62.8 (17.1)	1.318	70.0 (21.1)	1.144	77.2 (25.1)	0.997	84.4 (29.1)	0.887
55.8 (13.2)	1.519	63.0 (17.2)	1.313	70.2 (21.2)	1.140	77.4 (25.2)	0.994	84.6 (29.2)	0.884
55.9 (13.3)	1.513	63.1 (17.3)	1.308	70.3 (21.3)	1.136	77.5 (25.3)	0.991	84.7 (29.3)	0.882
56.1 (13.4)	1.508	63.3 (17.4)	1.304	70.5 (21.4)	1.132	77.7 (25.4)	0.988	84.9 (29.4)	0.879
56.3 (13.5)	1.502	63.5 (17.5)	1.299	70.7 (21.5)	1.128	77.9 (25.5)	0.985	85.1 (29.5)	0.877
56.5 (13.6)	1.496	63.7 (17.6)	1.294	70.9 (21.6)	1.124	78.1 (25.6)	0.982	85.3 (29.6)	0.874
56.7 (13.7)	1.491	63.9 (17.7)	1.290	71.1 (21.7)	1.120	78.3 (25.7)	0.979	85.5 (29.7)	0.871
56.8 (13.8)	1.486	64.0 (17.8)	1.285	71.2 (21.8)	1.116	78.4 (25.8)	0.977	85.6 (29.8)	0.869
57.0 (13.9)	1.480	64.2 (17.9)	1.281	71.4 (21.9)	1.112	78.6 (25.9)	0.974	85.8 (29.9)	0.866

OPERATING LOG

- Company Name _____

- Day of Start Up _____

- Location _____

- Date of Last Cleaning _____

- Week Of _____

- System Serial No. _____

Date				
Time				
Hour of Operation				
Filter Inlet Pressure (PSI)				
Filter Outlet Pressure (PSI)				
Concentrate Pressure (PSI)				
Pump Discharge Pressure (PSI)				
Feed Flow (GPM)				
Permeate Flow (GPM)				
Concentrate Flow (GPM)				
Recycle Flow (GPM)				
Recovery %				
Feed Temperature				
Feed TDS (PPM)				
Permeate TDS (PPM)				
Rejection %				
Feed pH				
Permeate pH				
Scale Inhibitor Feed (PPM)				
Iron (mg/L)				
Free Chlorine (mg/L)				
Hardness (GPG CaCO ₃)				

PREPARING UNIT FOR STORAGE OR SHIPMENT



ALL PRESSURE GAUGES MUST READ ZERO BEFORE BEGINNING THESE PROCEDURES. TURN THE SYSTEM OFF, DISCONNECT THE POWER, AND BLEED ALL WATER PRESSURE FROM THE SYSTEM.



PRIOR TO STORING YOUR SYSTEM, THE SYSTEM SHOULD BE CLEANED WITH C – 10 AND C – 20 CLEANERS, FLUSHED WITH PERMEATE WATER AND M – 100 SOLUTION FOR MEMBRANES TO PROTECT IT FROM BIOLOGICAL ATTACK.

PREPARING THE SYSTEM FOR STORAGE

1. We recommend NOT leaving the system idle for more than one week.
2. If the period of non-operation is more than one week, we recommend removing the Membranes, sealing them in a plastic bag, and storing in a refrigerator.
3. If storing Membranes, performance cannot be guaranteed.

During the shut-down period, the area must be kept frost-free, or the ambient temperature must not exceed 120°F (48.8°C) ambient.

PREPARING THE UNIT FOR SHIPMENT

1. Turn the system off and disconnect it from the electrical power supply.
2. Make sure all pressure gauges on the front panel read 0 PSI before continuing.
3. Disconnect the inlet, CONCENTRATE (drain), and PRODUCT (purified water) tubing.
4. Disconnect the feed, PRODUCT (purified water), and CONCENTRATE (drain) tubing from the connectors on the pressure vessels.
5. If there is still water in the flow meters disconnect the tubing on the flow meter inlet.
6. Allow the system to drain for a minimum of eight hours or until the opened ports quit dripping. After draining is complete, reconnect all the plumbing.
7. Prepare the system for storage by following all the above instructions.

TROUBLESHOOTING

SYMPTOMS	POSSIBLE CAUSES	CORRECTIVE ACTION
Low Inlet Pressure	Low supply pressure	Increase inlet pressure
	Pre-filter is plugged	Change pre-filter
	Solenoid valve malfunction	Inspect / replace solenoid valve and/or coil
	Leaks	Fix any visible leaks
Low PRODUCT (purified water) Flow	Cold feedwater	See temperature correction sheet
	Low operating pressure	See low inlet pressure
	Fouled or scaled membrane	Replace membranes
	Pre-filter is plugged	Change pre-filter
High PRODUCT (purified water) Flow	Damaged or oxidized membrane	Replace membranes Close blend valve
	Exceeding maximum feedwater temperature	See temperature correction sheet
	Low operating pressure	See low inlet pressure
Poor PRODUCT (purified water) Quality	Damaged or oxidized membrane	Replace membranes Close blend valve
	Metal oxide fouling	Improve pretreatment to remove metals. Clean with acid cleaners
	Colloidal fouling	Optimize pretreatment for colloid removal. Clean with high pH anionic cleaners
Membrane Fouling	Scaling (CaSO ₄ , CaSO ₃ , BaSO ₄ , SiO ₂)	Increase acid addition and anti-scalant dosage for CaCO ₃ and CaCO ₄ . Reduce recovery. Clean with acid cleaners
	Biological fouling	Shock dosage of sodium bisulfate. Continuous feed of sodium bisulfate at reduced pH. Chlorination and de-chlorination. Replace cartridge filters
	Organic fouling	Activated carbon or another pretreatment. Clean with high pH cleaner
	Abrasion of membrane by crystalline material	Improve pre-treatment. Check all filters for media leakage

TECHNICAL ASSISTANCE

If technical assistance is required:

- Contact HydroLogic directly, toll-free 888-426-5644
- Prior to making the call, have the following information available:
 - System installation date
 - Serial number
 - Daily log sheets
 - Current operating parameters (e.g., flow, operating pressures, pH, etc.)
 - Detailed description of the problem

S-100 CONTROLLER SPECIFICATIONS AND INSTRUCTIONS

INTRODUCTION

The S-100 controller is a state-of-the-art control system for commercial and industrial reverse osmosis systems. The S-100 combines features that have not previously been available in one compact unit.

The S-100 is a microprocessor-controlled system that can monitor pressure and level switches. A TDS monitor/controller with adjustable limit is an integral part of the S-100. The S-100 displays system status and sensor and switch input status using a status LED and a 3-digit LED display.

SPECIFICATIONS

Power: 120/240 VAC -15+10%, 50/60Hz, 6Watts

Environment: -22°F to 140°F, 0-95% RH, noncondensing

Enclosure: 7.6" X 4.6" X 2.4" (193mm X 117mm X 61mm)

Display: 3-digit red LED

Front Panel: Overlay with LED window, status LED, water quality LED, power and setpoint switches

Switch Inputs, Dry Contact:

Pressure fault

Pretreat lockout

Tank full

Relay Outputs:

RO pump relay 120/240VAC, 1HP

Inlet valve relay 120/240VAC, 5A

Flush valve relay 120/240VAC, 5A

Relays supply same output voltage as board power (120 or 240 VAC)

20A maximum total load for all outputs.

* Based on a service factor of 1.0

Cell:

TDS cell with 3-digit display, range: 0-1000PPM. Wetted parts ABS and 316SS, 3/4" NPT, 300 PSI max.

FRONT PANEL CONTROLS AND INDICATORS



LED DISPLAY - Shows status of system and water quality.

STATUS LED - Shows operating status of unit.

WATER QUALITY LED - Green if OK, Red if above limit.

POWER KEY - Places controller in operating or standby mode.

SETPOINT KEY - Places display in mode to display current setpoint.

SYSTEM OPERATION

General Operation

The unit has 2 modes of operation, a standby mode. In the standby mode, the unit is effectively off. All outputs are turned off and the display shows OFF. In the operating mode, the unit operates automatically. All inputs are monitored, and the outputs are controlled accordingly. Pressing the power key will toggle the unit from standby to operate or from operate to standby. If power is removed from the unit, when power is reapplied, the unit will restart in the mode it was in when power was removed.

Display and Status Indicators

The display is a 3-digit display. System operating status, the TDS reading and the TDS setpoint are shown on this display. A red/green LED indicates the system status in conjunction with the display. Refer to Table 1 for the description of the operation of the display and LED.

CONDITION	DISPLAY	STATUS LED
RO OFF	OFF	
RO START DELAY	- - -	
RO OPERATING		STEADY GREEN
TANK FULL	FUL	
TANK FULL RESTART	FUL	SLOW FLASH GREEN
PRETREAT LOCKOUT	PL	
FLUSH	FLS	
PRESSURE FAULT	PF	FLASHING RED
PF AUTO RESET	PF	
PF AUTO RETRY	PF	STEADY RED

Table 1

RO Start Delay

When the controller is placed in the operating mode or restarts from a shutdown condition, the inlet valve will open, and a 30 second time delay will start. During the delay, - - - will show on the water quality display. After this delay, the RO pump will start. The water quality display will now show the current water quality. The status lamp will show steady green.

Pressure Fault

If the pressure fault input is active for 8 seconds, a pressure fault condition will occur. This will cause the controller to shut down. PF will show on the water quality display and the status lamp will flash red. To clear the pressure fault, press the power key twice.

PF Auto Reset/PF Retry

When a pressure fault occurs with the PF auto reset enabled, the controller will automatically reset after a 60-minute delay and the controller will start. If the pressure fault has cleared, the controller will continue to run. If the pressure fault condition is still active, the controller will again shut down for the pressure fault condition and the auto reset cycle will repeat. During the auto reset delay, the water quality display will show PF and the status lamp will be off.

When a pressure fault occurs with the PF retry enabled, the controller will shut down for 30 seconds and then attempt to restart. If the pressure fault is still active, the controller will shut down for 5 minutes and then attempt to restart. If the pressure fault is still active, the controller

will shut down for 30 minutes and attempt to restart. If the pressure fault is still active, the controller will lockout for the pressure fault. During the retry delays, the water quality display will show PF and the status lamp will be a steady red. If during one of the retries, the controller can start and run continuously for 10 seconds, the retry function is reset. If a pressure fault occurs, the PF retry cycle will repeat from the beginning.

If a pressure fault condition occurs, the PF retry function will operate as described above. If the retry function locks out, the PF auto reset function will operate as described above. The PF retry and PF auto reset functions will continue in a 30 second, 5-minute, 30 minute and 60-minute cycle until the pressure fault condition clears.

Tank Full

If the tank full input is active for 5 seconds, the controller will shut down for a tank full condition. The water quality display will show FUL. When the tank full condition clears, the unit will restart after the selected restart delay. During the restart time, the status lamp will flash green.

Pre-treat Lockout

If the pre-treat lockout input is active for 2 seconds, the controller will shut down for a pre-treat lockout condition. The water quality display will show PL. When the pre-treat lockout condition clears, the unit will restart.

Water Quality Display

The water quality display shows the current water quality when the controller is operating normally and status messages when the controller is shut down. The water quality display is 0 - 999PPM. If the water quality is above 999, the display will show ^ ^ ^. If the water quality is below the setpoint, the water quality lamp will be green. If the water quality is above the setpoint, the water quality lamp will be red.

Membrane Flush

When a flush is initiated, the flush valve will operate, and the flush will last 2 minutes. The flush can occur when a tank full condition occurs or every 24 hours, depending on the jumper settings. The inlet valve can be open or closed and the RO pump can be on or off, depending on the jumper settings.

Water Quality Setpoint

The water quality setpoint can be adjusted from 0-999. If set to 999, the water quality lamp will always remain green. To set the water quality setpoint, press the Setpoint key. The display will alternate between the setpoint and SP. Use a small screwdriver to adjust the SP adjustment to the desired setpoint value. Press the Setpoint key to return the display to the water quality display.

Calibration

To adjust the calibration of the water quality, measure the water with a meter calibrated to a known standard. Using a small screwdriver, adjust the CAL adjustment to get the correct reading on the display. Press and hold Setpoint for 30 seconds to go to the calibration mode. You must remove the back of the controller to access the calibration dials. See the electrical wiring diagram on page 34 for location.

TROUBLESHOOTING



HAZARDOUS VOLTAGES ARE PRESENT WHEN POWER IS APPLIED TO THE CONTROLLER. PRESSING THE POWER KEY DOES NOT REMOVE THESE VOLTAGES. THE POWER MUST BE DISCONNECTED FROM THE POWER SOURCE. WHEN CONNECTING OR DISCONNECTING ANY WIRING TO THE UNIT, BE SURE THE POWER IS TURNED OFF AT THE DISCONNECT OR BREAKER. NOTE: IF CONTROLLER FUSE F1 IS BLOWN, THE CONTROLLER WILL BE INOPERATIVE. CONTACT HYDROLOGIC FOR FURTHER INSTRUCTIONS 888-426-5644.

System Inoperative

Is the water quality display lit? If no, check fuse F1 located below the transformer. If the fuse is OK, use a voltmeter to verify that power is applied to power terminals L1 and L2. If power is applied to the power terminals and the above checks are OK, the board may be defective and should be replaced. If no power is applied to the board, check the power wiring to the controller.

Inlet valve will not operate

Is the controller off? If no, are any shut down conditions active? If no, is the inlet LED, I2 lit? If no, replace the board. If yes, check fuse F1. If bad, replace the fuse. If it is OK, check the inlet terminals for power. Is there power? If no, replace the board. If yes, check the valve and valve wiring.

RO Pump Will Not Operate

Is the controller off? If no, are any shut down conditions active? If no, is the RO LED, I1 lit? If no, replace the board. If yes, check fuse F1. If bad, replace the fuse. If it is OK, check the RO pump terminals for power. Is there power? If no, replace the board. If yes, check the pump motor and motor wiring.

HYDROID FLOW DIAGRAM

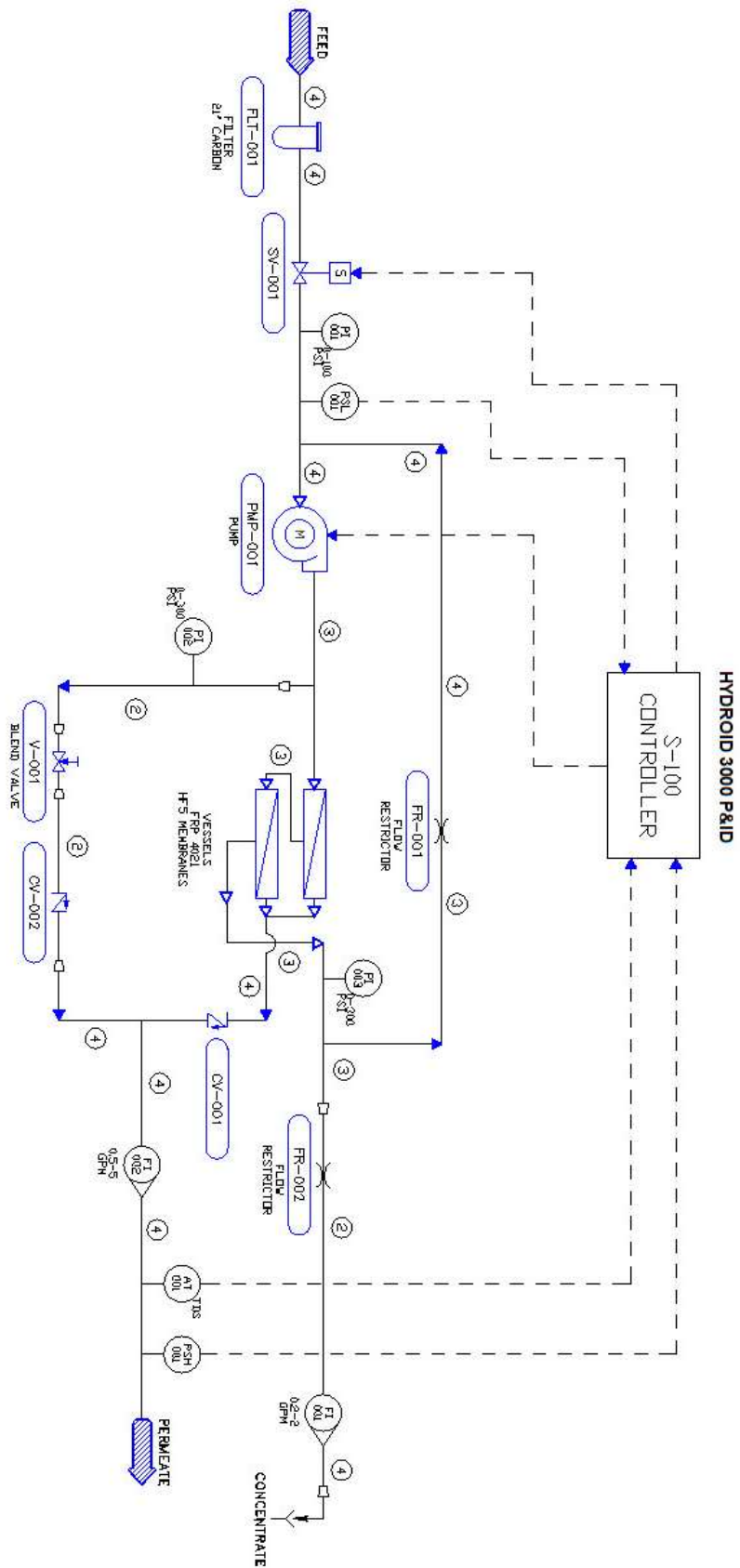

VALVE SYMBOLS		MISCELLANEOUS SYMBOLS	
	BALL VALVE		PUMP
	SOLENOID VALVE		FILTER
	AUTO FLUSH VALVE		FLOW RESTRICTION
	GLOBE VALVE		DIAPHRAGM
	CHECK VALVE		PRESSURE INDICATOR
	REDUCER		PRESSURE SWITCH LOW
	NEEDLE VALVE		TDS INDICATOR
			FLOW MONITOR (WITH MEMBRANE)
			FLOW MONITOR (WITH NEEDLE VALVE)

PIPING SIZE		
STREAM	SIZE	MATERIAL
1	1"	HP POLY TUBE
2	3/4"	LP POLY TUBE
3	1/2"	HP POLY TUBE
4	3/8"	LP POLY TUBE

ELECTRICAL WIRING DIAGRAM

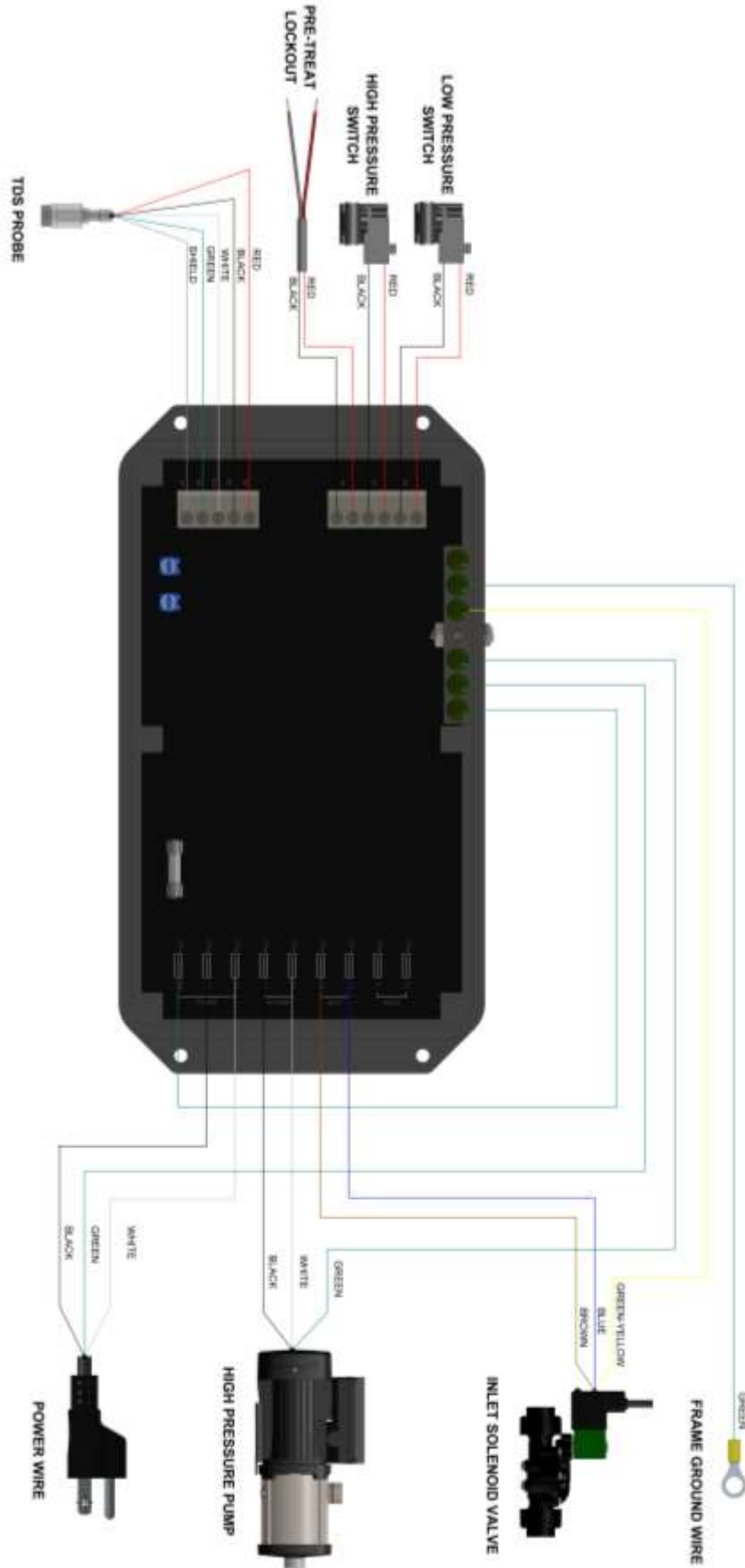

SYSTEM WARRANTY

One-Year Limited Warranty

Warranty Terms

Subject to the terms and conditions set forth hereinafter, manufacturer (hereafter "Manufacturer") warrants to the original purchaser (hereafter the "Customer") that the systems and products manufactured by the Manufacturer are free from defects in material and in workmanship for twelve (12) months from the Warranty Commencement Date (as defined below) only when used strictly in accordance with the applicable operating instructions and within the range of the operating conditions specified by the Manufacturer for each such product.

In order to maintain the Manufacturer's Warranty, an operating log must be maintained, and copies will need to be sent to your local dealer or distributor for review. This Warranty does not extend to systems, equipment, or components manufactured by others, nor to systems, equipment, or components manufactured by others and distributed by the Manufacturer. This Warranty does not extend to equipment or components manufactured by others which have been incorporated into a product by the Manufacturer but, if allowable, the Manufacturer hereby assigns, without Warranty, to the Customer its interest, if any, under any Warranty made by the Manufacturer of such equipment or component. This Warranty does not cover disposable items such as fuses, o-rings, regeneration materials/chemicals, or other such disposable items, which must be replaced periodically under the normal and foreseeable operating conditions of the goods warranted hereby.

Warranty Commencement Date

The Warranty Commencement Date for each product by the Manufacturer shall be the later of the date of: (1) receipt by the Customer, or (2) the date of installation at the Customer's premises provided that such installation must occur within three (3) months of shipment from the Manufacturer's manufacturing facility. In no event shall the Warranty Commencement Date exceed three (3) months from the shipment from Manufacturer's facility. The Customer shall provide proof of purchase in order to exercise rights granted under this Warranty. If requested by the Manufacturer, the Customer must also provide proof of the installation date. Proof of installation shall be returned by Customer to the Manufacturer within thirty (30) days after installation by virtue of supplying a Warranty Validation Card supplied with each Manufacturer product fully completed and signed in ink by the Customer and the authorized installer of the product.

Warranty Service

MANUFACTURER'S OBLIGATION UNDER THIS WARRANTY IS LIMITED TO THE REPAIR OR REPLACEMENT (AT MANUFACTURER'S SOLE DISCRETION) OF ANY PRODUCT, OR COMPONENT THEREOF, PROVED TO BE DEFECTIVE IN MATERIAL OR WORKMANSHIP WITHIN THE COVERED WARRANTY PERIOD.

The Customer, at the Customer's risk and expense, shall be responsible for returning such product or component, only after obtaining a Return Goods Authorization (RGA) number from the Manufacturer, arranging for freight prepaid, and in conformance with any special packaging and shipping instructions set forth on the operation documentation or RGA instructions, or as otherwise reasonably required, to Manufacturer's address, together with (1) RGA number issued by the Manufacturer at Customer's request; (2) proof of purchase and, if necessary, proof of installation date; (3) a Return Goods Authorization Form; (4) a description of the suspected defects; (5) the serial number of the Manufacturer product alleged to be defective; and (6) a description of the type of water and pretreatment equipment which has been utilized in connection with the product, if any; (7) an operating log, which can be found in the product manual. Manufacturer shall, in Manufacturer's reasonable discretion, be the sole judge of whether a returned product or component is defective in material or workmanship.

Required or replaced products or components shall be returned surface freight. In genuine emergency situations, Manufacturer will at Manufacturer's sole discretion) forward replacement parts to Customer without waiting for authorized return of the questionable part(s). In such cases, Customer will issue a purchase order or other payment guarantee prior to shipment. If the returned part is found to have been misused or abused, or the defective part is not received by Manufacturer within thirty (30) days; the Customer will be invoiced for the replacement part(s) provided. This Warranty does not cover or include labor and/or travel to the Customer's

premise or location or any other location. Charges of \$1000 per day plus associated travel expenses will be incurred by the Customer in providing the Warranty Service at any location other than Manufacturer's main headquarters; that is if the Manufacturer deems that the product is not covered by said Warranty. The Manufacturer reserves the right to precondition such travel to Customer's premises upon prepayment of Manufacturer's anticipated costs of attending such premises.

Voidability of Warranty

This Warranty shall be void and unenforceable as to any Manufacturer product which has been damaged by accident, mishandling, abuse or has been repaired, modified, altered, disassembled or otherwise tampered with by anyone other than Manufacturer or an authorized Manufacturer service representative; or, if any replacement parts are not authorized by Manufacturer have been used, or, the product has not been installed, operated and maintained in strict accordance and adherence with the operating documentation and manuals for such product. Any expressed Warranty, or similar representation of performance set forth in the operation documentation for media or resin incorporated into a product by the Manufacturer shall be void and unenforceable unless the feed water requirements set forth in the operating documentation for such product are unequivocally and strictly adhered to.

Limitations and Exclusions

THIS WARRANTY AND REMEDIES DESCRIBED HEREIN AND HEREINABOVE ARE EXCLUSIVE AND IN LIEU OF ANY AND ALL OTHER WARRANTY OR REMEDIES, EXPRESSED OR IMPLIED, INCLUDING WITHOUT LIMITATION, ANY IMPLIED WARRANTY OF MERCHANTABILITY OR FITNESS FOR A PARTICULAR PURPOSE. IN NO EVENT SHALL THE MANUFACTURER BE LIABLE FOR ANY CONSEQUENTIAL, INCIDENTAL OR OTHER SIMILAR TYPES OF DAMAGES, FOR DAMAGES FOR THE LOSS OF PRODUCTION OR PROFITS, OR INJURY TO PERSON OR PROPERTY. NO PERSON HAS ANY AUTHORITY TO BIND THE MANUFACTURER TO OTHER THAN WHAT IS SET FORTH ABOVE.

THIS WARRANTY GIVES THE CUSTOMER SPECIFIC LEGAL RIGHTS AND THE CUSTOMER MAY ALSO HAVE OTHER RIGHTS WHICH VARY FROM JURISDICTION TO JURISDICTION. THE PARTIES RECOGNIZE AND AGREE, THAT IN ALL RESPECTS THE LAWS OF THE STATE OF CALIFORNIA SHALL APPLY TO AND SHALL GOVERN ANY INTERPRETATION OR LEGAL SIGNIFICANCE OF THIS DOCUMENT.

NO WARRANTY OR OTHER LIABILITY OF THE MANUFACTURER TO CUSTOMER UNDER THIS AGREEMENT OR OTHERWISE WILL IN ANY EVENT EXCEED THE COST OF REPLACEMENT OF THE APPLICABLE MANUFACTURER PRODUCT, PART, OR ACCESSORY THAT IS SUBJECT TO ANY BREACH OF MANUFACTURER'S WARRANTY. MANUFACTURER WILL NOT BE LIABLE FOR ANY DAMAGE TO ANY PROPERTY OF CUSTOMER OR TO CUSTOMER'S CUSTOMERS FOR ANY CONSEQUENTIAL, INCIDENTAL, OR ECONOMIC LOSS OR COMMERCIAL DAMAGE WHATSOEVER. REMEDIES HEREIN PROVIDED ARE EXPRESSLY MADE THE SOLE AND EXCLUSIVE REMEDIES FOR BREACH OF ANY WARRANTY OR OTHER OBLIGATION HEREUNDER EXPRESS OR IMPLIED OR FROM THE OPERATION OF LAW.

HYDROID

BY

HydroLogic[®]
PURIFICATION SYSTEMS

370 Encinal Street
Suite 150
Santa Cruz, CA
95060

ph: 888.426.5644
fax: 831.336.9840

info@hydrologicsystems.com
hydrologicsystems.com

MEMBER



ACCREDITED
BUSINESS

