



**Hewlett Packard
Enterprise**

HPE Apollo 4510 Gen9 Chassis Setup and Installation Guide

Abstract

This document contains setup, installation, and configuration information for the HPE Apollo 4510 Gen9 Chassis. This document is for the person who installs, administers, and troubleshoots servers and storage systems. Hewlett Packard Enterprise assumes you are qualified in the servicing of computer equipment and trained in recognizing hazards in products with hazardous energy levels.

Part Number: 819250-005
Published: September 2018
Edition: 5

Notices

The information contained herein is subject to change without notice. The only warranties for Hewlett Packard Enterprise products and services are set forth in the express warranty statements accompanying such products and services. Nothing herein should be construed as constituting an additional warranty. Hewlett Packard Enterprise shall not be liable for technical or editorial errors or omissions contained herein.

Confidential computer software. Valid license from Hewlett Packard Enterprise required for possession, use, or copying. Consistent with FAR 12.211 and 12.212, Commercial Computer Software, Computer Software Documentation, and Technical Data for Commercial Items are licensed to the U.S. Government under vendor's standard commercial license.

Links to third-party websites take you outside the Hewlett Packard Enterprise website. Hewlett Packard Enterprise has no control over and is not responsible for information outside the Hewlett Packard Enterprise website.

Contents

- Planning the installation.....5**
 - Verifying the pallet contents..... 5
 - Warnings and cautions.....6
 - Space and airflow requirements..... 7
 - Temperature requirements.....7
 - Power requirements.....8
 - Grounding requirements..... 8

- Identifying components and LEDs..... 9**
 - Front panel components..... 9
 - Storage display LEDs.....9
 - Server front panel components..... 10
 - Server front panel LEDs and buttons..... 11
 - Rear panel components.....12
 - Power supply LEDs12
 - Management module components.....13
 - Management module LEDs.....14
 - I/O module components.....14
 - I/O module LEDs.....15
 - PCIe slot definitions (standard I/O module).....15
 - PCIe slot definitions (I/O module with x16 riser option).....16
 - HPE Smart Array P440 Controller port identification.....18
 - HPE Smart Array P840 Controller port identification.....18
 - HPE H240 Smart Host Bus Adapter port identification.....19
 - I/O module power connector identification.....19
 - LFF drive bay numbering.....20
 - LFF drive LED definitions.....20
 - Optional 8LFF drive cage bay numbering.....22

- Installing the chassis.....23**
 - Setting up and installing the chassis.....23
 - Disassembling the chassis.....23
 - Installing the chassis into the rack.....27
 - Installing the system components into the chassis.....30
 - Installing a server.....30
 - Installing a hot-plug drive.....31
 - Installing a flex slot power supply.....32
 - Installing the system fan.....33
 - Installing a management module.....34
 - Installing the expansion board.....34
 - Installing an I/O module.....36
 - Installing the HPE Smart Storage Battery option.....37

- Cabling and powering up the chassis.....39**
 - Cabling the chassis.....39
 - Installing the cable management arm.....39

Converting the cable management arm for opposite side mounting.....	41
I/O module option cabling.....	42
HPE Smart Array P440 Controller cabling.....	42
HPE Smart Array P840 Controller cabling.....	43
HPE H240 Smart Host Bus Adapter cabling.....	44
Powering up the system.....	45
Hot-plug power supply calculations.....	45
Power capping.....	45
Power capping modes.....	45
Configuring a power cap.....	46
Setting the chassis power cap mode with the PPIC utility.....	46
Setting the chassis power cap mode with HPE APM.....	47
Troubleshooting.....	48
Important safety information	48
Symbols on equipment.....	48
Troubleshooting resources.....	49
Specifications.....	50
Environmental specifications	50
Chassis specifications	50
Power supply specifications.....	50
HPE 800W Flex Slot Platinum Hot-plug Low Halogen Power Supply.....	51
HPE 800W Flex Slot -48VDC Hot-plug Low Halogen Power Supply.....	51
HPE 800W Flex Slot Titanium Hot-plug Low Halogen Power Supply.....	53
HPE 800W Flex Slot Universal Hot-plug Low Halogen Power Supply.....	53
HPE 1400W Flex Slot Platinum Plus Hot-plug Power Supply.....	54
Hot-plug power supply calculations.....	55
Environmental considerations.....	56
Communications interference.....	56
Preventing electrostatic discharge.....	56
Grounding methods to prevent electrostatic discharge.....	56
Websites.....	58
Support and other resources.....	59
Accessing Hewlett Packard Enterprise Support.....	59
Accessing updates.....	59
Customer self repair.....	60
Remote support.....	60
Warranty information.....	60
Regulatory information.....	61
Documentation feedback.....	61
Acronyms and abbreviations.....	62

Planning the installation

Verifying the pallet contents

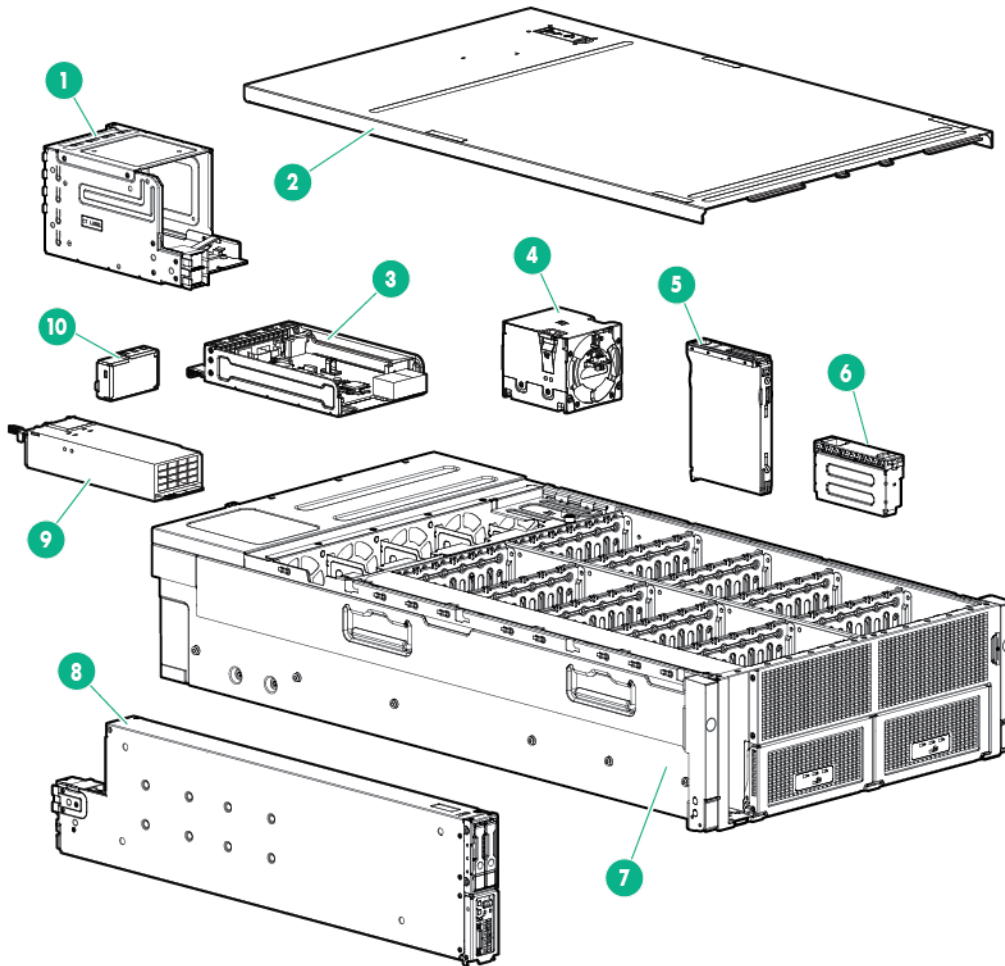

Item	Description
1	I/O module
2	Access panel
3	Management module
4	System fans (5)
5	Drives ¹
6	Drive blank
7	HPE Apollo 4510 Gen9 Chassis
8	Server
9	Power supply ¹

Table Continued

Item	Description
10	Power supply blank
11	Rack rails and cable management arm ²

¹ The quantity depends on the configuration ordered.

² Not shown

Warnings and cautions

 **WARNING:** To reduce the risk of personal injury or damage to equipment, heed all warnings and cautions throughout the installation instructions.

 **WARNING:** To reduce the risk of personal injury or damage to the equipment, be sure that:

- The rack is bolted to the floor using the concrete anchor kit.
 - The leveling feet extend to the floor.
 - The full weight of the rack rests on the leveling feet.
 - The racks are coupled together in multiple rack installations.
 - Only one component is extended at a time. If more than one component is extended, a rack might become unstable.
-

 **WARNING:** The chassis is very heavy. To reduce the risk of personal injury or damage to the equipment:

- Observe local occupational health and safety requirements and guidelines for manual material handling.
 - Remove all installed components from the chassis before installing or moving the chassis.
 - Use caution and get help to lift and stabilize the chassis during installation or removal, especially when the chassis is not fastened to the rack.
-

 **WARNING:** To reduce the risk of personal injury or damage to the equipment, you must adequately support the chassis during installation and removal.

 **WARNING:** Always have at least two people to lift the chassis into the rack. If the chassis is being loaded into the rack above chest level, an additional person must assist with aligning the chassis with the rails while the other people support the weight of the chassis.

 **WARNING:** Be sure to install enclosures starting from the bottom of the rack and work your way up the rack.

 **WARNING:** To reduce the risk of personal injury from hot surfaces, allow the drives and the internal system components to cool before touching them.

-
- ⚠ WARNING:** To reduce the risk of electric shock or damage to the equipment:
- Never reach inside the chassis while the system is powered up.
 - Perform service on system components only as instructed in the user documentation.
-

⚠ CAUTION: Always be sure that equipment is properly grounded and that you follow proper grounding procedures before beginning any installation procedure. Improper grounding can result in ESD damage to electronic components. For more information, see **Preventing electrostatic discharge**.

⚠ CAUTION: When performing non-hot-plug operations, you must power down the chassis and/or the system. However, it may be necessary to leave the chassis powered up when performing other operations, such as hot-plug installations or troubleshooting.

Space and airflow requirements

To enable servicing and ensure adequate airflow, observe the following spatial requirements when deciding where to install a rack:

- Leave a minimum clearance of 121.9 cm (48.0 in) in front of the rack and between rows of racks.
- Leave a minimum clearance of 76.2 cm (30.0 in) in back of the rack for a single row of racks or after the final row of racks.

Hewlett Packard Enterprise Rack products draw cool air in through the front and expel warm air through the rear of the enclosure. Therefore, the front of the rack enclosure must be adequately ventilated to enable ambient room air to enter the enclosure, and the rear of the enclosure must be adequately ventilated to enable the warm air to escape from the enclosure.

ⓘ IMPORTANT: Do not block the ventilation openings.

If the front of the rack is not completely filled with components, the remaining gaps between the components can cause changes in the airflow, which can adversely affect cooling within the rack. Cover these gaps with blanking panels.

⚠ CAUTION: Always use blanking panels to fill empty vertical spaces in the rack. This arrangement ensures proper airflow. Using a rack without blanking panels results in improper cooling that can lead to thermal damage.

Racks provide proper server cooling from flow-through perforations in the front and rear doors that provide a 65% open area for ventilation.

Temperature requirements

To ensure continued safe and reliable equipment operation, install or position the rack in a well-ventilated, climate-controlled environment.

The operating temperature inside the rack is always higher than the room temperature and is dependent on the configuration of equipment in the rack. Check the TMRA for each piece of equipment before installation.

⚠ CAUTION: To reduce the risk of damage to the equipment when installing third-party options:

- Do not permit optional equipment to impede airflow around the chassis or to increase the internal rack temperature beyond the maximum allowable limits.
 - Do not exceed the manufacturer's TMRA.
-

Power requirements

Installation of this equipment must comply with local and regional electrical regulations governing the installation of IT equipment by licensed electricians. This equipment is designed to operate in installations covered by NFPA 70, 1999 Edition (National Electric Code) and NFPA-75, 1992 (code for Protection of Electronic Computer/Data Processing Equipment). For electrical power ratings on options, refer to the product rating label or the user documentation supplied with that option.

⚠ WARNING: To reduce the risk of personal injury, fire, or damage to the equipment, do not overload the AC supply branch circuit that provides power to the rack. Consult the electrical authority having jurisdiction over wiring and installation requirements of your facility.

⚠ CAUTION: Protect the chassis from power fluctuations and temporary interruptions with a regulating UPS. This device protects the hardware from damage caused by power surges and voltage spikes and keeps the chassis in operation during a power failure.

Grounding requirements

This equipment must be grounded properly for proper operation and safety. In the United States, you must install the equipment in accordance with NFPA 70, 1999 Edition (National Electric Code), Article 250, as well as any local and regional building codes.

In Canada, you must install the equipment in accordance with Canadian Standards Association, CSA C22.1, Canadian Electrical Code.

In all other countries, you must install the equipment in accordance with any regional or national electrical wiring codes, such as the International Electrotechnical Commission (IEC) Code 364, parts 1 through 7. Furthermore, you must be sure that all power distribution devices used in the installation, such as branch wiring and receptacles, are listed or certified grounding-type devices.

Because of the high ground-leakage currents associated with this equipment, Hewlett Packard Enterprise recommends the use of a PDU that is either permanently wired to the building's branch circuit or includes a nondetachable cord that is wired to an industrial-style plug. NEMA locking-style plugs or those complying with IEC 60309 are considered suitable for this purpose. Using common power outlet strips to supply power to this equipment is not recommended.

Identifying components and LEDs

Front panel components

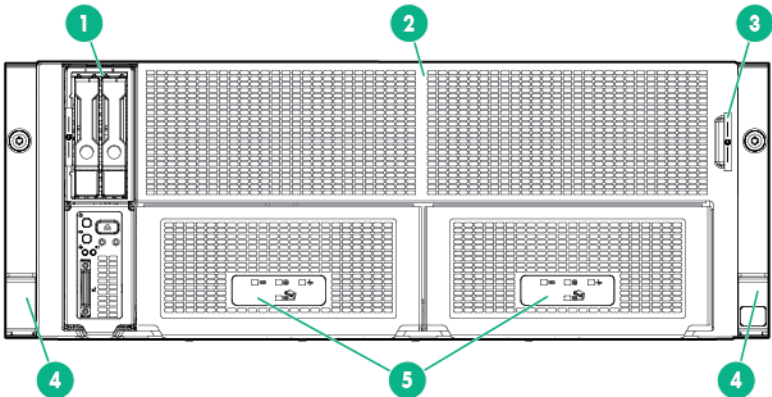

Item	Description
1	Server bay
2	Server bay LFF drives
3	Chassis serial label pull tab
4	Quick-release levers (2)
5	Storage LED display

Storage display LEDs

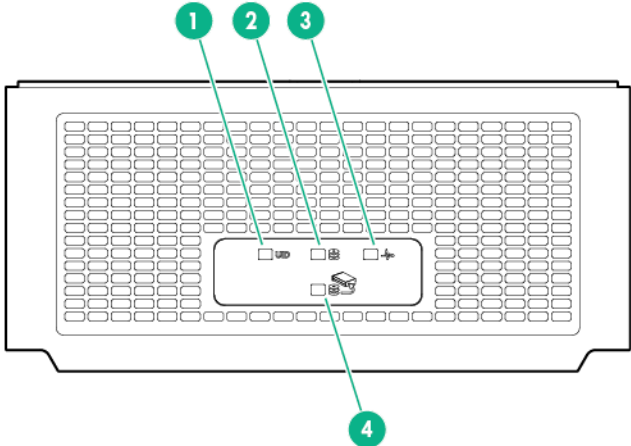

Item	LED description	LED state
1	UID LED	<p>Off = Normal operating mode</p> <p>Solid blue = One or more drives is in locate mode.</p> <p>Flashing blue = Firmware update is in progress.</p>
2	Drive health LED	<p>Off = No drives are configured.</p> <p>Solid green = One or more drives are members of a logical drive.</p> <p>Flashing green = One or more drives are rebuilding or performing a RAID migration, stripe size migration, capacity expansion, logical drive extension, or erasing.</p> <p>Flashing amber = One or more drives are predicted to fail.</p> <p>Solid amber = One or more drives have failed.</p>
3	Backplane health LED	<p>Green = Backplane health is normal.</p> <p>Amber = Backplane error detected</p>
4	Rear drive health LED	<p>Off = No drives are configured.</p> <p>Solid green = One or more drives are members of a logical drive.</p> <p>Flashing green = One or more drives are rebuilding or performing a RAID migration, stripe size migration, capacity expansion, logical drive extension, or erasing.</p> <p>Flashing amber = One or more drives are predicted to fail.</p> <p>Solid amber = One or more drives have failed.</p>

Server front panel components

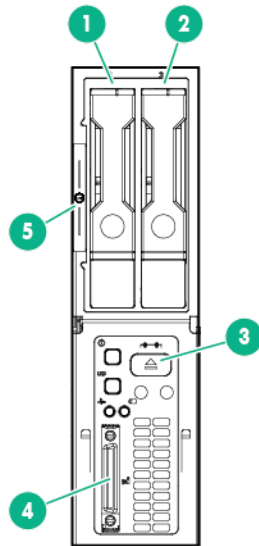

Item	Description
1	Drive bay 1
2	Drive bay 2
3	Server ejector button
4	SUV cable connector
5	Server serial label pull tab

Server front panel LEDs and buttons

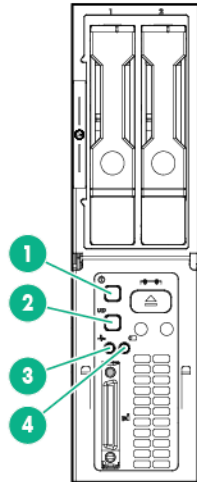

Item	Description	Status
1	Power On/Standby button and system power LED	<p>Solid green = System on</p> <p>Flashing green (1 Hz/cycle per sec) = Performing power on sequence</p> <p>Solid amber = System in standby</p> <p>Off = No power present</p>
2	UID button/LED	<p>Solid blue = Activated</p> <p>Flashing blue:</p> <ul style="list-style-type: none"> • 1 Hz/cycle per sec = Remote management or firmware upgrade in progress • 4 Hz/cycle per sec = iLO manual reboot sequence initiated • 8 Hz/cycle per sec = iLO manual reboot sequence in progress <p>Off = Deactivated</p>

Table Continued

Item	Description	Status
3	Server health LED	Solid green = Normal Flashing green (1 Hz/cycle per sec) = iLO is rebooting Flashing amber = System degraded Flashing red (1 Hz/cycle per sec) = System critical
4	Server backup LED	Off = Normal operations. No backup in progress. Flashing white = Backup in progress. Do not remove drives or associated system components, and do not power down the server.

Rear panel components

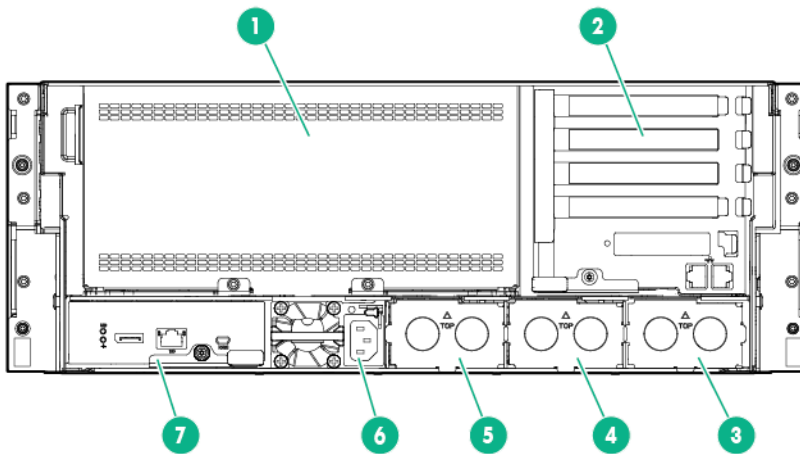

Item	Description
1	Rear LFF drive cage blank
2	I/O module
3	Power supply bay 4
4	Power supply bay 3
5	Power supply bay 2
6	Power supply bay 1
7	Management module

Power supply LEDs

The power supply LED is located on each power supply.

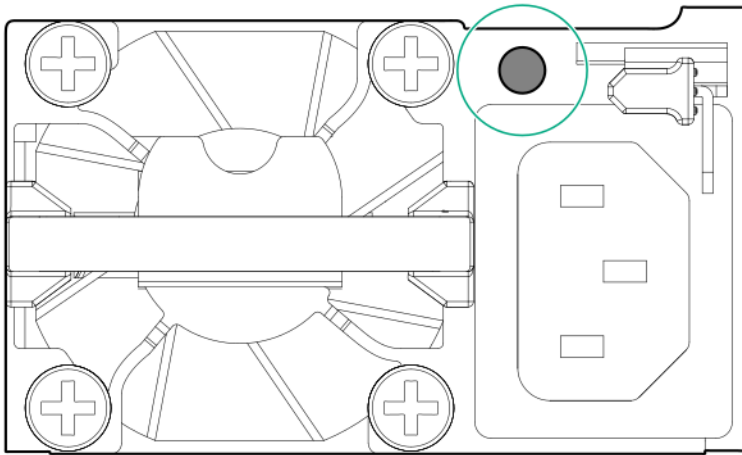

LED Status	Description
Off	System is off or power supply has failed.
Solid Green	Normal

Management module components

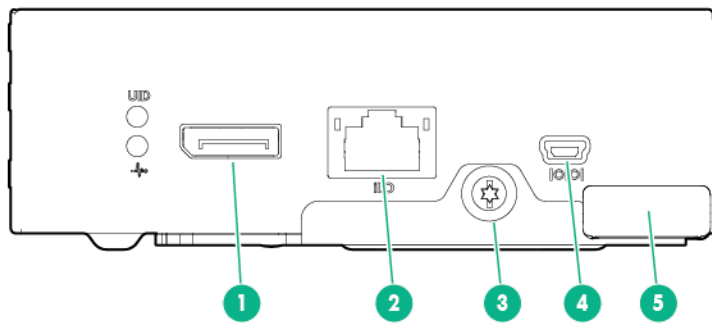

Item	Description
1	HPE APM connector
2	HPE iLO connector
3	Management module thumbscrew
4	Reserved
5	Management module release lever

Management module LEDs

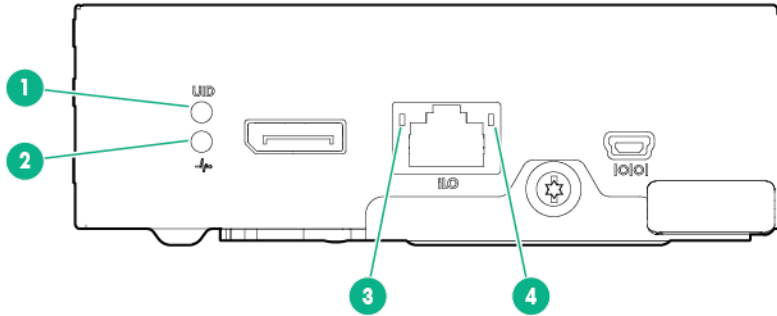

Item	Description
1	Management module UID LED
2	Management module health LED
3	iLO link LED
4	iLO activity LED

I/O module components

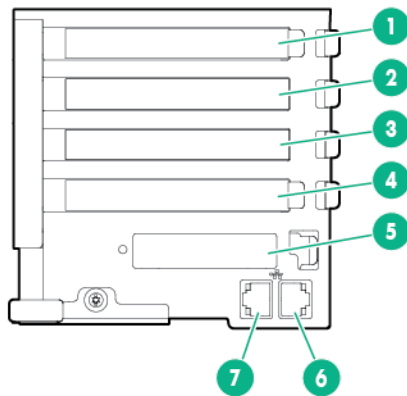

Item	Description
1	PCIe expansion slot 4
2	PCIe expansion slot 3
3	PCIe expansion slot 2
4	PCIe expansion slot 1

Table Continued

Item	Description
5	FlexibleLOM slot
6	NIC 2
7	NIC 1

The FlexibleLOM slot is not available on the I/O module with the x16 PCIe riser option.

I/O module LEDs

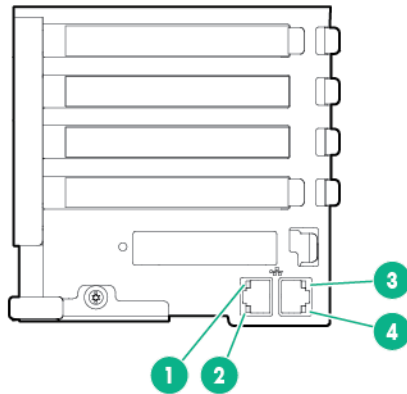

Item	Description
1	NIC 1 activity LED
2	NIC 1 link LED
3	NIC 2 activity LED
4	NIC 2 link LED

PCIe slot definitions (standard I/O module)

The HPE Apollo 4500 system with its centralized HPE Smart Storage Battery supports up to two HPE Smart Array controllers per node.

Processor 2 must be installed to support options installed in PCIe expansion slots 3 and 4.

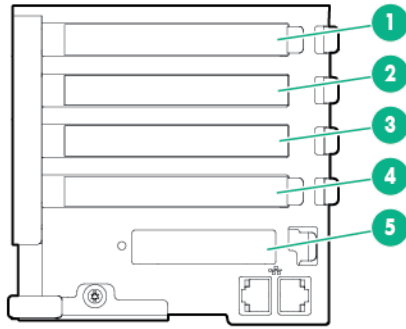

Item	Description
1	PCIe expansion slot 4 — PCIe3 x8 (8, 4, 2, 1)
2	PCIe expansion slot 3 — PCIe3 x8 (8, 4, 2, 1)
3	PCIe expansion slot 2 — PCIe3 x8 (8, 4, 2, 1)
4	PCIe expansion slot 1 — PCIe3 x8 (8, 4, 2, 1)
5	FlexibleLOM slot — PCIe3 x8

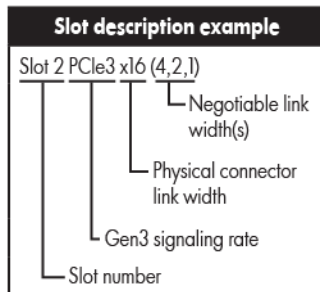

PCIe slot definitions (I/O module with x16 riser option)

The HPE Apollo 4500 system with its centralized HPE Smart Storage Battery supports up to two HPE Smart Array controllers per node.

Processor 2 must be installed to support options installed in PCIe expansion slots 3 and 4. Only slots 3 and 4 support HPE Smart Array Controllers.

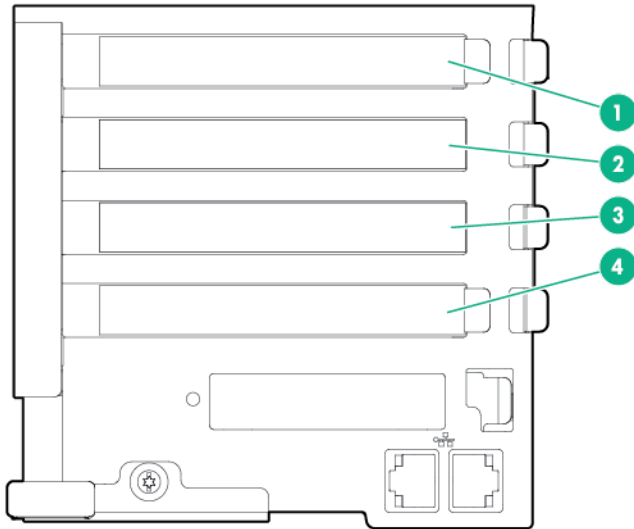

Item	Description
1	PCIe expansion slot 4 — PCIe3 x8 (8, 4, 2, 1)
2	PCIe expansion slot 3 — PCIe3 x8 (8, 4, 2, 1)
3	PCIe expansion slot 2 — PCIe3 x16 (16, 8, 4, 2, 1)
4	PCIe expansion slot 1 — PCIe3 x8 (8, 4, 2, 1)

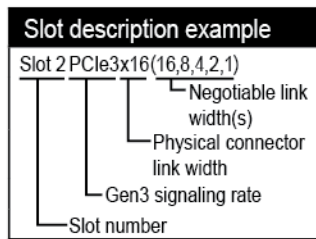

HPE Smart Array P440 Controller port identification

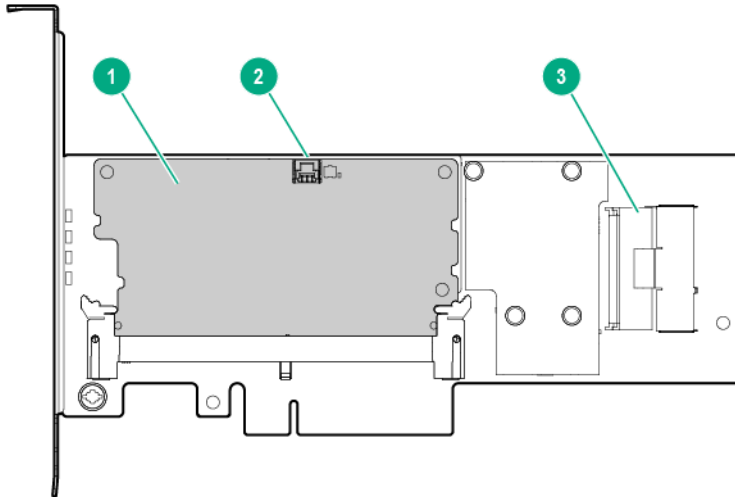

Item	Description
1	Cache module
2	Cache module cable connector
3	Internal SAS port 1i

HPE Smart Array P840 Controller port identification

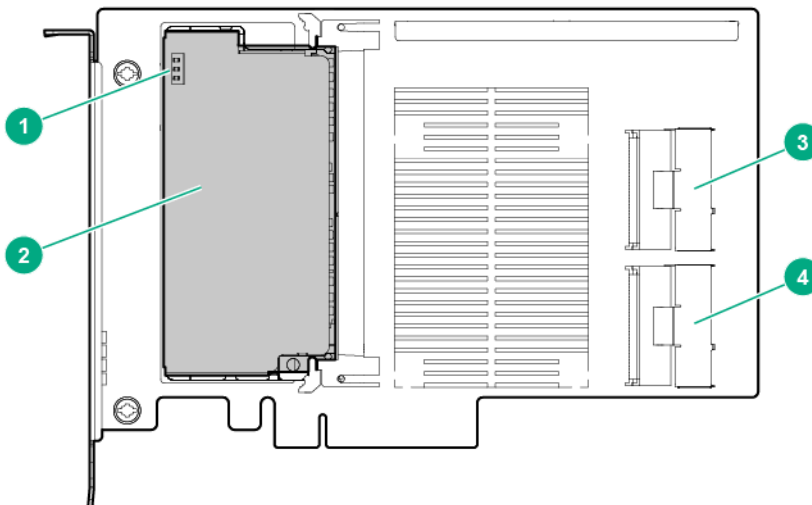

Item	Description
1	Cache module cable connector
2	Cache module
3	Internal SAS port 1i
4	Internal SAS port 2i

HPE H240 Smart Host Bus Adapter port identification

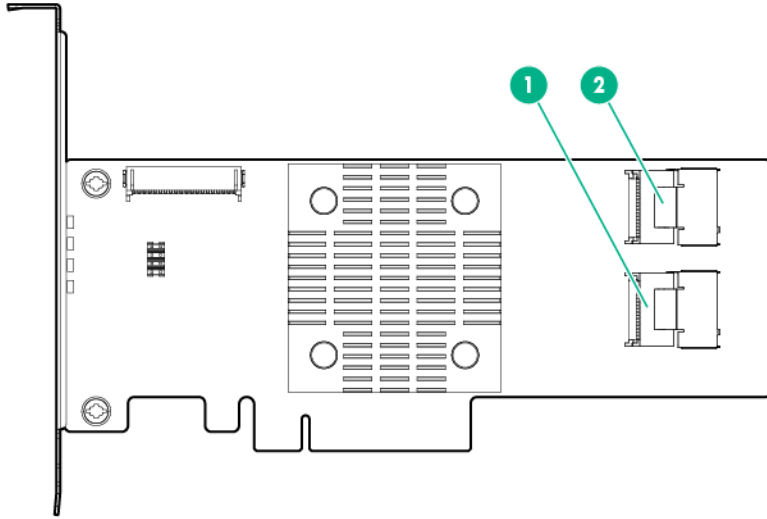

Item	Description
1	Port 2i
2	Port 1i

I/O module power connector identification

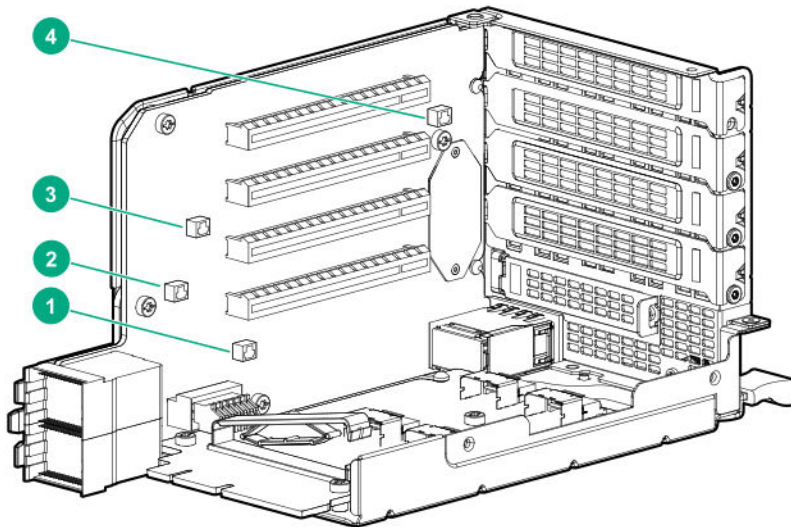

Item	Description
1	PCIe expansion slot 1 power connector
2	PCIe expansion slot 2 power connector
3	PCIe expansion slot 3 power connector
4	PCIe expansion slot 4 power connector

LFF drive bay numbering

The drives are numbered 1-60 for each server installed in the chassis. The first digit in the illustration represents the server associated with the drive and the second set of digits represent the drive bay number.

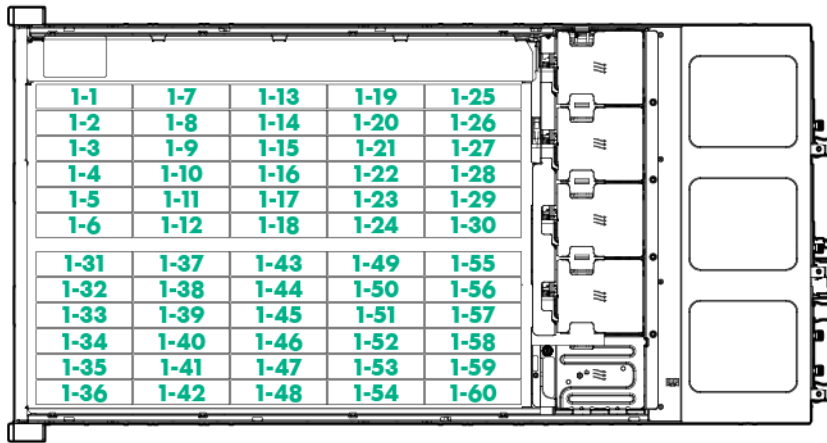

LFF drive LED definitions

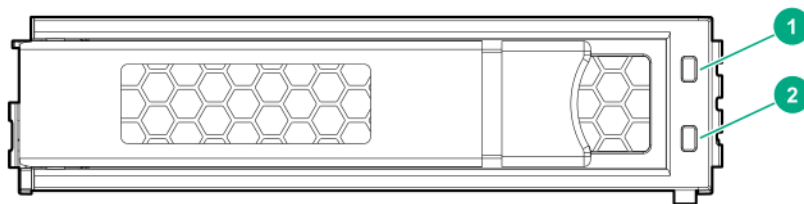

Item	Definition
1	Fault/UID (amber/blue)
2	Online/Activity (green)

Online/Activity LED (green)	Fault/UID LED (amber/blue)	Definition
On, off, or flashing	Alternating amber and blue	One or more of the following conditions exist: <ul style="list-style-type: none"> • The drive has failed. • A predictive failure alert has been received for this drive. • The drive has been selected by a management application.
On, off, or flashing	Solid blue	One or both of the following conditions exist: <ul style="list-style-type: none"> • The drive is operating normally. • The drive has been selected by a management application.
On	Flashing amber	A predictive failure alert has been received for this drive. Replace the drive as soon as possible.
On	Off	The drive is online but is not currently active.
1 flash per second	Flashing amber	Do not remove the drive. Removing the drive might terminate the current operation and cause data loss. The drive is part of an array that is undergoing capacity expansion or stripe migration, but a predictive failure alert has been received for this drive. To minimize the risk of data loss, do not remove the drive until the expansion or migration is complete.
1 flash per second	Off	Do not remove the drive. Removing the drive might terminate the current operation and cause data loss. The drive is rebuilding, erasing, or is part of an array that is undergoing capacity expansion or stripe migration.
4 flashes per second	Flashing amber	The drive is active but a predictive failure alert has been received for this drive. Replace the drive as soon as possible.
4 flashes per second	Off	The drive is active and is operating normally.
Off	Solid amber	A critical fault condition has been identified for this drive and the controller has placed it offline. Replace the drive as soon as possible.
Off	Flashing amber	A predictive failure alert has been received for this drive. Replace the drive as soon as possible.
Off	Off	The drive is offline, a spare, or not configured as part of an array.

Optional 8LFF drive cage bay numbering

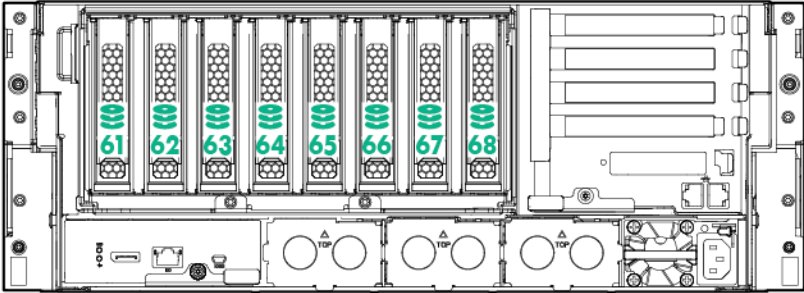

Installing the chassis

Setting up and installing the chassis

Procedure

1. Set up and install the rack. For more information, see the documentation that ships with the rack.
2. **Disassemble the chassis.**
3. **Install the chassis into the rack.**
4. **Install the system components into the chassis.**

Disassembling the chassis

Prerequisites

- Before installing the chassis into the rack, you must remove the pluggable modules and system components from the chassis.
- Because a fully populated chassis can weigh up to 99.79 kg (220.00 lb), remove the components from the chassis to make moving and installing the chassis easier.

Procedure

1. With the chassis still on the pallet, remove all components from the front and rear of the chassis:

- Power supplies

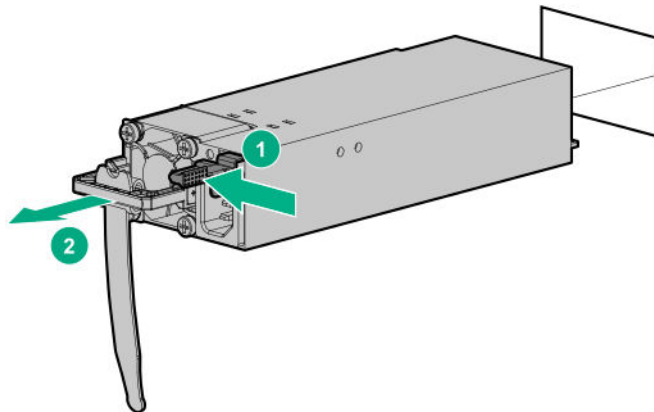

- Management module

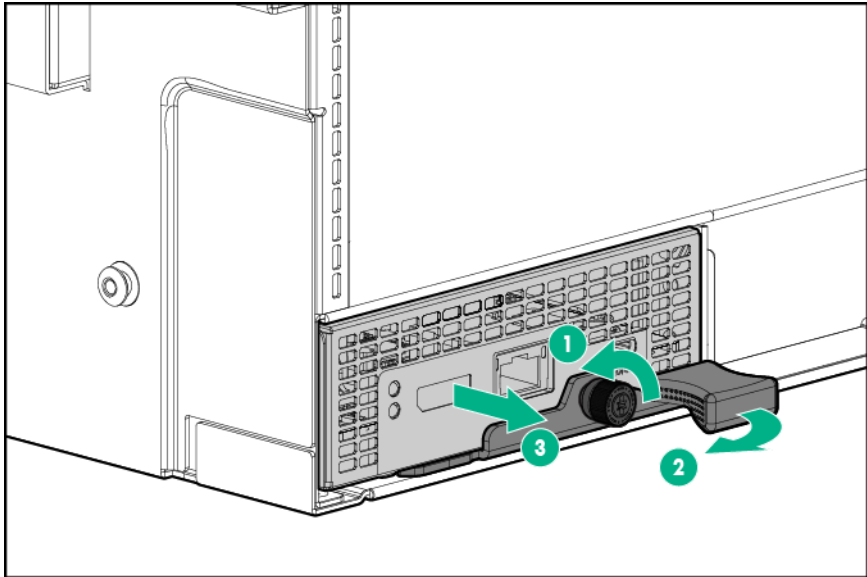

- I/O module

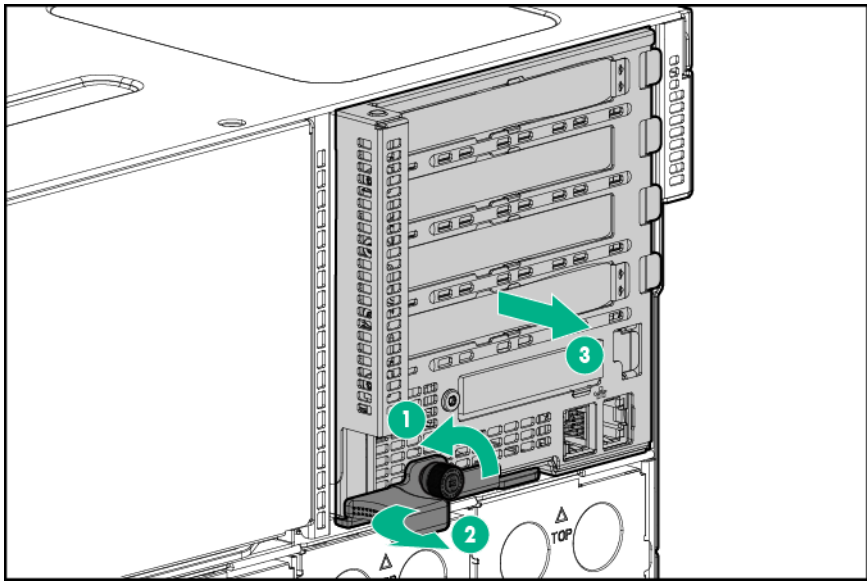

⚠ CAUTION: To avoid damage to the server, always support the bottom of the server when removing it from the chassis.

- Server

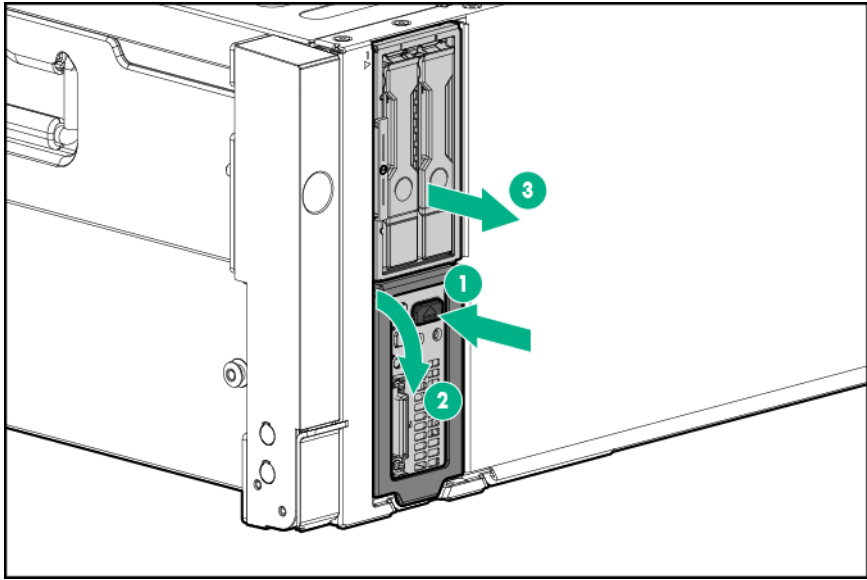

⚠ CAUTION: To avoid damage to the device, do not use the removal handle to carry it.

2. Remove the access panel.

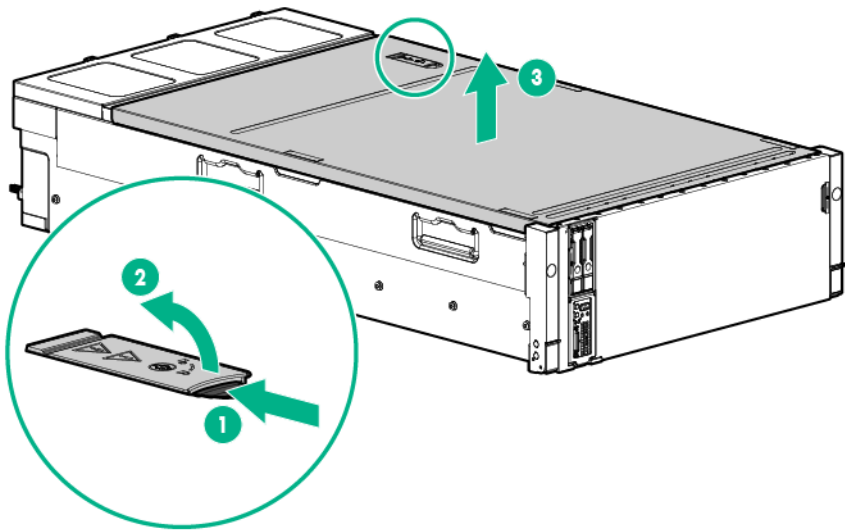

3. Remove all LFF drives.

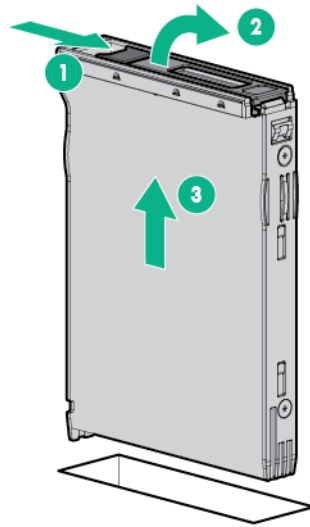

4. System fans (bays 1 through 4):

- a. In bay 5, open the fan bay door.

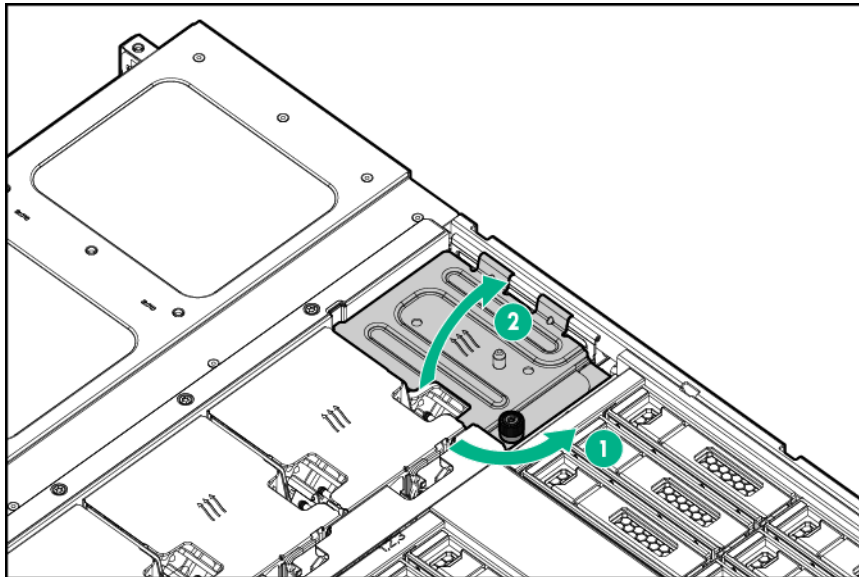

- b. Remove the system fans from all 5 fan bays.

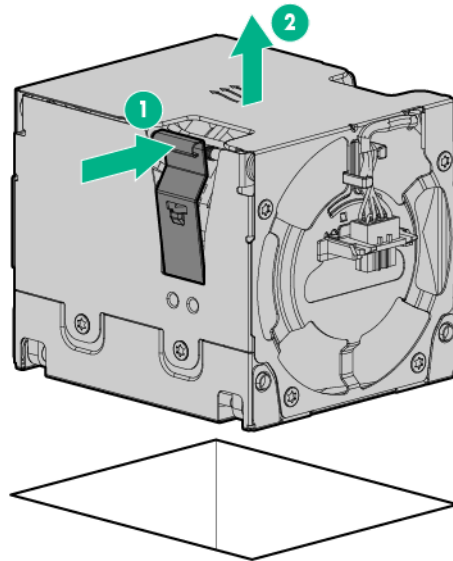

Installing the chassis into the rack

-
- ⚠ WARNING:** Always have at least two people to lift the chassis into the rack. If the chassis is being loaded into the rack above chest level, an additional person must assist with aligning the chassis with the rails while the other people support the weight of the chassis.
-
- ⚠ WARNING:** The chassis is very heavy. To reduce the risk of personal injury or damage to the equipment:
- Observe local occupational health and safety requirements and guidelines for manual material handling.
 - Remove all installed components from the chassis before installing or moving the chassis.
 - Use caution and get help to lift and stabilize the chassis during installation or removal, especially when the chassis is not fastened to the rack.
-
- ⚠ WARNING:** To avoid risk of personal injury or damage to the equipment, do not stack anything on top of rail-mounted equipment or use it as a work surface when extended from the rack.
-
- ⚠ CAUTION:** Always plan the rack installation so that the heaviest item is on the bottom of the rack. Install the heaviest item first, and continue to populate the rack from the bottom to the top.
-
- ⚠ CAUTION:** Hewlett Packard Enterprise has not tested or validated the chassis with any third-party racks. Before installing the chassis in a third-party rack, be sure to properly scope the limitations of the rack. Before proceeding with the installation, consider the following:
- You must fully understand the static and dynamic load carrying capacity of the rack and be sure that it can accommodate the weight of the chassis.
 - Be sure sufficient clearance exists for cabling, installation and removal of the chassis, and actuation of the rack doors.
-

The chassis requires rails for installation in a rack. To install the rack rails, see the Quick Deploy Rail System Installation Instructions that ship with the rack hardware kit.

You can install up to nine chassis in a 36U, 1200mm deep rack. If you are installing more than one chassis, install the first chassis in the bottom of the rack, and then install additional chassis by moving up the rack with each subsequent chassis. Plan the rack installation carefully because it is difficult to change the location of components after they are installed.

⚠ WARNING: To reduce the risk of personal injury or damage to the equipment, be sure that:

- The rack is bolted to the floor using the concrete anchor kit.
- The leveling feet extend to the floor.
- The full weight of the rack rests on the leveling feet.
- The racks are coupled together in multiple rack installations.
- Only one component is extended at a time. If more than one component is extended, a rack might become unstable.

⚠ WARNING: To reduce the risk of personal injury or equipment damage, be sure that the rack is adequately stabilized before installing the chassis.

⚠ WARNING: To reduce the risk of personal injury or damage to the equipment, you must fully extend the rails. To fully extend the rails, press the push tabs and extend the rails until the rails click twice.

Procedure

1. Extend the rails until they stop.

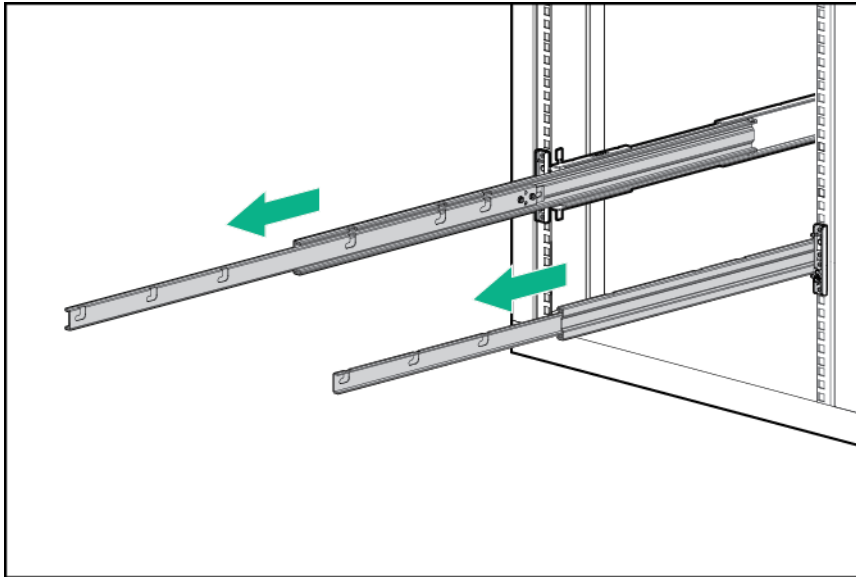

2. Fully extend the rails by pressing the push tabs and extending the rails until the rails click two times.

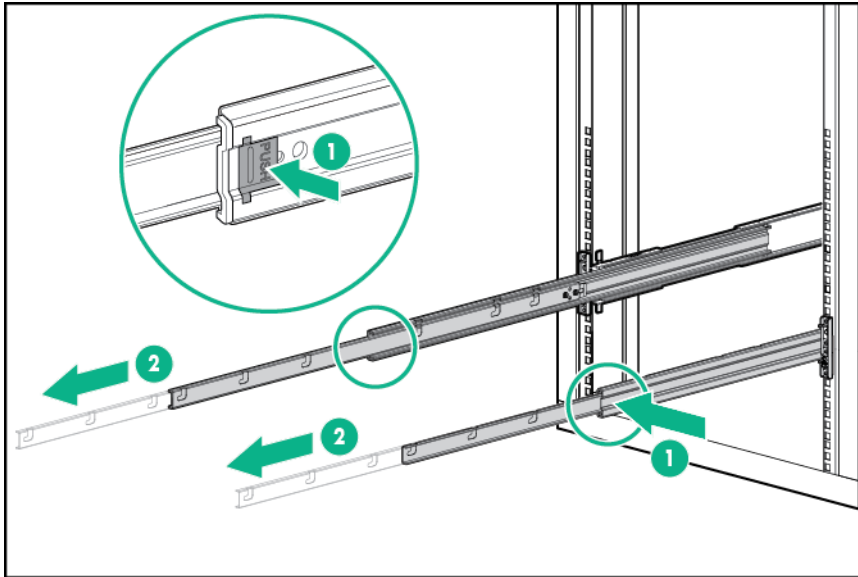

⚠ CAUTION: Be sure to keep the product parallel to the floor when installing the chassis. Tilting the product up or down could result in damage to the rails.

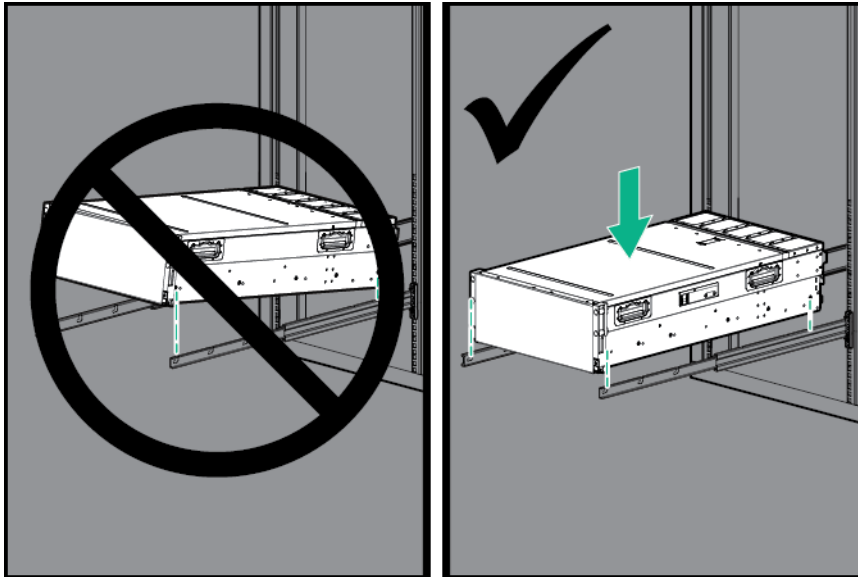

3. Install the chassis into the J-slot on the rails, and then pull it forward.

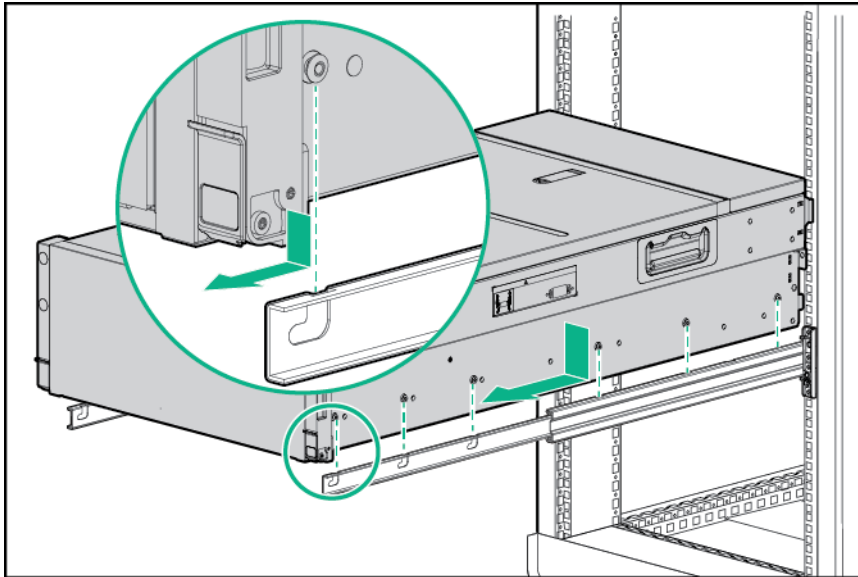

4. Press the Push tabs on each rail, and then slide the chassis into the rack. When the chassis stops midway, press the push tabs on each rail to release the chassis and slide it fully into the rack.

⚠ CAUTION: Press and hold the "Push" tab on each rail until the chassis begins to slide into the rack. Then, release the "Push" tabs and continue to slide the chassis into the rack. Press and hold the "Push" tab on each rail again when the rails lock at a 76.2-cm (30-inch) extension. Then, release the "Push" tabs again and finish sliding the chassis into the rack. Failure to release the "Push" tabs may cause damage to the rails.

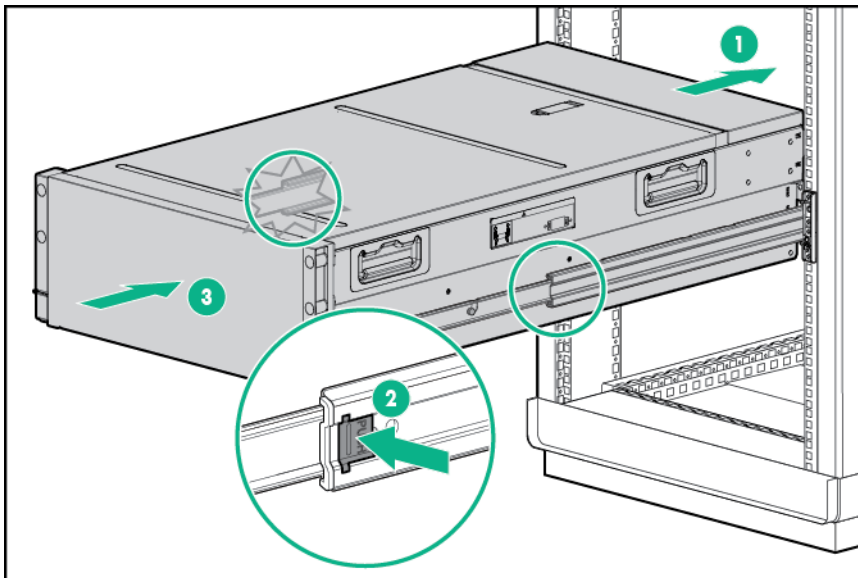

Installing the system components into the chassis

Once the chassis is installed in the rack, begin installing the components in the chassis.

Installing a server

⚠ CAUTION: To prevent improper cooling and thermal damage, do not operate the chassis unless all bays are populated with a component or a blank.

Procedure

1. Prepare the server for installation

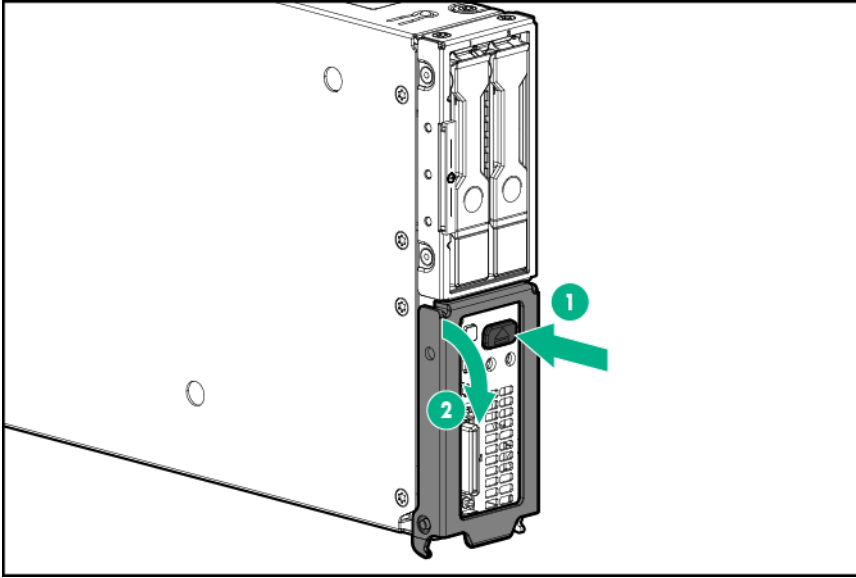

2. Install the server. When seated properly, the server will be flush with the front of the chassis and the release lever will close completely without resistance.

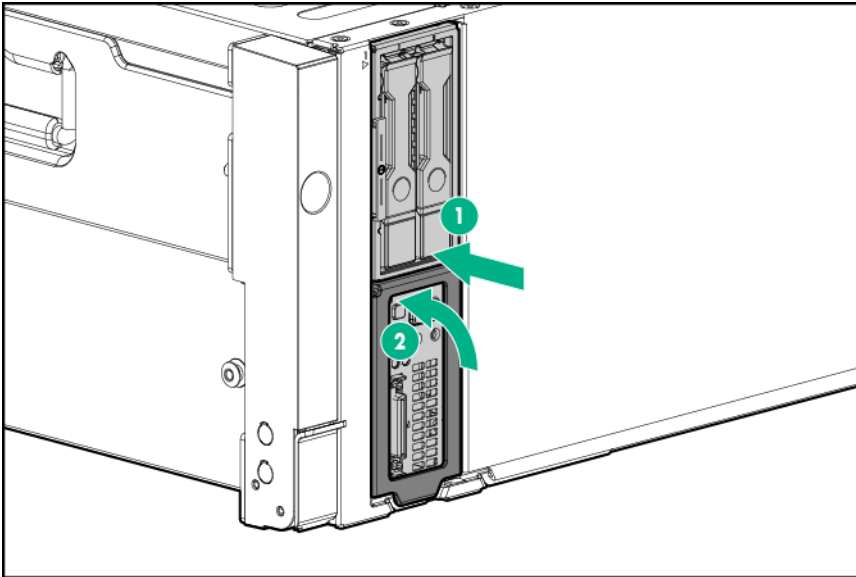

Installing a hot-plug drive

⚠ WARNING: To reduce the risk of injury from electric shock, do not install more than one drive carrier at a time.

Procedure

1. Remove the drive blank.
2. Prepare the low-profile LFF hot-plug drive for installation.

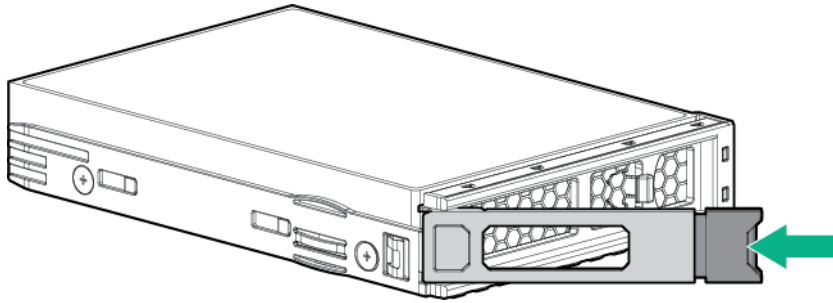

3. Install the LFF hot-plug drive in the chassis.



4. Determine the status of the drives using the drive LEDs located on the **storage display LEDs**.

To configure arrays, see the *HPE Smart Storage Administrator User Guide* on the Hewlett Packard Enterprise website (<http://www.hpe.com/info/smartstorage/docs>).

Installing a flex slot power supply



WARNING: To reduce the risk of electric shock or damage to the equipment:

- Do not disable the power cord grounding plug. The grounding plug is an important safety feature.
- Plug the power cord into a grounded (earthed) electrical outlet that is easily accessible at all times.
- Unplug the power cord from the power supply to disconnect power to the equipment.
- Do not route the power cord where it can be walked on or pinched by items placed against it. Pay particular attention to the plug, electrical outlet, and the point where the cord extends from the server.

Procedure

Install the component as indicated.

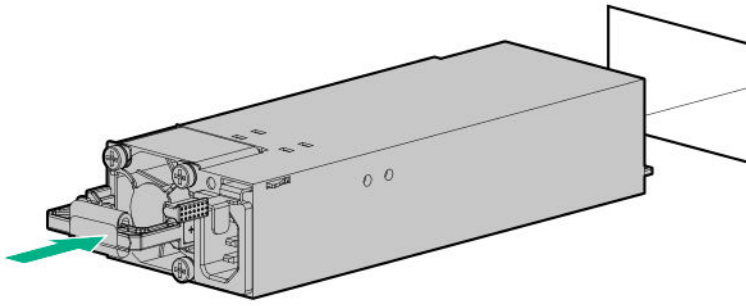

Installing the system fan

Procedure

1. To install a fan in bay 5, open the fan door. For all other fans, proceed to step 2.

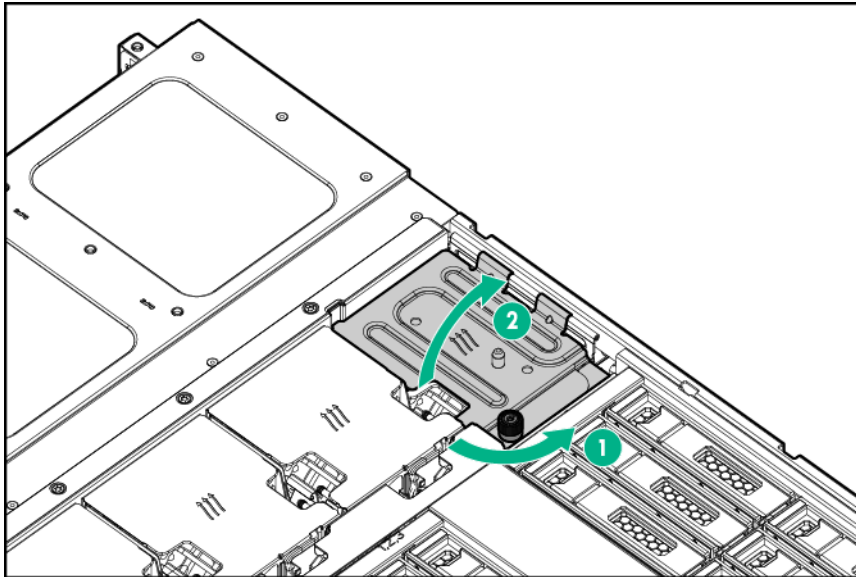

2. Push in on the tabs, and then insert the system fan into the chassis.

⚠ **IMPORTANT:** Use the tabs to insert the system fan into the chassis. Do not push in on the system fan grill to install it.

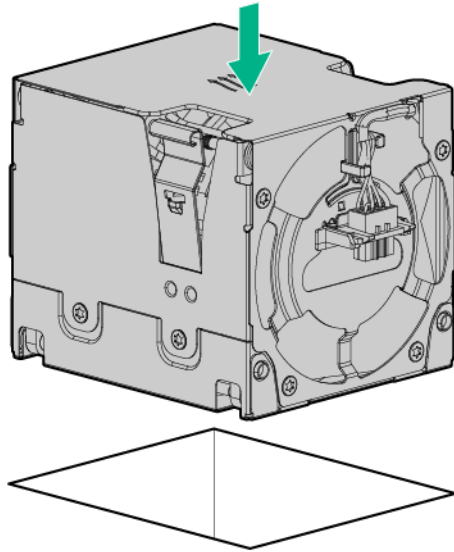

Installing a management module

Procedure

Install the component as indicated.

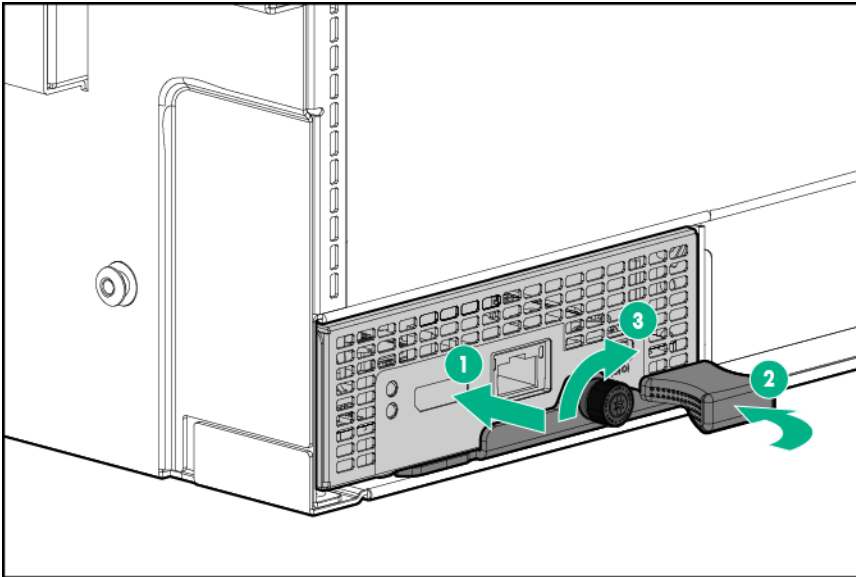

Installing the expansion board

Procedure

1. Remove the I/O module.

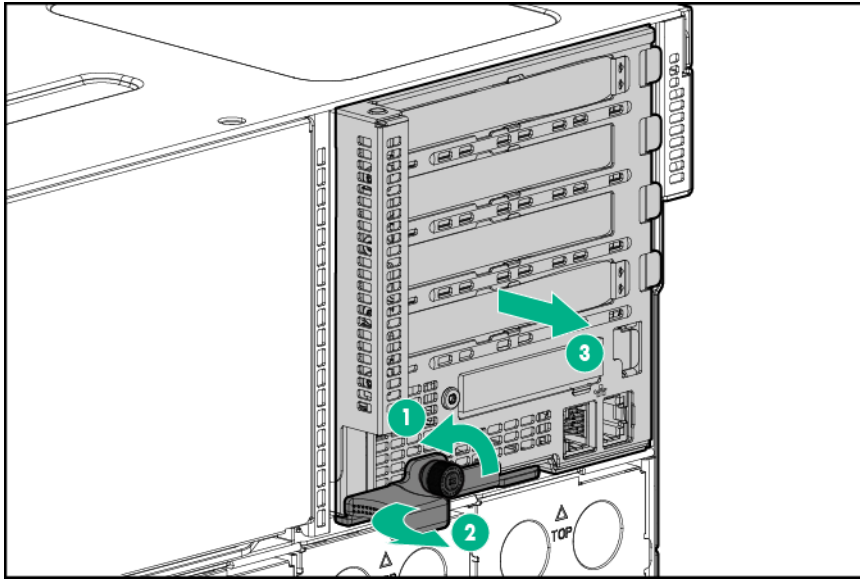

2. Remove the I/O module access panel.

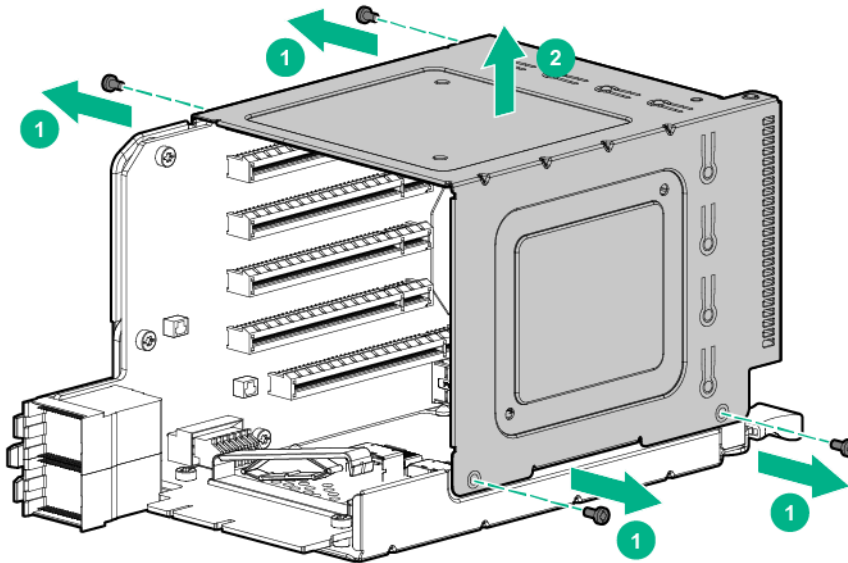

3. Remove the PCIe blank from the expansion slot.

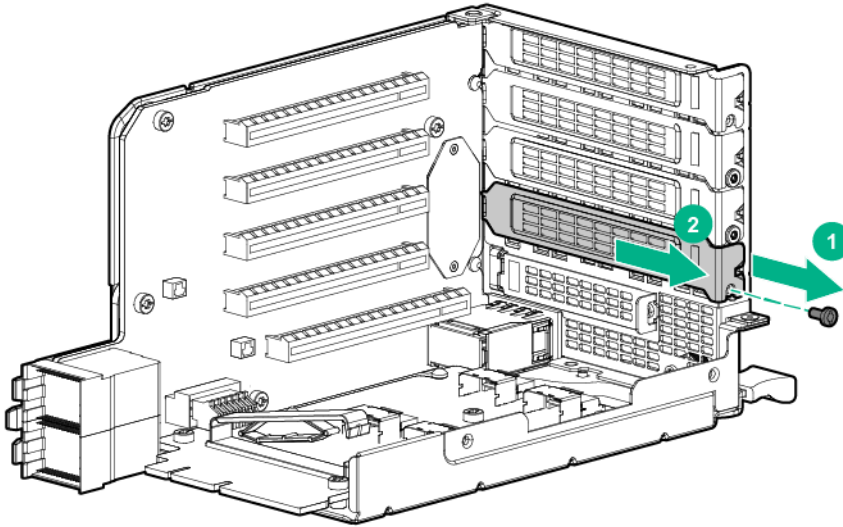

4. Install a supported expansion board option in one of the PCIe expansion slots.

Only slots 3 and 4 support HPE Smart Array Controllers.

If installing an expansion board option in an I/O module with the x16 riser option, be sure to install the x16 expansion board in PCIe slot 2. For more information, see the **"PCIe slot definitions (I/O module with x16 riser option)"**.

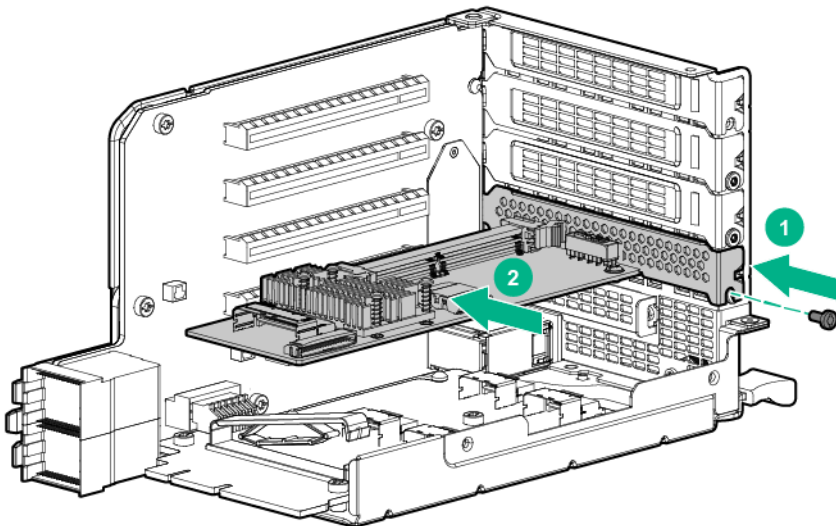

5. Cable the board according to the option installed. For more information, see **"I/O module option cabling."**

Installing an I/O module

Install any I/O module options before installing the I/O module into the chassis.

⚠ WARNING: To reduce the risk of electric shock, fire, or damage to the equipment, do not plug telephone or telecommunications connectors into RJ-45 connectors.

Procedure

Install the component as indicated.

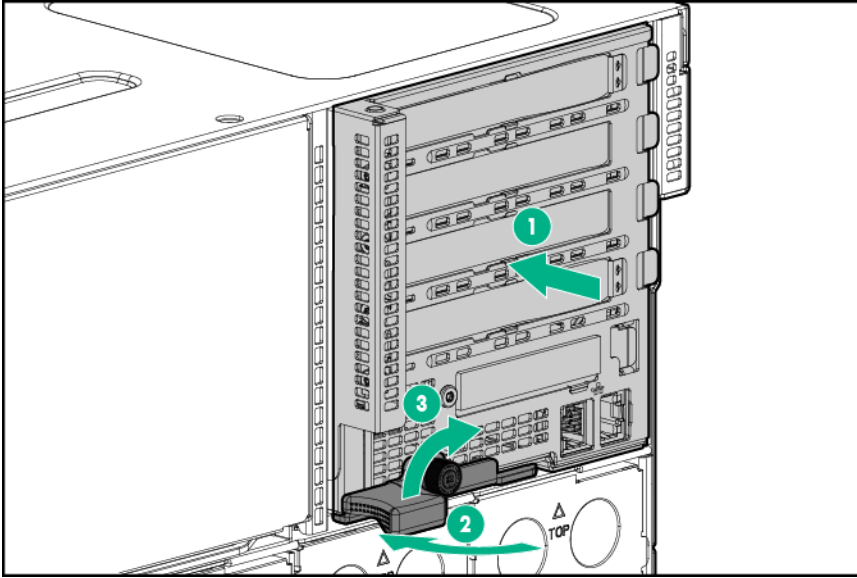

Installing the HPE Smart Storage Battery option

The HPE Apollo 4500 system with its centralized HPE Smart Storage Battery supports up to two HPE Smart Array controllers per node.

Procedure

1. Install the Smart Storage Battery.

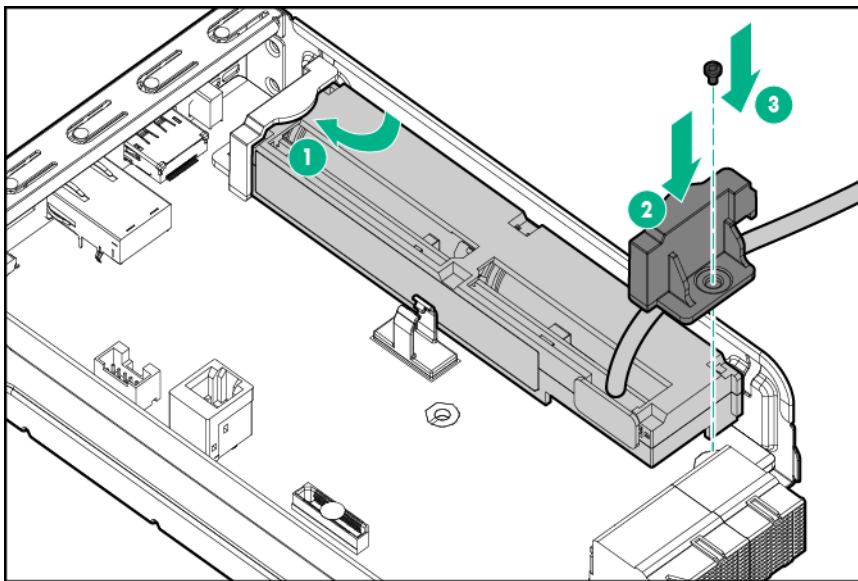

2. Connect the Smart Storage Battery cable to the Smart Storage Battery connector.

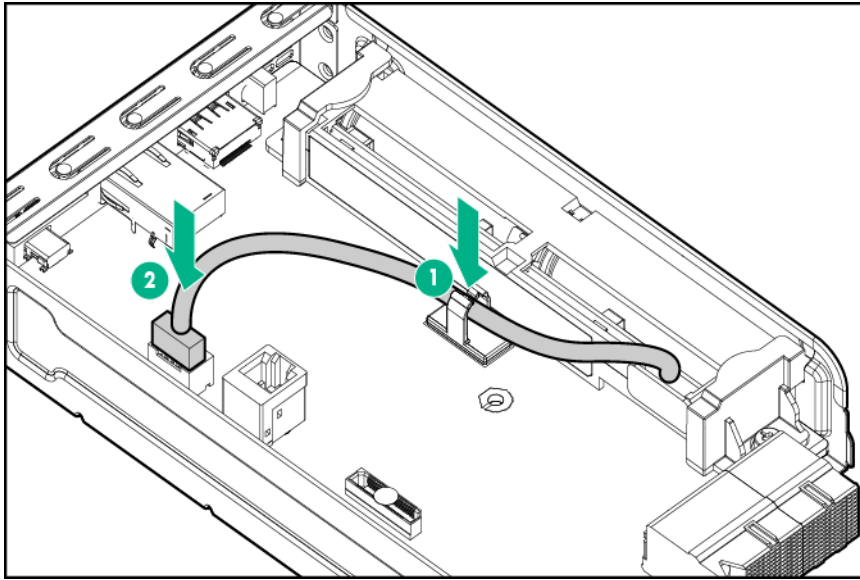

Cabling and powering up the chassis

Cabling the chassis

After all system hardware is installed, cable the components.

-
- ⚠ WARNING:** To reduce the risk of electric shock or injury due to high-current electrical energy, be sure that all power is completely disconnected at the source before beginning any power connections to the power bus bars or power bus box.
-
- ⚠ WARNING:** Be sure that all circuit breakers are locked in the off position before connecting any power components.
-
- ⚠ CAUTION:** To avoid damaging the fiber cables, do not drape cables from one side of the rack to the other and do not run cables over a hard corner or edge.
-

Procedure

1. Connect the network cables to the Ethernet ports on the I/O module (**I/O module components** on page 14).
2. Connect a network cable to the iLO connector on the management module (**Management module components** on page 13).
3. Connect the APM cable to the APM connector on the management module (**Management module components** on page 13).

Installing the cable management arm

-
- ⓘ IMPORTANT:** If you need to hinge the cable management arm on the rear right-hand side of the rack, see the instructions in **Converting the cable management arm for opposite side mounting**. Perform these steps to convert the arm to a right-hand swing and install the arm on the right side of the rack.
-

Procedure

1. Install the rack rail brace.

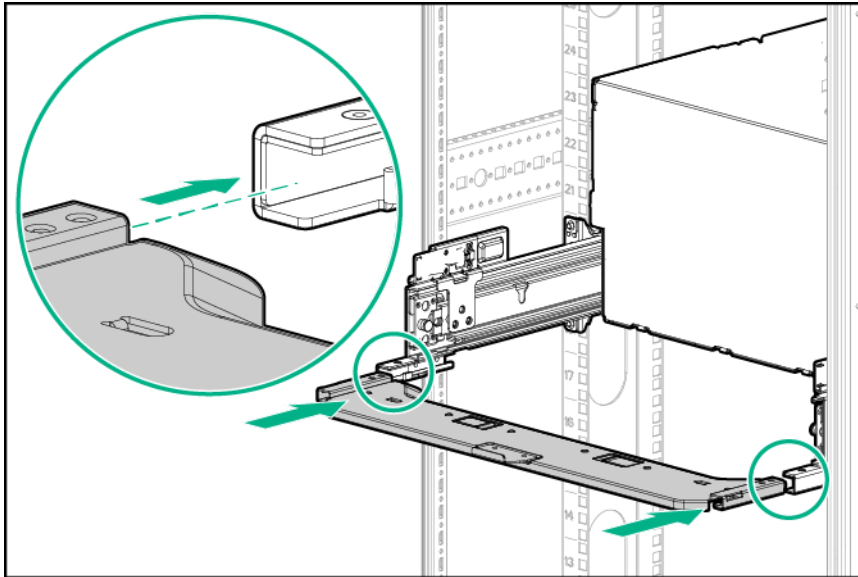

2. Align and install the cable management arm.

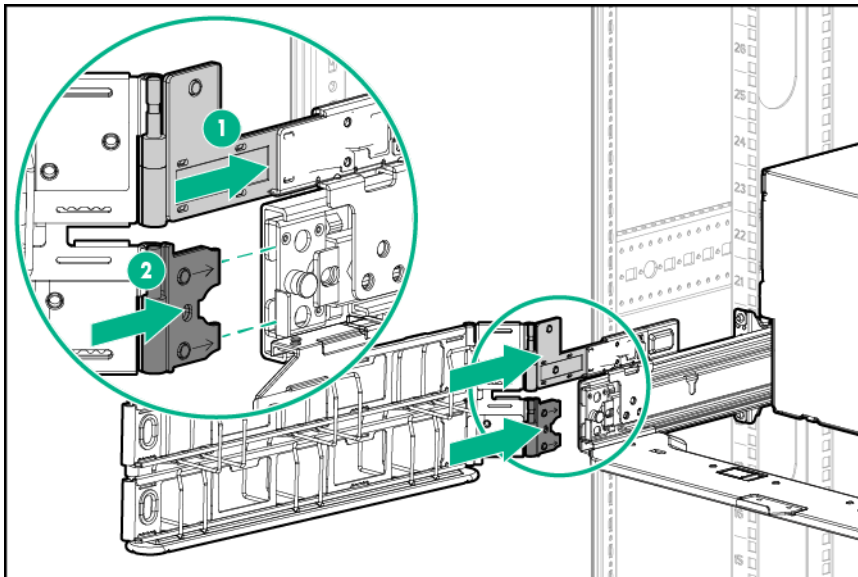

3. Press the latch and slide the cable management arm into place.

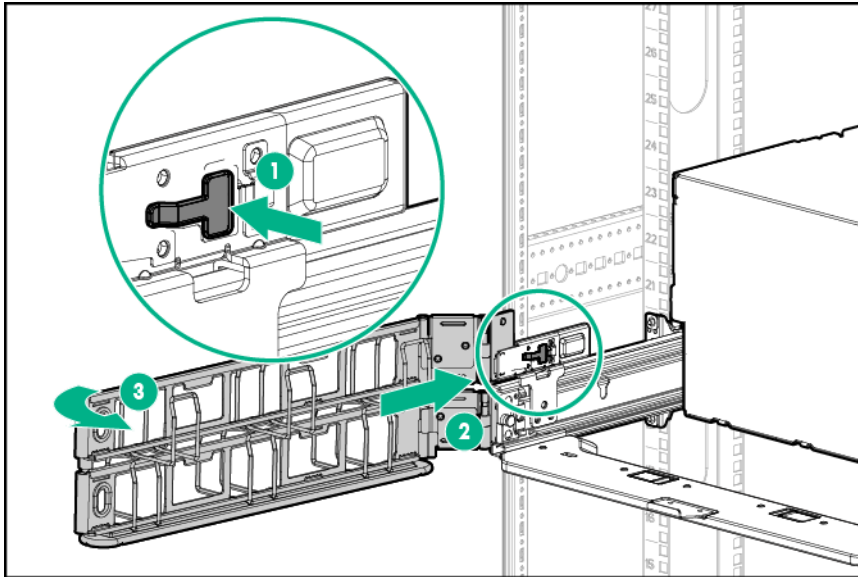

Converting the cable management arm for opposite side mounting

The cable management arm is designed for ambidextrous implementation. You can convert the arm for right-hand swing.

! **IMPORTANT:** When converting the cable arm, always be sure to orient the arm with the cable trough facing upward.

NOTE: To access some components on the rear of the product, you may need to remove the cable management arm.

Procedure

1. Press the latch to release the cable management arm and remove the cable management arm.

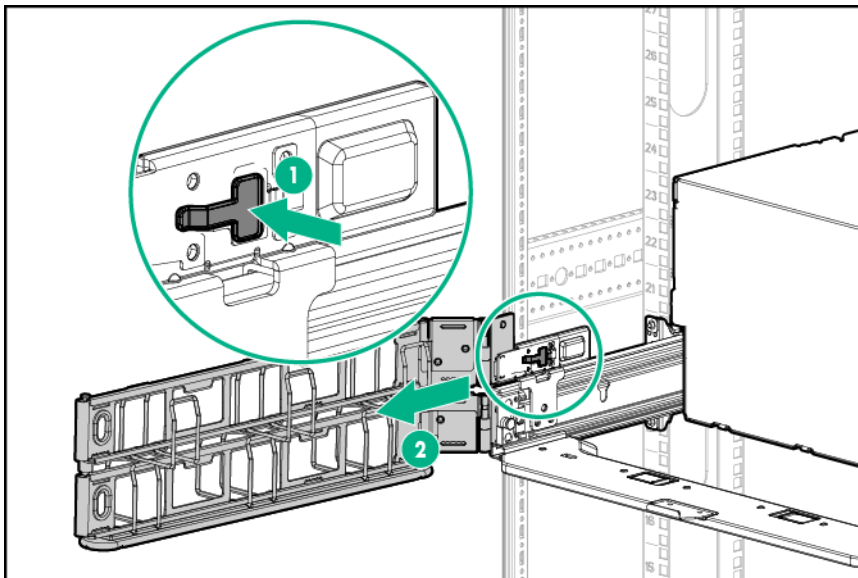

2. Move the cable management arm to the right rack rail and align the tab for opposite side mounting.

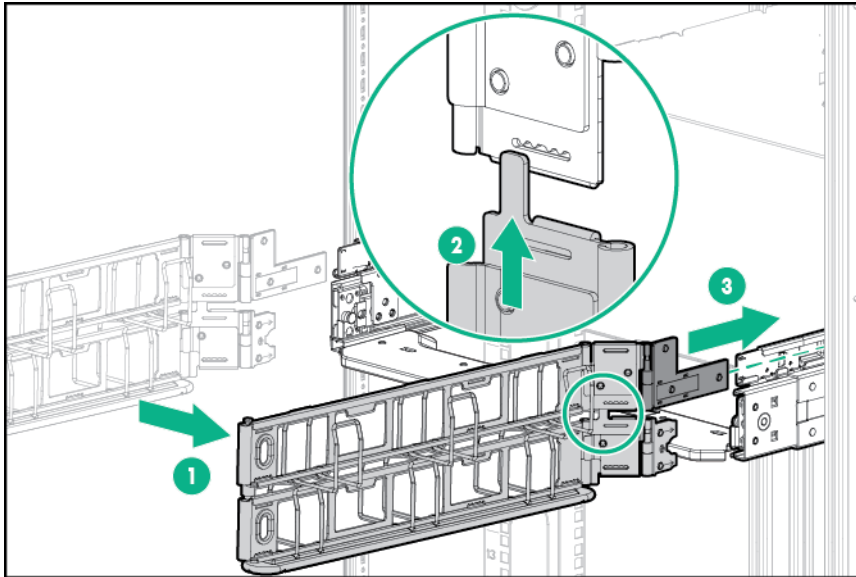

3. Align and install the cable management arm on the right rack rail.

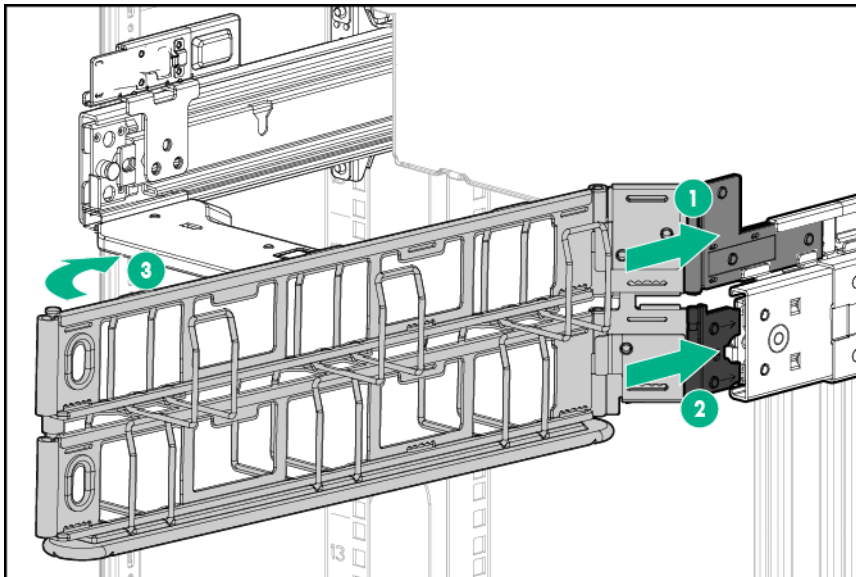

I/O module option cabling

The HPE Apollo 4500 system with its centralized HPE Smart Storage Battery supports up to two HPE Smart Array controllers per node.

When an I/O module with the x16 riser option is installed, PCIe slot 2 is reserved for x16 options and the HPE H240 Smart Host Bus Adapter options must be installed in PCIe slots 1 and 3.

This chassis supports one I/O module. Standard x8 I/O modules have four PCIe slots and one FlexibleLOM slot while x16 I/O modules have four PCIe slots. Each PCIe slot has a power connector. For power connector locations, see [I/O module power connector identification](#) on page 19.

This section describes the cable routing for the options installed in the I/O module.

HPE Smart Array P440 Controller cabling

The HPE Apollo 4510 Gen9 Chassis supports single and dual installation for the HPE Smart Array P440 Controller.

- Single-board option

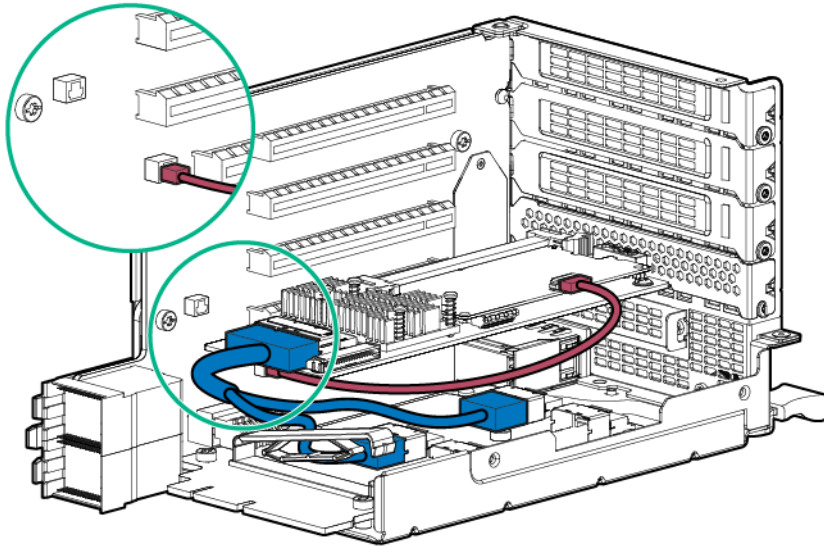

- Dual-board option

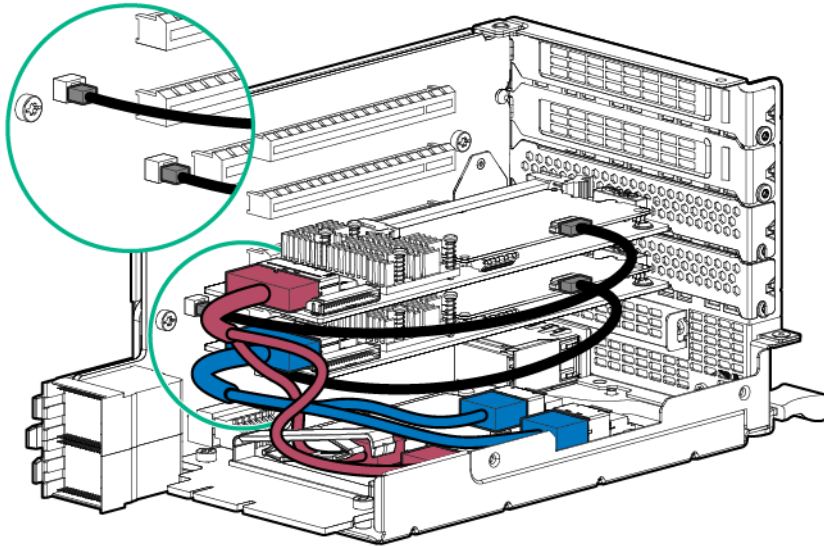

HPE Smart Array P840 Controller cabling

The HPE Apollo 4510 Gen9 Chassis supports single installation for the HPE Smart Array P840 Controller.

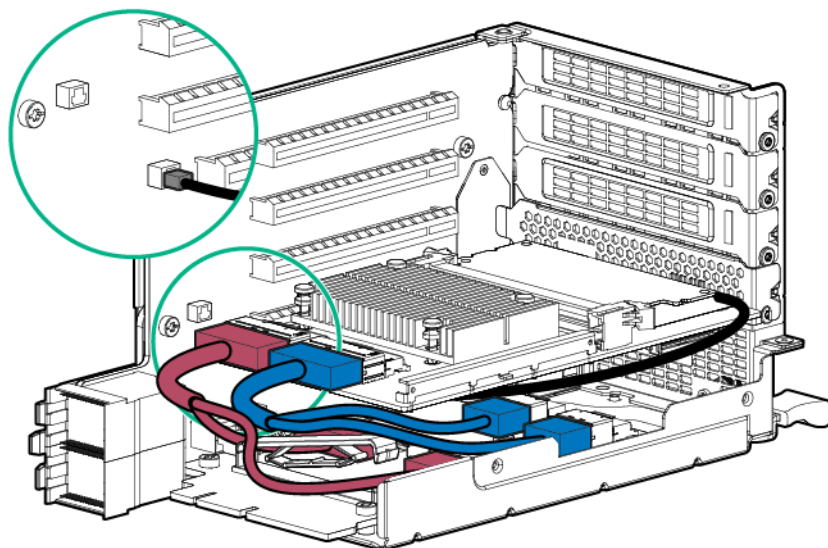

HPE H240 Smart Host Bus Adapter cabling

The HPE Apollo 4510 Gen9 Chassis supports single and dual installation for the HPE H240 Smart Host Bus Adapter.

- Single-board option

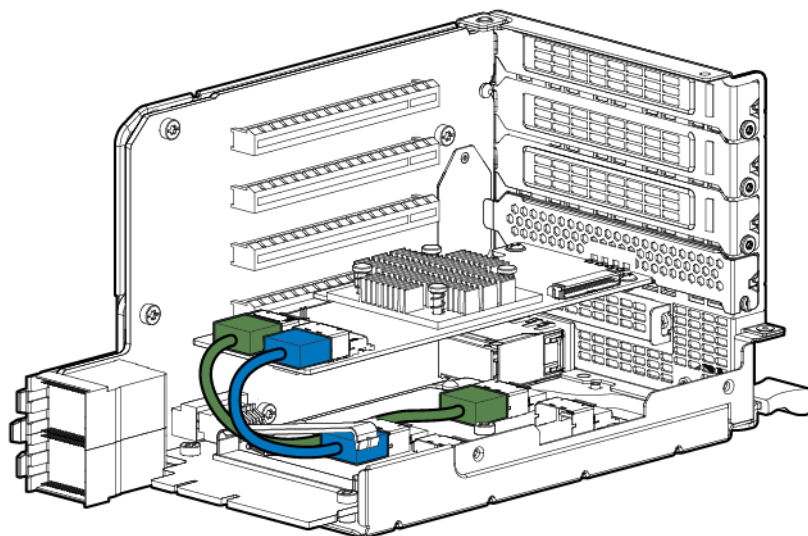

- Dual-board option

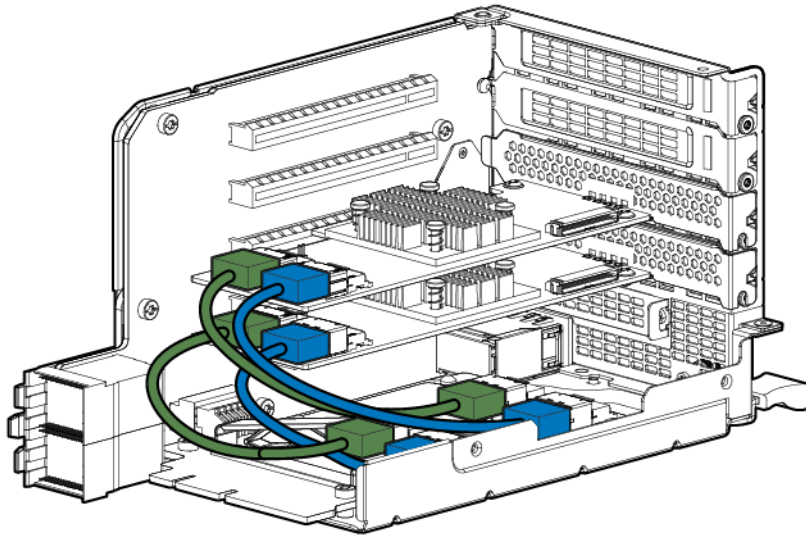

Powering up the system

Procedure

1. Connect the power cables to the power supplies.
2. Connect the power cables to the power source (UPS or wall outlet) or to an installed PDU.
3. Press the Power On/Standby button on the server.

Hot-plug power supply calculations

For hot-plug power supply specifications and calculators to determine electrical and heat loading for the server, see the Hewlett Packard Enterprise Power Advisor website (<http://www.hpe.com/info/poweradvisor/online>).

Power capping

The HPE ProLiant XL family of products provides a power capping feature that operates at the server enclosure level. The capping feature can be activated with PPIC.EXE, a stand-alone utility that runs in the environment of one of the resident servers in the chassis to be power capped. After a power cap is set for the enclosure, all the resident servers in the enclosure will have the same uniform power cap applied to them until the cap is either modified or canceled.

With HPE APM, the enclosure-level power capping feature can be expanded without the need to use the PPIC.EXE utility. A global power cap can be applied to all enclosures with one HPE APM command, or different caps can be applied to user-defined groups by using flexible zones within the same rack.

Power capping modes

The following Power Management modes are standard and are configurable in the power management controller:

- Mode 0: No Redundancy

All power-capping is disabled. This mode can be used to minimize any possible performance impact of power-capping logic.

- **Mode 1: Max Performance with Redundancy**

This is the default power capping mode. This mode allows the maximum number of nodes to run by engaging power-capping if the power draw from the chassis attempts to exceed the load supported by the active power supplies. In this mode, the system is expected to survive (with the possibility of degraded performance) an unexpected power loss to one or more of the power supplies.

- **Mode 2: Full AC/DC Redundancy Mode**

Power-capping is enforced such that system has N+1 power redundancy. In this mode, the system will throttle the nodes allowing for one of the available power supplies to be held in reserve. If only one power supply is available, the system will throttle the nodes as to allow the full use of that power supply's capacity.

- **Mode 3: User Configurable Mode**

The user can specify a valid power cap value from a pre-defined range. A cap cannot be set below a minimum or above a maximum. The cap includes all server nodes, fans, and drives. User configurable mode requires an iLO Scale Out or iLO Advanced license.

- **Mode 4: Rack Level Dynamic Power Capping Mode**

In conjunction with APM, the user can specify a maximum power capacity for the entire rack. The APM dynamically allocates power to the applicable chassis within the rack to maximize performance given the available power. For more information, see the *HPE Apollo Platform Manager User Guide* on the [Hewlett Packard Enterprise website](#).

- **Mode 5: Power Feed Redundancy Mode**

When used with an A+B power feed configuration, Power Feed Redundancy Mode throttles the system 100%, bringing the nodes to a complete stop if a power feed loss is deduced. Full throttling continues until the power feed is brought back online. In this mode, the system is expected to survive an unexpected loss of an entire power feed to half of the power supplies.

Configuring a power cap

To configure power capping, you can use the following utilities:

- **HPE ProLiant Power Interface Control Utility**

PPIC is a standalone utility that runs on a single server within the enclosure. For more information, see the *ProLiant Power Interface Control (PPIC) Utility User Guide* on the [Hewlett Packard Enterprise website](#).

- **Apollo Platform Manager**

HPE APM is a rack level device that can control power caps for all enclosures in the rack. For more information, see the *HPE Apollo Platform Manager User Guide* on the [Hewlett Packard Enterprise website](#).

Setting the chassis power cap mode with the PPIC utility

1. Download and install the ProLiant Power Interface Control Utility from the [Hewlett Packard Enterprise website](#).
2. Log in to the server, and then run the PPIC utility.
3. To set the power capacity mode, perform one of the following steps:

- To set mode 0, 1, and 2, enter the following command at the prompt:

```
-s -mmode
```

The following example sets the power capacity to mode 0:

```
-s -m0
```

- To set mode 3, enter the following command at the prompt:

```
-s -mmode -lpower
```

The following example sets the power capacity to mode 3 with a 1500W maximum power limit:

```
-s -m3 -l1500
```

Power capping modes show the valid values for `mode`. `Power` is required when setting Power Control Configuration to User Configurable.

For more information, see the *ProLiant Power Interface Control (PPIC) Utility User Guide* on the [Hewlett Packard Enterprise website](#).

Setting the chassis power cap mode with HPE APM

1. Log in to APM:

- a. When the system boots, a Login prompt appears.
- b. At the prompt, enter `Administrator`.

2. Before setting the power cap, enter the following command to review the power baseline:>`show power baseline`

The information displayed provides the minimum cap value, the maximum cap value, and the chassis that meet the requirements for power capping.

3. To set the power cap for eligible chassis connected to the APM, enter the following command at the prompt:>`SET POWER CAP<wattage>|NONE[zone_name]`

The wattage value, if provided, represents the total wattage to be allocated among all the chassis that are part of the baseline or partial baseline of a zone, if specified. This value is divided by the total maximum wattage established by the baseline to calculate a percentage cap value. This percentage is then multiplied against each chassis maximum wattage value to arrive at an appropriate cap value for that individual chassis.

If `NONE` is specified instead of a cap wattage value, then APM removes all (or the specified zone) of the power caps.

To remove baseline data from the EEPROM and to remove the power cap setting, enter the following command:

```
>SET POWER BASELINE NONE
```

After this command is issued, the only way to re-establish a power baseline is to issue the `SET POWER BASELINE` command. The system returns to the default power cap mode (mode 1).

Troubleshooting

Important safety information

Familiarize yourself with the safety information in the following sections before troubleshooting the server.



Important safety information

Before servicing this product, read the Important Safety Information document provided with the server.

Symbols on equipment

The following symbols may be placed on equipment to indicate the presence of potentially hazardous conditions.



This symbol indicates Hewlett Packard Enterprise systems and peripherals that contain assemblies and components that are sensitive to electrostatic discharge. Carefully observe the precautions and recommended procedures in this document to prevent component damage from static electricity.



This symbol indicates the presence of hazardous energy circuits or electric shock hazards. Refer all servicing to qualified personnel.

WARNING: To reduce the risk of injury from electric shock hazards, do not open this enclosure. Refer all maintenance, upgrades, and servicing to qualified personnel.



This symbol indicates the presence of electric shock hazards. The area contains no user or field serviceable parts. Do not open for any reason.

WARNING: To reduce the risk of injury from electric shock hazards, do not open this enclosure.



This symbol on an RJ-45 receptacle indicates a network interface connection.

WARNING: To reduce the risk of electric shock, fire, or damage to the equipment, do not plug telephone or telecommunications connectors into this receptacle.



This symbol indicates the presence of a hot surface or hot component. If this surface is contacted, the potential for injury exists.

WARNING: To reduce the risk of injury from a hot component, allow the surface to cool before touching.



99.79 kg

220.00 lb

This symbol indicates that the component exceeds the recommended weight for one individual to handle safely.

WARNING: To reduce the risk of personal injury or damage to the equipment, observe local occupational health and safety requirements and guidelines for manual material handling.



These symbols, on power supplies or systems, indicate that the equipment is supplied by multiple sources of power.

WARNING: To reduce the risk of injury from electric shock, remove all power cords to disconnect power from the system completely.

Troubleshooting resources

Troubleshooting resources are available for HPE ProLiant Gen9 servers in the following documents:

- The HPE ProLiant Gen9 Troubleshooting Guide, Volume I: Troubleshooting provides procedures for resolving common problems and comprehensive courses of action for fault isolation and identification, issue resolution, and software maintenance on ProLiant servers and server blades.
- The HPE ProLiant Gen9 Troubleshooting Guide, Volume II: Error Messages provides a list of error messages and information to assist with interpreting and resolving error messages on ProLiant servers and server blades.

To access the troubleshooting resources, see the Hewlett Packard Enterprise website (<http://www.hpe.com/info/Gen9-troubleshooting>).

Specifications

Environmental specifications

Specification	Value
Temperature range¹	
Operating	10°C to 35°C (50°F to 95°F)
Shipping	-40°C to 70°C (-40°F to 158°F)
Maximum wet bulb temperature	28°C (82.4°F)
Relative humidity (noncondensing)²	
Operating	10% to 90%
Nonoperating	5% to 95%

¹ All temperature ratings shown are for sea level. An altitude derating of 1°C per 300 m (1.8°F per 1,000 ft) to 3,048 m (10,000 ft) is applicable. No direct sunlight allowed.

² Storage maximum humidity of 95% is based on a maximum temperature of 45°C (113°F). Altitude maximum for storage corresponds to a pressure minimum of 70 kPa.

Chassis specifications

Specification	Value
Height	18.96 cm (7.46 in)
Depth	84.91 cm (33.43 in)
Width	44.33 cm (17.45 in)
Weight (fully loaded, with three XL450 servers)	99.79 kg (220.00 lb)
Weight, empty	43.09 kg (95.00 lb)

Power supply specifications

Depending on installed options, the server is configured with one of the following power supplies:

- **[HPE 800W Flex Slot Platinum Hot-plug Low Halogen Power Supply](#)** on page 51
- **[HPE 800W Flex Slot -48VDC Hot-plug Low Halogen Power Supply](#)** on page 51
- **[HPE 800W Flex Slot Titanium Hot-plug Low Halogen Power Supply](#)** on page 53
- **[HPE 800W Flex Slot Universal Hot-plug Low Halogen Power Supply](#)** on page 53
- **[HPE 1400W Flex Slot Platinum Plus Hot-plug Power Supply](#)** on page 54

For detailed power supply specifications, see the QuickSpecs on the Hewlett Packard Enterprise website (<http://www.hpe.com/info/proliant/powersupply>).

HPE 800W Flex Slot Platinum Hot-plug Low Halogen Power Supply

Specification	Value
Input requirements	—
Rated input voltage	100 VAC to 127 VAC 200 VAC to 240 VAC 240 VDC for China only
Rated input frequency	50 Hz to 60 Hz Not applicable to 240 VDC
Rated input current	9.1 A at 100 VAC 4.4 A at 200 VAC 3.6 A at 240 VDC for China only
Maximum rated input power	899 W at 100 VAC 867 W at 200 VAC 864 W at 240 VDC for China only
BTUs per hour	3067 at 100 VAC 2958 at 200 VAC 2949 at 240 VAC for China only
Power supply output	—
Rated steady-state power	800 W at 100 VAC to 127 VAC input 800 W at 100 VAC to 240 VAC input 800 W at 240 VDC input for China only
Maximum peak power	800 W at 100 VAC to 127 VAC input 800 W at 100 VAC to 240 VAC input 800 W at 240 VDC input for China only

HPE 800W Flex Slot -48VDC Hot-plug Low Halogen Power Supply

Specification	Value
Input requirements	—
Rated input voltage	-40 VDC to -72 VDC -48 VDC nominal input

Table Continued

Specification	Value
Rated input current	22.1 A at -40 VDC input
	18.2 A at -48 VDC input, nominal input
	12.0 A at -72 VDC input
Rated input power (W)	874 W at -40 VDC input
	865 W at -48 VDC input, nominal input
	854 W at -72 VDC input
Rated input power (BTUs per hour)	2983 at -40 VDC input
	2951 at -48 VDC input, nominal input
	2912 at -72 VDC input
Power supply output	—
Rated steady-state power (W)	800 W at -40 VDC to -72 VDC
Maximum peak power (W)	800 W at -40 VDC to -72 VDC
Maximum peak power	800 W at -40 VDC to -72 VDC input

⚠ WARNING: To reduce the risk of electric shock or energy hazards:

- This equipment must be installed by trained service personnel.
- Connect the equipment to a reliably grounded secondary circuit source. A secondary circuit has no direct connection to a primary circuit and derives its power from a transformer, converter, or equivalent isolation device.
- The branch circuit overcurrent protection must be rated 27 A.

⚠ CAUTION: This equipment is designed to permit the connection of the earthed conductor of the DC supply circuit to the earthing conductor at the equipment.

If this connection is made, all of the following must be met:

- This equipment must be connected directly to the DC supply system earthing electrode conductor or to a bonding jumper from an earthing terminal bar or bus to which the DC supply system earthing electrode conductor is connected.
- This equipment must be located in the same immediate area (such as adjacent cabinets) as any other equipment that has a connection between the earthed conductor of the same DC supply circuit and the earthing conductor, and also the point of earthing of the DC system. The DC system must be earthed elsewhere.
- The DC supply source is to be located within the same premises as the equipment.
- Switching or disconnecting devices must not be in the earthed circuit conductor between the DC source and the point of connection of the earthing electrode conductor.

HPE 800W Flex Slot Titanium Hot-plug Low Halogen Power Supply

Specification	Value
Input requirements	—
Rated input voltage	200 VAC to 240 VAC 240 VDC for China only
Rated input frequency	50 Hz to 60 Hz Not applicable to 240 VDC
Rated input current	4.35 A at 200 VAC 3.62 A at 240 VAC 3.62 A at 240 VDC for China only
Maximum rated input power	851 W at 200 VAC 848 W at 240 VAC 848 W at 240 VDC for China only
BTUs per hour	2905 at 200 VAC 2893 at 240 VAC 2893 at 240 VDC for China only
Power supply output	—
Rated steady-state power	800 W at 200 VAC to 240 VAC input 800 W at 240 VDC input for China only
Maximum peak power	800 W at 200 VAC to 240 VAC input 800 W at 240 VDC input for China only

HPE 800W Flex Slot Universal Hot-plug Low Halogen Power Supply

Specification	Value
Input requirements	—
Rated input voltage	200 VAC to 277 VAC 380 VDC
Rated input frequency	50 Hz to 60 Hz
Rated input current	4.4 A at 200 VAC 3.1 A at 277 VAC 2.3 A at 380 VDC

Table Continued

Specification	Value
Maximum rated input power	869 W at 200 VAC
	865 W at 230 VAC
	861 W at 277 VAC
	863 W at 380 VDC
BTUs per hour	2964 at 200 VAC
	2951 at 230 VAC
	2936 at 277 VAC
	2943 at 380 VDC
Power supply output	—
Rated steady-state power	800 W at 200 VAC to 277 VAC input
Maximum peak power	800 W at 200 VAC to 277 VAC input

HPE 1400W Flex Slot Platinum Plus Hot-plug Power Supply

Specification	Value
Input requirements	
Rated input voltage	200 to 240 VAC
	240 VDC for China only
Rated input frequency	50 Hz to 60 Hz
	Not applicable to 240 VDC
Rated input current	8.0 A at 200 VAC
	6.7 A at 240 VAC
	6.7 A at 240 VDC for China only
Maximum rated input power	1600 W at 200 VAC
	1600 W at 240 VAC
	1600 W at 240 VDC for China only
BTUs per hour	5459 at 200 VAC
	5459 at 240 VAC
	5459 at 240 VDC for China only
Power supply output	

Table Continued

Rated steady-state power	1400 W at 200 VAC to 240 VAC input 1400 W at 240 VDC input for China only
--------------------------	--

Maximum peak power	1400 W at 200 VAC to 240 VAC input 1400 W at 240 VDC input for China only
--------------------	--

Hot-plug power supply calculations

For hot-plug power supply specifications and calculators to determine electrical and heat loading for the server, see the Hewlett Packard Enterprise Power Advisor website (<http://www.hpe.com/info/poweradvisor/online>).

Environmental considerations

Communications interference

Hewlett Packard Enterprise system compliance tests are conducted with Hewlett Packard Enterprise supported peripheral devices and shielded cables, such as those received with the system. The system meets interference requirements of all countries in which it is sold. These requirements provide reasonable protection against interference with radio and television communications.

Installing and using the system in strict accordance with Hewlett Packard Enterprise instructions minimizes the chances that the system might cause radio or television interference. However, Hewlett Packard Enterprise does not guarantee that the system does not interfere with radio and television reception.

Take these precautions:

- Use only shielded cables.
- Install and route the cables according to the instructions provided.
- Ensure that all cable connector screws are firmly tightened.
- Use only Hewlett Packard Enterprise supported peripheral devices.
- Before system operation, ensure that all panels and cover plates are in place and secure.

Preventing electrostatic discharge

To prevent damaging the system, be aware of the precautions you must follow when setting up the system or handling parts. A discharge of static electricity from a finger or other conductor may damage system boards or other static-sensitive devices. This type of damage may reduce the life expectancy of the device.

Procedure

- Avoid hand contact by transporting and storing products in static-safe containers.
- Keep electrostatic-sensitive parts in their containers until they arrive at static-free workstations.
- Place parts on a grounded surface before removing them from their containers.
- Avoid touching pins, leads, or circuitry.
- Always be properly grounded when touching a static-sensitive component or assembly.

Grounding methods to prevent electrostatic discharge

Several methods are used for grounding. Use one or more of the following methods when handling or installing electrostatic-sensitive parts:

- Use a wrist strap connected by a ground cord to a grounded workstation or computer chassis. Wrist straps are flexible straps with a minimum of 1 megohm \pm 10 percent resistance in the ground cords. To provide proper ground, wear the strap snug against the skin.
- Use heel straps, toe straps, or boot straps at standing workstations. Wear the straps on both feet when standing on conductive floors or dissipating floor mats.

- Use conductive field service tools.
- Use a portable field service kit with a folding static-dissipating work mat.

If you do not have any of the suggested equipment for proper grounding, have an authorized reseller install the part.

For more information on static electricity or assistance with product installation, contact the **Hewlett Packard Enterprise Support Center**.

Websites

General websites

Hewlett Packard Enterprise Information Library

www.hpe.com/info/EIL

Subscription Service/Support Alerts

www.hpe.com/support/e-updates

Insight Remote Support

www.hpe.com/info/insightremotesupport/docs

For additional websites, see [Support and other resources](#).

Support and other resources

Accessing Hewlett Packard Enterprise Support

- For live assistance, go to the Contact Hewlett Packard Enterprise Worldwide website:
<http://www.hpe.com/assistance>
- To access documentation and support services, go to the Hewlett Packard Enterprise Support Center website:
<http://www.hpe.com/support/hpesc>

Information to collect

- Technical support registration number (if applicable)
- Product name, model or version, and serial number
- Operating system name and version
- Firmware version
- Error messages
- Product-specific reports and logs
- Add-on products or components
- Third-party products or components

Accessing updates

- Some software products provide a mechanism for accessing software updates through the product interface. Review your product documentation to identify the recommended software update method.
- To download product updates:
Hewlett Packard Enterprise Support Center
www.hpe.com/support/hpesc
Hewlett Packard Enterprise Support Center: Software downloads
www.hpe.com/support/downloads
Software Depot
www.hpe.com/support/softwaredepot
- To subscribe to eNewsletters and alerts:
www.hpe.com/support/e-updates
- To view and update your entitlements, and to link your contracts and warranties with your profile, go to the Hewlett Packard Enterprise Support Center **More Information on Access to Support Materials** page:
www.hpe.com/support/AccessToSupportMaterials

! **IMPORTANT:** Access to some updates might require product entitlement when accessed through the Hewlett Packard Enterprise Support Center. You must have an HPE Passport set up with relevant entitlements.

Customer self repair

Hewlett Packard Enterprise customer self repair (CSR) programs allow you to repair your product. If a CSR part needs to be replaced, it will be shipped directly to you so that you can install it at your convenience. Some parts do not qualify for CSR. Your Hewlett Packard Enterprise authorized service provider will determine whether a repair can be accomplished by CSR.

For more information about CSR, contact your local service provider or go to the CSR website:

<http://www.hpe.com/support/selfrepair>

Remote support

Remote support is available with supported devices as part of your warranty or contractual support agreement. It provides intelligent event diagnosis, and automatic, secure submission of hardware event notifications to Hewlett Packard Enterprise, which will initiate a fast and accurate resolution based on your product's service level. Hewlett Packard Enterprise strongly recommends that you register your device for remote support.

If your product includes additional remote support details, use search to locate that information.

Remote support and Proactive Care information

HPE Get Connected

www.hpe.com/services/getconnected

HPE Proactive Care services

www.hpe.com/services/proactivecare

HPE Proactive Care service: Supported products list

www.hpe.com/services/proactivecaresupportedproducts

HPE Proactive Care advanced service: Supported products list

www.hpe.com/services/proactivecareadvancedsupportedproducts

Proactive Care customer information

Proactive Care central

www.hpe.com/services/proactivecarecentral

Proactive Care service activation

www.hpe.com/services/proactivecarecentralgetstarted

Warranty information

To view the warranty information for your product, see the links provided below:

HPE ProLiant and IA-32 Servers and Options

www.hpe.com/support/ProLiantServers-Warranties

HPE Enterprise and Cloudline Servers

www.hpe.com/support/EnterpriseServers-Warranties

HPE Storage Products

www.hpe.com/support/Storage-Warranties

HPE Networking Products

www.hpe.com/support/Networking-Warranties

Regulatory information

To view the regulatory information for your product, view the *Safety and Compliance Information for Server, Storage, Power, Networking, and Rack Products*, available at the Hewlett Packard Enterprise Support Center:

www.hpe.com/support/Safety-Compliance-EnterpriseProducts

Additional regulatory information

Hewlett Packard Enterprise is committed to providing our customers with information about the chemical substances in our products as needed to comply with legal requirements such as REACH (Regulation EC No 1907/2006 of the European Parliament and the Council). A chemical information report for this product can be found at:

www.hpe.com/info/reach

For Hewlett Packard Enterprise product environmental and safety information and compliance data, including RoHS and REACH, see:

www.hpe.com/info/ecodata

For Hewlett Packard Enterprise environmental information, including company programs, product recycling, and energy efficiency, see:

www.hpe.com/info/environment

Documentation feedback

Hewlett Packard Enterprise is committed to providing documentation that meets your needs. To help us improve the documentation, send any errors, suggestions, or comments to Documentation Feedback (docsfeedback@hpe.com). When submitting your feedback, include the document title, part number, edition, and publication date located on the front cover of the document. For online help content, include the product name, product version, help edition, and publication date located on the legal notices page.

Acronyms and abbreviations

AC

alternating current

APM

advanced power management

CSA

Canadian Standards Association

CSR

Customer Self Repair

ESD

electrostatic discharge

IEC

International Electrotechnical Commission

iLO

Integrated Lights-Out

LFF

large form factor

LOM

LAN on Motherboard

PCIe

Peripheral Component Interconnect Express

PDU

power distribution unit

TMRA

recommended ambient operating temperature

UID

unit identification

UPS

uninterruptible power system

USB

universal serial bus