

Replaces: Goodman PCBBF136 and PCBBF140

FEATURES & SPECIFICATIONS

FEATURES

- Controls the gas valve, inducer draft motor, circulating blower and hot surface ignitor
- Monitors system pressure and limit switches
- Microprocessor based precision
- Twinning compatible with another ICM2810 control board
- Diagnostic LEDs aid in testing and troubleshooting
- Replaces: Goodman PCBBF136 and PCBBF140

TIMING

- Inducer Pre-Purge Time: 15 seconds
- Heat Blower ON Delay: 30 seconds
- Heat Blower OFF Delays: 90/120/150/180 seconds
- Cool Blower ON Delay: 5 seconds
- Cool Blower OFF Delay: 45 seconds
- Ignitor ON: 18 seconds
- Inducer Post Purge: 15 seconds
- Trials for Ignition: 3 (before soft lockout)
- Auto Reset: 60 minutes

ELECTRICAL

- Voltage Range: Line (98-132 VAC) @ 60Hz
- Cool Blower: 30A, 2 HP, 240 VAC
- Heat: 20A, 240 VAC
- Inducer Motor: 4A FLA, 8A LRA @ 120 VAC
- Ignitor: 10A FLA @ 120 VAC
- Humidifier: 5 amps @ 120 VAC
- Electric Air Cleaner: 5 amps @ 120 VAC

ENVIRONMENT

- Ambient Temperature
 - Operating: -40°F to 176°F
 - Storage: -40°F to 185°F
- Humidity: 5% to 95% R.H. (non-condensing) @ +55°F
- Vibration: 13.8Hz @ 0.2 Gs for one hour in each orthogonal axis

SAFETY CONSIDERATIONS

CAUTION! Only trained personnel should install or service heating equipment. When working with heating equipment, be sure to read and understand all precautions in the documentation, on labels, and on tags that accompany the equipment. Failure to follow all safety guidelines may result in damage to equipment, severe personal injury or death.

ELECTROSTATIC DISCHARGE (ESD) PRECAUTIONS

Use caution when installing and servicing the furnace to avoid and control electrostatic discharge. ESD can impact electronic components. These precautions must be followed to prevent ESD from hand tools and personnel. Following these precautions will protect the control from ESD by discharging static electricity buildup to ground.

1. Disconnect all power to the furnace. Do not touch the control or the wiring prior to discharging your body's electrostatic discharge to ground.
2. To ground yourself, touch your hand and tools to a clean, metal (unpainted) furnace surface near the control board.
3. Service the furnace after touching the chassis. Your body will recharge with static electricity as you shuffle your feet or move around, and you must reground yourself.
4. Reground yourself if you touch ungrounded items.
5. Before handling a new control, reground yourself; this will protect the control. Store used and new controls in separate containers before touching ungrounded objects.
6. ESD damage can also be prevented by using an ESD service kit.

INSTALLATION

Remove Existing Control:

1. Turn thermostat to OFF position or set it to the lowest possible setting.
2. Turn OFF electrical supply to furnace.

CAUTION! Failure to turn off gas and electric supplies can result in explosion, fire, death, or personal injury.

3. Label each wire with the correct terminal designation.
4. Disconnect the power supply and the thermostat lead wires from the existing ignition control.
5. Disconnect any other line/low voltage, accessory wire and ground leads from the existing ignition control.
6. Remove any screws and any other fasteners, and the old ignition board.

Install New Control:

1. Ground yourself properly before installing the new ICM2810 control board.
2. Mount the new control using any screws and fasteners previously removed.
3. Connect all line/low voltage, accessory, thermostat and ground wires.
4. Verify the sequence of operation.

Main Operation:

On the application of power, the control will continuously monitor the rollout switch, limit switch, pressure switch, gas valve output and flame sense. During a **Call for Heat**, the control makes sure the limit switch is closed and the pressure switch contact is open before turning on the Inducer blower, which will be energized for 15-seconds in a pre-purge mode. Following the pre-purge period, the pressure switch contact is closed and power is applied to the hot surface ignitor (there is a 18-second warm-up period). The gas valve is energized if a flame is sensed during this trial-for-ignition period, the blower motor will turn on following a 30-second delay. When the call for heat ends, the control will turn off the gas valve, the inducer blower will turn off after a 15-second post-purge period, and the heat blower will turn off after the jumper-selectable period of time (if jumper is missing, default Heat Blower Off delay is 120 seconds). During a **Call for Cool**, the control will energize the cool blower after a 5-second delay. When the call for cool ends, the control will turn the cool blower off after a 45-second delay.

Twining:

The ICM2810 is Twining compatible with another ICM2810 control board only. By connecting the designated "TWIN" screw terminals and the 24 VAC common together, the controls are designed to turn on/off the blower simultaneously and at the same speed. (NOTE: An external AC relay, whose coil is connected between R & W of the primary furnace and whose normally open contacts connect R & W of the secondary furnace, must be provided to cause both furnaces to heat). A common ground between the two furnaces is also required.

WIRING DIAGRAM

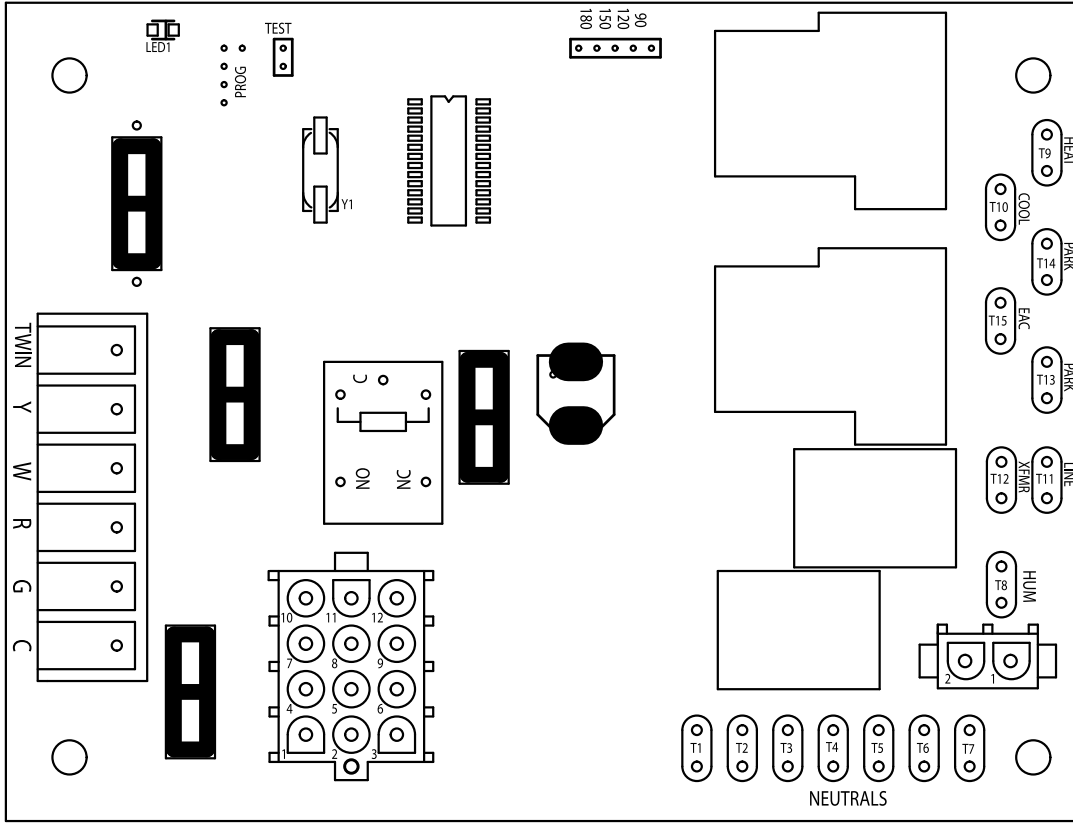
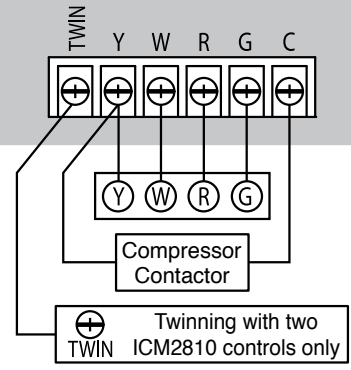
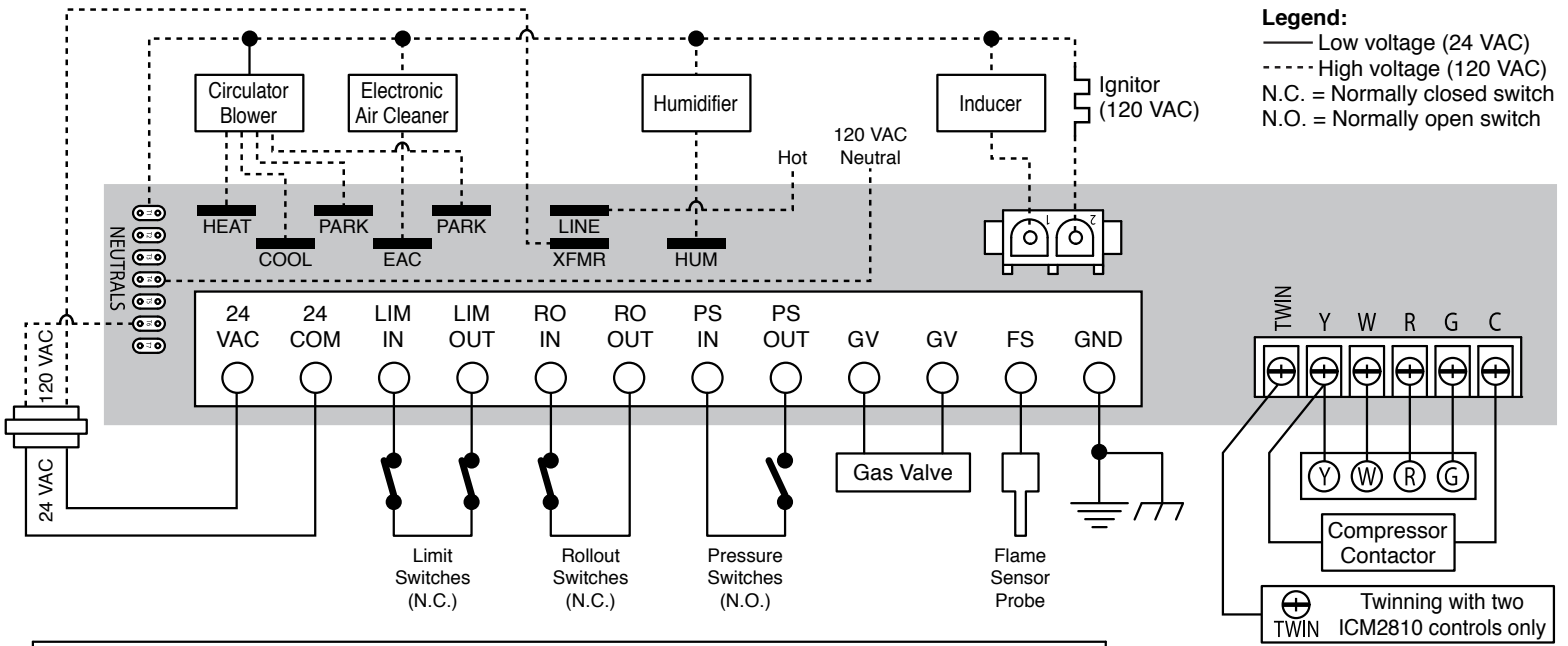

PIN CONNECTIONS

12-Pin Connections

Pin 1	Limit switch (W) (input)
Pin 2	Flame sense input
Pin 3	24 VAC input
Pin 4	Pressure switch (output)
Pin 5	Rollout switch (XFMR) (input)
Pin 6	Common
Pin 7	Limit switch (output)
Pin 8	Gas valve common
Pin 9	Common
Pin 10	Pressure switch (input)
Pin 11	Rollout switch (output)
Pin 12	Gas valve output

2-Pin Connections

Pin 1	Inducer blower
Pin 2	Hot surface ignitor

FAULT CODES

LED	FAULT CONDITION
ON	No fault
OFF	Control failure
1 flash	System lockout
2 flashes	Pressure switch stuck closed
3 flashes	Pressure switch stuck open
4 flashes	Open limit switch

LED	FAULT CONDITION
5 flashes	Flame has been sensed when no flame should be present
6 flashes	Open rollout switch
7 flashes	Low flame sense signal
8 flashes	C terminal must be grounded to frame of furnace or you have a faulty thermostat
Continuous Flashing	115 VAC AC power reversed