

ARBOR DINING CHAIR

Product Specification

Tom Raffield

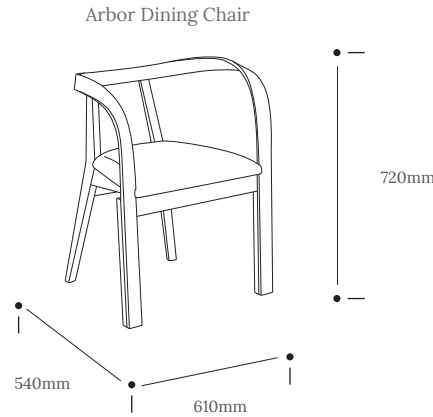

A powerful curve of steam bent wood bonds structure and aesthetic. Marrying Tom Raffield craftsmanship with Danish design principles, our Arbor Furniture Range defies nature with startling simplicity.

One length of sustainably sourced oak pushed to its limits. Three craftsmen simultaneously using all their skill to see the timber yield. A graceful tension. An inviting curve. A victory of design.

The Arbor Dining Chair perfectly pairs with the Treave Dining Table. Matching creativity with comfort — borrowing from nature then bending it beyond. Upholstered with 100% British wool.

Sit. Touch. Feel the craft under your fingers.

The Arbor Furniture Range also comes as an armchair and a sofa.

Product Type : Furniture	SKU	Wood types	Dimensions L x W x H (mm)		Weight (kg)	
			Unboxed	Boxed	Unboxed	Boxed
Arbor Dining Chair - Cobalt Blue	TR-ARB-DC-F-O-CB	Oak + Wool	610 x 540 x 720	565 x 630 x 830	6.8	9.35
Arbor Dining Chair - Canary Yellow	TR-ARB-DC-F-O-CY	Oak + Wool				
Arbor Dining Chair - Earth Silver	TR-ARB-DC-F-O-IPG	Oak + Wool				
Arbor Dining Chair - A Rum Fellow	TR-ARB-DC-F-O-ARF	Oak + A Rum Fellow fabric				
Arbor Dining Chair - Bespoke Fabric	TR-ARB-DC-F-O-BSP	Oak + Bespoke Fabric				
Materials	Oak	Canary Yellow wool	Earth Silver wool	Other Materials		
		Cobalt Blue wool	A Rum Fellow's Catarina Ikat Indigo	Bespoke fabric		
Finish	Finished with a blend of natural wax oils to give a protective, hardwearing and beautiful finish.					
Care information	<ul style="list-style-type: none"> Finish: The blend of natural oils can take up to four weeks to harden fully. Because of this, particular care should be taken in the first few weeks after delivery before cleaning, see below. Care: Solid wood may expand and shrink with differences in temperature and humidity so take care not to place your furniture directly next to anywhere with excessive changes in temperature such as radiators and windows. Cleaning: To clean on a regular basis wipe the surface with a damp cloth before removing any moisture with a dry cloth. Wipe off anything that will stain straight away, eg red wine, balsamic vinegar, oil, tea, coffee, alcohol, etc. In the event of severe spillages and stains the surface can be lightly re-sanded and re-oiled - please talk to us or a professional furniture restorer before doing so. We use high-quality British wool from Abraham Moon & Sons Ltd and regular care of the fabric following their full care guide will maintain its superior look. Our Canary Yellow fabric is from family-owned Linwood Fabrics. We recommend light vacuuming of fabric to remove dirt on a weekly basis, plus cleaning 2-3 times per year to preserve appearance. Commercial settings may require more frequent cleaning. Stains and spills should be cleaned up immediately with a clean cloth following Moon's care guide instructions. <ul style="list-style-type: none"> <i>Tom Raffield x A Rum Fellow collaboration</i> A Rum Fellow's Catarina Ikat Indigo Fabric: On fresh spills use a clean white and very lightly damp cloth to dab the spillage. Take care to avoid rubbing the fabric or making it wet which can spread the stain. Gentle blotting will stop the stain spreading and reduce the risk of it settling into the fabric. Do not use bleach or household products. For tougher stains please use a professional dry cleaning service. 					