

HANTER WALL LIGHT

Product Specification

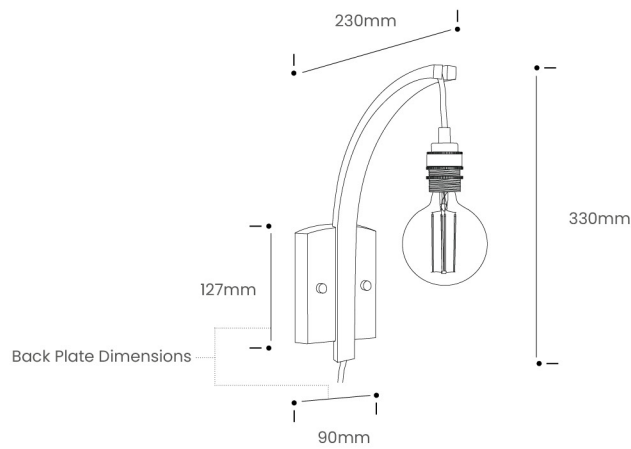



Tom Raffield

Hanter Wall Light



A taut arc of steam bent timber clings to a solitary filament bulb. Refreshing in its simplicity, surprising in its design, our Hanter Lighting Range turns heads. Sustainably sourced oak arches into a solid timber base. Along its curve, an exposed flex traces into a brass fitting, bringing a modern accent to a timeless, natural form.

Radiating light in all directions, the Hanter blends an inviting ambience with a sharp design aesthetic. Pair up. Create a feature. Make your mark. The Hanter Lighting Range is also available as a table light.

Product Type : Wall Light	SKU	Wood types	Dimensions L x W x H (mm)		Weight (kg)	
			Unboxed	Boxed	Unboxed	Boxed
Hanter Wall Light : Hardwired	TR-HAN-WL-O	Oak	90 x 230 x 330	540 x 312 x 165	0.45	1.45
Hanter Wall Light : Plug and switch	TR-HAN-WL-O-PLG	Oak				
Materials	Oak 				Other materials -	
Finish	Finished with a blend of natural wax oils to give a protective, hardwearing and beautiful finish.					
Wiring kit option : 1 Hardwired	Brass bulb holder with electrical connection block 	Wiring kit option 1 connection block included E27 (240v)	Flex Flex colour: grey fabric 	Recommended light bulb Max 25W LED		
Wiring kit option : 2 Plug and switch	Brass bulb holder with black inline switch and plug 	Wiring kit option 2 Plastic inline switch E27 (240v)	Flex Flex colour: grey fabric  Cable length: 228cm from plug to bulb holder	Recommended light bulb Max 25W LED		
Care information	Dusting your light regularly and with a light feather duster should keep your light looking clean, otherwise wipe with a damp cloth and remove any moisture with a dry cloth. Gentle furniture polishes can also be used.					
Additional information	<ul style="list-style-type: none"> Suitable for use on 240v circuits. Installation instructions and fixings included. This product can be plugged straight into a 240v outlet. If hardwiring into the main supply, this product must be installed by a qualified electrician. 					

Tom Raffield Ltd, F3 Church View Business Park, Bickland Water Rd, Falmouth TR11 4FZ, UK
tomraffield.com contact@tomraffield.com +44 (0) 1326 722725 #tomraffield @tomraffield

Due to the character of handcrafted natural products, all dimensions are approximate. Wood colour may slightly vary.
All products, prices and leadtimes are correct at time of print and are subject to change without notice.