

Cape Wall Light Installation Instructions

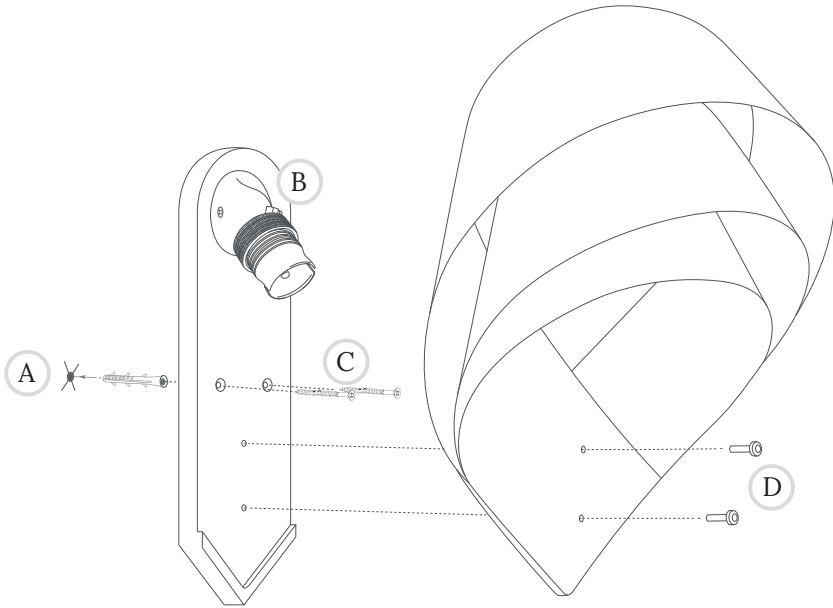

Only qualified persons should assemble the luminaire. If in doubt, consult a suitably qualified person. Installation MUST be carried out in accordance and compliance with current building regulations.

Ensure the electrical supply is turned OFF at the fuse board.

1. Identify if there are any hidden pipes or electrical cables in the wall to avoid causing damage or risk of electrical shock during installation. Hold the wooden backplate up to the chosen wall in the correct position and mark through the countersunk screw holes using a pencil (A). Drill two holes where you have marked and determine the fixing method appropriate to the wall structure. You may need additional fixings (e.g. plasterboard plugs).
2. Unscrew the brass ring cover (B) of the bulb holder to allow access to the terminals.
3. Connect the terminals in the brass bulb holder to the electricity supply (**220-240V AC 50-60Hz**) and screw the cover back on. Attach the back plate to the wall as detailed above using the countersunk head screws provided (C). Place the pointed part of the shade onto the lip of the back plate and push in the mini axle pegs provided (D). The pegs fit tightly so they may need to be gently tapped in.
4. Attach the light bulb included. The lampshade has been designed to work with a golf ball sized B22 **LED** light bulb, up to a maximum of **25 Watts**.
5. Turn the power supply on to complete installation.