

合格证

QC PASS

Godox

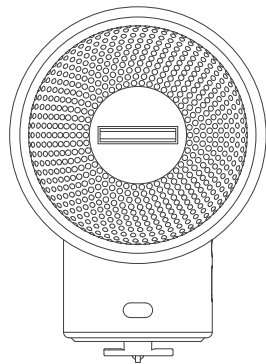

Wechat
Official Account

神牛微信公众号

深圳市神牛摄影器材有限公司

地址: 深圳市宝安区福海街道塘尾社区耀川工业区厂房2栋

电话: 0755-29609320(8062) 传真: 0755-25723423 邮箱: godox@godox.com

GODOX Photo Equipment Co.,Ltd.

Add.: Building 2, Yaochuan Industrial Zone, Tangwei Community, Fuhai Street, Bao'an District, Shenzhen 518103, China Tel: +86-755-29609320(8062) Fax: +86-755-25723423

E-mail: godox@godox.com

www.godox.com

Made in China | 705-LUXELF-00



LUX ELF

复古闪光灯

Retro Camera Flash

使用手册

Instruction Manual

说明书安全提示

重要安全提示

本产品属于专业摄影设备，需要专业人员操作使用。

使用时必须遵守以下基本安全预防措施：

使用前必须拆除产品上的所有运输保护材料和包装。

1. 使用本产品前，请仔细阅读并完全理解产品说明书，严格按照说明书中的安全提示操作。
2. 本产品为专业灯具，儿童禁止使用。儿童接近时，成人必须密切监督，防止儿童碰撞灯具或私自使用灯具，造成人身伤害。
3. 本灯具并非普通灯具，不可用于普通照明，任何有过眼部损伤或眼部敏感的人群均应避免使用本灯具或直视本灯具。
4. 使用时必须小心，严禁接触如闪光管等高温部件，以避免烫伤。
5. 任何情况下均禁止将闪光灯直接对准人眼（特别是婴儿眼睛），否则短时间内可能导致视力损伤。如感到眼睛不适，应立即关闭灯具，停止使用并及时就医。
6. 闪光管损坏时，应立即停止使用，及时联系制造商、服务代理商或合格维修人员更换，以防发生事故。
7. 严禁使用损坏的设备或配件，必须等待专业维修人员检查维修并确认设备正常后，才可继续使用。
8. 更换灯管、保护玻璃或保险丝前，必须断开电源或者拆下电池（如装有电池），确保灯具与电源完全断开。更换灯管前让其

冷却10分钟，操作时需戴绝缘/或隔热手套。

9. 使用过程中，如果产品因跌落、挤压或强力冲击导致外壳破裂，应立即停止使用，避免接触内部电子部件而触电受伤。
10. 在不使用时，请断开电源。
11. 本设备不防水，请保持干燥，不能浸入水或其他液体。应安装在通风干燥位置，避免在雨天、潮湿、多尘或过热环境中使用。不要在设备上方放置物品，或让液体流入内部，防止发生危险。
12. 未经授权，请不要自行拆卸本产品。产品若出现故障，必须由本公司或授权维修人员检查和维修。
13. 请勿将设备放置在酒精、汽油等易燃挥发性溶剂或气体如甲烷、乙烷等附近。
14. 本设备禁止在有爆炸危险的环境中使用或存放。
15. 请勿使用未经本公司认可的配件，以免造成火灾、触电或人身伤害。
16. 清洁设备时，请用干燥软布轻轻擦拭，不可使用湿布，否则可能会损坏设备。
17. 本使用说明基于严格测试制定，设计和规格变更恕不另行通知。您可登录我们官方网站查看最新电子版使用说明，了解产品最新资讯。

18. 产品内置锂电池，必须使用专用充电器充电，并按正确操作说明，在规定电压和温度范围内使用。
19. 产品使用锂电池供电。这类锂离子电池使用寿命有限，会逐渐失去储电能力，这种能力下降不可逆。电池老化时，产品续航时间会减少。锂离子电池使用寿命预计2—3年。请定期检查电池情况，如果充电时间明显增加或续航时间明显减少，请考虑更换新电池。
20. 处理任何电池前，请确认并遵守当地相关法律法规。
21. 本设备整机的保修期为一年。消耗品（如电池）、电源线等配件不在保修范围内。
22. 私自维修将取消保修资格，需支付维修费用。
23. 不当操作导致故障不在保修范围。

前言

感谢您购买神牛闪光灯Lux Elf。

Lux Elf,一款集极简主义和复古主义于一体的闪光灯。该闪光灯内置7.4V 350mAh锂电池，可实现高达400次闪光（全功率闪光）。通过全新设计的功率转盘，您可以轻松地调节闪光强度，在五个功率档位（1/16-1/1）之间自由选择，以适应不同的拍摄需求。底部采用单触点热靴设计，与各种相机机型完美兼容，只需插入即可实现同步触发，为您提供方便快捷的操作体验。

警告

- △ 请保持产品干燥。
- △ 请勿将闪光灯头正对人眼闪光（特别是婴儿的眼睛），否则可能会在短时间内造成视力障碍。
- △ 请勿在化学品、可燃性气体或其他特殊物质附近使用闪光灯，这些物质在特殊情况下可能对闪光灯发出的瞬间强光敏感，有可能导致火灾或电磁干扰。在这些场合下，请注意相关警告标识。
- △ 本产品不能防水，在雨天及潮湿环境下请注意防水。

部件名称

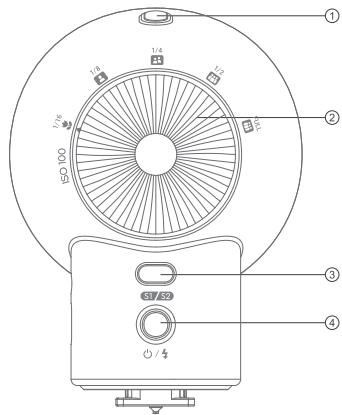

1. 光控传感器
2. 功率转盘
3. S1/S2按键
4. 开关按键/试闪按键/回电指示灯

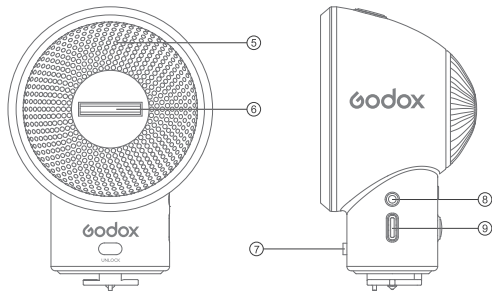

5. 反光罩
6. 闪光灯管
7. 拆卸按钮
8. 同步孔
9. USB-C充电口
10. 热靴

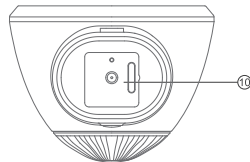

回电指示灯说明

在开机状态下

1. 当回电指示灯呈现常亮红色状态，表示正在回电；
2. 当回电指示灯呈现常亮绿色状态，表示回电结束；
3. 当回电指示灯呈现均匀闪烁红色状态，表示电池处于低电量，这种情况下，请及时充电；
4. 当回电指示灯呈现急促闪烁状态，表示该灯处于高温报警状态；
5. 当回电指示灯呈现不发亮状态，表示电池没电。

在关机状态下

1. 回电指示灯呈现常亮红色状态，表示正在充电；
2. 回电指示灯呈现常亮绿色状态，表示充电完成；
3. 回电指示灯呈现急促闪烁状态，表示当前充电温度过高，电池停止充电。（电池充电温度范围为 0°C-45°C）

在关机状态下，短按一次回电指示灯可检查电量

1. 回电指示灯变为绿灯且闪烁4次，表示当前电量为75-100%；
2. 回电指示灯变为绿灯且闪烁3次，表示当前电量为电量50-75%；
3. 回电指示灯变为绿灯且闪烁2次，表示当前电量为电量25-50%；
4. 回电指示灯变为红灯且闪烁1次，表示当前电量为电量0-25%，请及时充电。

物品清单

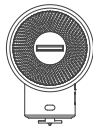

复古闪光灯
× 1



USB-C 充电线
× 1



收纳包
× 1



说明书
× 1

温馨提示：

说明书中的图片均为示意图，仅供参考。由于产品不断更新与升级，产品实物与图片可能存在差异，请以实物为准。

开机/关机

长按开关按键即可开机/关机。

注：待相机装上闪光灯后，方可开启相机和闪光灯。

功率档位选择

该灯共有5档功率档位：1/16、1/8、1/4、1/2、Full。

您可根据相机感光度ISO值和拍摄距离，简单转动转盘调整所需的功率档位。

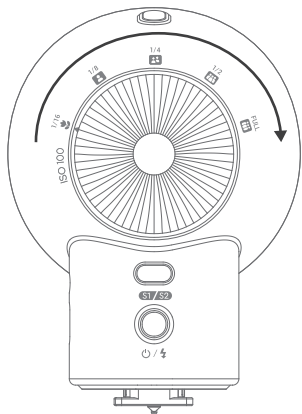

注：由神牛实验室测试得出，在相机感光度ISO 100，拍摄距离1m时，闪光灯闪光指数为GN6，您可根据以下使用表，结合自身的拍摄参数，自行调节闪光灯功率档位。

实用表

拍摄距离(m) GN值	光圈						
	2	2.8	4	5.6	8	11	16
24	12	8.5	6	4.2	3	2.1	1.5
17	8.5	6	4.2	3	2.1	1.5	1.1
12	6	4.2	3	2.1	1.5	1.1	0.8
8.4	4.2	3	2.1	1.5	1.1	0.8	0.5
6	3	2.1	1.5	1.1	0.8	0.5	0.4
4.2	2.1	1.5	1.1	0.8	0.5	0.4	0.3
3	1.5	1.1	0.8	0.5	0.4	0.3	0.2
2.1	1.1	0.8	0.5	0.4	0.3	0.2	0.1
1.5	0.8	0.5	0.4	0.3	0.2	0.1	0.08
1.05	0.5	0.4	0.3	0.2	0.1	0.08	0.07

GN值 闪光 功率	感光度	50	100	200	400	800	1600
	1 (full)		4.2	6	8.4	12	17
1/2		3	4.2	6	8.4	12	17
1/4		2.1	3	4.2	6	8.4	12
1/8		1.5	2.1	3	4.2	6	8.4
1/16		1.1	1.5	2.1	3	4.2	6

光控模式

S1光控模式设置

短按S1/S2按键令按键呈现红色状态，此刻闪光灯处于S1光控模式，闪光灯可作为副灯使用，创造多种照明效果，适用于手动闪光环境。它会与主闪光灯的第一次闪光同步触发闪光，效果与使用无线引闪器一致。

S2光控模式设置

短按S1/S2按键令按键呈现蓝色状态，此刻闪光灯处于S2光控模式，闪光灯可作为副灯使用，适用于TTL闪光环境；具有防预闪功能，使用带一次预闪功能的相机能用光控实现同步拍摄。它会与主闪光灯的第二次闪光同步触发闪光，即2次光控引闪。

规格参数

型号	Lux Elf
闪光指数 (1/1 档位)	GN6 (ISO100, 以米为单位)
内置锂电池	7.4V  350mAh
USB - C口输入	5V  2A
闪光功率档位	5 档: 1/16—FULL
色温	6000K \pm 200K
光控引闪	S1 光控同步引闪/S2 光控防预闪引闪
工作环境温度	-10°C ~ 50°C
回电时间 (1/1 档位)	\approx 3.6s
闪光次数 (1/1 档位)	\approx 400次
电池充电温度范围	0°C-45°C
同步触发	热靴, 同步线
尺寸	70mm \times 97mm \times 53mm
净重 \approx	96g

规格和参数如有变更, 恕不另行通知。

Important Safety Instructions

This product is a professional photographic equipment, to be operated by professional personnel only.

The following basic safety precautions must be followed when using this product:

All transport protective materials and packaging on the product must be removed before use.

1. Carefully read and fully understand the instruction manual before use and strictly follow the safety instructions.
2. This product is a professional lighting fixture, children are prohibited from using it. Children must be closely supervised by adults when approaching the fixture, to prevent collisions with the fixture or unauthorized use that could cause personal injury.
3. This is not an ordinary lighting fixture and must not be used for general illumination. Anyone with a history of eye damage or sensitivity should avoid using this fixture or looking directly at it.
4. Extreme caution must be exercised when using it, do not touch high-temperature parts such as flash tubes to avoid burns.
5. Do not point the flash directly at the eyes (especially baby's

eyes) under any circumstances, as this could impair vision in a short time. Turn off immediately if discomfort occurs, stop using, and seek medical attention promptly.

6. If the flash tube is damaged, stop using it immediately and contact the manufacturer, service agent, or qualified repair personnel for a replacement to prevent accidents.
7. Do not use damaged equipment or accessories. Allow professional repair technicians to inspect and confirm normal operation before continuing use after repairs.
8. Disconnect power source or remove batteries (if it has one) before replacing flash tube, protective glass, or fuses. Allow 10 minutes to cool before replacing flash tube, and wear insulated or heat resistant gloves when operating.
9. Stop using immediately if the product shell is cracked due to falling, squeezing, or strong impact, to avoid touching the internal electronic components and getting an electric shock.
10. Please disconnect the power when not in use.
11. This device is not waterproof. Keep it dry and avoid immersing it in water or other liquids. It should be installed in a ventilated and dry location and avoid using in rainy, humid, dusty, or overheated environments. Do not place

items above the device or allow liquids to flow into it to prevent danger.

12. Do not disassemble without authorization. If the product malfunctions, it must be inspected and repaired by our company or authorized repair personnel.
13. Do not place the device near alcohol, gasoline, or other flammable volatile solvents or gases such as methane and ethane.
14. Do not use or store this device in potentially explosive environments.
15. Do not use accessories not been approved by our company, as this may cause fire, electric shock or personal injury.
16. Clean gently with a dry cloth. Do not use a wet cloth as it may damage the device.
17. This instruction manual is based on rigorous testing. Changes in design and specifications are subject to change without notice. Check official website for latest instruction manual and product updates.
18. Use only specified charger and follow proper usage instructions for the products with built-in lithium batteries, within the rated voltage and temperature range.
19. The products are powered by lithium batteries, who have

limited lifespans and will gradually lose their charging capacities, which is irreversible. As the battery ages, the product's battery life will decrease. The lifespan of lithium battery is estimated to be 2 to 3 years. Please regularly check the battery, and if the charging time significantly increases or the battery life significantly decreases, consider replacing the battery.

20. Confirm and comply with all relevant local laws and regulations when handling any batteries.
21. The warranty period for this device as a whole is one year. Consumables (such as batteries), power cords, and other accessories are not covered by the warranty.
22. Unauthorized repairs will void the warranty and will incur charges.
23. Failures from improper operation is not covered under warranty.

Foreword

Thank you for purchasing!

Lux Elf, a flash unit that seamlessly combines minimalist design with a retro style. The built-in 7.4V 350mAh lithium battery allows you to enjoy extended creative sessions. Operating at full power, it offers up to 400 flashes, ensuring long-lasting durability. Its unique adjust dial design enables you easily switch among five power steps (1/16-1/1) to precisely control the intensity of light. The legacy hot shoe is seamlessly compatible with all camera brands, providing hassle-free synchronization with a simple plug-in, so that you can focus fully on creativity without interruptions.

Warning

- ⚠ Always keep this product dry.
- ⚠ Do not fire the flash directly into the eyes (especially those of babies) within short distances. Otherwise, visual impairment may occur.
- ⚠ Do not use the flash unit in the presence of flammable gases, chemicals and other similar materials. In certain circumstance, these materials may be sensitive to the strong light emitting from this flash unit and fire or electromagnetic interference may result.
- ⚠ As the device do not have waterproof function, do not use in rain or in damp conditions.

Names of Parts

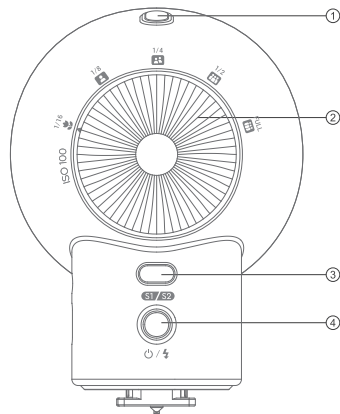

1. Optical Sensor
2. Power Adjust Dial
3. S1/S2 Button
4. Power Switch/Test Button/Recycle Indicator

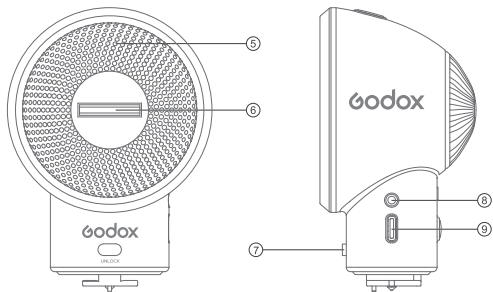

- 5. Reflector
- 6. Flash Tube
- 7. Detaching Button
- 8. Sync Hole
- 9. USB-C Charging Port
- 10. Hot Shoe

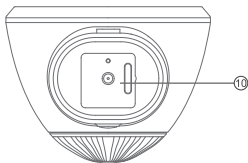

Recycle Indicator Instruction

Power On status

1. When the recycle indicator is constant on red, it means recycling.
2. When the recycle indicator is constant on green, it means recycle complete.
3. When the recycle indicator flashes red stably, it means low battery state, please charge the battery in time.
4. When the recycle indicator flashes rapidly, it means high temperature state.
5. When the recycle indicator is off, it means battery is dead.

Power Off status

1. When the recycle indicator is constant on red, it means charging.
2. When the recycle indicator is constant on green, it means charging complete.
3. When the recycle indicator flashes rapidly, it means battery over-temperature and stops charging. (battery charging temperature range: 0°C-45°C)

Short press the recycle indicator once to check battery level in power off status

1. The recycle indicator turns to green and blinks four times, it means 75%–100% battery level.
2. The recycle indicator turns to green and blinks three times, it means 50%–75% battery level.
3. The recycle indicator turns to green and blinks twice, it means 25%–50% battery level.
4. The recycle indicator turns to green and blinks once, it means 0–25% battery level, please charge the battery in time.

What's Inside

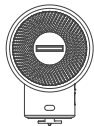

Retro Camera Flash
x 1



USB-C Charging Cord
x 1



Storage Bag
x 1



Instruction
Manual
x 1

Note: Due to continuous updates and upgrades of the products, there may be differences between the actual products and the pictures. Therefore, the pictures are for reference only, products to prevail in kind.

Power Switch

Press and hold the power switch to turn on or off the flash.

Note: Install the flash to the camera then turn on the camera and flash.

Power Settings

Five steps of adjustable power: 1/16, 1/8, 1/4, 1/2, Full.

You can rotate the power adjust dial according to the ISO value of the camera and shooting distance to get the desired power.

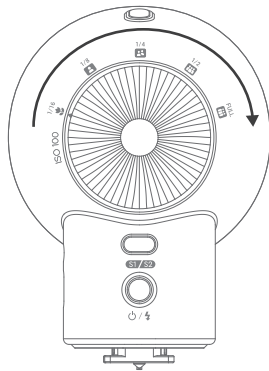

Note: According to the Godox laboratory, the guide number is GN6 in ISO 100 and shooting distance of 1m. Users can adjust the power in accordance with the following practical table and shooting parameters.

Practical Table

Distance(m) GN \ Aperture	2	2.8	4	5.6	8	11	16
24	12	8.5	6	4.2	3	2.1	1.5
17	8.5	6	4.2	3	2.1	1.5	1.1
12	6	4.2	3	2.1	1.5	1.1	0.8
8.4	4.2	3	2.1	1.5	1.1	0.8	0.5
6	3	2.1	1.5	1.1	0.8	0.5	0.4
4.2	2.1	1.5	1.1	0.8	0.5	0.4	0.3
3	1.5	1.1	0.8	0.5	0.4	0.3	0.2
2.1	1.1	0.8	0.5	0.4	0.3	0.2	0.1
1.5	0.8	0.5	0.4	0.3	0.2	0.1	0.08
1.05	0.5	0.4	0.3	0.2	0.1	0.08	0.07

GN \ ISO Flash Power	50	100	200	400	800	1600
1 (full)	4.2	6	8.4	12	17	24
1/2	3	4.2	6	8.4	12	17
1/4	2.1	3	4.2	6	8.4	12
1/8	1.5	2.1	3	4.2	6	8.4
1/16	1.1	1.5	2.1	3	4.2	6

Optical Control Mode



S1 Optical Control

Press the S1/S2 button to make the button turn red, the flash can function as an optical S1 secondary flash. With this function, the flash will fire synchronously when the main flash fires, the same effect as that by using of radio triggers. This helps create multiple lighting effects.

S2 Optical Control

Press the S1/S2 button to make the button turn blue, the flash can also function as an optical S2 secondary flash to be suitable for TTL flash. This is useful when cameras have pre-flash function. With this function, the flash will ignore a single “pre-flash” from the main flash and will only fire in response to the second, actual flash from the main unit.

Technical Data

Data	Lux Elf
GN (1 / 1 step)	GN6 (ISO100, in meters)
Built-in Lithium Battery	7.4V  350mAh
USB-C Port Input	5V  2A
Flash Power Steps	5:1 / 16—FULL
CCT	6000K ± 200K
Optical Control	S1 Optical Control S2 Optical Control
Working Environment Temperature	-10°C ~50°C
Recycle Time (1 / 1 step)	≈ 3.6s
Flash Times (1 / 1 step)	≈ 400
Battery Charging Temperature Range	0°C-45°C
SYNC	Hot Shoe, Sync Cord
Dimension	2.76"× 3.82"× 2.09"
Net Weight≈	96g

Specifications and data may subject to changes without notice.

Declaration of Conformity:

GODOX Photo Equipment Co.,Ltd. hereby declares that the This equipment are in compliance with the essential requirements and other relevant provisions of EU Directive 2014/35/EU, 2014/30/EU. They are allowed to be used in all EU member states.

For more information of DoC, Please click this web link:
<https://www.godox.com/eu-declaration-of-conformity/>

FCC Statement

This device complies with part 15 of the FCC Rules. Operation is subject to the following two conditions:

- (1) This device may not cause harmful interference, and
- (2) this device must accept any interference received, including interference that may cause undesired operation.

Any Changes or modifications not expressly approved by the party responsible for compliance could void the user's authority to operate the equipment.

Note:

This equipment has been tested and found to comply with the limits for a Class B digital device, pursuant to part 15 of the FCC Rules. These limits are designed to provide reasonable protection against harmful interference in a residential installation. This equipment generates uses and can radiate radio frequency energy and, if not installed and used in accordance with the instructions, may cause harmful interference to radio communications. However, there is no guarantee that interference will not occur in

a particular installation. If this equipment does cause harmful interference to radio or television reception, which can be determined by turning the equipment off and on, the user is encouraged to try to correct the interference by one or more of the following measures:

- Reorient or relocate the receiving antenna.
- Increase the separation between the equipment and receiver.
- Connect the equipment into an outlet on a circuit different from that to which the receiver is connected.
- Consult the dealer or an experienced radio/TV technician for help.

产品保修

尊敬的用户，本保修卡是申请保修服务的重要凭证，请您配合销售商填写并妥善保管，谢谢！

产品信息	型号	产品条码
用户信息	姓名	联系电话
	通信地址	
销售商信息	名称	
	联系电话	
	通信地址	
	销售日期	
备注		

注：此表应由销售商盖章确认。

适用产品

本文件适用于相关《产品保修信息》(见后面说明)所列产品，其他非属此范围的产品或部件(如促销品、赠品及其他出厂后附加的部件等)不在此保修承诺内。

保修期

产品及部件的相应保修期按相关的《产品保修信息》执行。保修期自产品首次购买日起算，购买日以购买产品时保修卡登记日期为准。

如何获得保修服务

您可直接与产品销售商或授权服务机构联系，也可拨打神牛产品售后服务电话，与我们联系，由我们的服务人员为您安排服务。申请保修时，您应提供有效的保修卡作为保修凭证，方可获得保修。如您不能提供有效的保修卡，则在我们确认产品或部件属于保修范围的情况下，也可以为您提供保修，但这不作为我们的义务。

不适用保修的情况

如产品存在下列情况，本文件项下的保证和服务将不适用：**①产品或部件超过相应保修期；②错误或不当使用、维护或保管导致的故障或损坏，如：不当搬运；非按产品合理预期用途使用；不当插拔外接设备；跌落或外力挤压；接触或暴露于不当温度、溶剂、酸碱、水浸或潮湿环境；③由非神牛授权机构或人员安装、修理、更改、添加或拆卸造成的故障或损坏；④产品或部件原有识别信息被修改变更或删除；⑤无有效保修卡；⑥使用非合法授权、非标准或非公开发行的软件造成的故障或损坏；⑦因不**

可抗力或意外事件造成的故障或损坏；⑥其他非因产品本身质量问题导致的故障或损坏。遇上述情况，您应向相关责任方寻求解决，神牛对此不承担任何责任。因非在保修期或保修范围内的部件、附件或软件导致产品不能正常使用的，不是保修范围内的故障。产品使用过程中正常的脱色，磨损和消耗，不是保修范围内的故障。

产品保修和服务支持信息

产品的保修期和服务类型按以下《产品保修信息》执行：

产品类别	选件名称	保修期 (月)	保修服务类型
部件	电路板	12	客户送修
	电池	3	客户送修
	充电器等带电性能的部件。	12	客户送修
其他	如闪光管、造型灯泡、外壳、保护罩、锁紧装置、包装等。	无	无保修

Warranty

Dear customers, as this warranty card is an important certificate to apply for our maintenance service, please fill in the following form in coordination with the seller and safe-keep it. Thank you!

Product Information	Model	Product Code Number
Customer Information	Name	Contact Number
	Address	
Seller Information	Name	
	Contact Number	
	Address	
	Date of Sale	
Note:		

Note: This form shall be sealed by the seller.

Applicable Products

The document applies to the products listed on the Product Maintenance Information (see below for further information). Other products or accessories (e.g. promotional items, give-aways and additional accessories attached, etc.) are not included in this warranty scope.

Warranty Period

The warranty period of products and accessories is implemented according to the relevant Product Maintenance Information. The warranty period is calculated from the day (purchase date) when the product is bought for the first time, and the purchase date is considered as the date registered on the warranty card when buying the product.

How to Get the Maintenance Service

If maintenance service is needed, you can directly contact the product distributor or authorized service institutions. You can also contact the Godox after-sale service call and we will offer you service. When applying for maintenance service, you should provide valid warranty card. If you cannot provide valid warranty card, we may offer you maintenance service once

confirmed that the product or accessory is involved in the maintenance scope, but that shall not be considered as our obligation.

Inapplicable Cases

The guarantee and service offered by this document are not applicable in the following cases: ① **The product or accessory has expired its warranty period;** ② **Breakage or damage caused by inappropriate usage, maintenance or preservation, such as improper packing, improper usage, improper plugging in/out external equipment, falling off or squeezing by external force, contacting or exposing to the improper temperature, solvent, acid, base, flooding and damp environments, etc;** ③ **Breakage or damage caused by non-authorized institution or staff in the process of installation, maintenance, alternation, addition and detachment;** ④ **The original identifying information of product or accessory is modified, alternated, or removed;** ⑤ **No valid warranty card;** ⑥ **Breakage or damage caused by using illegally authorized, nonstandard or non-public released software;** ⑦ **Breakage or damage caused by force majeure or accident;** ⑧ **Breakage or damage that could not**

be attributed to the product itself. Once met these situations above, you should **seek solutions from the related responsible parties and Godox assumes no responsibility.** The damage caused by parts, accessories and software that beyond the warranty period or scope is not included in our maintenance scope. The normal discoloration, abrasion and consumption are not the breakage within the maintenance scope.

Maintenance and Service Support Information

The warranty period and service types of products are implemented according to the following Product Maintenance Information:

Product Type	Name	Maintenance Period(month)	Warranty Service Type
Parts	Circuit Board	12	Customer sends the product to designated site
	Battery	3	Customer sends the product to designated site
	Electrical parts e.g.battery charger, etc.	12	Customer sends the product to designated site
Other Items	Flash tube, modeling lamp, lamp body, lamp cover, locking device, package, etc.	NO	Without warranty

Godox After-sale Service Call +86-755-29609320(8062)