

Vaccuperm

Vacuum chlorine gas dosing systems



1. General information	4
Fundamentals of disinfection	4
Principle of a Vaccuperm chlorine gas dosing system	4
Benefits and applications	6
2. Application overviews	7
Vaccuperm - chlorine gas dosing systems up to 4 kg/h	7
3. Compact unit and set	12
Vaccuperm VGB-103 up to 4 kg/h	12
4. Vacuum regulators	20
Vaccuperm VGA-111 up to 4 kg/h	20
5. Dosing regulators	28
Vaccuperm VGA-113 up to 4 kg/h	28
6. Change-over devices	33
189 vacuum change-over device	33
Remote indicator	36
7. Injectors	37
VGB, VGA, and VGS injectors	37
8. Pressure-side accessories	40
Header lines	40
Copper line	44
Corner valve for header line	44
Connection valve for cylinder and drum	45
Connection screwing for connection valve	45
Adapter flange forVGA-146vacuum regulator	46
Adapter flange for copper line	46
Nitrogen rinsing device	47
9. Vacuum-side accessories	48
Chlorine gas adsorption filter	48
Vacuum non-return valve	48
Anti-syphoning valve	49
PE hose	50
Connectors	51
Contact vacuum meter with PE hose connector	52
Ball valve	52

10. General accessories	54
Water unit	54
Non-return valve for high-pressure injector	55
Chlorine cylinder holding clip	55
Chlorine cylinder scale	56
Exhauster fan	56
Chlorine gas neutralisation system (scrubber)	57
Compressed-air respirator	57
Protective PVC suit	57
Gas mask	58
Rubber gloves	58
Rubber apron	58
Protective goggles	58
Body and eye shower	58
Warning signs	59
Conex DIA-G gas warning system	59
Battery backup, horn and flashlight	59
11. Grundfos Product Center	60

1. General information

Fundamentals of disinfection

Drinking water can transmit diseases. Among these diseases are typhus, paratyphoid, cholera and diarrhoea with vomiting, as well as viral infections such as hepatitis and poliomyelitis. Legionella in shower or bathing water can provoke pulmonary diseases. Compared to the chemical contamination of water, where toxicity values are attained only slowly in general, in a drinking water epidemic infections spread dramatically in the whole supply area. The best prevention of epidemics is to use microbiologically clean non-polluted water, preferably deep ground water as drinking water. Unfortunately, in some regions this is not possible for hydrogeological or quantitative reasons. In these regions, surface water is used, which often has to be purified. Pathogens that are possibly encountered, can be removed from the water or killed by adding certain substances to the water, i.e. by disinfecting the water.

Disinfection with chlorine

The most widespread disinfectant used in the treatment of drinking water is chlorine, which can be applied in a variety of ways. History has taught us that, in bacteriological terms, chlorinating water is a quite safe way of disinfecting drinking water. After all, more than 100 years have passed since chlorine was used to disinfect drinking water for the first time. Many years of experience have shown that acute toxicity can be excluded, when chlorination is executed correctly.

Generally, three methods are used for the chlorination of drinking water and also process water:

- Chlorine gas dosing
- Dosing of commercial sodium hypochlorite solution or calcium hypochlorite solution
- Electrolytic sodium hypochlorite generation on site

Chlorine gas dosing offers a number of advantages, which are combined in the Vaccuperm product range.

Principle of a Vaccuperm chlorine gas dosing system

The handling, transport and storage of chlorine for water disinfection has always been a challenge to systems engineering. This is the reason why the vacuum principle has been used in dosing systems for a long time already. With the vacuum principle, the pressure of the chlorine gas is reduced to a vacuum. In the event of a pipe breakage, no chlorine gas can escape, only ambient air is drawn in.

Vacuum chlorine gas dosing systems operate according to the vacuum principle and are composed of three basic components:

- Chlorine container (cylinder or drum) (A)
- Vacuum regulator (B)
- Dosing regulator (C)
- Injector (D)

Chlorine container (A)

Chlorine containers are not completely filled with liquid chlorine. Above the liquid chlorine (A2) there is chlorine gas (A1), which has evaporated from the liquid chlorine. About 1% of the maximum content of a chlorine container can be extracted continuously per hour, otherwise the container will freeze (e.g. 650 g/h can be extracted from a cylinder with 65 kg). If a larger quantity is required, it can be extracted from several containers (cylinders or drums) in parallel. As a rule, liquid chlorine is extracted when more than 40 kg/h is required. According to the ambient temperature, the chlorine storage room must be heated, so that the surface temperature of the chlorine container doesn't fall below 15 °C.

Vacuum regulator (B)

The vacuum regulator is a pressure reducing valve, which reduces pressure from the chlorine tank side to the negative pressure on the vacuum side. The valve opens, when sufficient vacuum is present on the outlet side. The vacuum regulator regulates the vacuum to a constant level over the whole range.

Pressure relief function (F)

In case of a small internal leakage, for example due to a dirty inlet-valve seat, the internal pressure relief function protects the vacuum system from inadmissible pressure on the vacuum side. The chlorine gas flows over the vent outlet to the chlorine adsorption filter.

Prevention of air entering the system (E)

If the chlorine cylinder is empty and there is no pressure in it, the vacuum in the system increases, which causes the diaphragm to close. This prevents air from entering the vacuum regulator during a cylinder change (only while the injector is in operation). If the chlorine cylinder is full, a sufficient inlet pressure opens the vacuum regulator automatically.

Dosing regulator (C)

The chlorine gas volume flow is adjusted by the dosing regulator. This can be done manually or automatically via motor control. A differential pressure regulator reduces and regulates the injector vacuum to a constant level to secure a constant and linear gas flow.

VGA-113-311, VGA-113-391 and VGS dosing regulators operate with a differential pressure regulator, which is included in the same housing.

VGB-103, VGA-113-110, VGA-117-110 and VGA-117-190 dosing regulators operate without a differential pressure regulator. A constant and linear chlorine gas flow is achieved under sonic flow conditions.

Dosing regulators without a differential pressure regulator operate with VGB injectors. VGB injectors have a higher performance but require larger motive water flow and higher motive water pressure. Dosing regulators without a differential pressure regulator do not comply with DIN 19606.

Injector (D)

Injectors have the task to bring chlorine gas into the water flow. They operate according to the principle of a water jet pump.

The injector body comprises a nozzle followed by a diffusor. Between the nozzle and the diffusor, there is a narrow ring-shaped gap, where the chlorine gas is sucked out of the dosing line through the injector head into the water flow. A diaphragm non-return valve at the dosing line prevents the ingress of water into the dosing line after shutting down the water flow.

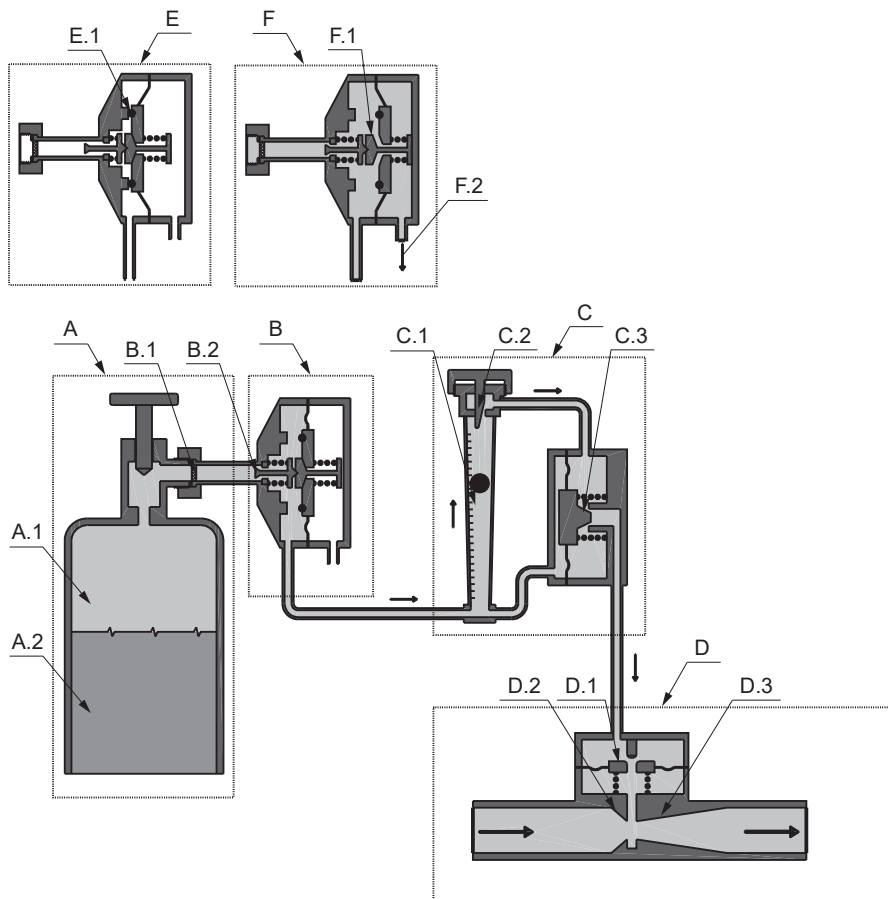

TM074892

Schematic diagram of a chlorine gas dosing system

Pos.	Component	Pos.	Component
A	Chlorine cylinder	D	Injector
A.1	Chlorine gas	D.1	Diaphragm non-return valve
A.2	Chlorine liquid	D.2	Nozzle
B	Vacuum regulator	D.3	Diffusor
B.1	Inlet filter	E	Vacuum regulator with empty chlorine cylinder

Pos.	Component	Pos.	Component
B.2	Inlet valve	E.1	Vacuum seal
C	Dosing regulator	F	Vacuum regulator with open pressure relief valve
C.1	Flowmeter	F.1	Pressure relief valve
C.2	Rate valve	F.2	Vent outlet
C.3	Differential pressure regulator		

Benefits and applications

Benefits

- Safe system using the vacuum principle
- Most economical way of disinfection
- Manufacturer has over 50 years of experience in disinfection with chlorine gas

Applications

- Drinking water treatment
- Waste water treatment
- Industrial water treatment
- Cooling towers
- Swimming pools

2. Application overviews

Vaccuperm - chlorine gas dosing systems up to 4 kg/h

Low-budget chlorine extraction from one cylinder

Vaccuperm chlorine gas dosing systems with VGB-103 compact unit.

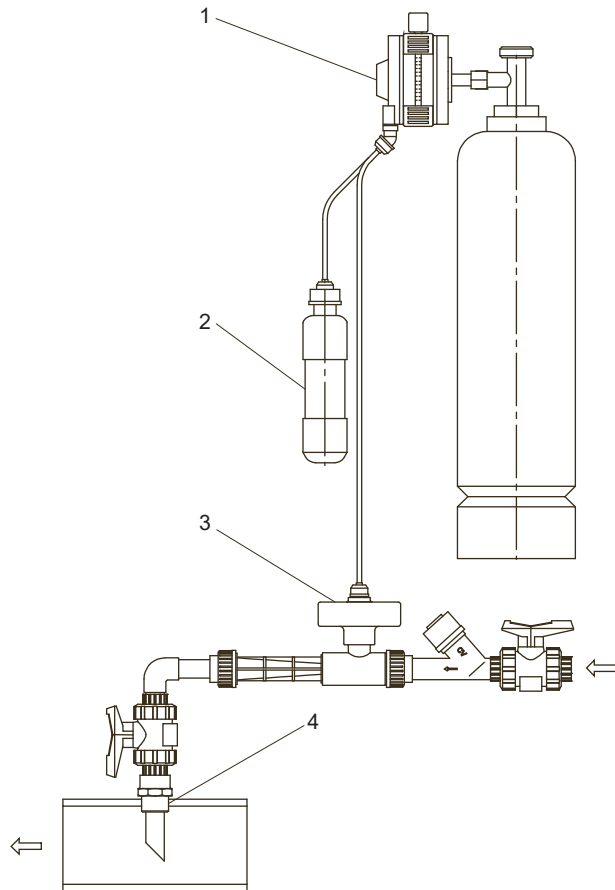

TM075195

Pos.	Component
1	VGB-103 compact unit
2	Chlorine gas adsorption filter
3	VGB injector
4	Injection unit

Low-budget manual chlorine extraction from one or more cylinders

Vaccuperm manual chlorine gas dosing systems with VGA-111 vacuum regulators and a VGA-113-110 dosing regulator.

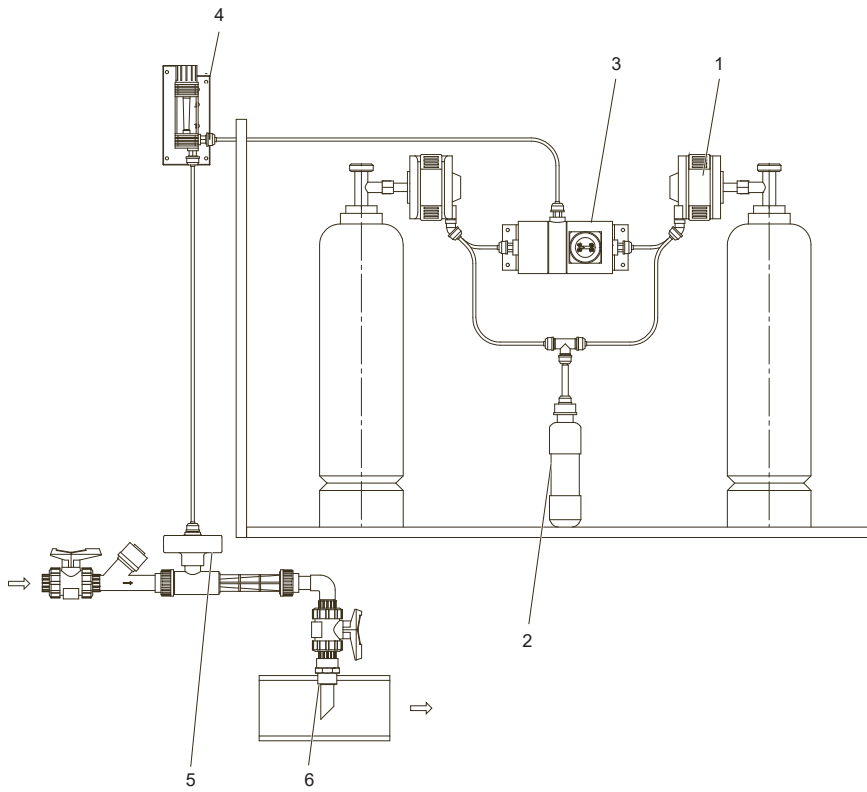

TM075191

Pos.	Component
1	VGA-111 vacuum regulator
2	Chlorine gas adsorption filter
3	189 change-over device
4	VGA-113-110 dosing regulator
5	VGB injector
6	Injection unit

Manual or automatic chlorine extraction from one or more cylinders

Vaccuperm manual or automatic chlorine gas dosing systems with VGA-111 vacuum regulators and a VGA-113-311 manual dosing regulator or a VGA-113-391 automatic dosing regulator.

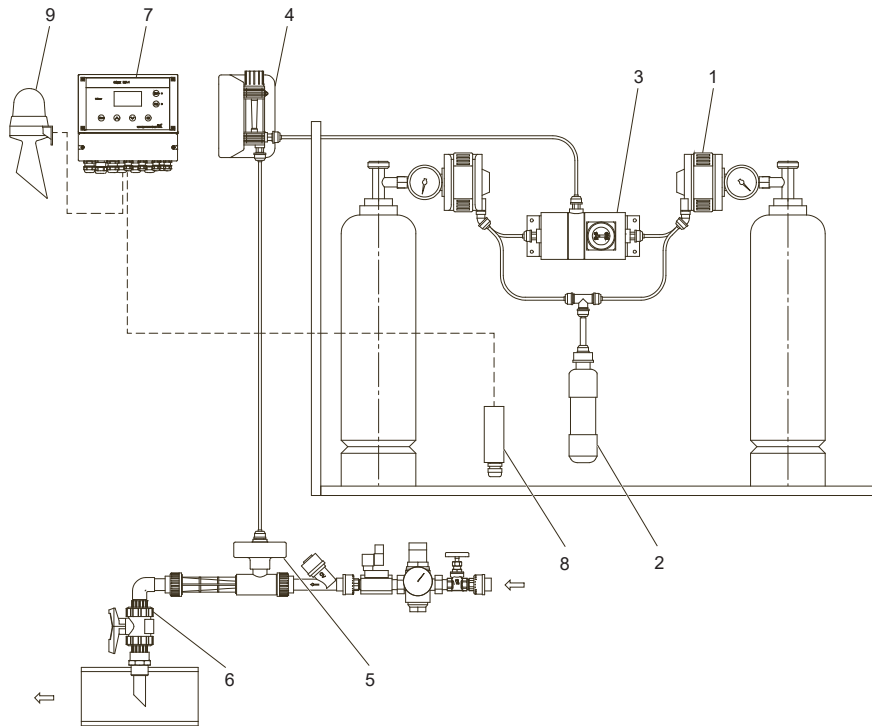

TM075192

Pos.	Component
1	VGA-111 vacuum regulator
2	Chlorine gas adsorption filter
3	189 change-over device
4	VGA-113-311 manual dosing regulator or VGA-113-391 automatic dosing regulator
5	VGA injector
6	Injection unit
7	Conex DIA-G gas warning system
8	Gas sensor
9	Horn and flashlight

Manual or automatic chlorine extraction from two banks of cylinders

Vaccuperm manual or automatic chlorine gas dosing systems with VGA-111 vacuum regulators and a VGA-113-311 manual dosing regulator or a VGA-113-391 automatic dosing regulator.

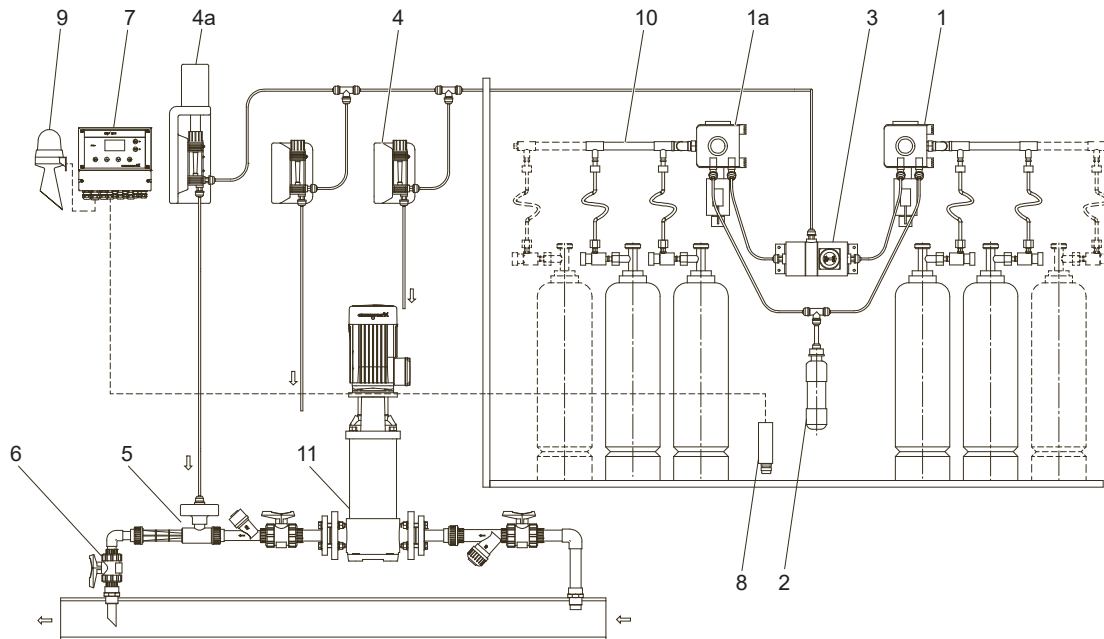

TM075190

Pos.	Component
1	VGA-111 vacuum regulator with heated liquid trap (pressure inlet right)
1a	VGA-111 vacuum regulator with heated liquid trap (pressure inlet left)
2	Chlorine gas adsorption filter
3	189 change-over device
4	VGA-113-311 manual dosing regulator
4a	VGA-113-391 automatic dosing regulator
5	VGA injector
6	Injection unit
7	Conex DIA-G gas warning system
8	Gas sensor
9	Horn and flashlight
10	Header line for chlorine cylinders
11	CR booster pump

Manual or automatic chlorine extraction from several cylinders according to DIN 19606 (full-vacuum system)

Vaccuperm chlorine gas dosing systems with VGA-111 vacuum regulators and a VGA-113-311 manual dosing regulator or a VGA-113-391 automatic dosing regulator.

Chlorine gas dosing according to DIN 19606 eliminates the risk of a chlorine leakage at the header line. This application type is also called "full vacuum system". Instead of using a pressurised header line, the vacuum regulators are connected directly to the chlorine cylinders. The vacuum regulators are directly connected to a vacuum header line. To prevent freezing of the cylinders, a vacuum regulator with flow limiting nozzle must be selected, which limits the extraction capacity to 650 g/h. In most cases, a change-over device is not used, as cylinder exchange is performed while the system is in operation.

A safety valve is needed if the injector is located outside the chlorination room. This protects the vacuum line to the injector in case of overpressure.

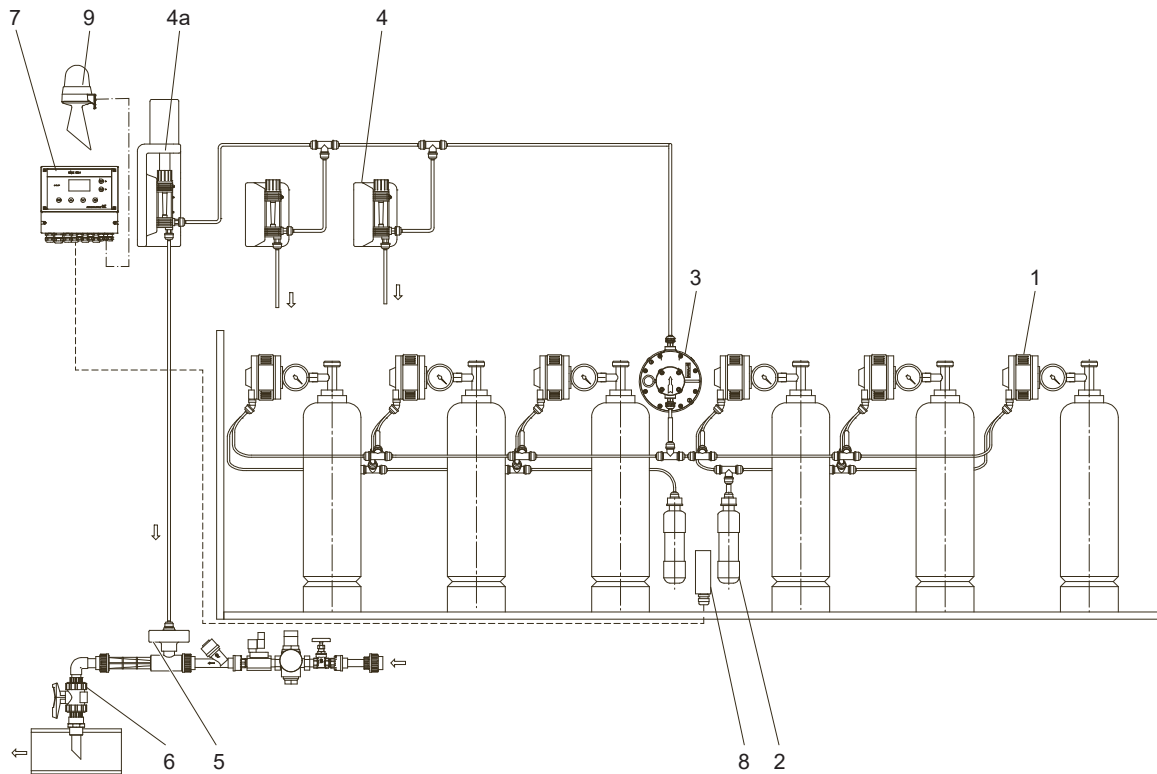

TM075189

Pos.	Component
1	VGA-111 vacuum regulator with flow-limiting nozzle
2	Chlorine gas adsorption filter
3	543 safety valve
4	VGA-113-311 manual dosing regulator
4a	VGA-113-391 automatic dosing regulator
5	VGA injector
6	Injection unit
7	Conex DIA-G gas warning system
8	Gas sensor
9	Horn and flashlight

3. Compact unit and set

Vaccuperm VGB-103 up to 4 kg/h

Vaccuperm VGB-103 compact unit

The convenient VGB-103 compact unit combines a vacuum regulator and a dosing regulator in one housing for direct mounting on a chlorine gas cylinder or header line. The VGB-103 operates under sonic flow conditions without a differential pressure regulator. A VGB injector is required.

The VGB-103 compact unit is available with the following features:

- Manual chlorine capacity adjustment
- Integrated flowmeter (float principle)
- Various capacities
- Vacuum connections for 8/11 PE hose
- Visual indication of an empty chlorine cylinder
- Integrated pressure-relief valve
- Chlorine-resistant metal inlet valve with PTFE filter for easy maintenance
- 5 gaskets for pressure-side connections

The VGB-103 compact unit is not usable with change-over device or servomotor.

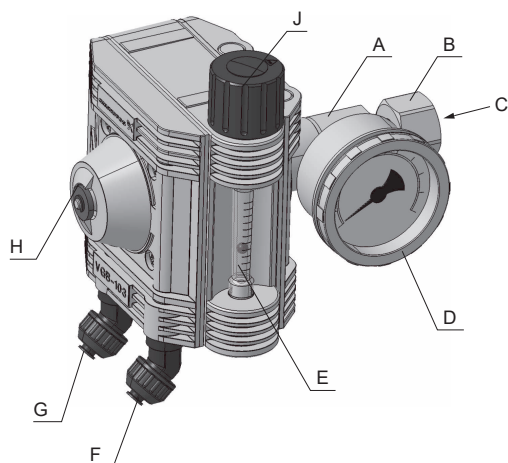

TM075042



TM075174

Pos.	Component
A	Inlet valve
B	Inlet, pressure connection
C	Filter
D	Pressure gauge
E	Flowmeter
F	Outlet, vacuum connection (to injector)
G	Outlet, vent connection
H	Visual indication of empty chlorine cylinder
J	Manual chlorine capacity adjustment

VGB-103 set

The VGB-103 set is a combination of the following components ready to use:

- VGB-103 compact unit
- Pre-selected VGB injector
- Vacuum hose 8/11, 10 m

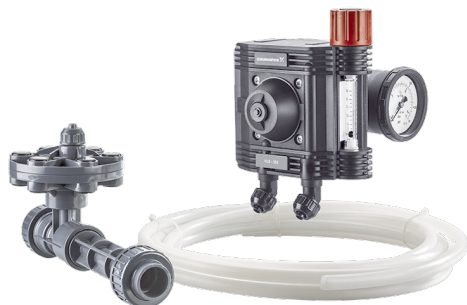

TM075175

Technical data VGB-103

VGB-103 compact unit	
Medium	Chlorine gas
Capacity ranges	5-100 g/h, 10-250 g/h, 25-500 g/h, 50-1000 g/h, 100-2000 g/h, 150-3000 g/h, 200-4000 g/h
Adjustment ratio	1:20
Accuracy	± 4 %
Measuring device	According to the floater principle, measuring tube 70 mm
Empty indication	Visual indication of lack of chlorine
Material	<ul style="list-style-type: none"> • Enclosure: PVC • Inlet valve: silver/PTFE, special alloy • Springs: alloy C-4, coated • Diaphragm: FEP • Filter: PTFE • Rate valve: PVC • O-rings: FKM
Connections	Pressure connection inlet: <ul style="list-style-type: none"> • Union nut 1", G 3/4 • Yoke USA Vacuum connection outlet: <ul style="list-style-type: none"> • PE hose 8/11 Vent connection outlet: <ul style="list-style-type: none"> • PE hose 8/11
Pressure gauge	Pressure range: 0 to 16 bar
Weight	1.3 to 2 kg
Injector	
Material	<ul style="list-style-type: none"> • Housing: PVC • Spring: alloy C-4, PTFE coated • Diaphragm: FEP
Ambient temperature	+5 °C to +40 °C
Motive water temperature	+5 °C to +30 °C
Motive water pressure	see table below
Counterpressure	see table below

VGB-103 set, injector

Capacity [kg/h]	Motive water pressure [bar]	Counterpressure [bar]	Water quantity [l/h]	Water connection	Vacuum hose connection
0.5	2-16	0-7	550-1350	DN 20	PE 8/11
1.0	2-16	0-7	850-2200	DN 20	
2.0	2-16	0-7	1200-3300	DN 20	
3.0	4-15	0-7	2500-4300	DN 25	
4.0	4-8	0-3	3400-4700	DN 25	

Dimensions VGB-103

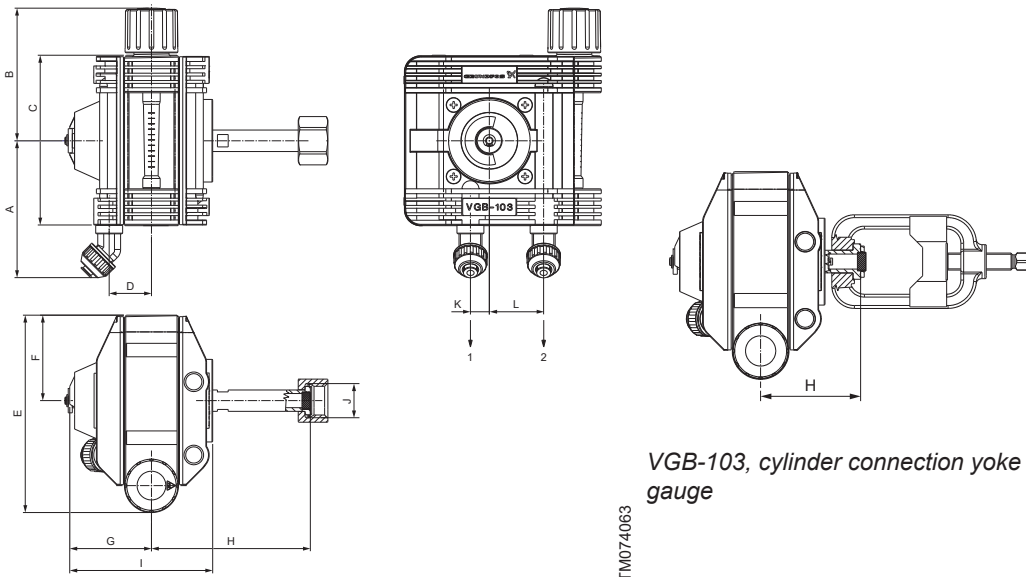

VGB-103, cylinder connection 1", G 3/4, without pressure gauge

VGB-103, cylinder connection yoke USA, without pressure gauge

TM074085

TM074063

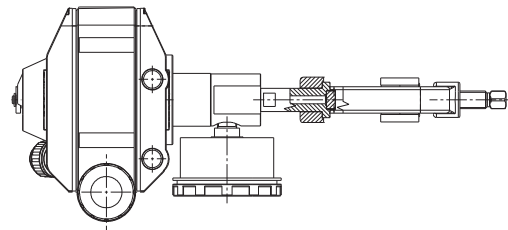
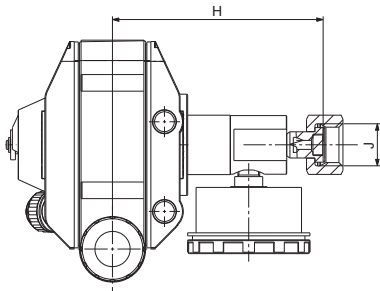
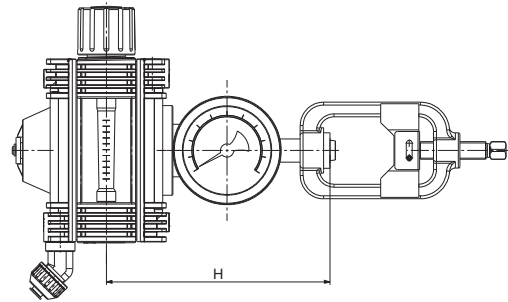
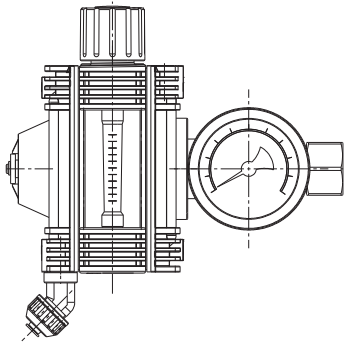

TM075043

TM075044

VGB-103, cylinder connection 1", G 3/4 with pressure gauge

VGB-103, cylinder connection yoke USA, with pressure gauge

Dimensions in mm

J	A	B	C	D	E	F	G	I	K	L
1"										
G 3/4	102	98	126	31.4	146	63	60.6	106	14	40
Yoke USA										

J	Without pressure gauge		With pressure gauge	
	H		H	
1"	118		127	
G 3/4	71		153	
Yoke USA	71		153	

Dimensions of injector

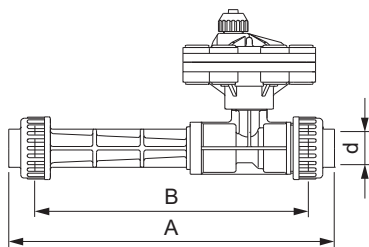

TM041250

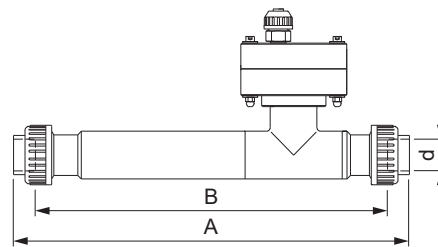

TM041256

Injector DN 20

Injector DN 25

Dimensions in mm

d	A	B
DN 20	275	232
DN 25	400	350

Type key VGB-103

Type	
VGB-103 -250/1/11-S-1-O,B0/NRW8,10G,C3	
VGB-103	Vaccuperm compact unit/set
Capacity	
VGB-103-250/1/11-S-1-O,B0/NRW8,10G,C3	
100	5-100 g/h
250	10-250 g/h
500	25-500 g/h
1000	50-1000 g/h
2000	100-2000 g/h
3000	150-3000 g/h
4000	400-4000 g/h
Pressure connection, inlet	
VGB-103-250/1/11-S-1-O,B0/NRW8,10G,C3	
1	1"
2	G 3/4
3	Yoke USA
Vacuum connection, outlet	
VGB-103-250/1/11-S-1-O,B0/NRW8,10G,C3	
11	PE hose 8/11
Inlet valve	
VGB-103-250/1/11-S-1-O,B0/NRW8,10G,C3	
B	Basic, not for pressure gauge
S	Short, for pressure gauge
Pressure gauge	
VGB-103-250/1/11-S-1-O,B0/NRW8,10G,C3	
0	Without
1	Pressure gauge without contact
Filter	
VGB-103-250/1/11-S-1-O,B0/NRW8,10G,C3	
0	Filter in pressure connection
Installation type	
VGB-103-250/1/11-S-1-O,B0/NRW8,10G,C3	
B	Cylinder mounting, pressure connection frontal
Residual pressure device	
VGB-103-250/1/11-S-1-O,B0/NRW8,10G,C3	
0	Without
Injector	
VGB-103-250/1/11-S-1-O,B0/NRW8,10G,C3	
N	Without
NR	Injector with diaphragm non-return valve
Water connection for injector	
VGB-103-250/1/11-S-1-O,B0/NRW8,10G,C3	
N	Without
W8	DN 20 (20/25) (4/10 kg/h)
W9	DN 25 (25/32) (10 kg/h)

Accessories	
VGB-103-250/1/11-S-1-O,B0/NRW8, <u>10</u> G,C3	
0	Without
<u>10</u>	PE vacuum hose, 8/11, 10 m
Logo	
VGB-103-250/1/11-S-1-O,B0/NRW8,10 <u>G</u> ,C3	
<u>G</u>	Grundfos
Product certificate	
VGB-103-250/1/11-S-1-O,B0/NRW8,10G, <u>C3</u>	
<u>C3</u>	Certificate 3.1 (EN 10204)

Order data for VGB-103

VGB-103 compact unit without pressure gauge

Capacity [g/h]	Cylinder connection	Type designation	Product number	Product number with certificate 3.1
5-100	1"	VGB-103-100/1/11-B-0-O,B0/NN,0-G	95712114	95759542
	G 3/4	VGB-103-100/2/11-B-0-O,B0/NN,0-G	95712119	95759543
	Yoke USA	VGB-103-100/3/11-B-0-O,B0/NN,0-G	95712123	95759544
10-250	1"	VGB-103-250/1/11-B-0-O,B0/NN,0-G	95712126	95759545
	G 3/4	VGB-103-250/2/11-B-0-O,B0/NN,0-G	95712131	95759546
	Yoke USA	VGB-103-250/3/11-B-0-O,B0/NN,0-G	95712136	95759547
25-500	1"	VGB-103-500/1/11-B-0-O,B0/NN,0-G	95712139	95759548
	G 3/4	VGB-103-500/2/11-B-0-O,B0/NN,0-G	95712153	95759549
	Yoke USA	VGB-103-500/3/11-B-0-O,B0/NN,0-G	95712159	95759550
50-1000	1"	VGB-103-1000/1/11-B-0-O,B0/NN,0-G	95712162	95759551
	G 3/4	VGB-103-1000/2/11-B-0-O,B0/NN,0-G	95712167	95759552
	Yoke USA	VGB-103-1000/3/11-B-0-O,B0/NN,0-G	95712170	95759553
100-2000	1"	VGB-103-2000/1/11-B-0-O,B0/NN,0-G	95712173	95759554
	G 3/4	VGB-103-2000/2/11-B-0-O,B0/NN,0-G	95712178	95759555
	Yoke USA	VGB-103-2000/3/11-B-0-O,B0/NN,0-G	95712181	95759556
150-3000	1"	VGB-103-3000/1/11-B-0-O,B0/NN,0-G	95759557	95759558
	G 3/4	VGB-103-3000/2/11-B-0-O,B0/NN,0-G	95745942	95759559
	Yoke USA	VGB-103-3000/3/11-B-0-O,B0/NN,0-G	95748087	95759560
200-4000	1"	VGB-103-4000/1/11-B-0-O,B0/NN,0-G	95759561	95759562
	G 3/4	VGB-103-4000/2/11-B-0-O,B0/NN,0-G	95745943	95759563
	Yoke USA	VGB-103-4000/3/11-B-0-O,B0/NN,0-G	95759564	95759565

VGB-103 compact unit with pressure gauge

Capacity [g/h]	Cylinder connection	Type designation	Product number	Product number with certificate 3.1
5-100	1"	VGB-103-100/1/11-S-1-O,B0/NN,0-G	95712117	95759568
	G 3/4	VGB-103-100/2/11-S-1-O,B0/NN,0-G	95759569	95759570
	Yoke USA	VGB-103-100/3/11-S-1-O,B0/NN,0-G	95759571	95759572
10-250	1"	VGB-103-250/1/11-S-1-O,B0/NN,0-G	95712129	95759573
	G 3/4	VGB-103-250/2/11-S-1-O,B0/NN,0-G	95759574	95759575
	Yoke USA	VGB-103-250/3/11-S-1-O,B0/NN,0-G	95759576	95759577
25-500	1"	VGB-103-500/1/11-S-1-O,B0/NN,0-G	95712151	95759578
	G 3/4	VGB-103-500/2/11-S-1-O,B0/NN,0-G	95759579	95759580
	Yoke USA	VGB-103-500/3/11-S-1-O,B0/NN,0-G	95759581	95759582
50-1000	1"	VGB-103-1000/1/11-S-1-O,B0/NN,0-G	95712165	95759583
	G 3/4	VGB-103-1000/2/11-S-1-O,B0/NN,0-G	95759584	95759585
	Yoke USA	VGB-103-1000/3/11-S-1-O,B0/NN,0-G	95759586	95759587
100-2000	1"	VGB-103-2000/1/11-S-1-O,B0/NN,0-G	95712176	95759588
	G 3/4	VGB-103-2000/2/11-S-1-O,B0/NN,0-G	95759589	95759590
	Yoke USA	VGB-103-2000/3/11-S-1-O,B0/NN,0-G	95759591	95759592
150-3000	1"	VGB-103-3000/1/11-S-1-O,B0/NN,0-G	95759593	95759594
	G 3/4	VGB-103-3000/2/11-S-1-O,B0/NN,0-G	95759595	95759596
	Yoke USA	VGB-103-3000/3/11-S-1-O,B0/NN,0-G	95759597	95759598
200-4000	1"	VGB-103-4000/1/11-S-1-O,B0/NN,0-G	95759599	95759600
	G 3/4	VGB-103-4000/2/11-S-1-O,B0/NN,0-G	95759601	95759602
	Yoke USA	VGB-103-4000/3/11-S-1-O,B0/NN,0-G	95759603	95759604

VGB-103 set without pressure gauge

Capacity [g/h]	Cylinder connection	Type designation	Product number	Product number with certificate 3.1
5-100	1"	VGB-103-100/1/11-B-0-O,B0/NRW8,10-G	95759446	95759447
	G 3/4	VGB-103-100/2/11-B-0-O,B0/NRW8,10-G	95759448	95759449
	Yoke USA	VGB-103-100/3/11-B-0-O,B0/NRW8,10-G	95759450	95759451
10-250	1"	VGB-103-250/1/11-B-0-O,B0/NRW8,10-G	95759452	95759453
	G 3/4	VGB-103-250/2/11-B-0-O,B0/NRW8,10-G	95759454	95759455
	Yoke USA	VGB-103-250/3/11-B-0-O,B0/NRW8,10-G	95759456	95759457
25-500	1"	VGB-103-500/1/11-B-0-O,B0/NRW8,10-G	95759458	95759459
	G 3/4	VGB-103-500/2/11-B-0-O,B0/NRW8,10-G	95759460	95759461
	Yoke USA	VGB-103-500/3/11-B-0-O,B0/NRW8,10-G	95759462	95759463
50-1000	1"	VGB-103-1000/1/11-B-0-O,B0/NRW8,10-G	95759464	95759465
	G 3/4	VGB-103-1000/2/11-B-0-O,B0/NRW8,10-G	95759466	95759467
	Yoke USA	VGB-103-1000/3/11-B-0-O,B0/NRW8,10-G	95759468	95759469
100-2000	1"	VGB-103-2000/1/11-B-0-O,B0/NRW8,10-G	95759470	95759471
	G 3/4	VGB-103-2000/2/11-B-0-O,B0/NRW8,10-G	95759472	95759473
	Yoke	VGB-103-2000/3/11-B-0-O,B0/NRW8,10-G	95759474	95759475
150-3000	1"	VGB-103-3000/1/11-B-0-O,B0/NRW9,10-G	95759476	95759477
	G 3/4	VGB-103-3000/2/11-B-0-O,B0/NRW9,10-G	95759478	95759479
	Yoke USA	VGB-103-3000/3/11-B-0-O,B0/NRW9,10-G	95759480	95759481
200-4000	1"	VGB-103-4000/1/11-B-0-O,B0/NRW9,10-G	95759482	95759483
	G 3/4	VGB-103-4000/2/11-B-0-O,B0/NRW9,10-G	95759484	95759485
	Yoke USA	VGB-103-4000/3/11-B-0-O,B0/NRW9,10-G	95759486	95759487

VGB-103 set with pressure gauge

Capacity [g/h]	Cylinder connection	Type designation	Product number	Product number with certificate 3.1
5-100	1"	VGB-103-100/1/11-S-1-O,B0/NRW8,10-G	96680051	95759488
	G 3/4	VGB-103-100/2/11-S-1-O,B0/NRW8,10-G	95759498	95759499
	Yoke USA	VGB-103-100/3/11-S-1-O,B0/NRW8,10-G	95759500	95759501
10-250	1"	VGB-103-250/1/11-S-1-O,B0/NRW8,10-G	95759502	95759503
	G 3/4	VGB-103-250/2/11-S-1-O,B0/NRW8,10-G	95759504	95759505
	Yoke USA	VGB-103-250/3/11-S-1-O,B0/NRW8,10-G	95759507	95759508
25-500	1"	VGB-103-500/1/11-S-1-O,B0/NRW8,10-G	95759509	95759510
	G 3/4	VGB-103-500/2/11-S-1-O,B0/NRW8,10-G	95759513	95759514
	Yoke USA	VGB-103-500/3/11-S-1-O,B0/NRW8,10-G	95759515	95759516
50-1000	1"	VGB-103-1000/1/11-S-1-O,B0/NRW8,10-G	95759517	95759518
	G 3/4	VGB-103-1000/2/11-S-1-O,B0/NRW8,10-G	95759519	95759520
	Yoke USA	VGB-103-1000/3/11-S-1-O,B0/NRW8,10-G	95759521	95759522
100-2000	1"	VGB-103-2000/1/11-S-1-O,B0/NRW8,10-G	95759523	95759524
	G 3/4	VGB-103-2000/2/11-S-1-O,B0/NRW8,10-G	95759525	95759526
	Yoke USA	VGB-103-2000/3/11-S-1-O,B0/NRW8,10-G	95759527	95759528
150-3000	1"	VGB-103-3000/1/11-S-1-O,B0/NRW9,10-G	95759529	95759531
	G 3/4	VGB-103-3000/2/11-S-1-O,B0/NRW9,10-G	95759532	95759533
	Yoke USA	VGB-103-3000/3/11-S-1-O,B0/NRW9,10-G	95759534	95759535
200-4000	1"	VGB-103-4000/1/11-S-1-O,B0/NRW9,10-G	95759536	95759537
	G 3/4	VGB-103-4000/2/11-S-1-O,B0/NRW9,10-G	95759538	95759539
	Yoke USA	VGB-103-4000/3/11-S-1-O,B0/NRW9,10-G	95759540	95759541

4. Vacuum regulators

Vaccuperm VGA-111 up to 4 kg/h

The VGA-111 vacuum regulator for chlorine capacities up to 4 kg/h is intended for operation with a 189 change-over device and a VGA-113 or VGA-117 single or multiple dosing regulator.

The VGA-111 vacuum regulator is available with different thread sizes and yoke connection for various installation options:

- Cylinder mounting
- Drum mounting
- Header-line mounting
- Wall mounting

The VGA-111 vacuum regulator includes:

- Internal filter, easily accessible for maintenance
- Integrated pressure-relief valve
- Visual indication of empty chlorine cylinder
- 5 gaskets for pressure-side connections

Options:

- Flow-limiting nozzle for chlorine withdrawal not exceeding 650 g/h (DIN 19606)
- Residual pressure device to ensure that a chlorine cylinder is not completely emptied to prevent moisture from entering
- Chlorine-resistant pressure-gauge with or without contact for monitoring the pressure in the chlorine cylinder or drum
- Heated liquid trap to prevent liquid chlorine from entering the inlet valve (recommended for applications with chlorine drums and header lines)

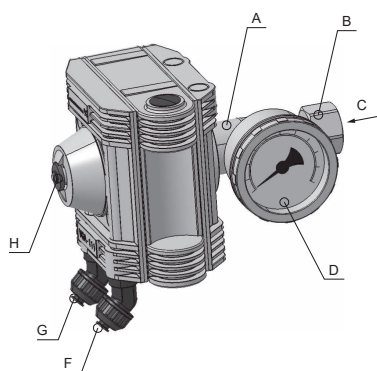

VGA-111, cylinder mounting

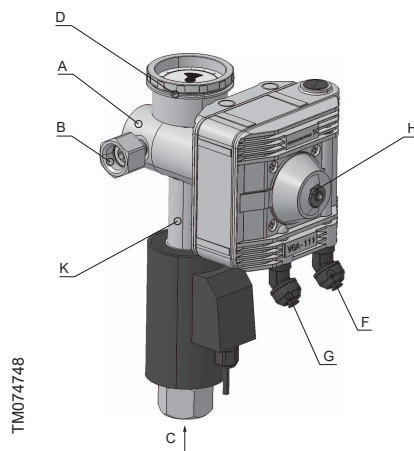

VGA-111, header-line mounting, with heated liquid trap

Pos.	Component	Pos.	Component
A	Inlet valve	F	Outlet, vacuum connection
B	Inlet, pressure connection	G	Outlet, vent connection
C	Filter	H	Visual indication of empty chlorine cylinder
D	Pressure gauge	K	Heated liquid trap

Technical data VGA-111

Medium	Chlorine gas
Capacity	Up to 4000 g/h
Empty indication	Visual indication of lack of chlorine
Material	<ul style="list-style-type: none"> • Enclosure: PVC • Inlet valve: silver, PTFE, special alloy • Springs: alloy C-4, coated • Diaphragm: FEP • Filter: PTFE/ceramic • O-rings: FKM
Connections	<p>Pressure connection inlet:</p> <ul style="list-style-type: none"> • Union nut 1"; G 3/4; G 5/8; 1 1/4"; G 1/2 • Yoke USA <p>Vacuum connection outlet:</p> <ul style="list-style-type: none"> • PE hose 8/11 <p>Vent connection outlet:</p> <ul style="list-style-type: none"> • PE hose 8/11
Pressure gauge	<ul style="list-style-type: none"> • Pressure range: 0 to 16 bar • Without contact or with contact • Contact (R4) closes at falling pressure • Contact (R5) opens at falling pressure • Max. 10 W, 75 VDC, 50 VAC, 0.5 A
Heater for liquid trap	Max. 12 W, 230 or 115 V, 50/60 Hz, IP54
Weight	2.4 kg; 4.4 kg (with heated liquid trap)

Dimensions VGA-111

- VGA-111 with pressure gauge, for cylinder or header-line mounting

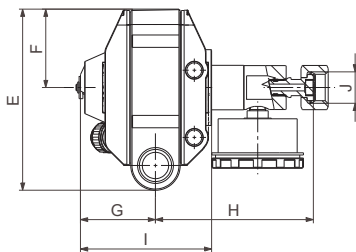
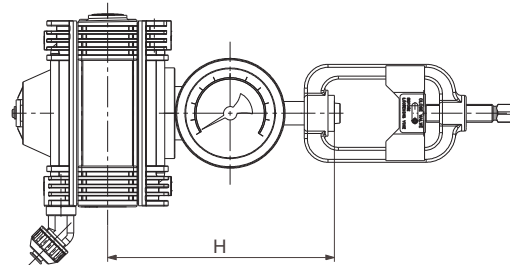
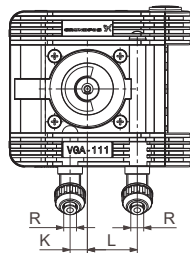
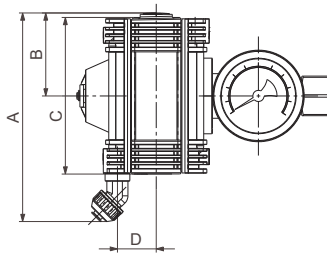

TM074743

TM074746

VGA-111, pressure connection yoke USA

VGA-111, pressure connection 1", G 5/8, G 3/4

- VGA-111 without pressure gauge, for cylinder or header-line mounting

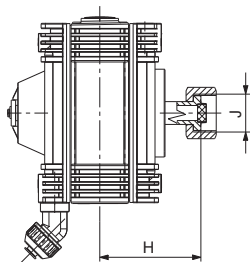

TM074986

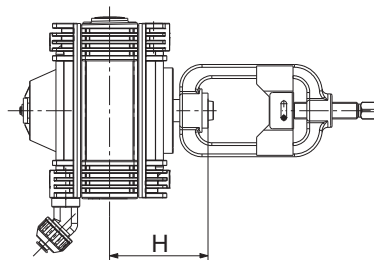

TM074987

VGA-111, pressure connection 1", G 3/4

VGA-111, cylinder connection yoke USA

- VGA-111 with pressure gauge and heated liquid trap, for header-line mounting

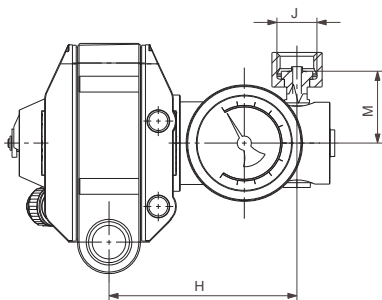

TM074749

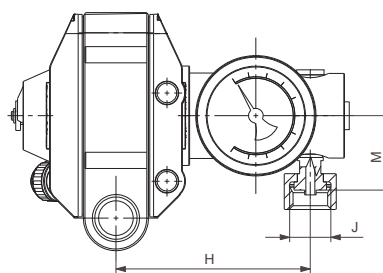

TM074754

VGA-111, pressure connection 1", G 3/4, pressure inlet left

VGA-111, pressure connection 1", G 3/4, pressure inlet right

- VGA-111 with pressure gauge and heated liquid trap, for drum mounting

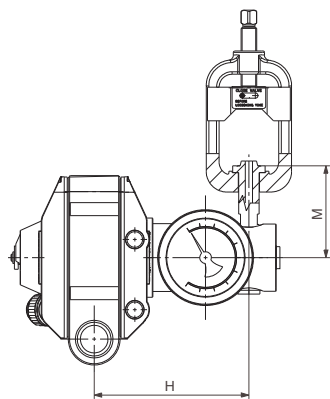

TM074751

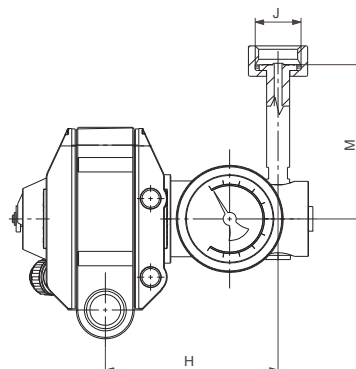

TM074752

VGA-111, pressure connection yoke USA, pressure inlet left

VGA-111, pressure connection 1 1/4", pressure inlet left

- VGA-111 for wall mounting

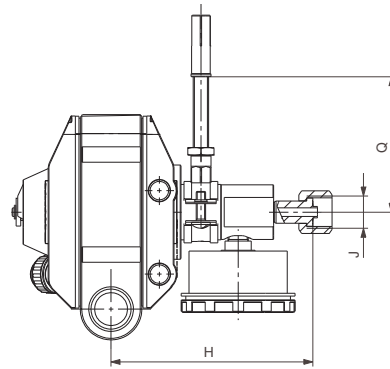
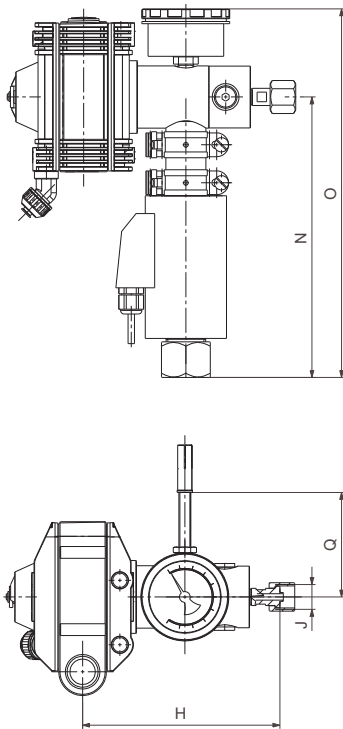

VGA-111, pressure connection G 1/2, without heated liquid trap

TM074753

TM074747

VGA-111, pressure connection G 1/2, with heated liquid trap

Dimensions in mm

J	A	B	C	D	E	F	G	I	K	L	Q	R
1"												
G 5/8												
G 3/4												
Yoke USA	170	67	126	31	146	63	61	106	14	40	-	8/11
1 1/4"												
G 1/2												88

J	With pressure gauge		Without pressure gauge		With heated liquid trap and pressure gauge		
	H	H	H	M	N	O	
1"	127	118	120	46	236	310	
G 5/8	127	-	-	-	-	-	
G 3/4	153	71	120	71	236	310	
Yoke USA	153	71	120	71	236	310	
1 1/4"	-	-	120	107	236	310	
G 1/2	131	-	166	-	236	310	

Type key VGA-111

Type	
VGA-111 -4/BC/1/11-S-1R-0-O,0F-G,C3	
VGA-111	Vacuum regulator
Capacity	
VGA-111-4/BC/1/11-S-1R-0-O,0F-G,C3	
4	4 kg/h
Installation type	
VGA-111-4/BC/1/11-S-1R-0-O,0F-G,C3	
B	Cylinder mounting, without heated liquid trap
BC	Cylinder or header line mounting, without heated liquid trap
D	Drum mounting, with heated liquid trap
W	Wall mounting, with or without heated liquid trap
C	Header-line mounting, with heated liquid trap
Pressure connection, inlet	
VGA-111-4/BC/1/11-S-1R-0-O,0F-G,C3	
1	1"
2	G 3/4
3	Yoke USA
4	G ½ copper line
9	G 5/8
14	1 ¼"
Vacuum connection, outlet	
VGA-111-4/BC/1/11-S-1R-0-O,0F-G,C3	
11	PE hose 8/11
Inlet valve	
VGA-111-4/BC/1/11-S-1R-0-O,0F-G,C3	
B	Basic, not for pressure gauge without heated liquid trap
S	Short, for pressure gauge without heated liquid trap
L	Liquid trap, 230 V, 50/60 Hz, standard connection
M	Liquid trap, 115 V, 50/60 Hz, standard connection
Pressure gauge	
VGA-111-4/BC/1/11-S-1R-0-O,0F-G,C3	
0	Without
1	Pressure gauge, without contact
2	Pressure gauge, contact (R4, closes at falling pressure)
3	Pressure gauge, contact (R5, opens at falling pressure)
Position pressure gauge	
VGA-111-4/BC/1/11-S-1R-0-O,0F-G,C3	
T	Top
R	Right
X	Basic, not for pressure gauge
Flow limiting nozzle	
VGA-111-4/BC/1/11-S-1R-0-O,0F-G,C3	
0	Without
1	With flow limiting nozzle

FilterVGA-111-4/BC/1/11-S-1R-0-O,0F-G,C3O Filter in pressure connection

U Filter in inlet valve

Residual pressure deviceVGA-111-4/BC/1/11-S-1R-0-0,OF-G,C3

0 Without

1 With residual pressure device

Position pressure inletVGA-111-4/BC/1/11-S-1R-0-0,OF-G,C3F Front

L Left

R Right

LogoVGA-111-4/BC/1/11-S-1R-0-0,0F-G,C3G Grundfos**Product certificate**VGA-111-4/BC/1/11-S-1R-0-0,0F-G,C3C3 Certificate 3.1 (EN 10204)

Order data for VGA-111

VGA-111 for cylinder or header-line mounting

- Inlet valve **without** heated liquid trap

Pressure connection	Pressure gauge	Other features	Type designation	Product number	Product number with certificate 3.1
1"	Without		VGA-111-4/BC/1/11-B-0X-0-O,0F-G	96680069	95759869
	With		VGA-111-4/BC/1/11-S-1R-0-O,0F-G	96680135	95759870
	Contact (R4)		VGA-111-4/BC/1/11-S-2R-0-O,0F-G	95723062	95759872
	Contact (R5)		VGA-111-4/BC/1/11-S-3R-0-O,0F-G	95723061	95759874
	With	Residual pressure safety device	VGA-111-4/BC/1/11-S-1R-0-O,1F-G	96680233	95759876
	Contact (R4)		VGA-111-4/BC/1/11-S-2R-0-O,1F-G	96680186	95759877
	Contact (R5)		VGA-111-4/BC/1/11-S-3R-0-O,1F-G	96680115	95759878
	With	Flow limiting nozzle, max 650 g/h	VGA-111-4/BC/1/11-S-1R-1-O,0F-G	96680159	95759880
	Contact (R4)		VGA-111-4/BC/1/11-S-2R-1-O,0F-G	95716850	95759881
	Contact (R5)		VGA-111-4/BC/1/11-S-3R-1-O,0F-G	95703019	95759882
G 3/4	Without		VGA-111-4/BC/2/11-B-0X-0-O,0F-G	96680071	95759883
	With		VGA-111-4/BC/2/11-S-1R-0-O,0F-G	95712192	95759884
	Contact (R4)		VGA-111-4/BC/2/11-S-2R-0-O,0F-G	95759885	95759886
	Contact (R5)		VGA-111-4/BC/2/11-S-3R-0-O,0F-G	95759666	95759887
Yoke USA	Without		VGA-111-4/B/3/11-B-0X-0-O,0F-G	91834644	95759888
	With		VGA-111-4/B/3/11-S-1R-0-O,0F-G	95759889	95759890
	Contact (R4)		VGA-111-4/B/3/11-S-2R-0-O,0F-G	95759891	95759892
	Contact (R5)		VGA-111-4/B/3/11-S-3R-0-O,0F-G	95759893	95759894
G 5/8	With		VGA-111-4/B/9/11-S-1R-0-O,0F-G	95759895	95759896
	Contact (R4)		VGA-111-4/B/9/11-S-2R-0-O,0F-G	95759897	95759898
	Contact (R5)		VGA-111-4/B/9/11-S-3R-0-O,0F-G	95759899	95759900

VGA-111 for drum mounting

- Inlet valve **with** heated liquid trap
- Connection left, pressure gauge top-mounted

Pressure connection	Pressure gauge	Heated liquid trap	Type designation	Product number	Product number with certificate 3.1
Yoke USA	With		VGA-111-4/D/3/11-L-1T-0-U,0L-G	96680201	95759901
	Contact (R4)	230 V, 50/60 Hz	VGA-111-4/D/3/11-L-2T-0-U,0L-G	95759902	95759903
	Contact (R5)		VGA-111-4/D/3/11-L-3T-0-U,0L-G	95759904	95759905
	With			VGA-111-4/D/3/11-M-1T-0-U,0L-G	95759906
	Contact (R4)	115 V, 50/60 Hz	VGA-111-4/D/3/11-M-2T-0-U,0L-G	95759908	95759909
	Contact (R5)		VGA-111-4/D/3/11-M-3T-0-U,0L-G	95759910	95759911
1 1/4"	With		VGA-111-4/D/14/11-L-1T-0-U,0L-G	96680121	95759912
	Contact (R4)	230 V, 50/60 Hz	VGA-111-4/D/14/11-L-2T-0-U,0L-G	96680116	95759913
	Contact (R5)		VGA-111-4/D/14/11-L-3T-0-U,0L-G	95759914	95759915

VGA-111 for header-line mounting

- Inlet valve **with** heated liquid trap
- Pressure gauge top-mounted

Pressure connection	Pressure gauge	Heated liquid trap	Pressure inlet position	Type designation	Product number	Product number with certificate 3.1
1"	With			VGA-111-4/C/1/11-L-1T-0-U,0L-G	96680132	95759917
	Contact (R4)	230 V, 50/60 Hz	Left	VGA-111-4/C/1/11-L-2T-0-U,0L-G	96680139	95759918
	Contact (R5)			VGA-111-4/C/1/11-L-3T-0-U,0L-G	95721695	95759919
	With				VGA-111-4/C/1/11-L-1T-0-U,0R-G	95717322
	Contact (R4)	230 V, 50/60 Hz	Right	VGA-111-4/C/1/11-L-2T-0-U,0R-G	95733061	95759921
	Contact (R5)			VGA-111-4/C/1/11-L-3T-0-U,0R-G	96680101	95759922

Pressure connection	Pressure gauge	Heated liquid trap	Pressure inlet position	Type designation	Product number	Product number with certificate 3.1
G 3/4	With	230 V, 50/60 Hz	Left	VGA-111-4/C/2/11-L-1T-0-U,0L-G	95712206	95759923
	Contact (R4)			VGA-111-4/C/2/11-L-2T-0-U,0L-G	95759924	95759925
	Contact (R5)			VGA-111-4/C/2/11-L-3T-0-U,0L-G	95745834	95759926
	With	230 V, 50/60 Hz	Right	VGA-111-4/C/2/11-L-1T-0-U,0R-G	95758862	95759927
	Contact (R4)			VGA-111-4/C/2/11-L-2T-0-U,0R-G	95759928	95759929
	Contact (R5)			VGA-111-4/C/2/11-L-3T-0-U,0R-G	95759930	95759931

VGA-111 for wall mounting

- Inlet valve **with** or **without** heated liquid trap
- Brackets for wall-mounting included

Pressure connection	Pressure gauge	Other features	Type designation	Product number	Product number with certificate 3.1
G 1/2	With	Without liquid trap	VGA-111-4/W/4/11-S-1R-0-U,0F-G	96680129	95759932
	Contact (R4)		VGA-111-4/W/4/11-S-2R-0-U,0F-G	95759379	95759933
	Contact (R5)		VGA-111-4/W/4/11-S-3R-0-U,0F-G	95719411	95759934
G 1/2	With	With heated liquid trap, 230 V, 50/60 Hz	VGA-111-4/W/4/11-L-1R-0-U,0F-G	96680091	95759935
	Contact (R4)		VGA-111-4/W/4/11-L-2R-0-U,0F-G	95718353	95759936
	Contact (R5)		VGA-111-4/W/4/11-L-3R-0-U,0F-G	95707323	95759937

Supporting plate for VGA-111 (accessory)

The supporting plate is fixed at a wall and intended to hold the VGA-111 during chlorine cylinder exchange.

Dimensions of a supporting plate for VGA-111

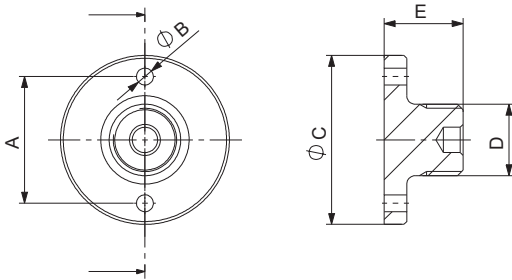

Dimensions in mm

D	A	øB	øC	E
1"				
G 5/8	45	6	60	28
G 3/4				

Order data for a supporting plate for VGA-111

Description	Product number
Supporting plate for VGA-111, connection 1"	96680976
Supporting plate for VGA-111, connection G 3/4	96708811
Supporting plate for VGA-111, connection G 5/8	98025824

5. Dosing regulators

Vaccuperm VGA-113 up to 4 kg/h

VGA-113-110

The VGA 113-110 dosing regulator is used to adjust the chlorine dosing capacity manually. The dosed quantity can be read at the integrated flowmeter. The VGA-113-110 operates under sonic flow conditions without a differential pressure regulator. A VGB injector is required.

The VGA-113-110 dosing regulator is available with the following features:

- Manual capacity adjustment
- Integrated flowmeter (floater principle)
- Various capacities
- Vacuum connections for 8/11 PE hose
- Wall-mounting
- For operation with VGA-111 vacuum regulator



TM075172

VGA-113-311

The VGA-113-311 dosing regulator is used to adjust the chlorine dosing capacity manually. The dosed quantity can be read at the integrated flowmeter. The VGA-113-311 operates with a differential pressure regulator to control the vacuum for a high dosing accuracy. A VGA injector is required.

The VGA-113-311 dosing regulator is available with the following features:

- Manual capacity adjustment
- Integrated flowmeter (floater principle)
- Various capacities
- Vacuum connections for 8/11 PE hose
- Wall-mounting
- For operation with VGA-111 vacuum regulator

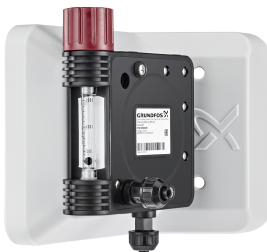

TM075328

VGA-113-311, manual capacity adjustment

VGA-113-391

The VGA-113-391 dosing regulator is used to adjust the chlorine dosing capacity via servomotor. The dosed quantity can be read at the integrated flowmeter. The VGA-113-391 operates with a differential pressure regulator to control the vacuum for a high dosing accuracy. A VGA injector is required.

The VGA-113-391 dosing regulator is available with the following features:

- Manual or automatic capacity adjustment via servomotor
- Integrated flowmeter (float principle)
- Various capacities
- Vacuum connections for 8/11 PE hose
- Wall-mounting
- For operation with VGA-111 vacuum regulator

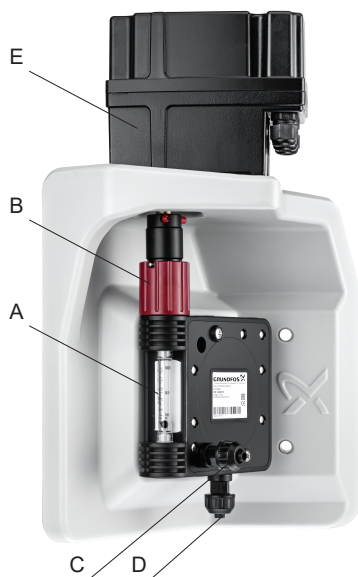

Pos.	Component
A	Flowmeter
B	Adjustment knob
C	Inlet, vacuum connection
D	Outlet, vacuum connection to injector
E	Servomotor

Technical data VGA-113

Medium	Chlorine gas
Capacity	Up to 4000 g/h
Adjustment ratio	1:20
Accuracy	± 4 %
Measuring device	According to the float principle, measuring tube 70 mm
Material	<ul style="list-style-type: none"> • Enclosure: PVC • Springs: alloy C-4, silver-coated • Diaphragm: FEP • Rate valve: PVC • O-rings: FKM
Connections	Vacuum connection: PE hose 8/11 mm
Weight	0.9 kg; 3.1 kg (with servomotor)
Servomotor	<ul style="list-style-type: none"> • Supply voltage: 110-240 V 50/60 Hz or 24 VDC • Input/output signal: 4-20 mA • Enclosure: IP65 • Actuating time (1-100 %): 90 s • Power consumption: 15 VA • Fault relay: potential-free, NC

Dimensions of VGA-113

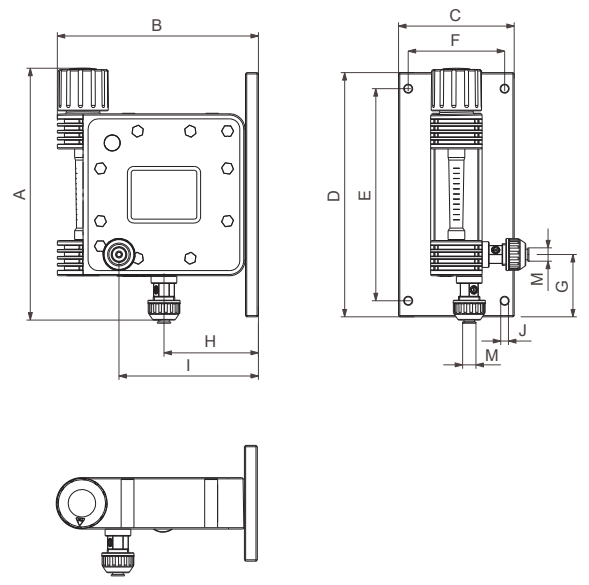

VGA-113-110, manual version

TM074740

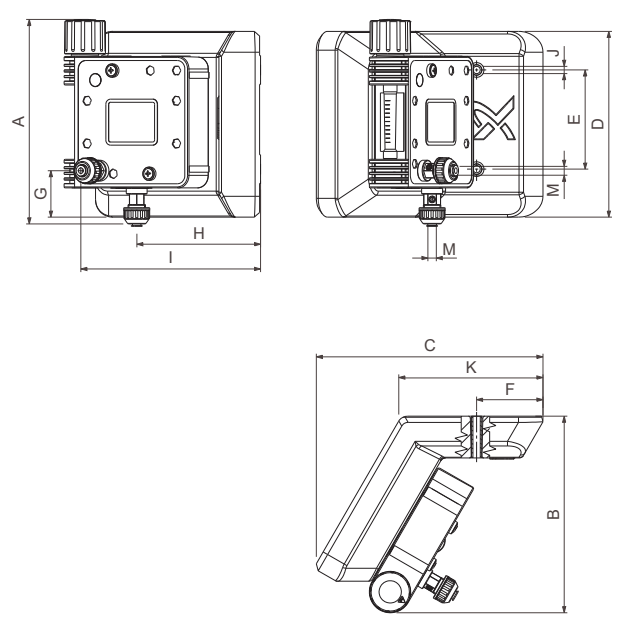

VGA-113-311, manual version

TM074741

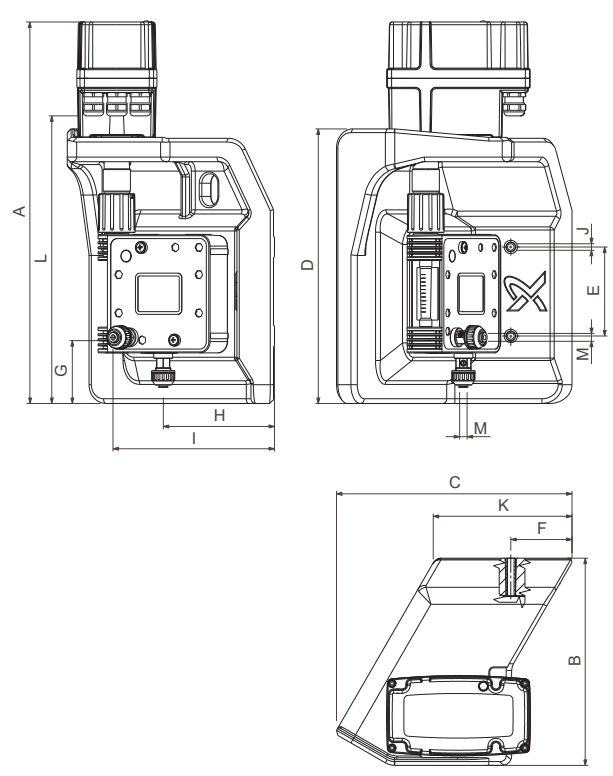

VGA-113-391, automatic version with servomotor

TM074738

Dimensions in mm

Type	A	B	C	D	E	F	G	H	I	J	K	L	M
VGA-113-110	196	156	90	190	165	75	48.5	73	108	6	-	-	8x11
VGA-113-311	196	188	217	178	95	64	44	119	172	7	138	-	8x11
VGA-113-391	407	221	251	293	95	65	70.5	119	172	7	148	307	8x11

Type key VGA-113

Type	
VGA-113 -25/11-M0,Y-G,C3	
VGA-113	Dosing regulator
Capacity	
VGA-113- 25 /11-M0,Y-G,C3	
25	1-25 g/h
40	2-40 g/h
100	5-100 g/h
250	10-250 g/h
500	25-500 g/h
1000	50-1000 g/h
2000	100-2000 g/h
3000	150-3000 g/h
4000	400-4000 g/h
Vacuum connection, inlet/outlet	
VGA-113-25/ 11 -M0,Y-G,C3	
11	PE hose 8/11
Adjustment	
VGA-113-25/11- M0 ,Y-G,C3	
M0	Manual
D3	Automatic, 110-240 V, 50/60 Hz, 4-20 mA
D4	Automatic, 24 VDC, 4-20 mA
Differential pressure regulator	
VGA-113-25/11-M0, Y -G,C3	
N	Without
Y	With
Logo	
VGA-113-25/11-M0,Y- G ,C3	
G	Grundfos
Product certificate	
VGA-113-25/11-M0,Y-G, C3	
C3	Certificate 3.1 (EN 10204)

Order data for VGA-113**VGA-113-110, manual capacity adjustment**

Capacity [g/h]	Type designation	Product number	Product number with certificate 3.1
5-100	VGA-113-100/11-M0,N-G	96680284	95758143
10-250	VGA-113-250/11-M0,N-G	96680286	95759948
25-500	VGA-113-500/11-M0,N-G	96680276	95759949
50-1000	VGA-113-1000/11-M0,N-G	96680275	95759950
100-2000	VGA-113-2000/11-M0,N-G	96680283	95759951
150-3000	VGA-113-3000/11-M0,N-G	96680287	95759952
400-4000	VGA-113-4000/11-M0,N-G	96680281	95759953

VGA-113-311, manual capacity adjustment

Capacity [g/h]	Type designation	Product number	Product number with certificate 3.1
1-25	VGA-113-25/11-M0,Y-G	95722277	95759940
2-40	VGA-113-40/11-M0,Y-G	95722278	95759941
5-100	VGA-113-100/11-M0,Y-G	95722279	95759942
10-250	VGA-113-250/11-M0,Y-G	95722280	95759943
25-500	VGA-113-500/11-M0,Y-G	95722281	95754102
50-1000	VGA-113-1000/11-M0,Y-G	95722282	95759944
100-2000	VGA-113-2000/11-M0,Y-G	95722283	95759945
150-3000	VGA-113-3000/11-M0,Y-G	95722284	95759946
400-4000	VGA-113-4000/11-M0,Y-G	95722285	95759947

VGA-113-391, automatic capacity adjustment

Supply voltage servomotor: 110-240 V, 50/60 Hz

Capacity [g/h]	Type designation	Product number	Product number with certificate 3.1
2-40	VGA-113-40/11-D3,Y-G	95722288	95759938
5-100	VGA-113-100/11-D3,Y-G	95722290	95751801
10-250	VGA-113-250/11-D3,Y-G	95722292	95754454
25-500	VGA-113-500/11-D3,Y-G	95722294	95749040
50-1000	VGA-113-1000/11-D3,Y-G	95722296	95749041
100-2000	VGA-113-2000/11-D3,Y-G	95722298	95749038
150-3000	VGA-113-3000/11-D3,Y-G	95722300	95759939
400-4000	VGA-113-4000/11-D3,Y-G	95722302	95749023

VGA-113-391, automatic capacity adjustment

Supply voltage servomotor: 24 VDC

Capacity [g/h]	Type designation	Product number	Product number with certificate 3.1
2-40	VGA-113-40/11-D4,Y-G	95760293	95760301
5-100	VGA-113-100/11-D4,Y-G	95760294	95760302
10-250	VGA-113-250/11-D4,Y-G	95760295	95760303
25-500	VGA-113-500/11-D4,Y-G	95760296	95760304
50-1000	VGA-113-1000/11-D4,Y-G	95760297	95760305
100-2000	VGA-113-2000/11-D4,Y-G	95760298	95760306
150-3000	VGA-113-3000/11-D4,Y-G	95760299	95760307
400-4000	VGA-113-4000/11-D4,Y-G	95760300	95760308

6. Change-over devices

Change-over devices ensure a continuous supply of a chlorine gas dosing system by changing over from the empty bank of cylinders or drums to the standby bank.

Two types of change over device are available:

- vacuum change-over devices
- pressure change-over devices

Vacuum change-over devices are installed on the vacuum side of a chlorine gas dosing system and are available in 2 options:

- 186: electrically powered
- 189: without electrical power

Pressure change-over devices are installed on the pressure side of a chlorine gas dosing system:

- 185: electrically powered

189 vacuum change-over device

The 189 vacuum change-over device is available for 4 kg/h and 10 kg/h. The 189 vacuum change-over device operates without electrical power. It is a diaphragm-operated system that is triggered by a rising vacuum created by an empty cylinder or drum. The bank of cylinders or drums in duty is indicated visually, optionally this indication can be remotely indicated via 2 reed contacts. The 189 change over device can be used in connection with vacuum regulators and dosing regulators up to 10 kg/h.

The 189 vacuum change-over device includes:

- Visual indication or visual indication with contact for remote indication
- Mounting bracket
- Vacuum connections for PE hose 8/11 (4 kg/h) or PE hose 10/14 (10 kg/h)

Option:

Connections for DN 15 vacuum pipe can be ordered separately (3 per device).



TM075121

Technical data 189

Medium	Chlorine gas
Capacity	4 kg/h and 10 kg/h
Vacuum connections	<ul style="list-style-type: none"> • PE hose 8/11 (4 kg/h) • PE hose 10/14 (10 kg/h) • Optional connection for DN 15 pipe
Reed contact for remote indication	75 VDC, 1 Amp, 50 W
Material	PVC, silver, FEP, glass, silver-coated alloy C, FKM
Weight	2 kg

Dimensions 189

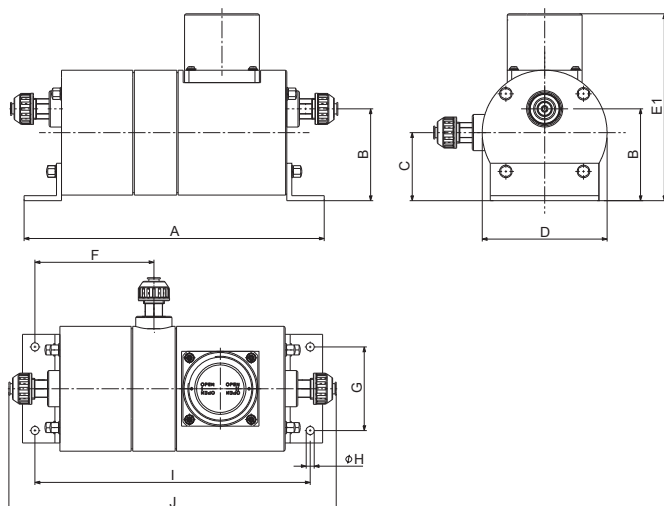

189 change-over device without contact to remote indicator

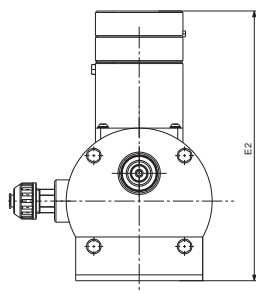

189 change-over device with contact to remote indicator

Dimensions in mm

A	B	C	D	E1	E2	F	G	φH	I	J
241	73	54	100	149	185	95	67	6.5	221	262

TM075040

TM075041

Type key 189

Type	
189 -C-4/11,11/N/0/X,X,0-G,C3	
189	Change-over device
Medium	
189-C-4/11,11/N/0/X,X,0-G,C3	
C	Chlorine
Capacity	
189-C-4/11,11/N/0/X,X,0-G,C3	
4	4 kg/h
10	10 kg/h
Vacuum connection, inlet	
189-C-4/11,11/N/0/X,X,0-G,C3	
6	PE hose 10/14
11	PE hose 8/11
Vacuum connection, outlet	
189-C-4/11,11/N/0/X,X,0-G,C3	
6	PE hose 10/14
11	PE hose 8/11
Contact for remote indication	
189-C-4/11,11/N/0/X,X,0-G,C3	
N	Without
Y	Contact for remote indication
Control cabinet	
189-C-4/11,11/N/0/X,X,0-G,C3	
0	Without
Supply voltage	
189-C-4/11,11/N/0/X,X,0-G,C3	
X	Not electrical
Control cabinet labelling	
189-C-4/11,11/N/0/X,X,0-G,C3	
X	Without control cabinet
Control cabinet version	
189-C-4/11,11/N/0/X,X,0-G,C3	
0	Without control cabinet
Logo	
189-C-4/11,11/N/0/X,X,0-G,C3	
G	Grundfos
Product certificate	
189-C-4/11,11/N/0/X,X,0-G,C3	
C3	Certificate 3.1 (EN 10204)

Order data for 189

189 change-over device up to 4 kg/h

Contact for remote signal transmission	Type designation	Product number	Product number with certificate 3.1
Without	189-C-4/11,11/N/0/X,X,0-G	91834811	95749022
With	189-C-4/11,11/Y/0/X,X,0-G	96681741	95749762

Pipe connection for 189 change-over device (accessory)

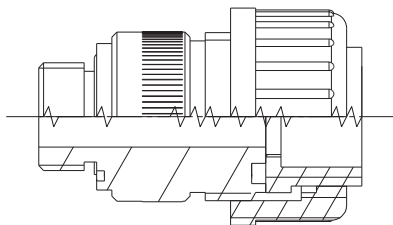

Description	Product number
Pipe connection, DN 15 (1 unit)	99358518

Remote indicator

The remote indicator is operated in conjunction with the 189 vacuum change-over device with contact for remote indication.

If the bank of cylinders or drums in duty is empty, the change-over device switches to the standby bank. The switching status is shown on the remote indicator. LEDs on the remote indicator show the bank of cylinders or drums in duty. Potential-free output signals for bank 1 or 2 empty and general fault are available.



TM075150

Technical data of a remote indicator

Supply voltage	230 V, 50/60 Hz; 115 V, 50/60 Hz
Enclosure	IP65
Input signal	Reed contact from change-over device
Output signal	Relay max. 250 V, 2 A, max. 250 VA

Order data for a remote indicator

Supply voltage	Product number
Remote indicator, 115 V, 50/60 Hz	95715968
Remote indicator, 230 V, 50/60 Hz	95715967

7. Injectors

VGB, VGA, and VGS injectors

Injectors are needed to create the vacuum to transport the chlorine gas into the water.

To select the suitable injector, the following data are required:

- Counterpressure
- Motive water pressure
- Dosing capacity

VGA and VGS injectors are used with dosing regulators with differential pressure regulator. VGB injectors are used with dosing regulators without differential pressure regulator (VGB-103, VGA-113-110, VGA-117).

The injectors are available with the following features:

- Different sizes for the whole Vaccuperm range and counterpressure range
- Different water connections
- Reliable diaphragm non-return valve
- Optional mounting bracket set (VGS injector)

Benefits

- Low operating costs and high efficiency due to the special form of the nozzle.
- Easy selection of the operating point thanks to the optimum graduation of the product range.
- The construction according to the flow allows a reduction of the pressure losses of the non-return diaphragm valve.
- A safety non-return diaphragm valve according to the floater principle protects the dosing unit disposed upstream optimally from the entry of water or chlorine solution.
- Excellent price-performance ratio.

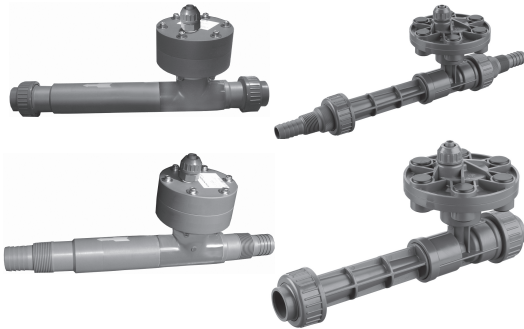

PVC injectors for Vaccuperm gas dosing systems

Technical data of injectors

Technical data

Motive water pressure	See tables with order data
Counterpressure	See tables with order data
Motive water temperature	+5 °C to +30 °C
Ambient temperature	+5 °C to +40 °C
Material	<ul style="list-style-type: none"> • Housing: PVC • Spring: alloy C4, PTFE coated • Diaphragm: FEP • Piston: PTFE

TM074873

Dimensions

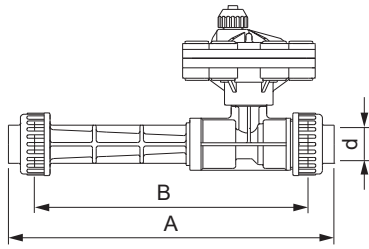

TM074876

VGB injector up to 2 kg/h and VGA injector up to 4 kg/h, connection DN 20

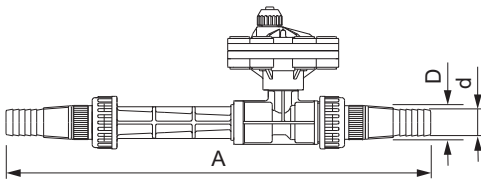

TM074872

VGB injector up to 2 kg/h and VGA injector up to 4 kg/h, connection 3/4" NPT, 1" NPT

Dimensions in mm

d	D	A	B
DN 20	-	275	232
Hose 3/4"	3/4" NPT	400	-
Hose 1"	1" NPT	430	-

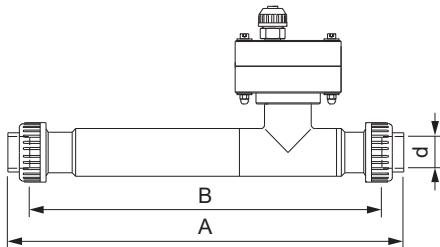

TM074877

VGB injector up to 10 kg/h and VGA up to 10 kg/h, connection DN 25

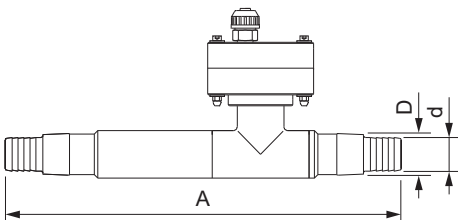

TM074875

VGB injector up to 10 kg/h and VGA injector up to 10 kg/h, connection 1 1/4"

Dimensions in mm

d	D	A	B
DN 25	-	400	350
Hose 1 1/4"	1 1/4" NPT	400	-

Type key of injectors

Type			
545 -C-1/0,5-7/W1,W1-11/NR,C3			
545	Vaccuperm injector		
Medium			
545-C-1/0,5-7/W1,W1-11/NR,C3			
C	Chlorine		
Capacity			
545-C-1/0,5-7/W1,W1-11/NR,C3			
	VGA injector	VGB injector	VGS injector
0.5/0	0.5 kg/h		
1/0.5	1.0 kg/h	0.5 kg/h	
2/1	2.0 kg/h	1.0 kg/h	
4/2	4.0 kg/h	2.0 kg/h	
0/3		3.0 kg/h	
0/4		4.0 kg/h	
Counterpressure			
545-C-1/0,5-7/W1,W1-11/NR,C3			
3	0-3 bar		
6	3-7 bar		
7	0-7 bar		
16	5-16 bar		

8. Pressure-side accessories

Header lines

Header lines connect several chlorine cylinders or drums with the downstream components of the gas dosing system. Header lines include the following:

- a collector pipe for the corresponding number of cylinders or drums
- flexible lines for connecting the cylinders or drums
- the corresponding number of connection valves

Selection of the suitable header line

It is possible to extract 1 % per hour of the content of a chlorine cylinder or drum by weight. The needed number of cylinders or drums can be calculated based on the required total dosing quantity.

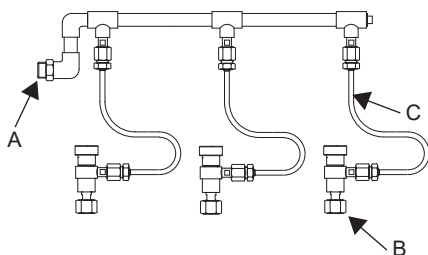

Header line for chlorine cylinders

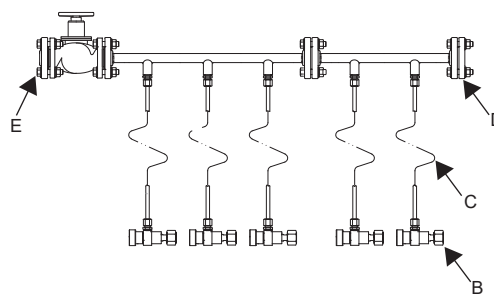

TM075122

TM075123

Header line for 5 drums

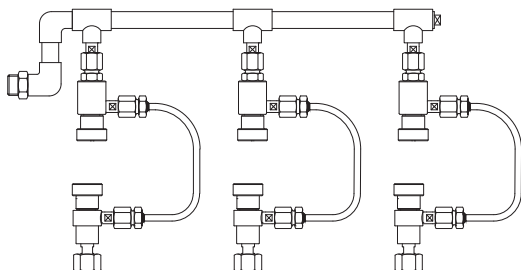

TM078978

Header lines with angle valves

Pos.	Component
A	Connection vacuum regulator
B	Connection cylinder or drum
C	Flexible copper line
D	Connection for nitrogen rinsing device
E	Connection for LiquFilt 524 or 185 change-over device

Technical data of header lines

Medium	Liquid or gaseous chlorine
Max. pressure	16 bar
Material	<ul style="list-style-type: none"> • Pipe: low-carbon steel • Copper line: tin-plated copper • Connection valve: nickel-plated brass, alloy C4, PTFE, FKM

Dimensions of header lines

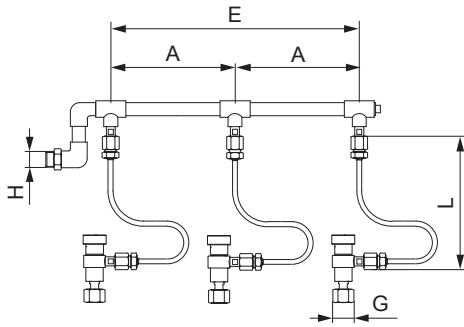

TM074880

Header line for cylinders

Dimensions in mm

Cylinder	A	E	G	H	L
2		700	1"		
3	350	1050	Yoke USA	1"	1000
4		1400			

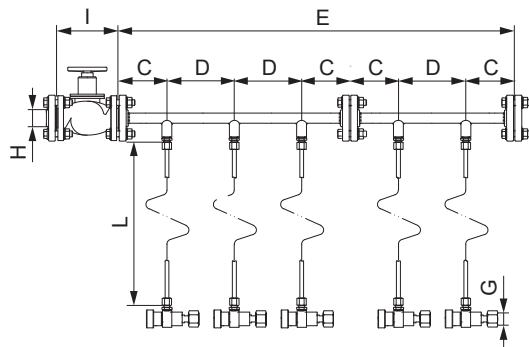
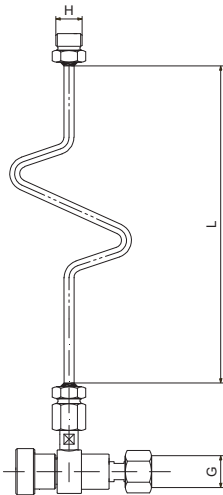

TM075060

Header line for 5 drums

TM075124

Valve connection with copper line for one drum or cylinder

Dimensions in mm

Drums	C	D	E	G	H	I	L
1	-	-	-		G 1/2	-	
2			2000	1"			
3			3000	Yoke USA			
4	500	1000	4000	1 1/4"	Welding neck flange DN 25	160	2000
5			5000				
6			6000				

Type key of header lines

Type	
542 -C-2/1,1-N	
542	Header line
Container type	
542-C-2/1,1-N	
C	Cylinder
D	Drum
Number	
542-C-2/1,1-N	
1	1
2	2
3	3
4	4
5	5
6	6
Connection container	
542-C-2/1,1-N	
1	1"
3	Yoke USA
14	1 1/4"
Connection vacuum regulator	
542-C-2/1,1-N	
1	1"
4	G 1/2
18	Welding neck flange DN 25
Angle valve	
542-C-2/1,1-N	
N	Without
Y	With

Order data for header lines for cylinders without angle valve

Number of cylinders	Cylinder connection 1"		Cylinder connection yoke USA	
	Type designation	Product number	Type designation	Product number
2	542-C-2/1,1-N	96698876	542-C-2/3,1-N	95704437
3	542-C-3/1,1-N	96698877	542-C-3/3,1-N	95715079
4	542-C-4/1,1-N	96698878	542-C-4/3,1-N	95760985

Order data for header lines for cylinders with angle valve

Number of cylinders	Cylinder connection 1"		Cylinder connection yoke USA	
	Type designation	Product number	Type designation	Product number
2	542-C-2/1,1-Y	95700771	542-C-2/3,1-Y	95761564
3	542-C-3/1,1-Y	96728990	542-C-3/3,1-Y	95761565
4	542-C-4/1,1-Y	96728992	542-C-4/3,1-Y	95744505

Order data for header lines for drums

Number of drums	Connection 1"		Connection yoke USA		Connection 1 ¼"	
	Type designation	Product number	Type designation	Product number	Type designation	Product number
1	542-D-1/1,4-N	96728935	542-D-1/3,4-N	95700445	542-D-1/14,4-N	96728936
2	542-D-2/1,18-N	95760905	542-D-2/3,18-N	95760896	542-D-2/14,18-N	95752980
3	542-D-3/1,18-N	95760906	542-D-3/3,18-N	95760897	542-D-3/14,18-N	95760902
4	542-D-4/1,18-N	95760907	542-D-4/3,18-N	95760898	542-D-4/14,18-N	95760903
5	542-D-5/1,18-N	95760908	542-D-5/3,18-N	95760899	542-D-5/14,18-N	95760904
6	542-D-6/1,18-N	95760900	542-D-6/3,18-N	96760900	542-D-6/14,18-N	95760901

Copper line

The copper line connects the chlorine container with the header line or vacuum regulator. A connection valve is required between the chlorine container and the copper line.

Technical data of a copper line

Medium	Chlorine
Max. pressure	16 bar
Material	Copper, tin-plated Brass, tin-plated

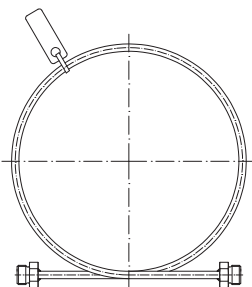

TM075133

Order data for a copper line

Description	Product number
1 metre of copper line with G 1/2 connectors	99356968
2 metres of copper line with G 1/2 connectors	99356984
5 metres of copper line with G 1/2 connectors	96680970

Corner valve for header line

The corner valve is used as a shut-off valve between the copper line and the header line.

Technical data of a corner valve

Medium	Chlorine (liquid or gas)
Max. pressure	16 bar
Material	<ul style="list-style-type: none"> Valve body: brass, nickel-plated Valve piston: nickel-chrome alloy Gaskets: IT, asbestos-free Packing: PTFE O-ring: FKM

Dimensions of a corner valve

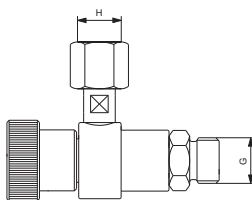

TM075046

G (inlet)	H (outlet)
G 1/2	G 1/2

Order data for a corner valve

Description	Product number
Corner valve	96729263

Connection valve for cylinder and drum

The connection valve is used as a shut-off valve between the chlorine cylinder or drum and the copper line.

Technical data of a connection valve

Medium	Chlorine (liquid or gas)
Max. pressure	16 bar
Material	<ul style="list-style-type: none"> Valve body: brass, nickel-plated Valve piston: nickel-chrome alloy Gasket: IT, asbestos-free Packing: PTFE O-ring: FKM

Dimensions of a connection valve

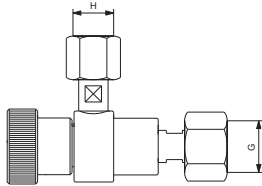

TM075047

Description	G (inlet)	H (outlet)
Connection valve 1"	1"	G 1/2
Connection valve G 3/4	G 3/4	G 1/2
Connection valve 1 1/4"	1 1/4"	G 1/2

Order data for a connection valve

Description	Product number
Connection valve 1"	96690367
Connection valve G 3/4	96688687
Connection valve 1 1/4"	96690368

Connection screwing for connection valve

The connection screwing is used to adapt the connection valve to different connection sizes of chlorine containers.

Dimensions of a connection screwing for connection valve

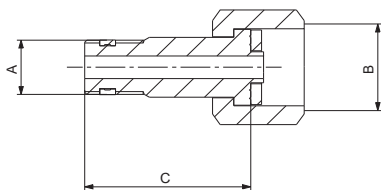

TM075053

Dimensions in mm

A	B	C
G 1/4	G 1/2	39
	1"	36
	G 3/4	61
	1 1/4"	49

Order data for a connection screwing for connection valve

Description	Product number
Connection screwing G 1/2	96729262
Connection screwing 1"	99707722
Connection screwing G 3/4	99709506
Connection screwing 1 1/4"	99707747

Adapter flange for VGA-146 vacuum regulator

The adapter flange connects the VGA-146 vacuum regulator with the header line for chlorine drums.

Dimensions of an adapter flange for VGA-146

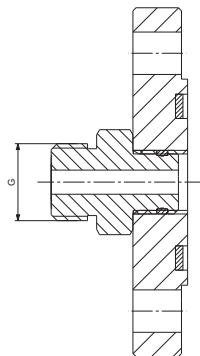

TM075083

Description	G
Adapter flange (groove flange), DN 25	1"

Order data for an adapter flange for VGA-146

Description	Product number
Adapter flange (groove flange), DN 25 (EN 1092-1), with 1" connection and flat gasket	99656316

Adapter flange for copper line

The adapter flange connects the copper line with the header line for chlorine drums.

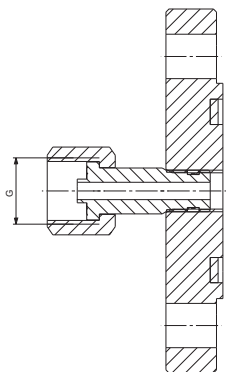

TM075080

Description	G
Adapter flange (groove flange) DN 25	G 1/2

Order data for an adapter flange for copper line

Description	Product number
Adapter flange (groove flange) DN 25, PN40 (EN 1092-1) with G 1/2 connection and flat gasket	99656301

Nitrogen rinsing device

Order data for a nitrogen rinsing device

The nitrogen rinsing device is used to flush the chlorine gas dosing system with nitrogen for removing the chlorine gas before working on the system. With the tongue flange the nitrogen rinsing device is connected to the header line for chlorine drums.

The nitrogen rinsing device is available with:

- 40-litre nitrogen cylinder (empty)
- Pressure reducing valve
- 2 metres of copper line
- Corner valve
- DN 25 tongue flange and flange gasket

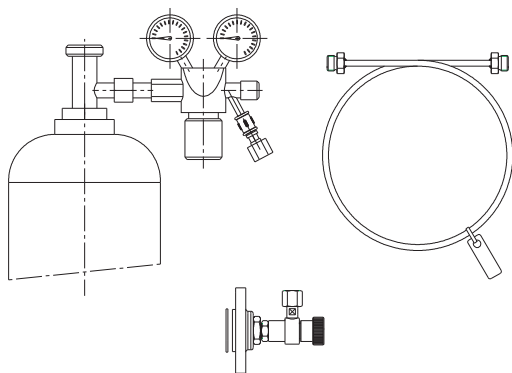

TM075184

Description	Product number
Nitrogen rinsing device for connection to DN 25 header lines for chlorine drums	96726855

9. Vacuum-Side Accessories

Chlorine gas adsorption filter

Technical data of a chlorine gas adsorption filter

The chlorine gas adsorption filter is installed at the vent outlet of the vacuum regulator. In case of a malfunction of the vacuum regulator, the adsorption filter neutralises the chlorine gas.

Medium	Chlorine gas
Adsorption capacity	Approximately 450 g Cl ₂
Inner filter volume	5 l
Material	<ul style="list-style-type: none"> • Enclosure: PVC • Adsorbent: aluminium oxide
Connections	PE hose 8/11
Filling weight	4 kg

Dimensions of a chlorine gas adsorption filter

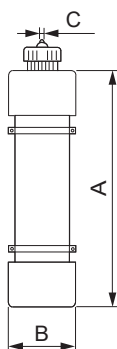

Dimensions in mm

A	B	C
824	139	8/11

Order data for a chlorine gas adsorption filter

Description	Product number
Chlorine gas adsorption cylinder, filled	96696580
Refilling (4 kg adsorbent)	96688989

Vacuum non-return valve

The vacuum non-return valve prevents water backflow from the injector to the dosing regulator.

Technical data of a vacuum non-return valve

Medium	Chlorine gas
Capacity	up to 4 kg/h
Material	<ul style="list-style-type: none"> • Valve body: PVC • Spring: Tantal • Ball: glass • O-ring: FKM
Vacuum connections	PE hose 8/11
Opening pressure	0.05 bar

TM074620

Dimensions of a vacuum non-return valve

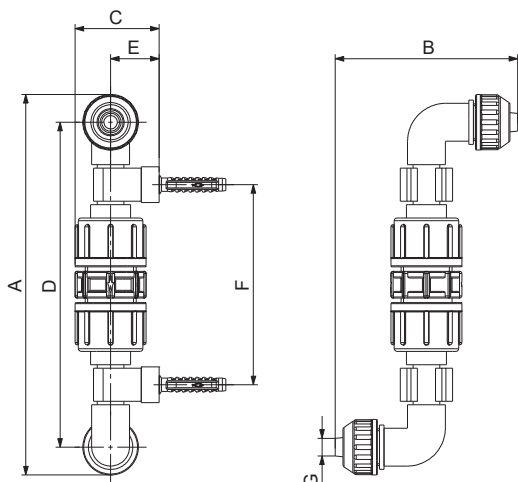

TM075049

Dimensions in mm

A	B	C	D	E	F	G
171	82	38	146	22	90+2	8

Order data for a vacuum non-return valve

Description	Product number
Vacuum non-return valve	95704851

Anti-syphoning valve

The anti-syphoning valve is installed between the booster pump and the injector. If the injection point is lower than the water unit, the anti-syphoning valve prevents syphoning when the chlorine gas dosing system is stopped.

Technical data of an anti-syphoning valve

Medium	Water
Material	<ul style="list-style-type: none"> Housing: PVC Spring: Tantal Ball: glass O-ring: FKM
Connection	Piping DN 20
Opening pressure	0.05 bar

Dimensions of an anti-syphoning valve

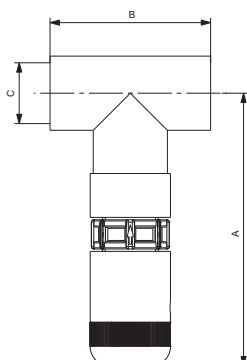

TM075048

Dimensions in mm

A	B	C
112	66	25

Order data for an anti-syphoning valve

Description	Product number
Anti-syphoning valve	96701817

PE hose

PE hoses are installed at the vacuum side of chlorine gas dosing systems up to 10 kg/h. They are available in different lengths and in sizes.

Order data for PE hose

Description	Product number
8/11 mm PE hose, 10 m	96701705
8/11 mm PE hose, 25 m	96695982
8/11 mm PE hose, 50 m	96727461
10/14 mm PE hose, 10 m	91836646
10/14 mm PE hose, 25 m	96727466
10/14 mm PE hose, 50 m	96697538

Connectors

With these connectors, PE hoses or PVC pipes of different sizes can be connected. The threaded side includes a gasket.

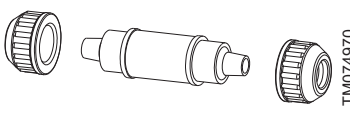
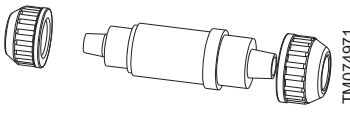
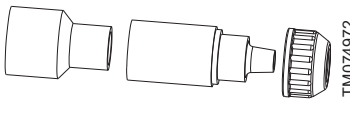
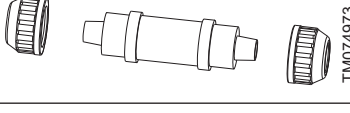
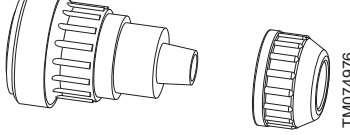
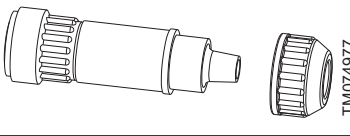
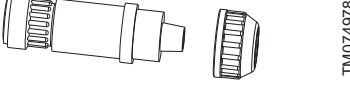
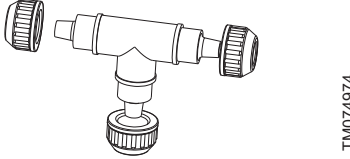
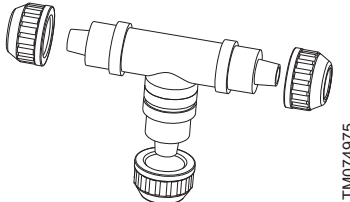
Type	Connection	Material		Product number
		Body and connection	Gasket	
	PE hose 8/11 - PE hose 8/11	PVC	-	99615613
	PE hose 8/11 - PE hose 10/14	PVC	-	99618453
	PE hose 8/11 - PVC pipe DN 10 or DN 15	PVC	-	96727463
	PE hose 10/14 - PE hose 10/14	PVC	-	99618472
	PE hose 10/14 - G 1	PVC	FKM	99628317
	PE hose 8/11 - G 5/8	PVC	FKM	99627276
	PE hose 10/14 - G 5/8	PVC	FKM	99626713
	T-piece for PE hoses 8/11	PVC	-	96695978
	T-piece for PE hoses 10/14	PVC	-	91835711

Contact vacuum meter with PE hose connector

The contact vacuum meter indicates the injector vacuum. The min/max contact can be used for an alarm. The contact vacuum meter is supplied with wall fixing material.

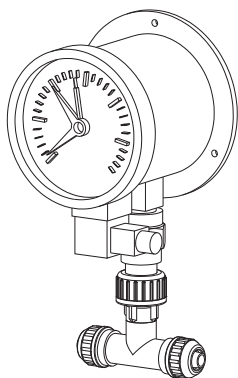

TM075054

Technical data contact vacuum meter

Medium	Chlorine gas
Material	<ul style="list-style-type: none"> • Body and connection: PVC, brass • Gasket: FKM
Vacuum connections	PE hose 10/14
Contacts	Min./Max.

Order data for contact vacuum meter

Description	Product number
Contact vacuum meter, 2 connections for PE hose 10/14, 2 contacts (min/max)	96728932

Ball valve

The ball valve is used to shut-off the vacuum line. The ball valve is supplied with wall fixing material.

Technical data of a ball valve

Medium	Chlorine gas
Capacity	Up to 10 kg/h
Vacuum connection	PE hose: 8/11 or 10/14
Material	<ul style="list-style-type: none"> • Body and connection: PVC • Gaskets: FKM

Dimensions of a ball valve

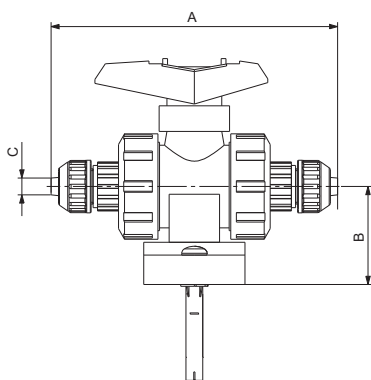

TM075078

Dimensions in mm

Connection	A	B	C
PE hose 8/11	136	46.5	8
PE hose 10/14	147	46.5	10

Order data for a ball valve

Description	Product number
Ball valve for PE hose 8/11	96727449
Ball valve for PE hose 10/14	96727450

10. General accessories

Water unit

The water unit is a device for the regulation or control of the motive water pressure at the injector. The water unit is installed in the motive water line before the injector and must only be used with the VGA-113 dosing regulator.

Technical data of a water unit

Max. pressure	10 bar
Material	Brass, NBR, FKM, PVC

Dimensions of a water unit

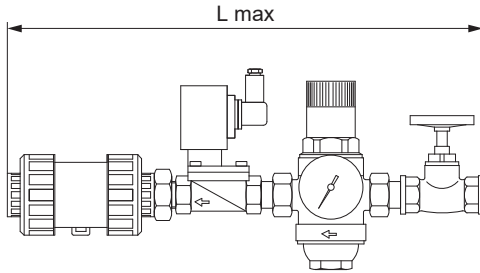

TM074634

Water unit with shut-off valve, solenoid valve, pressure reducing valve, strainer, pressure gauge and non-return valve

Inlet connection	Outlet connection	L _{max} [mm]
G 1/2	PVC pipe 20/25	375
G 1	PVC pipe 25/32	470

Type key of a water unit

Type	
556	-SVPRNV-G1/2-PVC, DN20, 230V50Hz, C3
556	Water unit
Version	
556- SVPRNV -G1/2-PVC, DN20, 230V50Hz, C3	
SVPRNV	Solenoid valve, pressure reducing valve, non-return valve
Water connection, inlet	
556-SVPRNV- G1/2 -PVC, DN20, 230V50Hz, C3	
G 1/2	G 1/2
G 1	G 1
Water connection, outlet	
556-SVPRNV-G1/2- PVC, DN20 , 230V50Hz, C3	
PVC, DN 20	PVC pipe DN 20 (20/25)
PVC DN 25	PVC pipe DN 25 (25/32)
Supply voltage	
556-SVPRNV-G1/2-PVC, DN20, 230V50Hz , C3	
230 V 50 Hz	230 V, 50 Hz
24 VDC	24 VDC
Product certificate	
556-SVPRNV-G1/2-PVC, DN20, 230V50Hz, C3	
C3	Certificate 3.1 (EN 10204)

Order data for a water unit

Connection, inlet	Voltage	Type designation	Product number	Product number with certificate
G 1/2	230 V, 50 Hz	556-SVPRNV-G1/2-PVC, DN20, 230V50Hz	95703314	95760360
	24 VDC	556-SVPRNV-G1/2-PVC, DN20, 24VDC	95721164	95760361
G 1	230 V, 50 Hz	556-SVPRNV-G1-PVC, DN25, 230V50Hz	95704696	95760362
	24 VDC	556-SVPRNV-G1-PVC, DN25, 24VDC	95745342	95760363

Non-return valve for high-pressure injector

The non-return valve for high-pressure injector is installed between the flanges of the injector and the motive water pump to prevent the backflow of chlorine solution to the motive water pump.

Technical data of a non-return valve

Max. pressure	40 bar
Material	Alloy C-4

Dimensions of a non-return valve

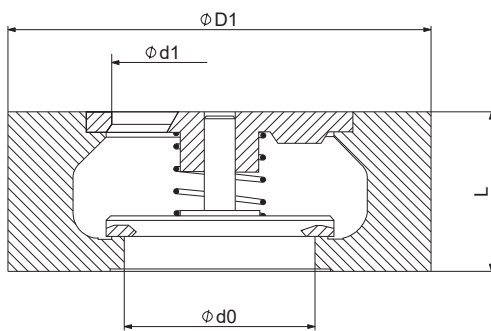

TM075082

Connection size	L	$\phi d1$	$\phi D1$	$\phi d0$
	[mm]	[mm]	[mm]	[mm]
DN 25	35.5	30	71	25

Order data for a non-return valve

Description	Product number
Spring-loaded non-return valve DN 25, PN 40, alloy C-4	95717963

Chlorine cylinder holding clip

The chlorine cylinder holding clip is intended for chlorine cylinders with a diameter of 270 mm. It is mounted on the wall and holds the chlorine cylinder safely in its position in the chlorine room.

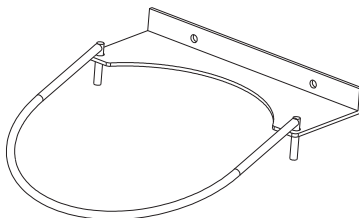

TM075179

Technical data of a chlorine cylinder holding clip

Chlorine cylinder diameter size	270 mm
Material	Painted steel

Order data for a chlorine cylinder holding clip

Description	Product number
Chlorine cylinder holding clip	96726838

Chlorine cylinder scale

The chlorine cylinder scale monitors the weight of the chlorine cylinder and displays the result locally or remotely.

Technical data of a chlorine cylinder scale

Chlorine cylinder size	Diameter 270 mm, max. 100 kg
Output signal	4-20 mA
Power supply	24 VDC

Dimensions of a chlorine cylinder scale

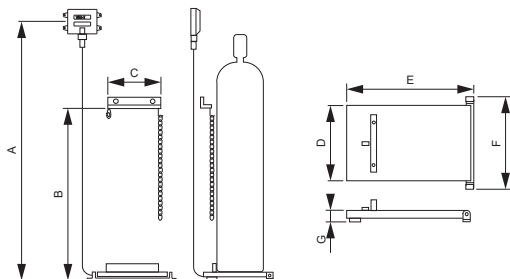

TM078897

Dimensions in mm

A	B	C	D	E	F	G
1525	990-1040	255	420	345	470	42

Order data for a chlorine cylinder scale

Description	Product number
Chlorine cylinder scale for one cylinder up to 100 kg, with signal output 4-20 mA	92546463
Chlorine cylinder scale (2 scales) for two cylinders up to 100 kg each, with signal output 4-20 mA	92546466

Exhauster fan

Dimensions of an exhauster fan

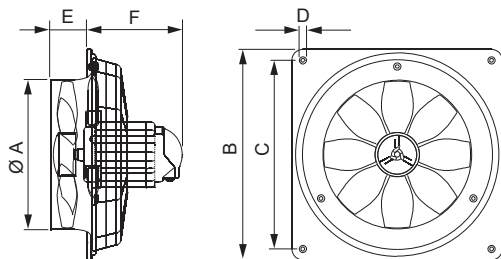

TM075293

Dimensions in mm

Description	A	B	C	D	E	F
Exhauster fan 1150 m ³ /h	217	345	305	8.5	44.5	193
Exhauster fan 2500 m ³ /h	431	580	520	11	100	166
Exhauster fan 5700 m ³ /h	543	700	640	11	137	192

Order data for an exhauster fan

- 3-phase, 400 V, 50 Hz, IP55, with cover

Description	Product number
Exhauster fan 1150 m ³ /h, 65 W, 0.17 A	96726997
Exhauster fan 2500 m ³ /h, 110 W, 0.30 A	96726998
Exhauster fan 5700 m ³ /h, 210 W, 0.65 A	96726999

Chlorine gas neutralisation system (scrubber)

The gas neutralisation system is exclusively intended for neutralisation of chlorine gas in case of a chlorine leakage in the chlorine storage room. The chlorine gas neutralisation system is designed for operation during an emergency case only. An external gas warning device is connected to gas sensors. If the measured gas concentration is higher than the acceptable limit, the gas warning system sends a signal to start the neutralisation system. The contaminated air is sucked through the towers from the bottom to the top. Caustic soda is pumped and sprayed through the towers from the top to the bottom.

The chlorine gas neutralisation system consists of:

- 2 towers filled with Raflux rings
- NaOH storage tank
- NaOH recirculation
- extraction fan
- piping, fittings and valves for a scrubber

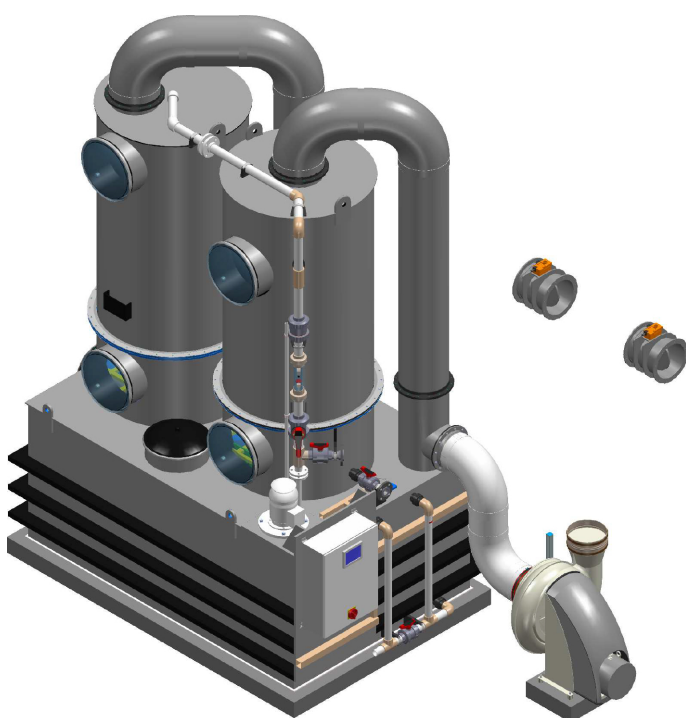

TM075308

Order data for a chlorine gas neutralisation system (scrubber)

Description	Product number
Chlorine gas neutralisation system (scrubber) for cylinder up to 200 kg	on request
Chlorine gas neutralisation system (scrubber) for 1 drum, max. 1000 kg	on request

Compressed-air respirator

Order data for a compressed-air respirator

Description	Product number
Compressed-air respirator with automatic lung and panorama mask, 6-litre cylinder, 300 bars, with supporting frame	96727001
Spare cylinder	96727002

Protective PVC suit

Order data for a protective PVC suit

Description	Product number
Protective PVC suit with vulcanized boots and gloves	96727018

Gas mask

Order data for a gas mask

Description	Product number
Gas mask with threaded filter, type 900 St B 2-P2 (DIN 3181)	96727010
Spare filter for gas mask	96688099
Storage box for gas mask and filter, with shoulder strap	96727011

Rubber gloves

Order data for rubber gloves

Description	Product number
Rubber gloves	96727012

Rubber apron

Order data for a rubber apron

Description	Product number
Rubber apron	96727013

Protective goggles

Order data for protective goggles

Description	Product number
Protective goggles	96727014

Body and eye shower

Dimensions of a body and eye shower

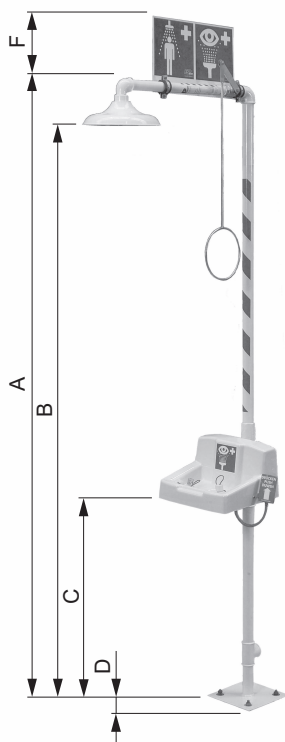

Dimensions in mm

A	B	C	D	E
2269	2115	1000	200	207

Order data for a body and eye shower

Description	Product number
Body and eye shower	96727019

TM075161

Warning signs

Order data for warning signs

Description	Product number
Set of warning signs for a chlorine gas plant in German	96699631
Set of warning signs for a chlorine gas plant in English	96727016

Conex DIA-G gas warning system

The Conex DIA-G gas warning system monitors chlorine gas dosing systems and chlorine storage rooms with up to two potentiostatic sensors.

- Two output signals 4-20 mA
- Two relays (limit values) per sensor
- One alarm relay
- Sensor recognition and autocalibration



TM075162

Order data for Conex DIA-G

Type designation		Voltage	Product number
Conex DIA-G-P. CLP-X-X.W-J	1 sensor	110/240 V, 50/60 Hz	95700080
Conex DIA-G-P. CLP-CLP-X.W-J	2 sensors	110/240 V, 50/60 Hz	95700483

For more detailed information on Conex DIA-G see the data booklet Conex DIA-G, DIS-G.

Battery backup, horn and flashlight

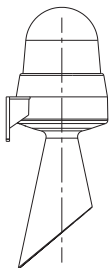

TM075183

Order data for battery backup, horn and flashlight

Designation	Description	Product number
Battery backup	<ul style="list-style-type: none"> • Integrated battery charging unit with I/U charging characteristic • Battery management with micro controller • Temperature regulation of charging voltage by sensor module • Input voltage of the battery controller 115/230 V (50/60 Hz) • Input current, 0.84 A/115 V to 0.42 A/230 V • Max. switch-on current, 2 A/2 ms • Maintenance-free lead-acid battery, 24 V/7 Ah • Buffer time for operation with two sensor interfaces: >1 h 	96725709
Red flashlight with horn	24 VDC, 320 mA, IP33, 92 dB	98037506
Red flashlight with horn	230 V, 50/60 Hz, 50 mA, IP33, 92 dB	96730197

10. Grundfos Product Center

Online search and sizing tool to help you make the right choice.

From the international view, you can select your specific country to view the product range available to you.

International view: <http://product-selection.grundfos.com>

All the information you need in one place

Performance curves, technical specifications, pictures, dimensional drawings, motor curves, wiring diagrams, spare parts, service kits, 3D drawings, documents, system parts. The Product Center displays any recent and saved items - including complete projects - right on the main page.

Downloads

On the product pages, you can download installation and operating instructions, data booklets, service instructions, etc., in PDF format.

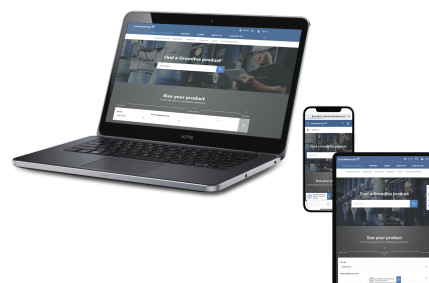

When you select your country, you will see the menus below. Note that some menus may not be available depending on the country.

Example: <https://product-selection.grundfos.com/uk>

Pos.	Description
1	Products & services enables you to find products and documents by typing a product number or name into the search field.
2	Applications enables you to choose an application to see how Grundfos can help you design and optimise your system.
3	Products A-Z enables you to look through a list of all the Grundfos products.
4	Categories enables you to look for a product category.
5	Liquids enables you to find pumps designed for aggressive, flammable or other special liquids.
6	Product replacement enables you to find a suitable replacement.
7	WWW enables you to select the country, which changes the language, the available product range and the structure of the website.
8	Sizing enables you to size a product based on your application and operating conditions.

