

DTS

Dosing tank stations

Installation and operating instructions



Original installation and operating instructions.

CONTENTS

	Page
1. Limited warranty	2
2. Safety instructions	3
2.1 Purpose of this manual	3
2.2 Identification of notices	3
2.3 Qualification and training of personnel	3
2.4 Safety notices for the operating company/operator	3
2.5 Safety notices for maintenance, inspection and installation work	3
3. Product introduction	4
3.1 Intended use	4
3.2 Identification	4
4. Technical data	6
4.1 Operating conditions	6
4.2 Electrical data	6
4.3 Hydraulic data	6
4.4 Dimensions	7
4.5 Materials in contact with media	9
5. Structure and function	10
5.1 Product overview	10
6. Commissioning	11
6.1 Transport and storage	11
6.2 Installation	11
6.3 Tightness check	12
6.4 Electrical connection	12
7. Operation	13
8. Maintenance	13
8.1 Cleaning	13
8.2 Service	13
9. Accessories, spare parts	13
10. Disposal	13
11. Appendix	13
11.1 Documentation enclosed	13
11.2 Other documentation	13

**Warning**

Prior to installation, read these installation and operating instructions. Installation and operation must comply with local regulations and accepted codes of good practice.

**Warning**

Read the installation and operating instructions of the components used.

1. Limited warranty

Products manufactured by GRUNDFOS PUMPS CORPORATION (Grundfos) are warranted to the original user only to be free of defects in material and workmanship for a period of 24 months from date of installation, but not more than 30 months from date of manufacture. Grundfos' liability under this warranty shall be limited to repairing or replacing at Grundfos' option, without charge, F.O.B. Grundfos' factory or authorized service station, any product of Grundfos' manufacture. Grundfos will not be liable for any costs of removal, installation, transportation, or any other charges which may arise in connection with a warranty claim. Products which are sold but not manufactured by Grundfos are subject to the warranty provided by the manufacturer of said products and not by Grundfos' warranty. Grundfos will not be liable for damage or wear to products caused by abnormal operating conditions, accident, abuse, misuse, unauthorized alteration or repair, or if the product was not installed in accordance with Grundfos' printed installation and operating instructions.

To obtain service under this warranty, the defective product must be returned to the distributor or dealer of Grundfos' products from which it was purchased together with proof of purchase and installation date, failure date, and supporting installation data. Unless otherwise provided, the distributor or dealer will contact Grundfos or an authorized service station for instructions. Any defective product to be returned to Grundfos or a service station must be sent freight prepaid; documentation supporting the warranty claim and/or a Return Material Authorization must be included if so instructed.

GRUNDFOS WILL NOT BE LIABLE FOR ANY INCIDENTAL OR CONSEQUENTIAL DAMAGES, LOSSES, OR EXPENSES ARISING FROM INSTALLATION, USE, OR ANY OTHER CAUSES. THERE ARE NO EXPRESS OR IMPLIED WARRANTIES, INCLUDING MERCHANTABILITY OR FITNESS FOR A PARTICULAR PURPOSE, WHICH EXTEND BEYOND THOSE WARRANTIES DESCRIBED OR REFERRED TO ABOVE.

Some jurisdictions do not allow the exclusion or limitation of incidental or consequential damages and some jurisdictions do not allow limit actions on how long implied warranties may last. Therefore, the above limitations or exclusions may not apply to you. This warranty gives you specific legal rights and you may also have other rights which vary from jurisdiction to jurisdiction.

2. Safety instructions

2.1 Purpose of this manual

These installation and operating instructions, along with the relevant component instructions, contain all the information needed to commission and operate the DTS dosing tank station.

If you require further information or should problems arise which are not described in detail in this manual, please contact your nearest Grundfos branch.

2.2 Identification of notices

Information on the system itself, e.g. identification of fluid connections, must be clearly legible at all times.

2.2.1 Symbols used in this document



Warning

If these safety instructions are not observed, it may result in personal injury.



If these safety instructions are not observed, it may result in malfunction or damage to the equipment.

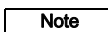

Notes or instructions that make the job easier and ensure safe operation.

2.3 Qualification and training of personnel

The personnel responsible for operation, maintenance, inspection and installation must be suitably qualified for this work. Areas of responsibility, responsibilities and supervision of personnel must be strictly controlled by the operating company.

If the personnel do not have the necessary knowledge, they must be trained and instructed accordingly. If necessary, the training can be provided by the manufacturer/supplier at the request of the operator of the pump. The operating company must ensure that personnel understand the content of this manual.

2.4 Safety notices for the operating company/operator

Dangerous hot or cold system parts must be protected to prevent accidental contact.

Any protection against accidental contact used for moving parts must not be removed when the system is operated.

Escaping hazardous media (e.g. hot, toxic) must be diverted such that they do not represent a hazard to people's health or the environment. Statutory regulations must be observed.

2.5 Safety notices for maintenance, inspection and installation work

The operating company must ensure that all maintenance, inspection and installation work is carried out by authorized, qualified personnel who have been appropriately trained.

All work on the system may only be undertaken with the system stopped. The procedures described in this manual for bringing the system to a stop must be followed.

System parts which contain media hazardous to health must be decontaminated.

All safety and protection equipment must be put back into operation as soon as work is completed.

Observe the points described in Section 6. *Commissioning* prior to recommissioning.



Warning

Ensure that the system is suitable for the dosing medium used.

Observe the safety regulations provided by the manufacturer of the chemicals used.



Warning

Repairs must be carried out by authorized and qualified personnel.

Wear protective clothing (gloves and goggles) when working on the system, connections or lines.



The resistance of the parts that come into contact with media depends on the medium, media temperature and operating pressure.

Ensure that parts in contact with the media are chemically resistant to the dosing medium under operating conditions.

3. Product introduction

DTS dosing tank stations include a tank with optional equipment and optional preparation for the specified Grundfos dosing pump, see [3.2.2 Type key](#).

3.1 Intended use

- DTS dosing tank stations are intended for storing and dosing certain liquid dosing media.
- The operating safety of DTS dosing tank stations is only ensured, if used in accordance with the values mentioned in section [4. Technical data](#). The specified limit values must not be exceeded.
- DTS dosing tank stations may only be operated by technical personnel in accordance with the installation and operating instructions.
- Modifications or changes to DTS dosing tank stations are only permitted with the consent of the manufacturer. Original spare parts and accessories approved by the manufacturer are safe to use.



Warning

Any usage other than that described here is not intended. Grundfos accepts no liability for any damage resulting from incorrect use.

3.1.1 Foreseeable misuse

- DTS dosing tank stations are not intended for dosing explosive, gaseous, highly viscous, solid media, or media with abrasive or long-fiber components. Observe the characteristics of the dosing medium under operating conditions.
- DTS dosing tank stations are not intended for operation in other conditions than described in section [4. Technical data](#).

3.2 Identification

3.2.1 Nameplate

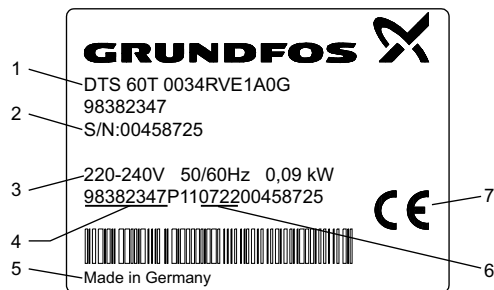

Fig. 1 DTS nameplate

Item	Description
1	Type designation
2	Serial number
3*	Voltage [V]
	Frequency [Hz]
	Power rating [kW]
4	Product number
5	Country of manufacture
6	Code for year and week
7*	Marks of approval, CE mark, etc.

* DTS with electric stirrers

3.2.2 Type key

Example DTS 26G T 1 0 3 4 RE F 4 A 1 H

Product type

DTS Dosing Tank Station

Tank size

15G 15 Gallons (60 liters)
 26G 26 Gallons (100 liters)
 52G 52 Gallons (200 liters)
 79G 79 Gallons (300 liters)
 132G 132 Gallons (500 liters)
 264G 264 Gallons (1000 liters)

Tank colour

T Transparent
 B Black

Collecting tray

0 Without
 1 Collecting tray

Screw cover

0 Black screw cover without lock

Mixer or stirrer

0 Without
 1 Handheld mixer PE
 2 Electric stirrer, stainless steel
 3 Electric stirrer, PP, with sealing flange

Preparation for dosing pump

0 Without
 1 Preparation for DMX 221 up to 13.21 gph (50 l/h)
 3 Preparation for DDI 60-10
 4 Preparation for Smart Digital DDA, DDC, DDE

Multi-function valve

A Without
 G Multi-function valve PV/V
 H Multi-function valve PV/E
 I Multi-function valve PV/T

Filling device

0 Without
 1 Filling armature PVC/E with ball valve
 2 Dissolving hopper

Drain valve

A Without
 B Drain valve PVC/E

Injection unit with 1/2" NPT process connection

0 Without
 1 Injection unit PVC/V/C
 2 Injection unit PP/V/C
 3 Injection unit PVC/E/C
 4 Injection unit PP/E/C
 5 Injection unit PVC/T/C

Discharge line

F 33 ft (10 m) PE-tubing 0.17"x1/4" (up to 2 gph (7.5 l/h))
 G 33 ft (10 m) PE-tubing 9/12 mm 1/4"x3/8" (up to 8 gph (30 l/h))
 H 33 ft (10 m) PE-tubing 6/9 mm (up to 15.8 gph (60 l/h))

Suction line

WO Without
 RV Rigid suction lance (RSL) PE/V
 RE Rigid suction lance (RSL) PE/E
 RT Rigid suction lance (RSL) PE/T
 FV Flexible suction line with foot valve (FV) PE/V
 FE Flexible suction line with foot valve (FV) PE/E
 FT Flexible suction line with foot valve (FV) PE/T

3.2.3 Material key

Pos.	Description
PVC	Polyvinyl chloride
PP	Polypropylene
PE	Polyethylene
V	FKM
E	EPDM
T	PTFE
C	Ceramic
PV	PVDF

4. Technical data

4.1 Operating conditions

The resistance of the parts that come into contact with media depends on the medium, media temperature and operating pressure.

Caution

Ensure that parts in contact with the media are chemically resistant to the dosing medium under operating conditions.

4.1.1 Dosing tank

- Min./Max. storage temperature:
-4 °F to +122 °F (-20 °C to +50 °C)
- Min./Max. ambient temperature:
-4 °F to +113 °F (-20 °C to +45 °C)
- Min./Max. liquid temperature:
-4 °F to +113 °F (-20 °C to +45 °C)
– Dosing medium must be in the liquid phase.

Intended for thin (max. 200 cP [200 mPas]), non-explosive dosing media without abrasive or long-fiber components. The dosing medium must not chemically attack the materials of the DTS dosing tank station.

4.1.2 Components

Note

For the below mentioned operating conditions, refer to the installation and operating instructions of the components used.

- Min. /Max. storage temperature
- Min. /Max. ambient temperature
- Min. /Max. liquid temperature
- Max. relative humidity (non-condensing)
- Max. altitude above sea level

4.2 Electrical data

- Electric stirrer for all tank sizes
– single-phase, 115/208-230 V, 60 Hz
- Electric stirrer for tanks of 15 gal (60 l) and 26 gal (100 l)
– single-phase, 220-240 V, 50/60 Hz
- Electric stirrer for tanks of 52 gal (200 l), 79 gal (300 l), 132 gal (500 l) and 264 gal (1000 l)
– single-phase, 230 V, 50 Hz
or
– single-phase, 240 V, 50 Hz
- For more details, refer to the installation and operating instructions for the electric stirrer and dosing pump.

4.3 Hydraulic data

4.3.1 Process connection

- with injection unit: 1/2" NPT
- without injection unit: see hydraulic connection of the dosing pump.

4.3.2 Suction line

Suction hose PE 1/4" x 3/8" (6/9 mm) (3/8" x 1/2" (9/12 mm) for DDI 60-10) with included connection for the suction side of the dosing pump.

4.4 Dimensions

Note: all dimensions are shown: inch (mm) unless otherwise noted.

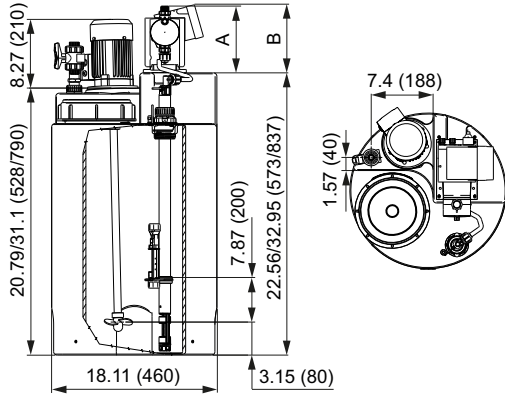

TM05 9506 3913

Fig. 1 Dosing tank station 15 / 26 gal (60 / 100 l)

Pump type	A* [in. (mm)]	B** [in. (mm)]
DDA 7.5-16, DDC 6-10, DDC 9-7	7.72 (196)	7.91 (200.8)
DDE 6-10	7.72 (196)	6.36 (161.5)
DDA 12-10, DDA 17-7, DDC 15-4	7.89 (200.5)	7.91 (200.8)
DDE 15-4	7.89 (200.5)	6.36 (161.5)
DDA 30-4	8.05 (204.5)	7.91 (200.8)
DMX 221, P _{max.} = 43 psi (3 bar)	7.76 (197)	12.56 (319)
DMX 221, P _{max.} = 58 psi (4 bar)	7.56 (192)	12.56 (319)
DMX 221, P _{max.} = 145 / 232 psi (10 / 16 bar)	7.05 (179)	12.56 (319)
DDI 60-10	9.92 (252)	9.06 (230)

* A: height of pump up to discharge connection

** B: height of pump housing or motor

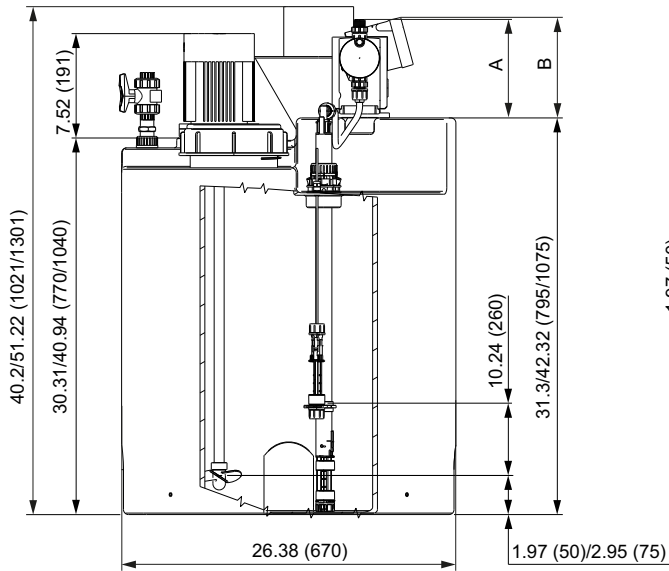

TM05 9507 3913

Fig. 2 Dosing tank station 52 / 79 gal (200 / 300 l)

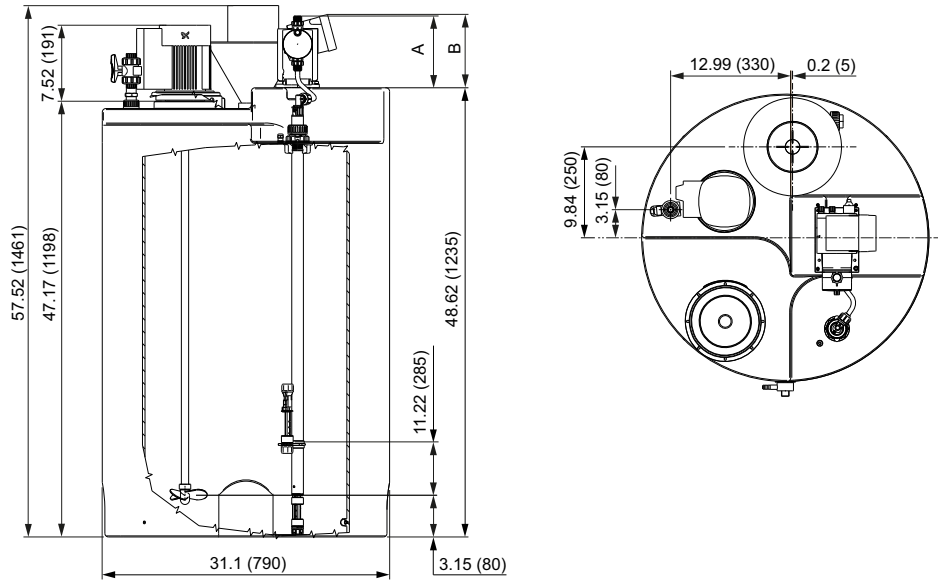

Fig. 3 Dosing tank station 132 gal (500 l)

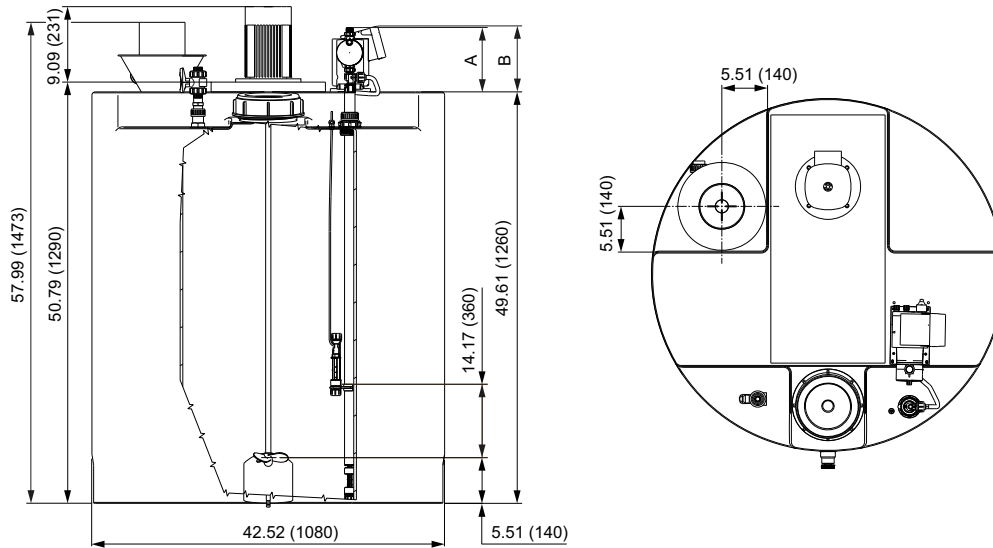

Fig. 4 Dosing tank station 264 gal (1000 l)

Note: all dimensions are shown: inch (mm) unless otherwise noted.

Pump type	A* [in. (mm)]	B** [in. (mm)]
DDA 7.5-16, DDC 6-10, DDC 9-7	7.72 (196)	7.91 (200.8)
DDE 6-10	7.72 (196)	6.36 (161.5)
DDA 12-10, DDA 17-7, DDC 15-4	7.89 (200.5)	7.91 (200.8)
DDE 15-4	7.89 (200.5)	6.36 (161.5)
DDA 30-4	8.05 (204.5)	7.91 (200.8)
DMX 221, p _{max.} = 43 psi (3 bar)	7.76 (197)	12.56 (319)
DMX 221, p _{max.} = 58 psi (4 bar)	7.56 (192)	12.56 (319)
DMX 221, p _{max.} = 145 / 232 psi (10 / 16 bar)	7.05 (179)	12.56 (319)
DDI 60-10	9.92 (252)	9.06 (230)

* A: height of pump up to discharge connection

** B: height of pump housing or motor

TM05 9508 3913

TM05 9509 3913

4.5 Materials in contact with media

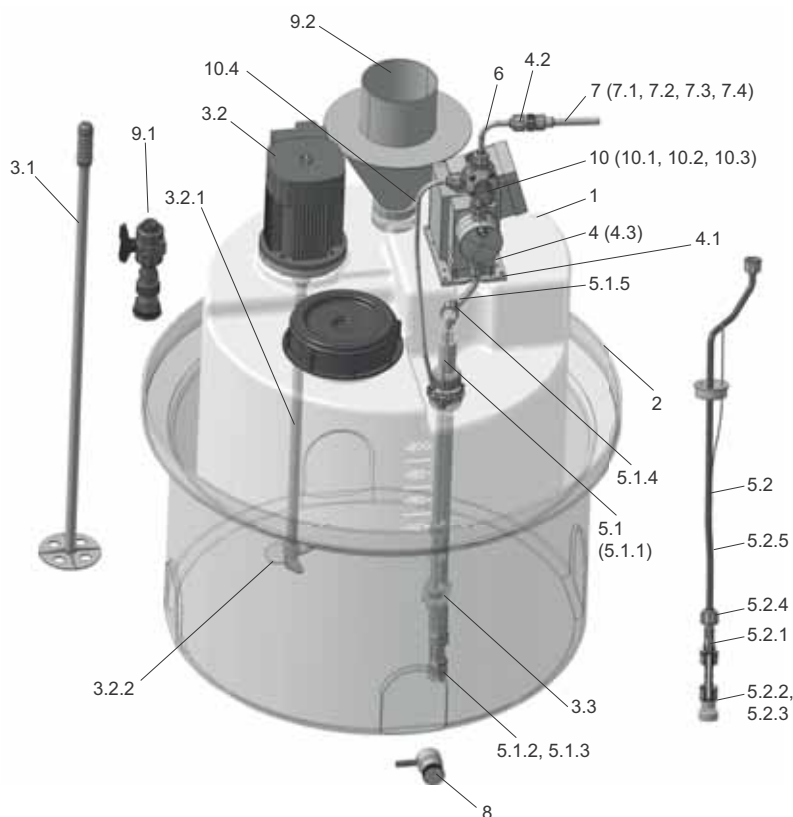

Fig. 5 Components that come into contact with media

Pos.	Description	Material
1	Dosing tank	PE
2	Collecting tray	PE
3	Mixer or stirrer	
3.1	Handheld mixer	PE
3.2	Electric stirrer	
3.2.1	Shaft	SS AISI 316Ti, PP
3.2.2	Propeller	PP
3.3	Level switch for electric stirrer	PE
4	Installation material	
4.1	Screws and washers	Tank sizes 15-132 gal (60-500 l): SS AISI 321 (screws), SS AISI 304 (washers); Tank size 264 gal (1000 l): PP
4.2	Connection kits (only DDI and DMX)	PP, PVC
4.3	Mounting plate (only DDA, DDC, DDE)	PPO/PS 20 % GF
5	Suction line	
5.1	Rigid suction lance with suction line	
5.1.1	Rigid suction lance	PE
5.1.2	Valve ball	Ceramic Al ₂ O ₃ 99.5 %
5.1.3	Valve seat	PTFE
5.1.4	Gasket	FKM, EPDM or PTFE
5.1.5	Suction line	PE
5.2	Flexible suction line with foot valve	

Pos.	Description	Material
5.2.1	Foot valve	PE
5.2.2	Valve ball	Ceramic Al ₂ O ₃ 99.5 %
5.2.3	Valve seat	PTFE
5.2.4	Gasket	FKM, EPDM or PTFE
5.2.5	Suction line	PE
6	Discharge line	PE
7	Injection unit	
7.1	Body	PVC or PP
7.2	Gaskets	FKM, EPDM or PTFE
7.3	Spring	Tantal
7.4	Ball	Ceramic Al ₂ O ₃ 99.5 %
8	Drain valve	PVC/EPDM
9	Filling device	
9.1	Filling armature	PVC/EPDM
9.2	Dissolving hopper	PVC/EPDM
10	Multi-function valve	
10.1	Body	PVDF
10.2	Gaskets	FKM, EPDM or PTFE
10.3	Diaphragm	PTFE
10.4	Relief line	PE

Note

For more details, refer to the installation and operating instructions of the components.

TM05 9321 3713

5. Structure and function

5.1 Product overview

DTS dosing tank stations can comprise the following modules (selection depending on model key):

- Chemically resistant tank
 - UV-stabilized semi-transparent or black PE
 - 6 sizes between 15 and 264 gallons (60 and 1000 liters)
 - threaded M 6 inserts and/or adapter plate for installing a dosing pump
 - embossed liter scale
 - screw cover, PE
- Collecting tray, PE, in various sizes for dosing tanks of 15 to 264 gallons (60 to 1000 liters)
- Handheld mixer or electric stirrer with level switch
- Flexible or rigid suction line, PE, with foot valve and 2-step level switch for idling protection
- Injection unit, PVC or PP, with 1/2" NPT screw-in thread
- 33 ft (10 m) discharge line, PE
- Drain valve
- Filling device
- Multi-function valve

The components for the discharge side of the pump are prepared for subsequent installation and enclosed with the delivery packaged separately.

5.1.1 Dosing pump

Depending on the application requirements, the dosing pump can be selected from the following series and ordered separately.

- DDA, DDE, DDC up to 7.93 gph (30 l/h)
- DMX 221 up to 13.21 gph (50 l/h)
- DDI 60-10

5.1.2 Components of a DTS dosing tank station

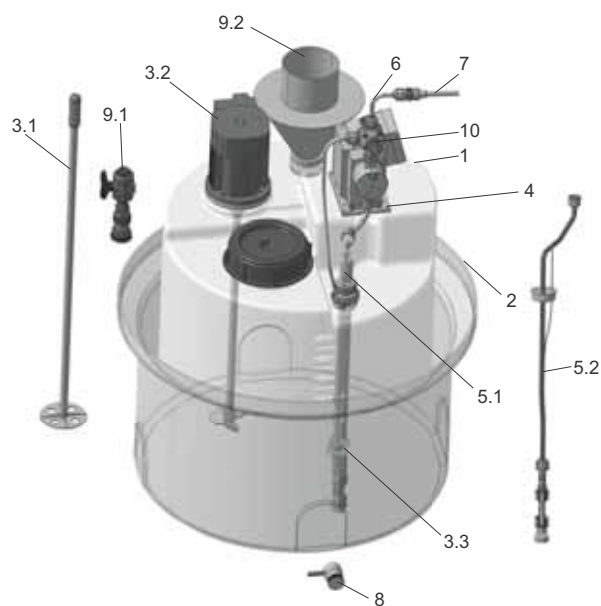

TM05 9322 3713

Fig. 6 DTS dosing tank station (example)

Pos.	Description
1	Dosing tank
2	Collecting tray
3	Mixer or stirrer
3.1	Handheld mixer
3.2	Electric stirrer
3.3	Level switch for electric stirrer
4	Installation material
5	Suction line
5.1	Rigid suction lance
5.2	Flexible suction line with foot valve
6	Discharge line
7	Injection unit
8	Drain valve
9	Filling device
9.1	Filling armature with ball valve
9.2	Dissolving hopper
10	Multi-function valve

6. Commissioning

6.1 Transport and storage

Caution Do not throw or drop the DTS dosing tank station. Only transport the DTS dosing tank station, if the dosing pump is disassembled.

6.1.1 Unpacking

- Check the DTS dosing tank station for visible transport damage immediately after receipt.
- Dispose of the packaging in accordance with local regulations.

6.2 Installation

Note The DTS dosing tank station may contain water from the check carried out in the factory.

Some media react with water.

Caution If you dose a medium that reacts with water, remove the water from the DTS dosing tank station first.

6.2.1 Installation site

The installation site must be horizontal, even, frost-free and suitable for the corresponding loads.

The DTS dosing tank station must be easily accessible.

Avoid direct sunlight. The materials of the DTS dosing tank station may be damaged by sunlight.

When installing the DTS dosing tank station outdoors, provide protection from rain and weathering.

Caution Before starting work, check if all technical conditions required at the installation site comply with the data on the nameplate of the DTS dosing tank station.

6.2.2 Hydraulic connection

Depending on the scope of supply, the customer must install the components.

Refer to the installation and operating instructions for the components used.



Warning

The dosing medium is pressurized and can be harmful. Observe the maximum permissible pressure.

When working with chemicals, apply the accident prevention regulations at the installation site and the technical rules for working with chemicals (e.g. wearing of protective clothing).

Warning

Before working on the dosing pump and system, mains cables must be disconnected and secured to prevent them being switched on again. Before switching the supply voltage back on, the dosing lines must be connected such that any chemicals in the dosing system cannot spray out and put people at risk.



Warning

Overflowing dosing medium must always be returned to a tank.



- Media such as peracetic acid and hydrogen peroxide must be returned to a separate tank.
- Other media can be returned to the dosing tank.

The overflow hose provided with the multi-function valve must be connected and routed to the corresponding tank or the cap of the suction lance or foot valve.

Warning



When changing chemicals, check the chemical resistance of the materials used. If there is a risk of a chemical reaction between the chemicals, clean the DTS dosing tank station thoroughly before dosing the new chemical.

6.2.3 Installation of the dosing pump

Note The installation material for the dosing pump (screws, nuts, washers) is delivered with DTS dosing tank stations that have the "Preparation for dosing pump" option.

- Mount the dosing pump with the suitable installation material directly on the dosing tank or adapter plate.

Refer to the installation and operating instructions for the dosing pump.

6.2.4 Installation of the multi-function valve

- Fit the multi-function valve directly on the pressure valve of the dosing pump.

Refer to the installation and operating instructions for the multi-function valve.

6.2.5 Installation of the dosing lines

Route hoses free from mechanical tension and bends.

Caution Only use the clamp rings and hose connectors intended for the hose diameter in question.

Only use original hoses with the required dimensions and wall thickness.

Observe the maximum permissible operating pressure.

Connect the suction line to the suction valve of the dosing pump. Connect the discharge line to the discharge valve or to the multi-function valve of the dosing pump.

1. Cut the hose ends to length (straight cut).
2. Pull the union nut and the clamp ring over the hose.
3. Slide the hose end over the connector until the stop, widen if necessary. Depending on the type of connection, secure it with a counterpiece or a hose clip.
4. Fit gasket.
 - Ensure that the O-ring or flat gasket is positioned correctly in the counterpiece (pump valve/injection unit).
5. Use the union nut to screw the hose on the valve.

Refer to the installation and operating instructions for the dosing pump.

6.2.6 Installation of the injection unit

- Screw the injection unit into the coupling thread (provided by the customer) of the process line vertically from above.

Refer to the installation and operating instructions for the injection unit.

6.3 Tightness check

- Before filling the dosing tank, check that the following requirements are fulfilled:
 - the suction lance is connected
 - the optional drain valve is fully closed
- Only with drain valve: Fill the dosing tank with water and check for leaks.

Some media react with water.

Caution

If you dose a medium that reacts with water, use a suitable other medium for the tightness check.

6.4 Electrical connection



Warning

Electrical connections must be established by trained personnel.

Observe the local safety regulations.

Protect the cable connections and plugs against corrosion and humidity.

Before connecting the mains cables, check whether the supply voltage stated on the nameplates of the dosing pump and electric stirrer matches the local figures (permissible mains frequency deviation: $\pm 5\%$). An incorrect mains voltage may destroy the components.

Caution

- Fuse the motor with a motor overload switch of the appropriate rating.

6.4.1 Electrical connection of the dosing pump

Refer to the installation and operating instructions for the dosing pump.

6.4.2 Electrical connection of the electric stirrer

Refer to the installation and operating instructions for the electric stirrer.

6.4.3 Electrical connection of the level switch

The suction unit and the electric stirrer are each fitted with a level switch.

- Plug the connector of the level switch of the suction line into the corresponding connector of the dosing pump.

The separate level control of the electric stirrer can be used via an external control unit to deactivate the electric stirrer when the tank is running empty.

6.4.4 Inputs and outputs

Refer to the installation and operating instructions for the dosing pump and the suction line.

7. Operation

The dosing tank is not operated. Within the system, it simply serves as a reservoir for storage and dosing of the medium.

Caution

All the system components must be ready for operation.

Follow the installation and operating instructions for the components and the dosing pump used.



Warning

Never reach into the dosing tank when the electric stirrer is running.

The rotating propeller and mixing shaft may result in serious injuries.

Before switching on the electric stirrer, fill the dosing tank with dosing medium to at least 7.9 in (20 cm) above the propeller.

Caution

If this is not done, turbulence may occur when stirring and the mixing shaft may be damaged.

The point at the top of suction unit where the suction line and level cable emerge must not be blocked or sealed.

Caution

Air must enter there, in order to compensate for pressure in the dosing tank.

8. Maintenance

The dosing tank requires no maintenance.

Caution

Observe the installation and operating instructions for the components used.

8.1 Cleaning

Clean the dosing tank and components, if necessary.



Warning

When dosing dangerous media, observe the corresponding safety precautions.

Wear protective clothing (gloves and goggles).

8.2 Service



Warning

All service work must be carried out by authorized and qualified personnel.

Should a fault arise please provide an accurate description of the problem.

Please refer to the nameplate for the technical data.

9. Accessories, spare parts

Replace faulty accessories by new ones. Information on accessories is available on www.grundfos.com or in the data booklets:

- Accessories for dosing pumps
- SMART Digital, DDA, DDC, DDE, Pumps and accessories

10. Disposal

This product or parts of it must be disposed of in an environmentally sound way. Use appropriate waste collection services. If this is not possible, contact the nearest Grundfos company or service workshop.

11. Appendix

11.1 Documentation enclosed

The DTS dosing tank station is supplied together with the DTS installation and operating instructions.

Depending on the scope of supply, separate installation and operating instructions are provided for the following components:

- electric stirrer
- suction line (suction unit) (quick guide)
- multi-function valve

11.2 Other documentation

Separate installation and operating instructions are available on the CD supplied or on www.grundfos.com for the following components:

- injection unit
- suction line (suction unit)

Subject to alterations.

GRUNDFOS Kansas City

17100 West 118th Terrace
Olathe, Kansas 66061
Phone: (913) 227-3400
Fax: (913) 227-3500

www.grundfos.us

GRUNDFOS Canada

2941 Brighton Road
Oakville, Ontario L6H 6C9 Canada
Phone: +1-905 829 9533
Telefax: +1-905 829 9512

www.grundfos.ca

GRUNDFOS México

Boulevard TLC No. 15
Parque Industrial Stiva Aeropuerto
C.P. 66600 Apodaca, N.L. México
Phone: 011-52-81-8144 4000
Fax: 011-52-81-8144 4010

www.grundfos.mx

98564086 0414
ECM: 1134526

The name Grundfos, the Grundfos logo, and be think innovate are registered trademarks owned by Grundfos Holding A/S or Grundfos A/S, Denmark. All rights reserved worldwide. © Copyright Grundfos Holding A/S