

Grundfos CR Cool-Top®

High liquid temperatures require special measures

Where pumping of very hot liquids is required, pumps must be equipped to handle these temperatures — but unfortunately no shaft seal can tolerate very hot liquid temperatures. Production can be brought to an unexpected standstill due to shaft seal failure. Grundfos has designed the Cool-Top — a CR

pump with a standard mechanical shaft seal that can handle liquid temperatures of up to 356°F (180°C) and at the same time deliver high pressures. The Grundfos CR Cool-Top has an air-cooled chamber that separates the pumped liquid from the shaft seal and protects it from overheating.



Grundfos CR Cool-Top® advantages

Air-cooled Top

The Grundfos CR Cool-Top pump is specially designed to handle liquids from 248°F to 356°F (120°C to 180°C). To ensure the liquid temperature around the shaft seal does not exceed the level it can withstand, the pump is fitted with a special air-cooled shaft seal chamber generating the same insulation effect as a thermos. No external cooling is necessary to cool the pump; the ambient temperature is sufficient.

Long lifespan of shaft seal

The lifespan and efficiency of a shaft seal depends on the nature of the pumped liquid and its temperature. Because of the CR Cool-Top pump's unique construction, the pump is able to withstand high temperatures over a long period of time. The pump is available with different rubber qualities specially designed to provide long life under extreme operating conditions.

Technical data	
Max. pressure	580 psi (40 bar)
Liquid temp.	32°F to 356°F (0°C to 180°C)
Max. ambient temp.	104°F (40°C)
Liquids	Any liquids handled by Grundfos CR pumps
Min. inlet pressure	No change from standard CR
Min. flow	No change from standard CR

Custom-built solutions

Grundfos CR range covers a wide range of industrial applications. Grundfos also designs custom-built pump solutions. We can provide a custom-built Grundfos CR capable of handling even higher pressures, more aggressive liquids, excessive liquid temperatures etc. than our standard CR pumps.



Sectional drawing

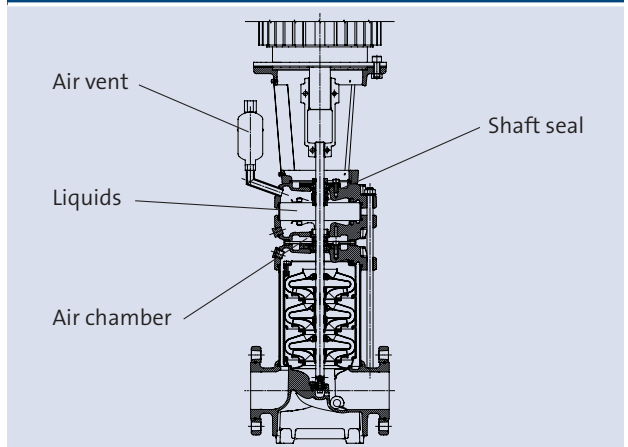

Worldwide pump supplier

Being a worldwide pump supplier, Grundfos has committed itself to provide its clients with a global, reliable and efficient service network. Our experienced team of technicians are ready to provide service wherever in the world you are, whenever you need it.

L-CR-SL-014	Rev. 1/04
PRINTED IN USA	

Subject to alterations