



6210-C

SOFT SERVE FREEZER

Single Flavor, Countertop, Digital Control

Most **Compact & Versatile** single flavor countertop model for soft serve ice cream and frozen yogurt

Fast Freeze Down

Patented high efficiency heat exchanger allows fast freeze down with low energy consumption

Digital Control and Display

Digital control provides access to system settings and displays critical system information

Auto Programming

Allows automatic switching of operation modes based on preset schedules

Standby

Maintains product temperature in both mix hopper and freezing cylinder below 4.4°C (40°F) overnight

Ideal for any business with limited counter space to add ice cream, frozen yogurt, gelato or sorbet. Flexible with digital control and display. Great fit for restaurants, bars, kitchens, convenience stores and delis.



Defrost for Cleaning

Increases efficiency during cleaning by heating frozen product in cylinder

Quick Freeze

Turn on freeze immediately to freeze down to serving viscosity when quick service is required after long idle period

Self-closing Valve with Speed Control

Automatically prevents product overflow after dispense; Provides flexibility in dispense rate control

Safety Protections

- Low temperature and motor overload shutoffs to protect in the event of cylinder freeze up
- High pressure switch to prevent compressor overheating



6210-C

SOFT SERVE FREEZER

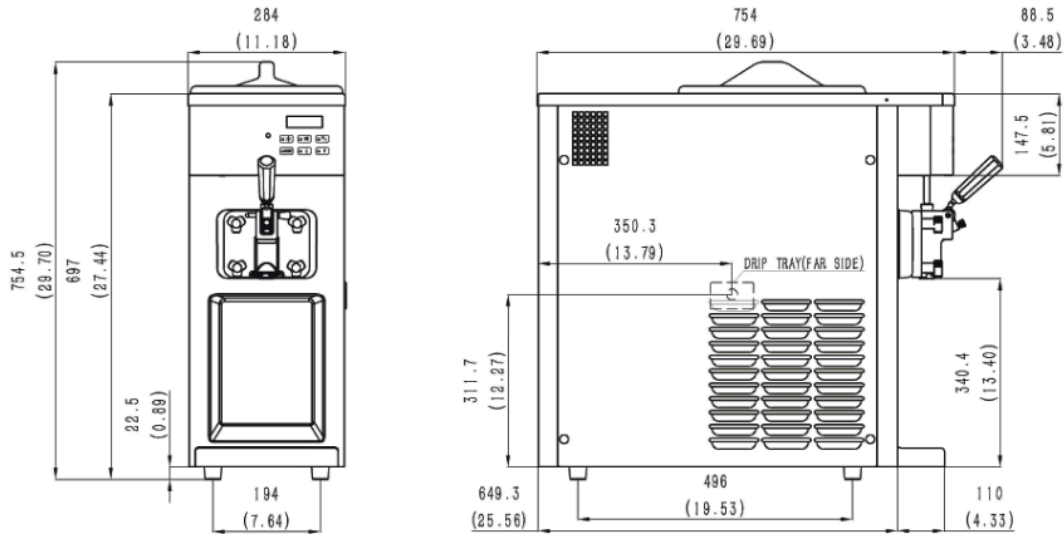

SPECIFICATIONS

Flavors	1
Freezing Cylinders	1 x 1.2L / 1.3qt
Mix Hoppers	1 x 8L (5L for A)
Output Capacity (80 grams)	150 serves/hr
Clearance Requirements	150mm/6" on back

Weight Kg/lb

Net	90 / 198
Shipping	102 / 225
Volume	0.27 CBM / 9.53 CBF

Dimensions Net (mm/in) Shipping (mm/in)

Width	284 / 11.2	380 / 15.0
Depth	693 / 25.6	800 / 31.5
Height	755 / 29.7	900 / 35.4

Electrical MFS MCA Power(kW)

110-115/60/1	20	16	1.6
--------------	----	----	-----

FEATURES

Control System	Single, Digital
Refrigerated Hopper	<input checked="" type="checkbox"/>
Temperature Display	<input checked="" type="checkbox"/>
Standby Mode	<input checked="" type="checkbox"/>
Auto Closing Dispensing Valve	<input checked="" type="checkbox"/>
Dispensing Speed Control	<input checked="" type="checkbox"/>
Low Mix Indicator Light & Alarm	<input checked="" type="checkbox"/>
Low Temperature Protection	<input checked="" type="checkbox"/>
Motor Overload Protection	<input checked="" type="checkbox"/>
High Pressure Protection	<input checked="" type="checkbox"/>
Defrost & Quick Freeze	<input checked="" type="checkbox"/>

AVAILABLE OPTIONS

Cart (Trolley)	<input checked="" type="checkbox"/>
----------------	-------------------------------------

• Above specifications are subject to change without notice